

MICROWAVE OVEN

SERVICE MANUAL

MODEL : MA-2005ST

CAUTION

BEFORE SERVICING THE UNIT, READ THE
SAFETY PRECAUTIONS IN THIS MANUAL.

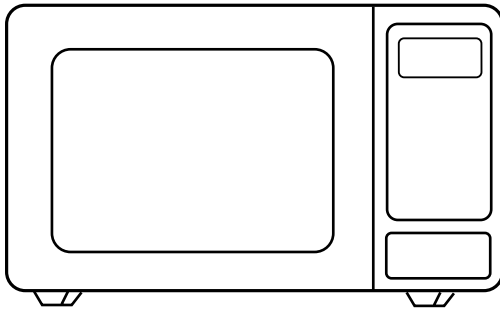

SAFETY PRECAUTIONS

This device is to be serviced only by properly qualified service personnel.

Consult the service manual for proper service procedures to assure continued safety operation and for precautions to be taken to avoid possible exposure to excessive microwave energy.

PRECAUTIONS TO BE OBSERVED BEFORE AND DURING SERVICING TO AVOID POSSIBLE EXPOSURE TO EXCESSIVE MICROWAVE ENERGY

- A) Do not operate or allow the oven to be operated with the door open.
- B) Make the following safety checks on all ovens to be serviced before activating the magnetron or other microwave source, and make repairs as necessary; (1) interlock operation, (2) proper door closing, (3) seal and sealing surfaces (arcing, wear, and other damage), (4) damage to or loosening of hinges and latches, (5) evidence of dropping or abuse.
- C) Before turning on microwave power for any service test or inspection within the microwave generating compartments, check the magnetron, wave guide or transmission line, and cavity for proper alignment, integrity, and connections.
- D) Any defective or misadjusted components in the interlock, monitor, door seal, and microwave generation and transmission systems shall be repaired, replaced, or adjusted by procedures described in this manual before the oven is released to the owner.
- E) A microwave leakage check should be performed on each oven prior to release to the owner.

CAUTION MICROWAVE RADIATION

DO NOT BECOME EXPOSED TO RADIATION FROM THE MICROWAVE GENERATOR OR OTHER PARTS CONDUCTING MICROWAVE ENERGY.

2-1. Function & Type (1/2)

1. How a Microwave Oven Works

The microwave oven is one of the great inventions of the 20th century - millions of homes in world have one. Microwave ovens are popular because they cook food incredibly quickly. They are also extremely efficient in their use of electricity because a microwave oven heats only the food - nothing else.

A microwave oven uses microwaves to heat food. Microwaves are radio waves. In the case of microwave ovens, the commonly used radio wave frequency is roughly 2,500 megahertz (2.5 gigahertz). Radio waves in this frequency range have an interesting property: they are absorbed by water, fats and sugars. When they are absorbed they are converted directly into atomic motion - heat. Microwaves in this frequency range have another interesting property: they are not absorbed by most plastics, glass or ceramics. Metal reflects microwaves, which is why metal pans do not work well in a microwave oven.

2. Type of Microwave Oven

1) MICROWAVE COOKING (solo model)

Using the energy of microwaves only, food is cooked quickly without altering its colour and shape. Microwaves generated by a magnetron enter the oven and cook the food evenly on a rotating turntable. Power control can be adjusted in 11 steps which can enable a variety of goods to cook at a suitable power for the best results.

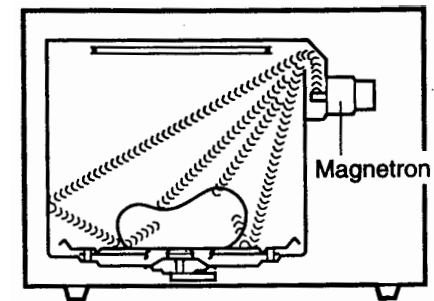

2-1. Function & Type (2/2)

2) GRILL COOKING

This is a method of cooking with radiant heat from the grill heater on the top of the oven. This is a traditional way of cooking which quickly seals and browns food evenly. The temperature inside the oven is fixed at 180°C, which is ideal grilling temperature for this oven.

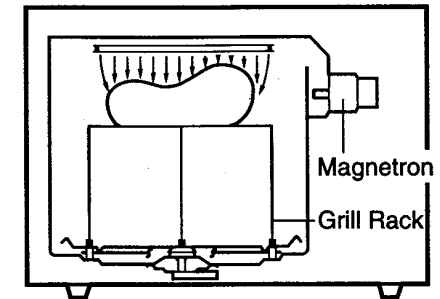

3) CONVECTION COOKING

This is a method of cooking with hot air from the convection heater situated at the rear of the oven. This method allows food to be browned evenly without losing any of the juices. Air heated by the heater is circulated in the oven by a fan. This enables the efficient heating and cooking of food. The temperature inside the oven can be controlled according to the type and weight of food being cooked.

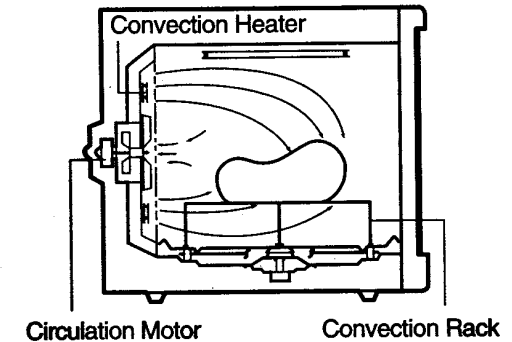

4) COMBINATION COOKING

Using a combination of microwaves, hot air and radiant heat, this solid state control can cook alternately, according to the cycles programmed. This efficient method of cooking fully utilizes the advantages of all three functions, giving quick results with a traditional appearance to your cooking.

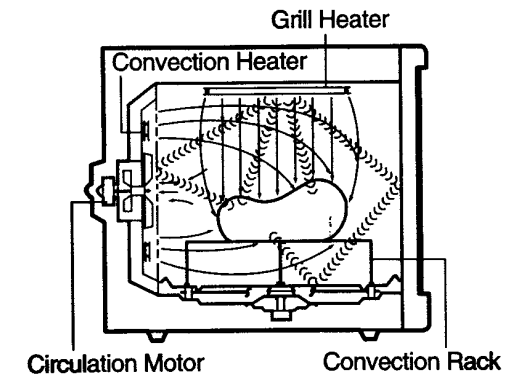

2-2. Installation & Utensils (1/2)

1. Installation

1. Unpack your oven and place it on a flat level surface.
2. Place your oven in the level location of your choice with more than 85cm height but make sure there is at least 30cm of space on the top and 10cm at the rear for proper ventilation. The front of the oven should be at least 8cm from edge of the surface to prevent tipping. An exhaust outlet is located on top of side of the oven. Blocking the outlet can damage your oven.

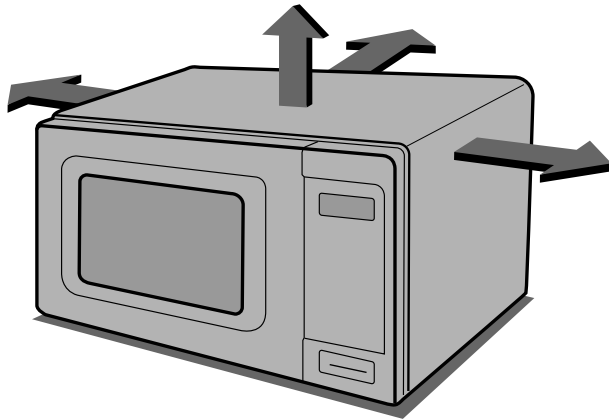

3. Plug your oven into a standard household socket. Make sure your oven is the only appliance connected to the socket. **If your oven does not operate properly, unplug it from the electrical socket and then plug it back in.**
4. Open your oven door by pressing the **DOOR HANDLE**. Place the **ROLLER REST** inside the oven and place the **GLASS TRAY** on top.

5. Fill a **microwave safe container** with 300 ml (1/2 pint) of water. Place on the **GLASS TRAY** and close the oven door.



6. Press the **START** button six times to set 3 minutes of cooking time. You will hear a BEEP each time you press the button. Your oven will start before you have finished the sixth press; don't worry this is normal.



7. The **DISPLAY** will count down from 3 minutes. When it reaches 0 it will sound three BEEPS. Open the oven door and test the temperature of the water. If your oven is operating the water should be warm. **Be careful when removing the container it may be hot.**



2-2. Installation & Utensils (2/2)

2. COOKING UTENSILS

Utensils should be checked to ensure that they are suitable for use in the microwave oven.

The following chart summarizes the proper use of cooking utensils in your oven:

Cooking utensils	Microwave	Grill
Heat resistant glass, glass ceramic	yes	yes
Ceramic, china	yes (Do not use china with gold or silver trim.)	yes
Metal cookware	no	yes
Non-heat resistant glass	no	no
Microwave plastic	yes	no
Plastic wrap	yes	no
Paper (cup, plates, towels)	yes	no
Straw, wicker and wood	no	no

Microwave

1. Most glass, glass ceramic, and heat resistant glassware utensils are excellent. Those with metal trim should not be used in a microwave oven.
2. Paper napkins, towels, plates, cups, cartons, and cardboard can be used in the microwave oven. Do not use recycled paper products since they may contain impurities which may cause sparks and/or fires when used in cooking. (Consult your cookbook for correct use of these products.)

3. Plastic dishes, cups, freezer bags, and plastic wraps may be used in the microwave oven. Follow the manufacturer's instructions or the information given in the cookbook when using plastics in the microwave oven.
4. Metal utensils and utensils with metallic trim should not be used in the microwave oven. For more information on the proper use of metal in your oven, please read the introduction section in the cookbook. If the use of aluminum foil, skewers, or utensils containing metal in the oven is specified in the recipe, allow at least 2.5cm clearance between the metal object and the interior oven wall. If arcing (sparks) occurs, remove immediately.

Note:

Consult your cookbook, individual recipes, and charts for correct use of cooking containers, products, and other useful information.

Grill

1. Heat resistant glassware, ceramic and metal cookware can be used.
2. Paper napkins, towels, and plastics should not be used.

Note:

- Care should be taken when removing utensils or the glass turntable, as they may become hot during cooking.
- Only use a thermometer that is designed or recommended for use in the microwave oven.
- Ensure the turntable is in place when you operate the oven.

3-1. What's the microwave? (1/2)

1. History of dielectric heating

In 1945, Dr. Spencer working for RAYTHEON Co. in the U.S.A found out a pieces of chocolate in his pocket melting suddenly by the electric wave (ultra high frequency wave using for radar) on his experiment for radar. then began research in heating matters by the electric wave.

So far, experiments for heating foods by the electric wave has been developed into the household telephone as well as microwave oven, etc. The heating method for microwave is to give an electric wave to the food and make the food itself generate heat. It is different from that of the past which was to give heat to the food and make the temperature rise.

So, since the microwave oven does not give any heat to the food, we do not need appliances like the gas oven.

Not only the microwave oven itself but utensil don't get hot either, when heat is provided, the utensil will gradually got hot by thermal conduction, however, the temperature of the surface and the inside of the fond get hot simultaneously and the food is well-done rapidly.

2. The principle of dielectric heating

The microwave oven has a vacuum tube called magnetron (M.G.T), it injects the electric wave of 2450MHz (The vibrations of two billion four hundred and fifty million per second are given to the oven) This electric wave is called the microwave. The wireless electric wave (having not more than 1 m of the wave length) is using for the radio telephone and broad casting of T.V. and radar (a radio locator). It is similar to an electric wave and its wave length is short. (The length of the electric wave having frequency of 2450MHz is 12.2cm)

The characteristics of this microwave is as follows:

1. When it touches the metal, it is reflected and changed direction.
2. It passes through ceramics, porcelain (glass, etc), plastics, and paper.
3. If it is touches the food or the wood having water in humidity, it is absorbed and generates heat.

The Microwave oven cook food using these characteristics. Generally, the food, whether it is large or small has humidity. So if you put this food in the microwave oven and it gets the electric wave, so the energy of it is absorbed in the food since it set up a vibration of the molecules with a frequency two billion four hundred and fifty million times per second. The friction among molecules of food occurs repeatedly. It then causes the frictional heat, and the temperature of the food rises.

3-1. What's the microwave? (2/2)

3. The safety of microwave oven

Since the microwave oven can't make the native fire like gas, you have no use for worrying about the fire.

Because it doesn't become hot like the ordinary electric range. It has been used in the dinner car of the trains etc.

Microwave oven has the shielded structure strictly with metal case not to leak electric wave at once not only using but on opening the door.

Because it uses the electric wave, the x-ray is never emitted. The UHF wave generally called microwave is like the electric wave of the TV or the radio and is used for the wireless communication, the radar and the UHF medical instruments (using 2450 MHz like that of the microwave oven, etc).

4. Definition of electric wave

* An electric wave is the electron wave of the frequency from 10 KHz to 3,000,000 MHz.

* Wave length of 2450 MHz.

$$\lambda = \frac{c}{f} = \frac{300000 \text{ Km}}{245000 \text{ KHz}} \doteq 0.122 \text{ m} \doteq 12.2 \text{ cm}$$

λ : Wave Length

Where c: The Velocity of Light

f: Frequency

The division from the sound frequency to the light frequency.

FREQ	20 Hz 20 KHz	3 Hz 30 KHz	30 Hz 300 KHz	300 KHz 3 MHz	3 MHz 30 MHz	30 MHz 300 MHz	300 MHz 3 GHz	3 GHz 30 GHz	30 GHz 300 GHz	300 GHz 10 ¹⁶ Hz
NAME	SOUND WAVE	VLF	LF	MF	HF	VHF	ULF	SHF	EHF	LIGHT
USE	MUSIC	SHIP	RADIO	RADIO	RADIO	T.V	MWO T.V	RADAR	RADAR	

3-2. Conventional heating vs. dielectric heating

1. Conventional heating

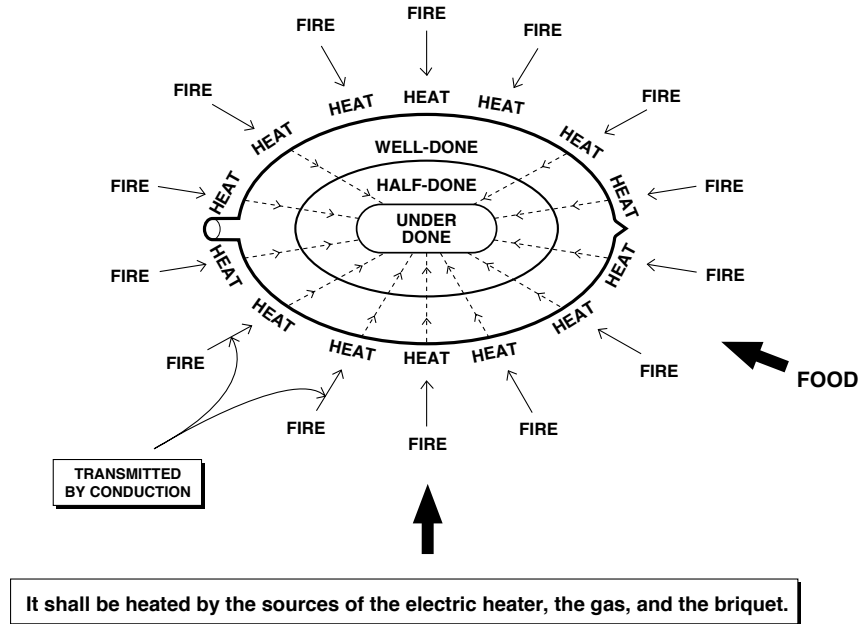

- * The heat energy from the sources of the heating power shall be transmitted from the warm surface to the cold inside.
- * Heating with the strong fire: The surface of the food shall be well done, but be burnt to have a black side, and the center of the food shall not be well-done.
- * Heating with the weak fire: The surface of the food shall be burnt and have a little black side, but it shall be taken lots of time for the center to be well-done.
- * The thermal conductivity in the water or in the food is low.

2. Dielectric heating

- 1) The heating is uniform.
- 2) The temperature rise is fast (high).
- 3) If you break the electric power: The microwave oven stops heating at once, so you can't heat something with the heat of their surroundings.
- 4) Since it heats inside, the surface isn't damaged.

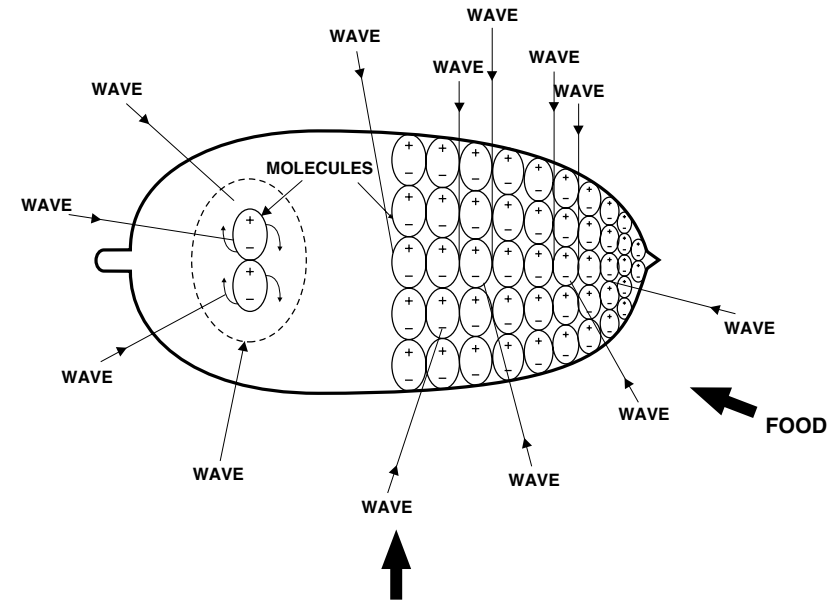

• If you give microwave to food with the microwave oven, the food and □
 □□ molecules of the water included in the food is turned, or moved and generates □
 □□ heat with the friction among the the molecules.

- * The water, the oil and the foods shall absorb the electric wave well.
- * It generates heat all around the apparatus and the foods are well-done with short time
- * If you heat something for long time, all of it will be burnt and can't be eaten.

4-1. Construction of microwave oven

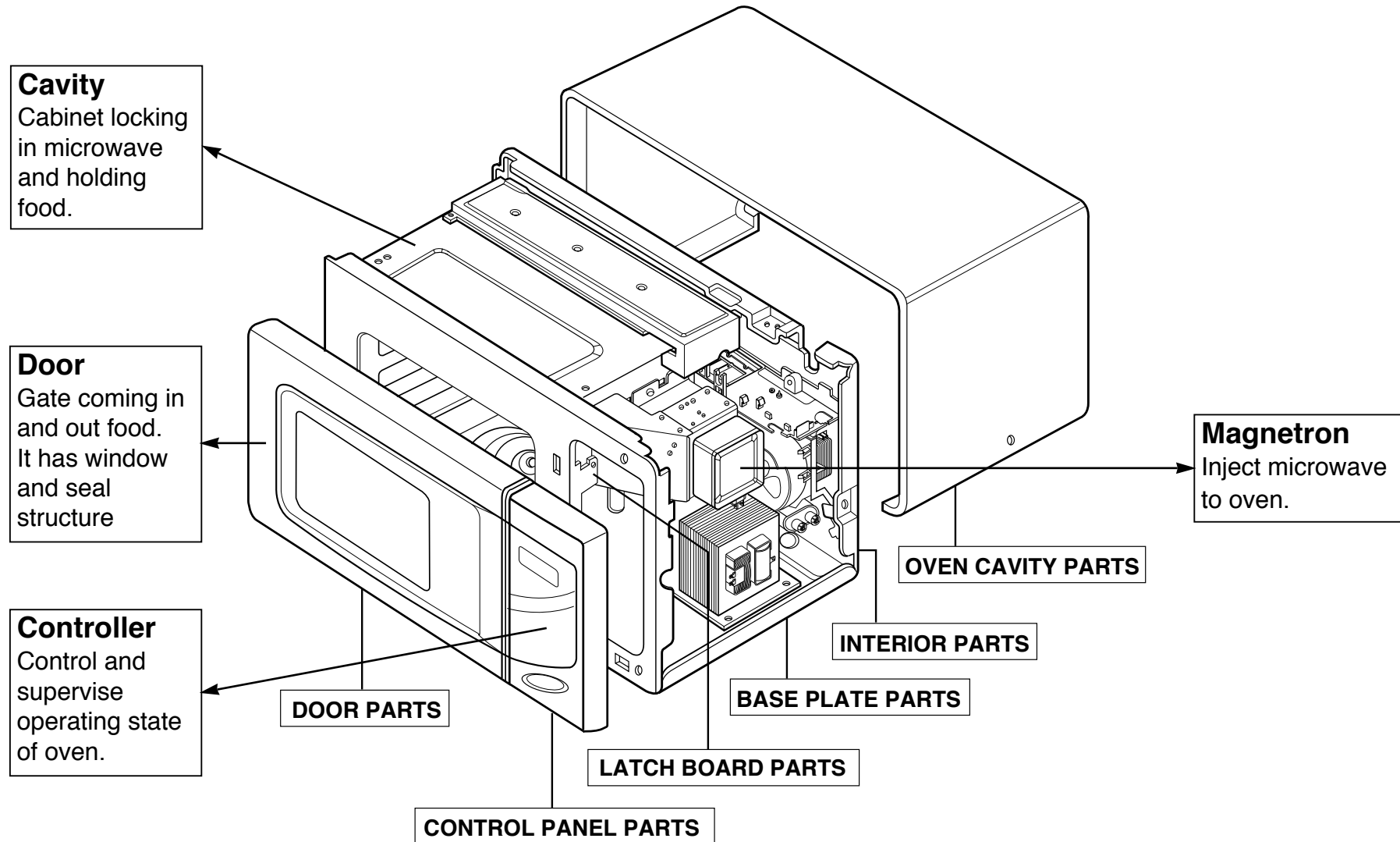

4-2. How does the microwave oven operate?

After plugging your oven into a standard household socket, press start button or turn the timer. And then switches (primary, secondary, timer) close the circuit. Eventually the input power will be applied to turntable motor, timer motor, fan motor, oven lamp and high voltage transformer. A high voltage of 2,100 volts AC is generated in the second winding of H.V. Transformer. And the voltage is doubled by H.V. Capacitor & H.V. Diode. The 4Kv DC voltage is applied to filament of magnetron, then magnetron start to produce microwave. This microwave is injected to cavity.

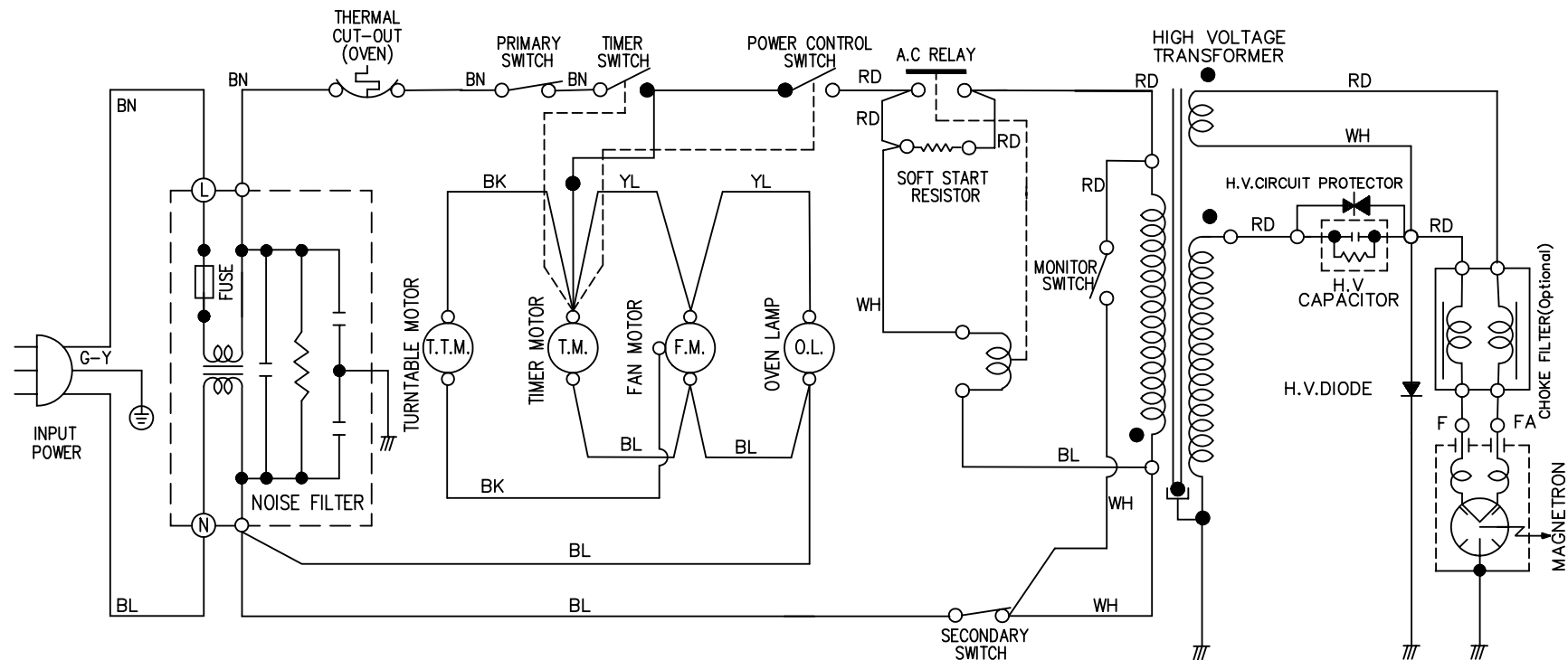

4-3. WARNING - High voltage circuit (4,000 volt)

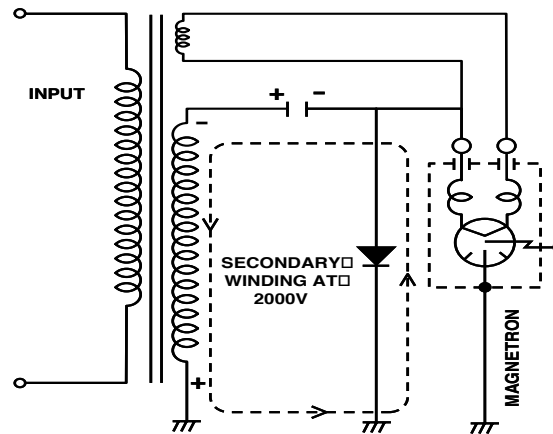
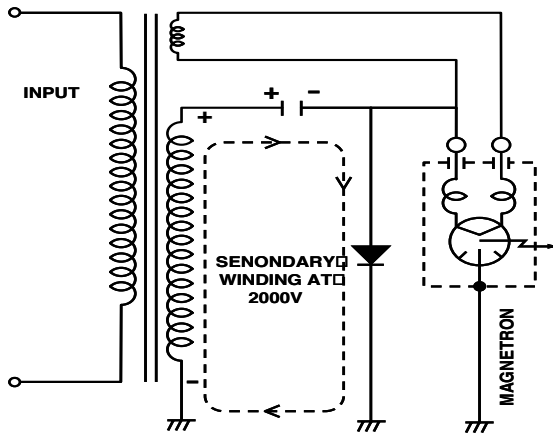

* The half-wave voltage doubler circuit consists of the secondary winding of the high voltage transformer, H.V. diode (rectifier), and H.V. capacitor. The H.V. diode allows alternating current (AC) to flow in one direction only and rectifies it to pulsating direct current (DC). The H.V. capacitor is able to store energy on one half of the AC cycle and release it on the other half cycle.

* During the first half cycle of operation, the secondary winding of the transformer supplies 2000 Volts to the capacitor current flows through the diode and returns to the transformer for a complete circuit. This half-cycle of AC charges the capacitor to approximately 2000 Volts.

* During the second half cycle of operation, the current flows in the opposite direction, again supplies 2000 Volts to the circuit.

* This permits the capacitor to discharge its 2000 Volts on top of the 2000 Volts generated by the secondary winding, creating an approximate total voltage of negative 4000 Volts D.C.

The negative 4000 Volts DC causes the magnetron to conduct current and, to oscillate at 2450 MHz.

The first half cycle and the second half cycle become one complete cycle, repeated input power frequency times per second .

4-4. Microwave generation system_Magnetron (1/2)

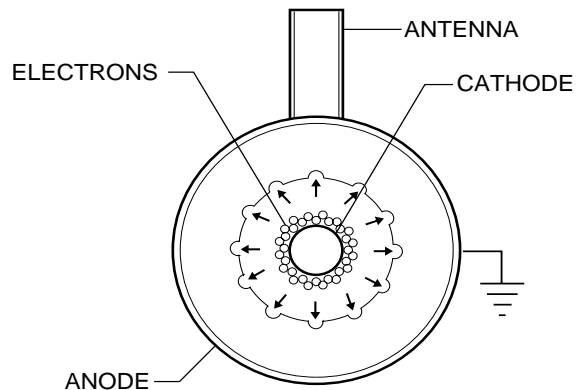
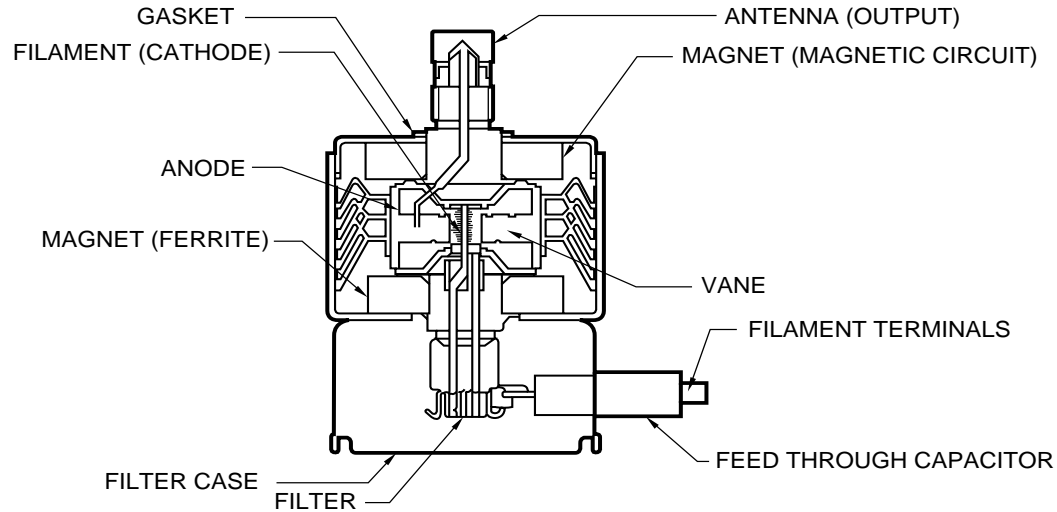

- * The magnetron is the energy source for the microwave oven. The magnetron is a vacuum tube of special construction. It is basically a diode with addition of a magnetic field. It consists of a small, coiled heating element (filament) made of tungsten which readily emits electrons when heated. This element serves as the cathode (negative element) within the tube. The anode (positive element of the tube) consists of a thick walled copper cylinder with vertical vanes extending inward which surround but do not touch the cathode. To complete the magnetron, and make it operate distinctly different from other vacuum tubes, two permanent magnets are mounted over each end of the tube.

4-4. Microwave generation system_Magnetron (2/2)

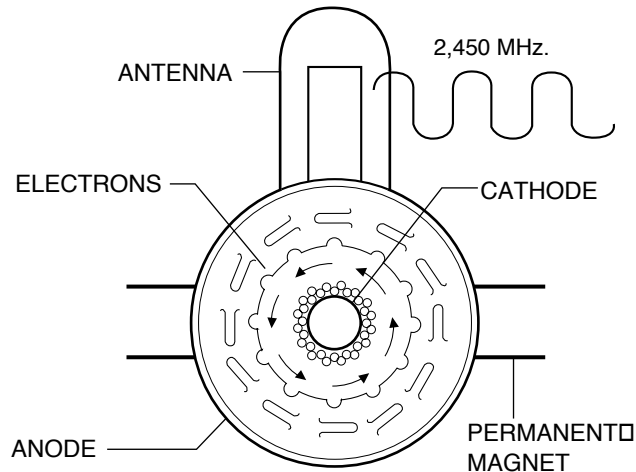

- * In order to create an electron flow from cathode to anode, the cathode must be heated and a potential difference must exist between the two. This is accomplished by heating the cathode with 3, 4 to 3,5 V AC. (from the filament winding of the high voltage transformer) and applying a negative 4000 V DC (from the voltage doubler circuit) to the cathode.
- * Originally the electrons would travel in a straight line from the cathode to the anode. However, with the addition of a permanent magnet surrounding the anode creating a magnetic field, the electrons travel an orbital path between the cathode and anode. As the electrons approach the anode, their orbital path takes them past small resonant cavities that are part of the anode. The passing motion of the electrons induces electron current to oscillate in the resonant cavities at the very high frequency or 2,450 MHz. This RF (Radio frequency) energy is then transferred to the antenna.

TESTING MAGNETRON TUBE

- * Disconnect power, remove the wrapper, and discharge the capacitor.
- * Remove the two leads from the magnetron terminals.
- * Connect the ohmmeter between one terminal of the magnetron and the outer case of the magnetron. If the ohmmeter reads infinity, go to below. If the ohmmeter reads less than infinity, the magnetron is shorted.
- * Connect an ohmmeter across the terminals of the magnetron. The ohmmeter should read less than one ohm_{meter} if the ohmmeter reads over one ohm or infinity, the tube is defective.

5-1. Multiwave system

What is Multi-Wave

- The multi-Wave system heats food more evenly than conventional microwave ovens.

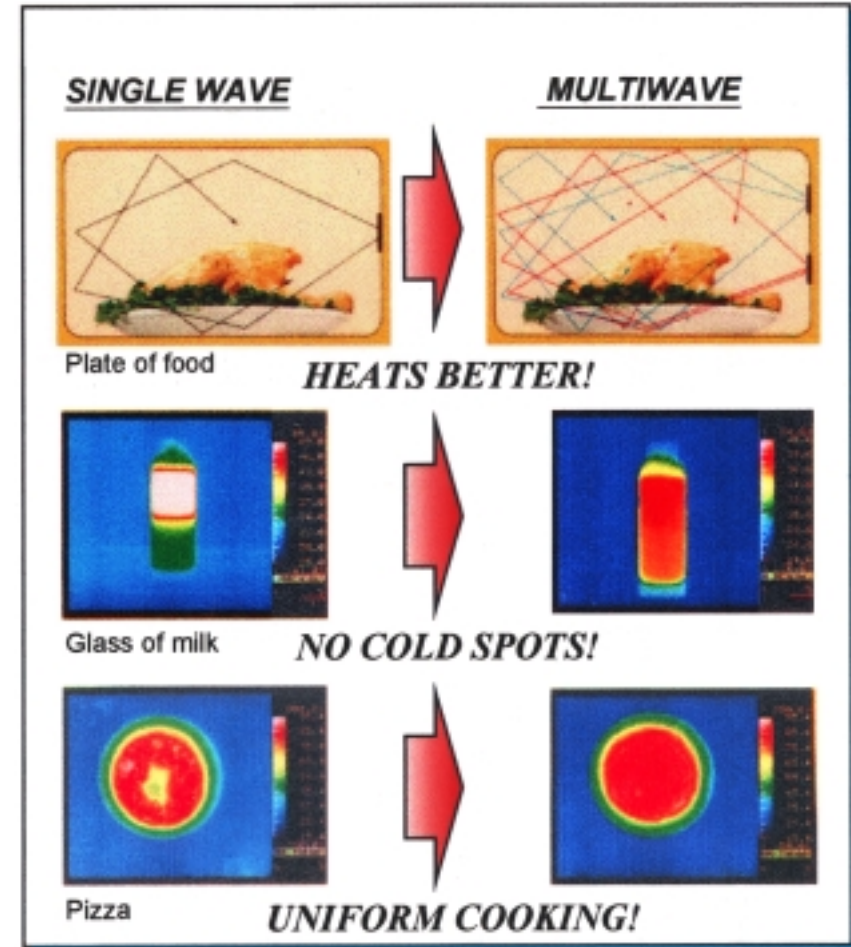
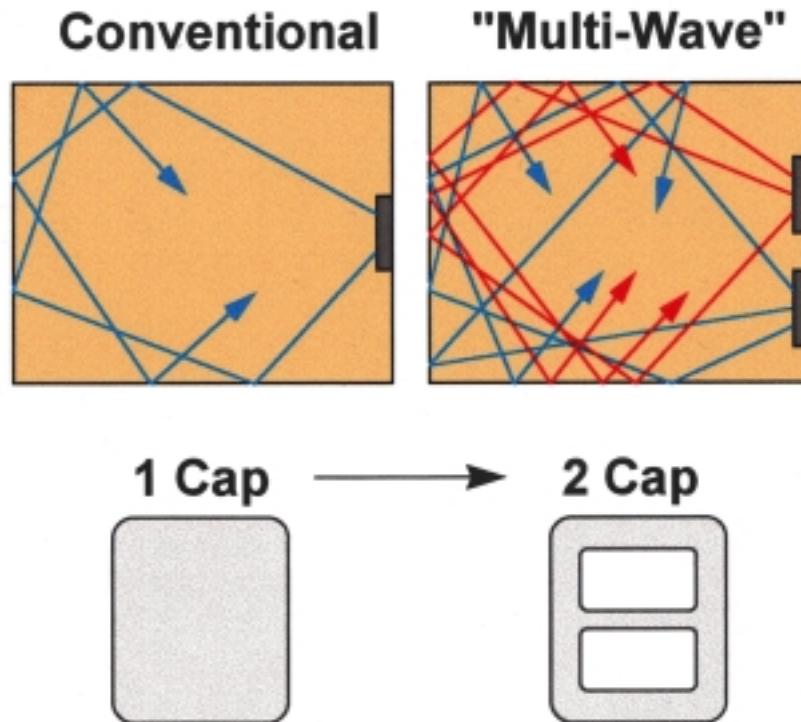

5-2. Infrared sensor

What's the infrared sensor?

You may be annoyed when you defrost or reheat food with microwave oven. If you reheat soup, the result is superficial. The surface is hot but inside of the soup is still cold. You have to set the clock and push "Start" again. The cooking time is much longer than you expected.

LG microwave oven reduce cooking time. Our revolutionary Infrared sensor makes it 3 times faster than the ordinary microwave. Infrared eye tracks the exact temperature of food and regulates the power of the microwave so that the temperature reaches you actually set.

We prepared the temperature LED bar and dial for your precise control and convenience.

Infrared sensor means fast and real hot result.

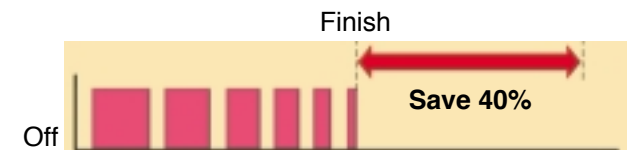
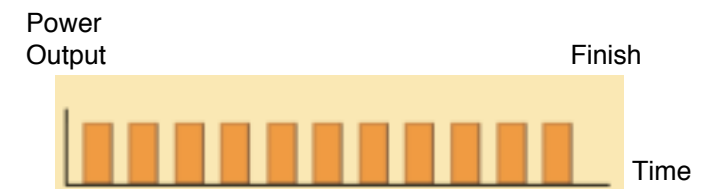

5-3. Auto moving heater

What's does move automatically?

Conventional microwave oven with grill has a heater on the ceiling of cooking room. Whether you cook a pizza or chicken, the position of heater is unmovable.

We changed the old way.

LG heater is moving when you choose grill, the heater goes down. The angle of heater varies as to each menu. You don't have to worry about safety. The heater moves back to it's position automatically after grilling. Your food is more evenly grilled and delicious when Auto Moving Heater.

Conventional Heater

- Sheath Heater



- Quartz Heater

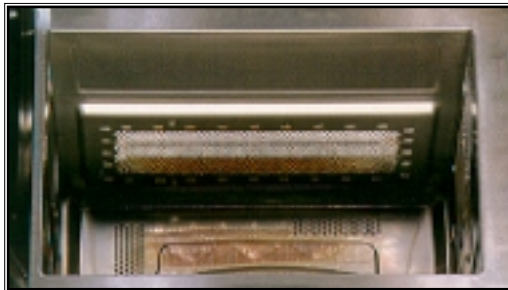

R&D

LG's Auto Moving Heater



- One-touch Grilling & Oven
 - Cookie → Heater 45°
 - Pizza, Frozen pizza, Chicken piece → Heater 90°
- When grilling, heater goes down automatically.

SPECIFICATIONS

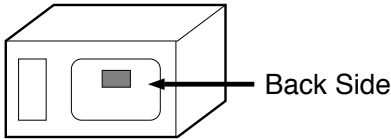
ITEM	DESCRIPTION
MODEL	MA-2005ST
Power Requirement	120 Volts AC 60 Hz 1,550 Watts (13.6 A) Single phase, 3 wire grounded
Power Output	1,150 Watts full microwave power (IEC705)
Microwave Frequency	2,450 MHz
Magnetron	2M246, 2M248J
Timer	0 ~ 99 min. 99 sec.
Outside Dimensions	23 ⁷ / ₈ " (W) x 13 ⁹ / ₁₆ " (H) x 18 ¹³ / ₁₆ " (D)
Cavity Dimensions	17 ¹ / ₁₆ " (W) x 10 ¹³ / ₁₆ " (H) x 18 ⁵ / ₁₆ " (D)
Net Weight	42 lbs (approx.)
Shipping weight	46 lbs (approx.)
Control Complement	Touch Control System Clock : 1:00 - 12:59 Microwave Power for Variable Cooking Power level HIGH -----Full power throughout the cooking time 9 (Saute) -----approx. 90% of Full power, 8 (Reheat) -----approx. 80% 7 (Med.-High) -----approx. 70%, 6 (Medium) -----approx. 60% 5 (Med.-Low) -----approx. 50%, 4 (Defrost) -----approx. 40% 3 (Low) -----approx. 30%, 2 (Simmer)-----approx. 20% 1 (Warm)-----approx. 10%
Nameplate Location	 <p>The diagram shows a 3D perspective view of the microwave oven's back panel. A rectangular nameplate is located on the right side of the panel. An arrow points from the text 'Back Side' to the nameplate.</p>
Accessories	Owner's manual & cooking guide Glass turntable Rotating ring
<p>This microwave oven is designed for household use only. It is not recommended for commercial purposes.</p>	

OPERATING INSTRUCTIONS

FEATURES

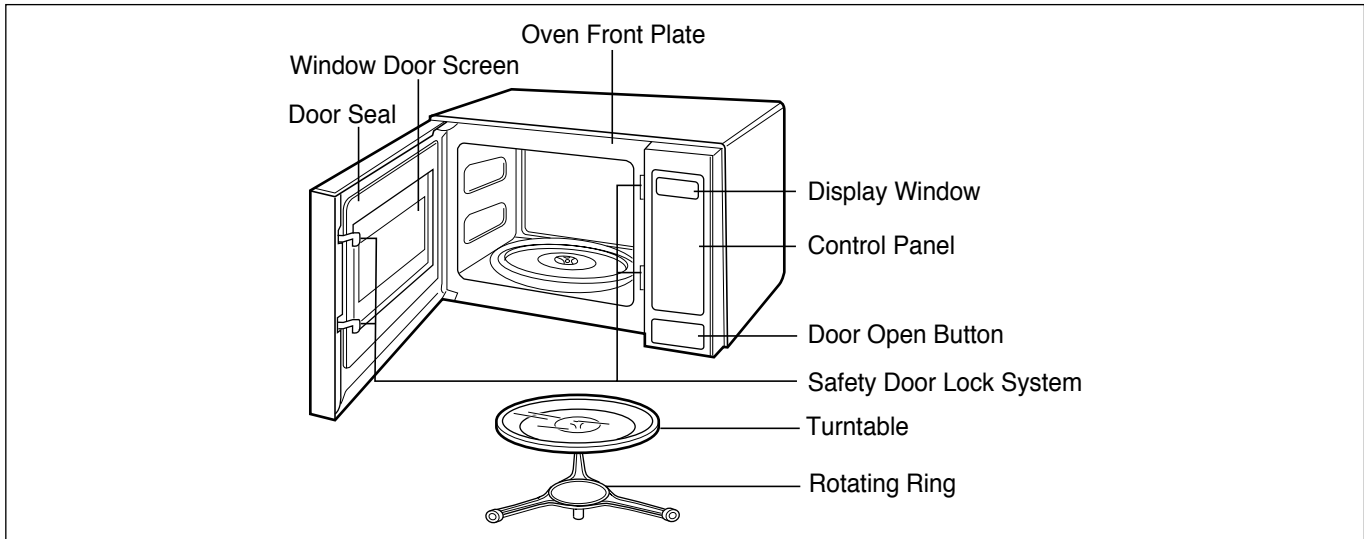

CONTROL PANEL

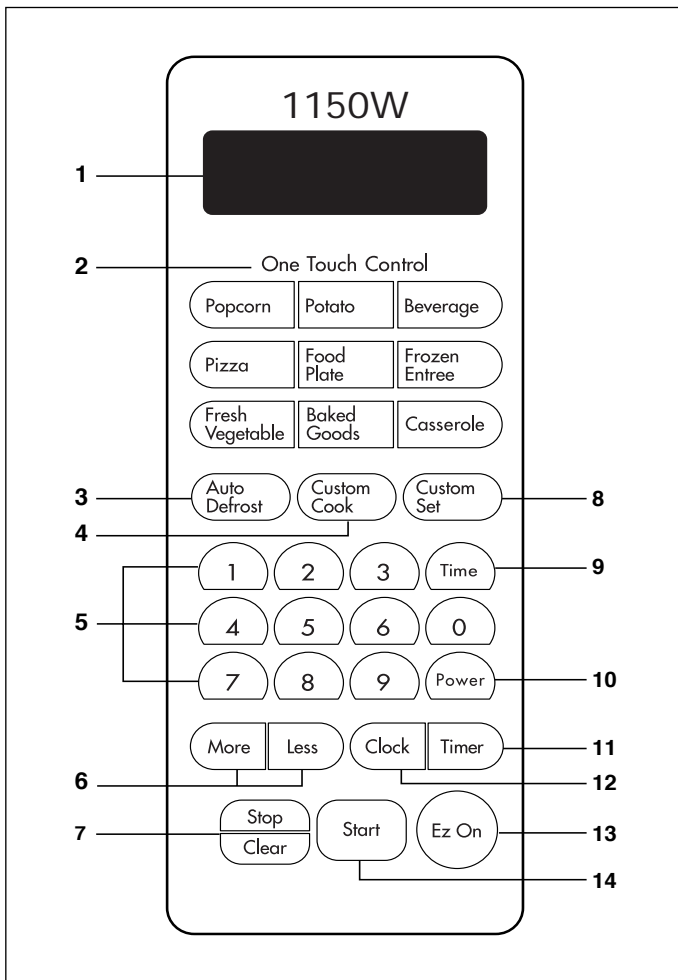

1. DISPLAY WINDOW.
2. ONE TOUCH CONTROL: This menu has been pre programmed to cook food automatically by one touch.
3. AUTO DEFROST: This feature provides you with the best defrosting method for frozen foods.
4. CUSTOM COOK: This feature allows you to set and execute a frequently used single stage program.
5. NUMBER: These used to set for time of day, cooking time, power level, or defrost weight.
6. MORE / LESS: All of the one touch cook and TIMED COOK can be adjusted to cook food for a longer or shorter time.
 MORE → Pressing MORE will add 10 seconds to the cooking time.
 LESS → Pressing LESS will subtract 10 seconds of cooking time.
7. STOP/CLEAR: It used to stop oven and clear all entries except time of day.
8. CUSTOM SET: You can select sound on/off, clock on/off, scroll speed, lbs/kg choice, language choice, demo on/off mode.
9. TIME: You can set the desired cook time.
10. POWER: You can select the desired power level for cooking.
11. TIMER: You can use the timer function of your oven for purpose other than cooking.
12. CLOCK: It is used to set the time of day.
13. EZ ON: You can extend cooking time in multiples of 1 minute by repeatedly touching this pad during cooking.
14. START: This feature allows oven to begin functioning.

OPERATING SEQUENCE

The following is a description of component functions during oven operation.

1. SETTING THE CLOCK



ex.) To set 4:30, touch number key [4],[3], and [0].

NOTE: 1) This is a 12 hour clock.

2) Clock will operate as long as power is applied to the oven.

2. CANCEL FUNCTION

Touch the **STOP/CLEAR** pad whenever you need to cancel an entry or a function currently in use.

The display will return either to the last item entered or to the clock.

3. EZ ON



4. ONE TOUCH COOKING



NOTE: Heat only 1 package at a time

5. TIME COOKING

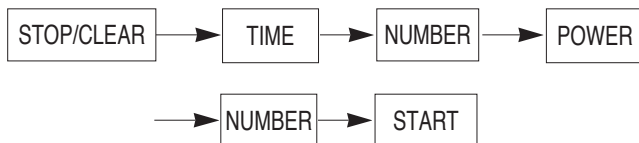

6. MULTI-STAGE COOKING

1ST STAGE

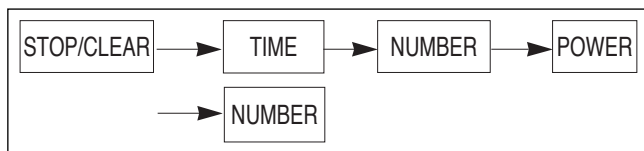

2ND STAGE

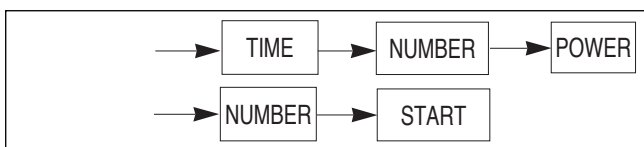

7. AUTO DEFROST COOKING



8. CHILD LOCK

This oven has a CHILD LOCK feature TO SET CHILD LOCK

• Touch and hold 0 pad → **LOCKED** appears on the display.

TO CANCEL CHILD LOCK

• Touch and hold 0 pad → **LOCKED** disappears.

9. MORE / LESS

The cook time is adjustable by MORE pad or LESS pad

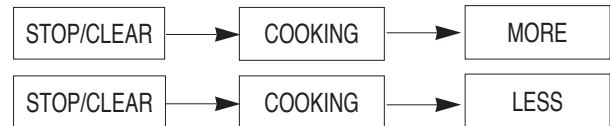

10. CUSTOM COOK

You can program the cook time and power level by using CUSTOM COOK pad.

ex) To set cook time 10 mine 30seconds, touch number key [1],[0],[3], and [0]

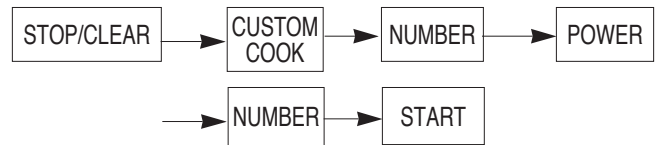

11. CUSTOM SET

You can select Sound On/Off, Clock On/Off, Scroll Speed, Lbs/Kg Choice, Demo On/Off modes.

• To turn ON/OFF sound.



• To select scroll speed



SCHEMATIC DIAGRAM

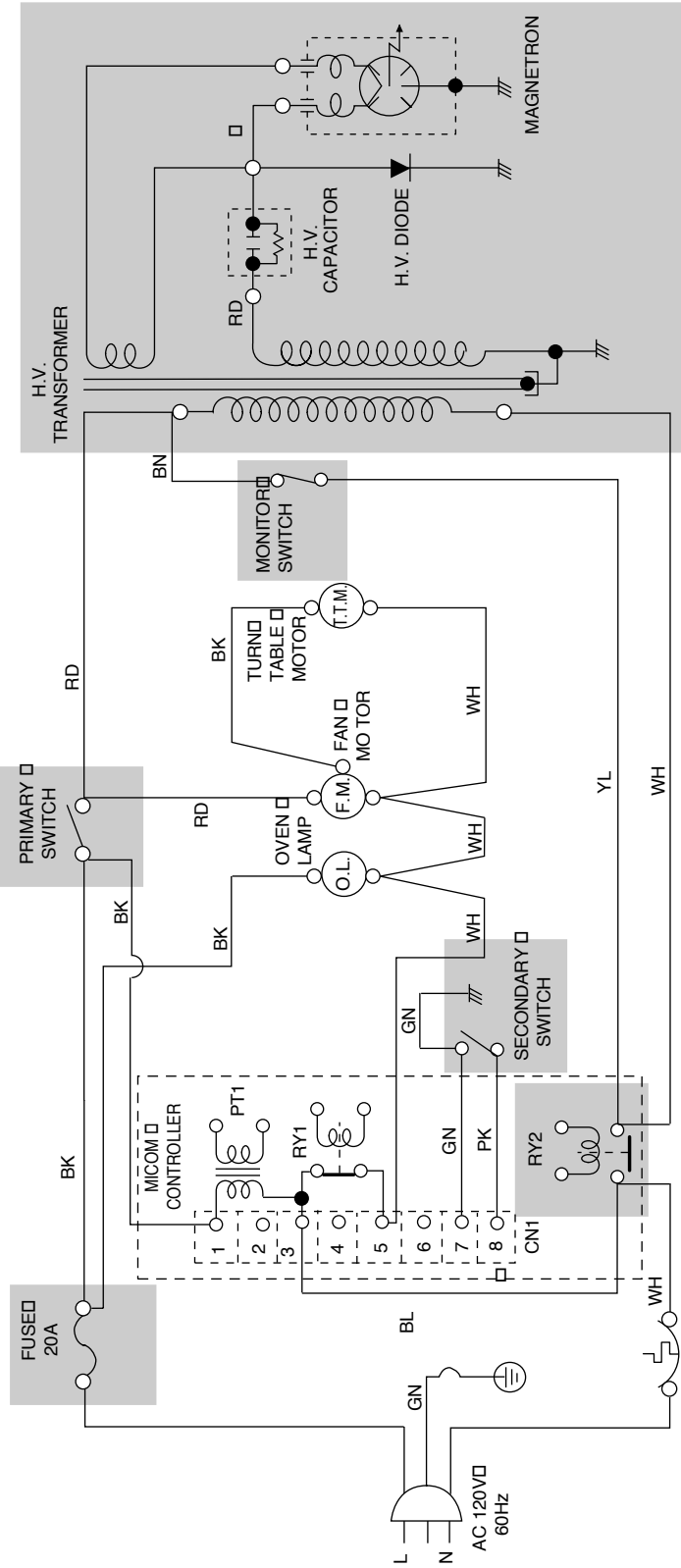

** NOTE : DOOR IS OPENED. □

BK : BLACK	BL : BLUE	YL : YELLOW	RD : REDD
WH : WHITE	PK : PINK	GN : GREEN	BN : BROWN

IMPORTANT SAFETY NOTE: THE SHADED AREAS ON THIS SCHEMATIC DIAGRAM INCORPORATE SPECIAL FEATURES □
 IMPORTANT FOR PROTECTION FROM MICROWAVE RADIATION, FIRE, ELECTRICAL SHOCK, AND □
 HAZARDS. WHEN SERVICING IT IS ESSENTIAL THAT ONLY MANUFACTURER'S SPECIFIED PARTS □
 BE USED FOR THE CRITICAL COMPONENTS IN THE SHADED AREAS OF THE SCHEMATIC DIAGRAM.

NOTICE: SINCE THIS IS BASIC SCHEMATIC DIAGRAM, THE VALUES OF COMPONENTS AND □
 SOME PARTIAL CONNECTIONS ARE SUBJECT TO CHANGE FOR IMPROVEMENT.

CIRCUIT DESCRIPTION

GENERAL DETAILS

- The low voltage transformer supplies the necessary voltage to the micom controller when power cord is plugged in.
- When the door is closed, the primary switch is ON, the secondary switch is ON, and the monitor switch opens (contact COM and NO).

WHEN SELECTING COOKING POWER LEVEL AND TIME

- The micom controller memorizes the function you set.
- The time you set appears in the display window.
- Each indicator light turns on to indicate that the stage has been set.

WHEN TOUCHING THE START PAD

- The coil of the relay is energized by the micom controller.
- Power input is supplied to the high voltage transformer through the fuse to the primary switch and relay 2.
- Turntable rotates.

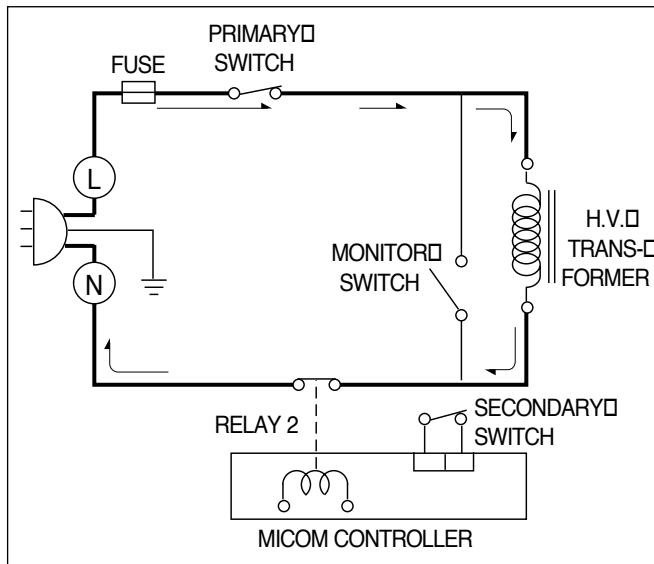

- The fan motor rotates and cools the magnetron by blowing the air (coming from the intake on the base-plate).
- The air is also directed into the oven to exhaust the vapor in the oven through the upper plate.
- Cooking time starts counting down.
- 3.3 volts AC is generated from the filament winding of the high voltage transformer. This 3.3 volts is applied to the magnetron to heat the magnetron filament through two noise-preventing choke coils.

- A high voltage of approximately 2100 volts AC is generated in the secondary of the high voltage transformer which is increased by the action of the high voltage diode and charging of the high voltage capacitor.
- The negative 4,000 Volts DC is applied to the filament of the magnetron.

WHEN THE OVEN IS SET AT ANY LEVEL EXCEPT MAXIMUM.

- The micom controller controls the ON-OFF time of relay 2 by the applied signal to vary the average output power of microwave oven as POWER LEVEL. (refer to page 1-1)
- One complete cycle of relay 2 is 22 seconds.

WHEN THE DOOR IS OPENED DURING COOKING

- Both the primary switch and relay 2 cut off the primary winding voltage of the high voltage transformer.
- ON-OFF of relay 2 is coupled electrically with opening and closing of the secondary switch.
- When the door is opened, the secondary switch is opened and when the door is closed, the secondary switch is closed.
- The cooking time stops counting down.
- Relay stops functioning.
- As the door is opened, if the contact of primary switch and relay2 and/or secondary switch fail to open, the fuse opens due to the large current surge caused by the monitor switch activation, which in turn stops magnetron oscillation.

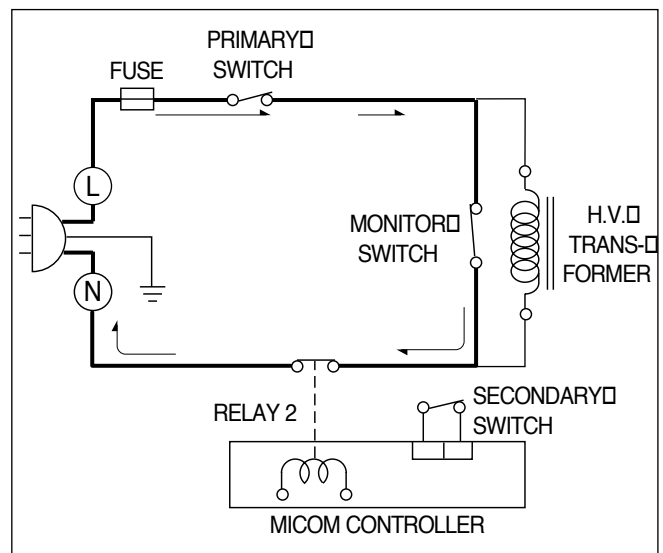

SERVICE INFORMATION

TOOLS AND MEASURING INSTRUMENTS

NECESSARY TOOLS

Tools normally used for TV servicing are sufficient. Standard tools are listed below.

- Diagonal pliers
- Long nose pliers
- Phillips screwdriver
- Flat blade screwdriver
- Wrench (size 5mm)
- Nutdriver (size 5mm)
- Adjustable wrench
- Soldering iron
- Solder
- Vinyl insulation tape
- Polishing cloth

NECESSARY MEASURING INSTRUMENTS

- TESTER (VOLTS-DC, AC, Ohmmeter)
- Microwave survey meter
 - Holaday HI-1500
HI-1501
 - Narda 8100
8200
- Inch scale
- 600 cc non conductive material beaker (glass or plastic),
inside diameter: approx. 8.5 cm (3¹/₂ in.)
- Cylindrical and made of borosilicate glass vessel.
max. thickness: 3 mm
outside diameter: approx. 190mm
height: approx. 90mm
- Glass thermometer: 100°C or 212°F (1 deg scale)

MICROWAVE LEAKAGE TEST

CAUTIONS

- **Be sure to check microwave leakage prior to servicing the oven if the oven is operative prior to servicing.**
- **The service personnel should inform the manufacture importer, or assembler of any certified oven unit found to have a microwave emission level in excess of 5 mW/cm² and should repair any unit found to have excessive emission levels at no cost to the owner and should ascertain the cause of the excessive leakage. The service personnel should instruct the owner not to use the unit until the oven has been brought into compliance.**
- **If the oven operates with the door open, the service personnel should:**
 - **Tell the user not to operate the oven.**
 - **Contact the manufacturer and CDRH (Center for Devices and Radiological Health) immediately.**

NOTE: Address on CDRH

Office of Compliance(HFZ-312)
Center for Devices and Radiological
Healthe 1390, Piccard Drive,
Rockville. MD 20850

- The service personnel should check all surface and vent openings for microwave leakage.
- Check for microwave leakage after every servicing. The power density of the microwave radiation leakage emitted by the microwave oven should not exceed 4 mW/cm². Always start measuring of an unknown field to assure safety for operating personnel from radiation leakage.

MEASURING MICROWAVE ENERGY LEAKAGE

- **Pour 275±15cc of 20±5°C(68±9°F) water in a beaker which is graduated to 600 cc, and place the beaker on the center of the turntable.**
- **Set the energy leakage monitor to 2,450 MHz and use it following the manufacturer's recommended test procedure to assure correct result.**
- **When measuring the leakage, always use the 2-inch (5cm) spacer supplied with the probe.**
- **Operate the oven at its maximum output.**
- **Measure the microwave radiation using and electromagnetic radiation monitor by holding the probe perpendicular to the surface being measured**

Move probe along shaded area

////////////////////////////////////

Probe scanning speed

Less than 2.5 cm/sec

(1 in/sec)

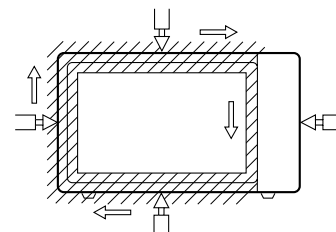

MEASUREMENT WITH OUTER CASE REMOVED

- When you replace the magnetron, measure for microwave energy leakage before the outer case is installed and after all necessary components are replaced or adjusted.
Special care should be taken in measuring the following parts. (Circled area of Fig. below)
 - Around the magnetron
 - The waveguide

WARNING : AVOID CONTACTING ANY HIGH VOLTAGE PARTS

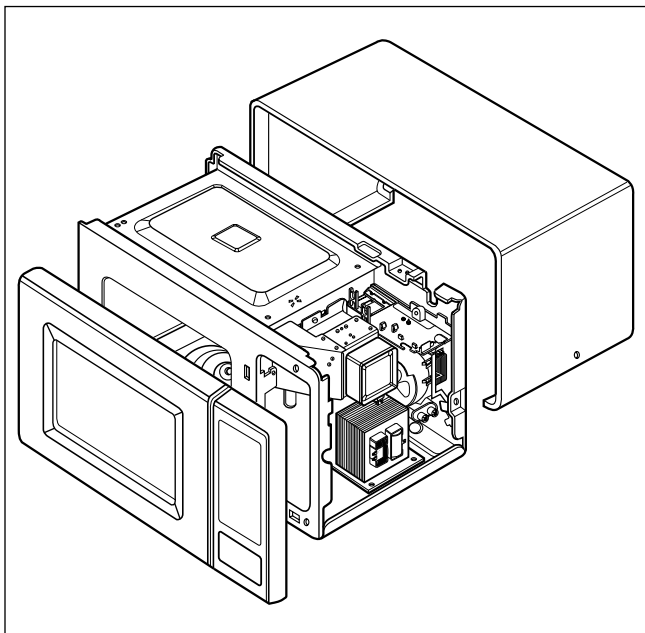

MEASUREMENT WITH A FULLY ASSEMBLED OVEN

- After all components, including the outer case, are fully assembled, measure for microwave energy leakage around the door viewing window, the exhaust opening, and air inlet openings.
- Microwave energy leakage must not exceed the values prescribed below.

NOTE: Leakage with the outer case removed less than 5 mW/cm.sq. Leakage for a fully assembled oven (Before the latch switch (primary) is interrupted) with the door in a slightly opened position-less than 2 mW/cm.sq.

NOTES WHEN MEASURING

- Do not exceed meter full scale deflection.
- The test probe must be removed no faster than 1 inch/sec (2.5 cm/sec) along the shaded area, otherwise a false reading may result.
- The test probe must be held with the grip portion of the handle.
A false reading may result if the operator's hand is between the handle and the probe.
- When testing near a corner of the door, keep the probe perpendicular to the surface making sure the probe horizontally along the oven surface; this may possibly cause probe damage.

RECORD KEEPING AND NOTIFICATION AFTER MEASUREMENT

- After adjustment and repair of any microwave energy interruption or microwave energy blocking device, record the measured values for future reference. Also enter the information on the service invoice.
- The microwave energy leakage should not be more than 4 mW/cm.sq. after determining that all parts are in good condition, functioning properly and genuine replacement parts which are listed in this manual have been used.
- At least once a year, have the electromagnetic energy leakage monitor checked for calibration by its manufacturer.

SPECIAL TIP

- This oven used the button head screws.

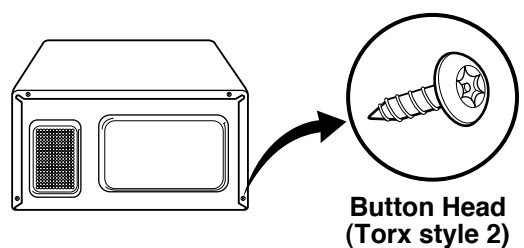

- When you remove the screws, use the tamper-resistant Torx driver having a pin-in-head.

MEASUREMENT OF MICROWAVE POWER OUTPUT

- Microwave power output measurement is made with the microwave oven supplied at its rated voltage and operated at its maximum microwave power setting with a load of (1000±5) g of potable water.
- The water is contained in a cylindrical borosilicate glass vessel having a maximum material thickness of 3 mm and an outside diameter of approximately 190mm.
- The oven and the empty vessel are at ambient temperature prior to the start of the test.
- The initial temperature (T1) of the water is (10±2)°C It is measured immediately before the water is added to the vessel. After addition of the water to the vessel, the load is immediately placed on the center of the turntable which is in the lowest position and the microwave power switched on.
- The time T for the temperature of the water to rise by a value ΔT of (10±2)°K is measured, where T is the time in seconds and ΔT is the temperature rise. The initial and final water temperatures are selected so that the maximum difference between the final water temperature and the ambient temperature is 5°K.

- The microwave power output P in watts is calculated from the following formula :

$$P = \frac{4187 \times (\Delta T)}{T}$$

is measured while the microwave generator is operating at full power. Magnetron filament heat-up time is not included. (about 3 sec)

- The water is stirred to equalize temperature throughout the vessel, prior to measuring the final water temperature.
- Stirring devices and measuring instruments are selected in order to minimize addition or removal of heat.

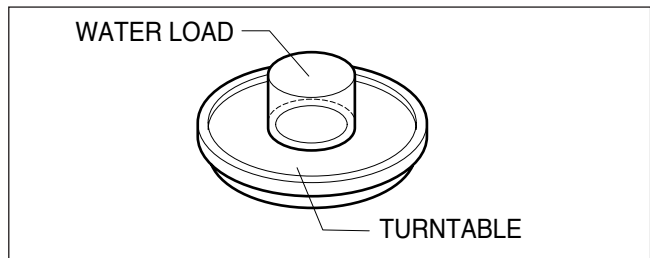

DISASSEMBLY AND ADJUSTMENT

A. OUTER CASE REMOVAL

- 1) Disconnect the power supply cord from the outlet.
- 2) Remove the screws from the rear of the case.
The outer case must be moved backward to be lifted off.

B. POWER SUPPLY CORD

- 1) Remove the outer case.
- 2) Disconnect two terminals, and remove one screw of the ground terminal.

C. CONTROL PANEL ASSEMBLY

- 1) Open the door.
- 2) Disconnect the leadwire from RELAY (RY2) of the PCB SUB ASS'Y.
- 3) Disconnect the leadwire from connector (CN1) of the PCB SUB ASS'Y.
- 4) Lift up and pull out control panel assembly carefully from the cavity.

CAUTION: DISCHARGE THE HIGH VOLTAGE CAPACITOR BEFORE SERVICING
(refer to page 2-1)

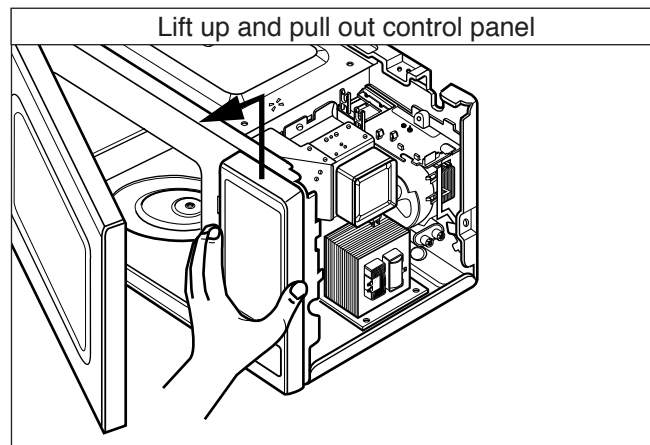
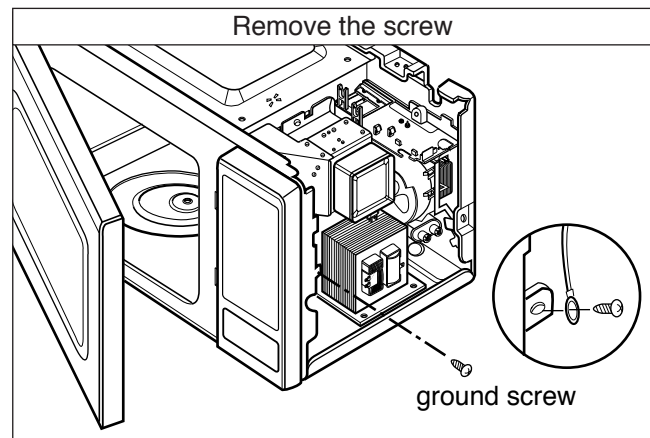

D. PCB ASSEMBLY REMOVAL

- 1) Remove the control panel assembly from the cavity. (Refer to control panel assembly removal on previous page.)
- 2) Remove screws which hold the PCB SUB ASS'Y to the control panel.
- 3) Disconnect the flat cable from the PCB SUB ASS'Y and take off the PCB SUB ASS'Y

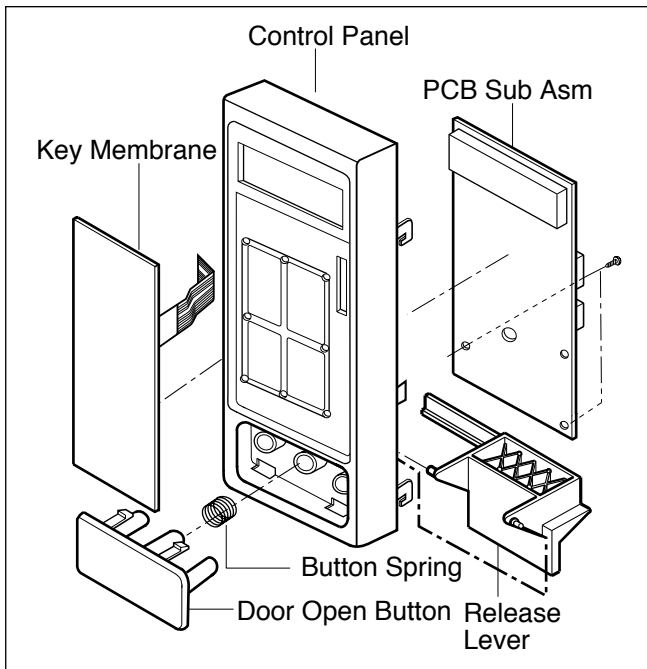

E. DOOR MAIN ASSEMBLY REMOVAL

- 1) Open the door.
- 2) Remove the choke cover very carefully with a flat-blade screwdriver.

CAUTION: Be careful not to damage door seal plate by screwdriver.

- 3) Lift up and push the door.

NOTE:

1. After replacing the door, be sure to check that the primary switch, monitor switch, and secondary switch operate normally.
2. After replacing the door, check for microwave energy leakage with a survey meter. Microwave energy must be below the limit of 4 mW/cm. (with a 275 ml water load)
3. When mounting the door assembly to the oven assembly, be sure to adjust the door assembly parallel to the chassis. Also adjust so the door has no play between the inner door surface and oven frame assembly. If the door assembly is not mounted properly, microwaves may leak from the clearance between the door and the oven.

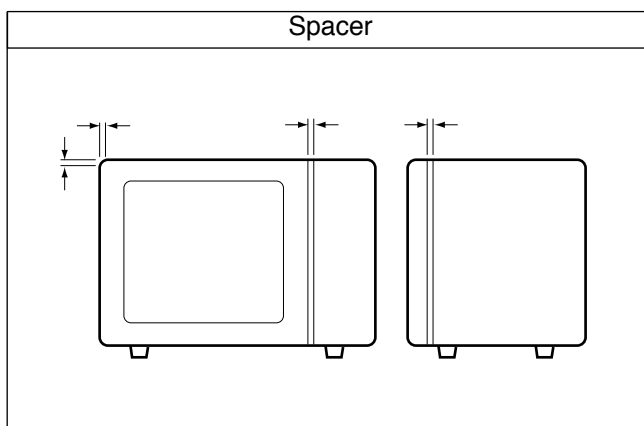
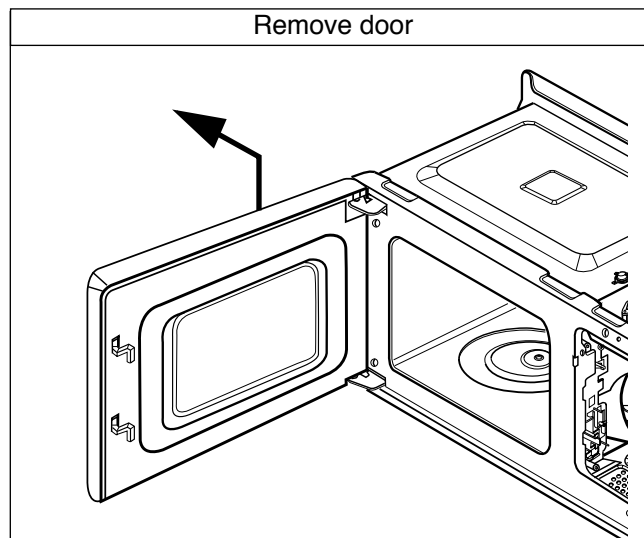
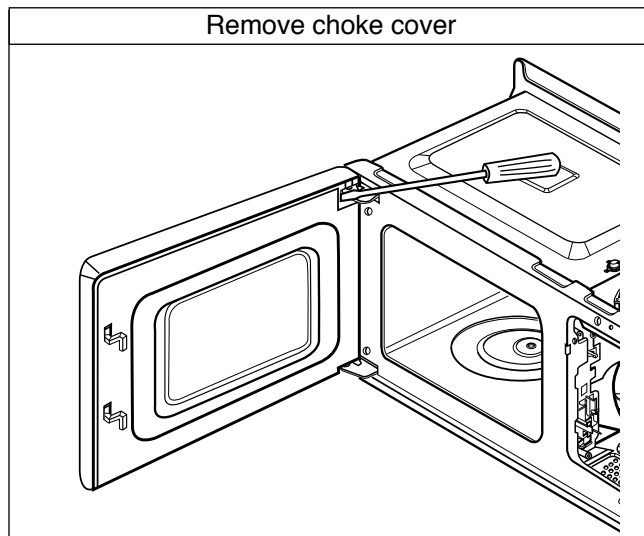

F. AIR DUCT ASSEMBLY REMOVAL

- 1) Disconnect the leadwire from the lamp.
- 2) Remove the mounting screw to the magnetron.

G. MAGNETRON REMOVAL

- 1) Disconnect the leadwire from the magnetron.
- 2) Carefully remove the mounting screws holding the magnetron and the waveguide.
- 3) Remove the magnetron ASS'Y until the tube is clear from the waveguide.

NOTE:

1. When removing the magnetron, make sure its dome does not hit any adjacent parts, or it may be damaged.
2. When replacing the magnetron, be sure to install the magnetron gasket in the correct position and be sure that the gasket is in good condition.
3. After replacing the magnetron, check for microwave leakage with a survey meter around the magnetron. Microwave energy must be below the limit of 5 mW/cm^2 . (With a 275 ml. water load).
Make sure that gasket is rigidly attached to the magnetron. To prevent microwave leakage, tighten the mounting screws properly, making sure there is no gap between the waveguide and the magnetron.

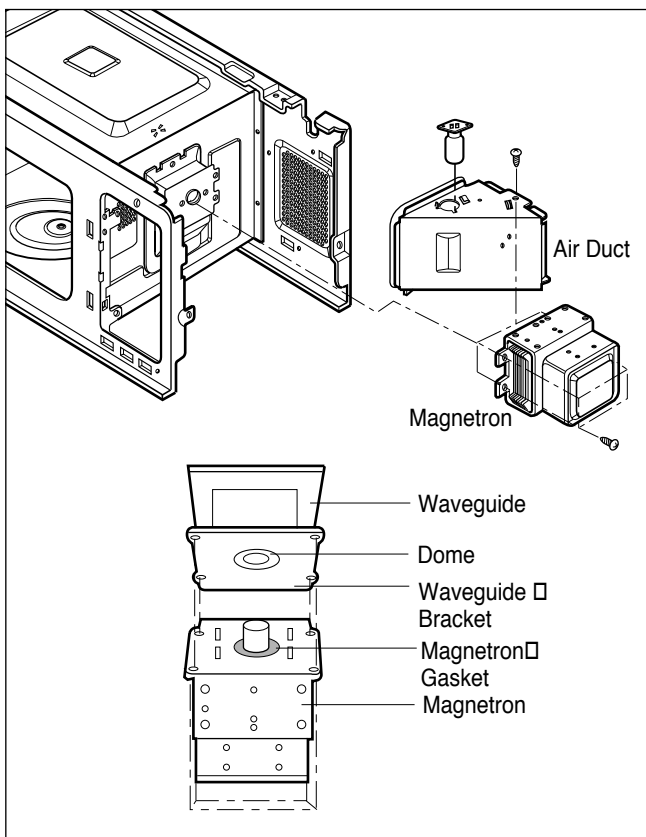

H. REMOVING THE TURNTABLE MOTOR

- 1) Remove the turntable and rotating ring.
- 2) Lay the unit down on its back.
- 3) Remove the turntable motor cover.
The turntable base cover is easily removed by pinching the eight parts with a wire cutting.
- 4) Disconnect the leadwire from the turntable motor terminals.
- 5) Remove the screw securing the turntable motor to the oven cavity ASS'Y
- 6) After repairing the motor, rotate the removed turntable motor cover.
- 7) Fit the turntable motor cover's projecting part to the base plate slit.

NOTE:

1. Remove the wire lead from the turntable motor **VERY CAREFULLY**.
2. Be sure to grasp the connector, not the wires, when removing.

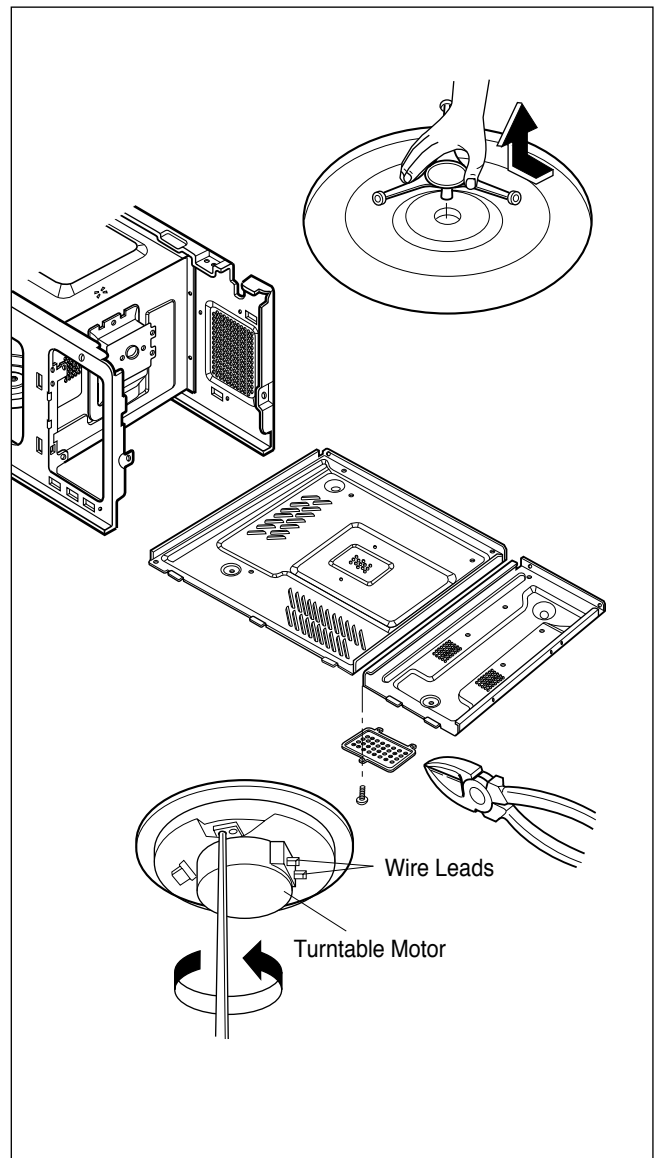

I. HIGH VOLTAGE TRANSFORMER REMOVAL

- 1) Discharge the high voltage capacitor.
- 2) Disconnect the leadwire from magnetron, high voltage transformer, and capacitor.
- 3) Remove the screw holding the high voltage transformer to the baseplate.

J. FAN MOTOR ASSEMBLY REMOVAL

- 1) Discharge the high voltage capacitor.
- 2) Disconnect the leadwire from fan motor and high voltage capacitor.
- 3) Remove the two screws holding the the suction guide ASS'Y to the oven cavity and remove the high voltage diode earth screw.
- 4) Remove the two screws holding the fan motor ASS'Y to the suction guide ASS'Y.

K. HIGH VOLTAGE CAPACITOR AND DIODE REMOVAL

- 1) Discharge the high voltage capacitor.
- 2) Disconnect the leadwire from fan motor and high voltage capacitor.
- 3) Remove the screw holding the suction guide ASS'Y to the oven cavity and remove the high voltage diode earth screw.
- 4) Remove the screw holding the high voltage capacitor bracket.

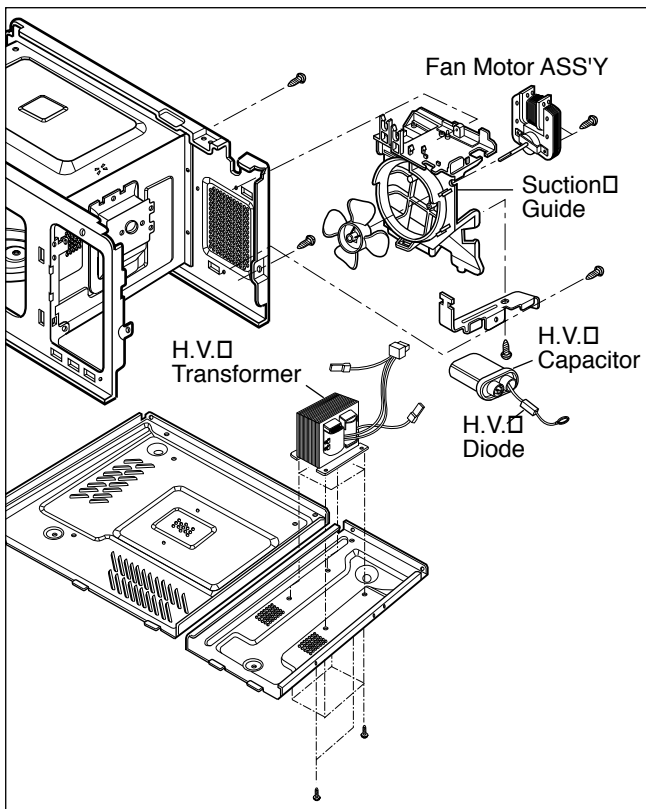

L. INTERLOCK SYSTEM

1) INTERLOCK MECHANISM

The door lock mechanism is a device which has been specially designed to eliminate completely microwave activity when the door is opened during cooking and thus to prevent the danger resulting from the microwave leakage.

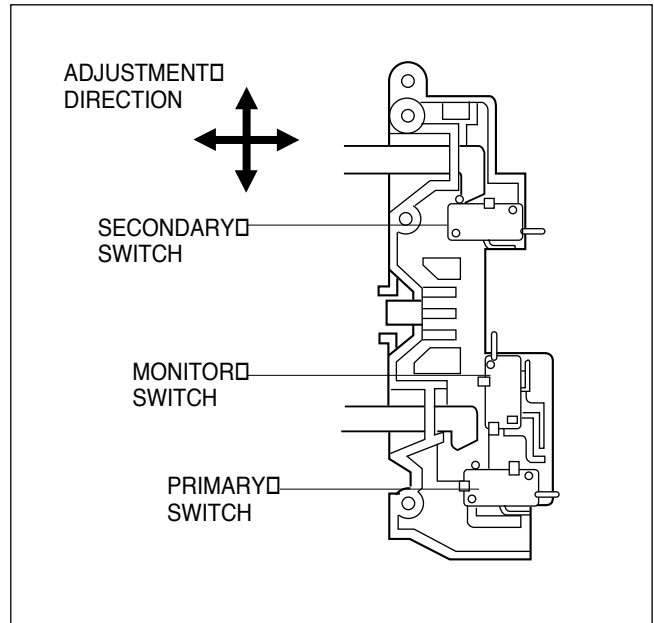

2) MOUNTING OF THE PRIMARY/MONITOR/ SECONDARY SWITCHES TO THE LATCH BOARD

3) INSTALLATION AND ADJUSTMENT OF THE LATCH BOARD TO THE OVEN ASSEMBLY

- Mount the latch board to the oven assembly.
- Adjust the latch board in the arrow direction so that oven door will not have any play in it when the door is closed.
- Tighten the mounting screw.
- **Check for play in the door by pushing the door release button. Door movement should be less than 0.5 mm. (1/64 inch)**

Don't push the door release button while making this adjustment. Make sure that the latch moves smoothly after adjustment is completed and that the screws are tight. Make sure the primary, monitor, and secondary switches operate properly by following the continuity test procedure.

INTERLOCK CONTINUITY TEST

WARNING : FOR CONTINUED PROTECTION AGAINST EXCESSIVE RADIATION EMISSION, REPLACE ONLY WITH IDENTICAL REPLACEMENT PARTS.

TYPE NO. SZM-V 16-FA-63 OR VP-533A-OF FOR PRIMARY SWITCH
 TYPE NO. SZM-V 16-FA-62 OR VP-532A-OF FOR MONITOR SWITCH
 TYPE NO. SZM-V 16-FA-63 OR VP-533A-OF FOR SECONDARY SWITCH

A. PRIMARY INTERLOCK SWITCH TEST

When the door release button is depressed slowly with the door closed, an audible **click** should be heard at the same time or successively at intervals. When the button is released slowly, the latches should activate the switches with an audible **click**.

If the latches do not activate the switches when the door is closed, the switches should be adjusted in accordance with the adjustment procedure. Disconnect the wire lead from the primary switch. Connect the ohmmeter leads to the common (COM) and normally open (NO) terminal of the switch. The meter should indicate an open circuit in the door open condition. When the door is closed, the meter should indicate a closed circuit.

When the primary switch operation is abnormal, make the necessary adjustment or replace the switch only with the same type of switch.

B. SECONDARY INTERLOCK SWITCH TEST







Disconnect the wire lead from the secondary switch.

Connect the ohmmeter leads to the common (COM) and normally open (NO) terminals of the switch. The meter should indicate a open circuit in the door open condition. When the door is closed, meter should indicate an closed circuit. When the secondary switch operation is abnormal, make the necessary adjustment or replace the switch only with the same type of switch.

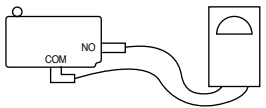
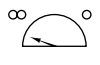
C. MONITOR SWITCH TEST

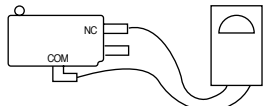
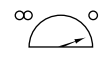
Disconnect the wire lead from the monitor switch. Connect the ohmmeter leads to the common (COM) and normally closed (NC) terminals of the switch. The meter should indicate closed circuit in the door open condition. When the door is closed, meter should indicate an open circuit. When the monitor switch operation is abnormal, replace with the same type of switch.

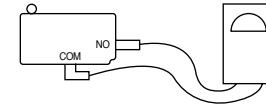
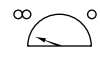
NOTE: After repairing the door or the interlock system, it is necessary to do this continuity test before operating the oven.

COMPONENTS	TEST PROCEDURE	RESULTS	
		Door open	Door closed
SWITCHES (Wire leads removed)	Check for continuity of the switch with an Ohm-meter		
	Primary Switch 		
	Monitor Switch 		
	Secondary Switch 		
NOTE : After checking for the continuity of switches, make sure that they are connected correctly.			



COMPONENT TEST PROCEDURE

CAUTIONS

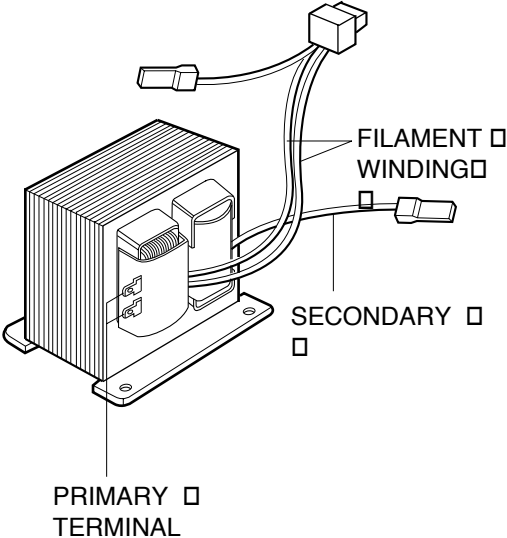
1. DISCONNECT THE POWER SUPPLY CORD FROM THE OUTLET WHENEVER REMOVING THE OUTER CASE FROM THE UNIT. PROCEED WITH THE TEST ONLY AFTER DISCHARGING THE HIGH VOLTAGE CAPACITOR AND REMOVING THE WIRE LEADS FROM THE PRIMARY WINDING OF THE HIGH VOLTAGE TRANSFORMER. (SEE PAGE 2-1)
2. ALL OPERATIONAL CHECKS WITH MICROWAVE ENERGY MUST BE DONE WITH A LOAD (1 LITER OF WATER IN CONTAINER) IN THE OVEN.

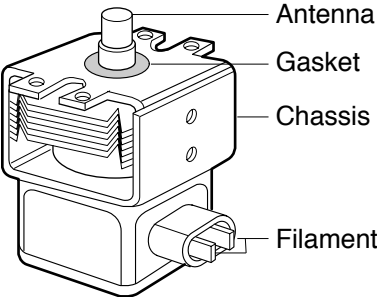
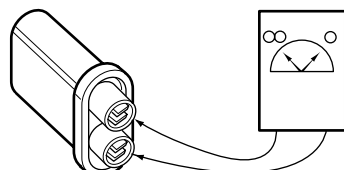
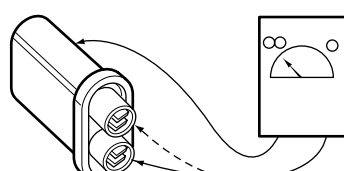
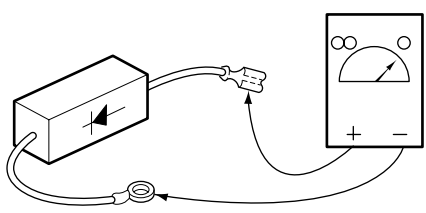
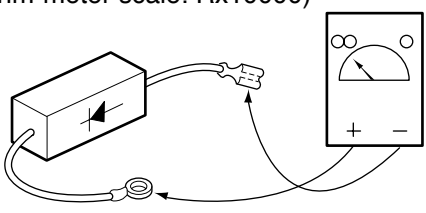
COMPONENTS	TEST PROCEDURE	RESULTS
<p>HIGH VOLTAGE TRANSFORMER (Wire leads removed)</p>	 <p>1. Measure the resistance. (Ohm-meter scale: Rx1 and Rx100)</p> <ul style="list-style-type: none"> • Primary winding • Secondary winding • Filament winding <p>2. Measure the resistance. (Ohm-meter scale: Rx1000)</p> <ul style="list-style-type: none"> • Primary winding to ground • Filament winding to ground 	<p>Approx.: 0.2 ~ 0.4 ohm Approx.: 60 ~ 90 ohm Less than: 1 ohm</p> <p>Normal: Infinite Normal: Infinite</p>
<p>MAGNETRON (Wire leads removed)</p>	<p>1. Measure the resistance. (Ohm-meter scale: Rx1)</p> <ul style="list-style-type: none"> • Filament terminal <p>2. Measure the resistance. (Ohm-meter scale: Rx1000)</p> <ul style="list-style-type: none"> • Filament to chassis 	<p>Normal: Less than 1 ohm</p> <p>Normal: Infinite</p>

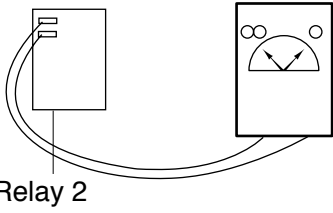
COMPONENTS	TEST PROCEDURE	RESULTS
	 <p>NOTE: When testing the magnetron, be sure to install the magnetron gasket in the correct position and be sure that the gasket is in good condition.</p>	
HIGH VOLTAGE CAPACITOR	<p>Measure the resistance. (Ohm-meter scale: Rx1000) • Terminal to terminal.</p> 	Normal: Momentarily indicates several ohms, and then gradually returns to infinite.
	<p>Measure the resistance. (Ohm-meter scale: Rx1000) • Terminal to case.</p> 	Normal: Infinite.
HIGH VOLTAGE DIODE	<p>Measure the continuity (Forward). (Ohm-meter scale: Rx10000)</p> 	Normal: Continuity. Abnormal: Infinite.
NOTE : Some inexpensive meters may indicate infinite resistance in both direction.	<p>Measure the continuity (Reverse). (Ohm-meter scale: Rx10000)</p> 	Normal: Infinite. Abnormal: Continuity.

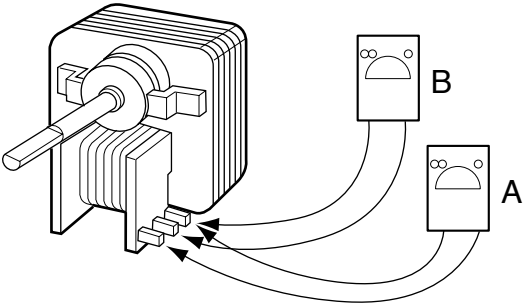
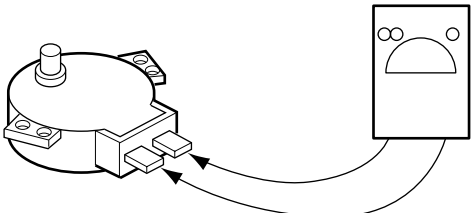
COMPONENTS	TEST PROCEDURE	RESULTS		
RELAY 2	<p>Check for continuity of relay 2 with an ohm-meter. (Remove wire leads from relay 2 and operate the unit.)</p>  <p style="text-align: center;">Relay 2</p>	POWER LEVEL		
FAN MOTOR (Wire leads removed)	<p>Measure the resistance. (Ohm-meter scale: R x 1)</p> 	<p>Normal: A: Approx. 85 ~ 100 ohm. B: Approx. 10 ~ 25 ohm.</p> <p>Abnormal: Infinite or several ohm.</p>		
TURNTABLE MOTOR (Wire leads removed)	<p>Measure the resistance. (Ohm-meter scale: R x 1)</p> 	<p>Normal: Approx. 100~150 ohm Abnormal: Infinite or several ohm.</p>		
<p>NOTE :</p> <ul style="list-style-type: none"> • A MICROWAVE LEAKAGE TEST MUST ALWAYS BE PERFORMED WHEN THE UNIT IS SERVICED FOR ANY REASON. • MAKE SURE THE WIRE LEADS ARE IN THE CORRECT POSITION. • WHEN REMOVING THE WIRE LEADS FROM THE PARTS, BE SURE TO GRASP THE CONNECTOR, NOT THE WIRES. 				

TROUBLE SHOOTING

WHEN YOU GET A COMPLAINT FROM YOUR CUSTOMER, EVALUATE THE COMPLAINT CAREFULLY. IF THE FOLLOWING SYMPTOMS APPLY, PLEASE INSTRUCT THE CUSTOMER IN THE PROPER USE OF THE MICROWAVE OVEN. THIS CAN ELIMINATE AN UNNECESSARY SERVICE CALL.

CAUTIONS

1. Check grounding before checking for trouble.
2. Be careful of the high voltage circuit.
3. Discharge the high voltage capacitor. (See page 2-1)
4. When checking the continuity of the switches or of the high voltage transformer, disconnect one lead wire from these parts and then check continuity with the AC plug removed. To do otherwise may result in a false reading or damage to your meter.
5. Do not touch any part of the circuit on the PCB since static electric discharge may damage this control panel.

Always touch yourself to ground while working on this panel to discharge any static charge built up in your body. (Micom model only)

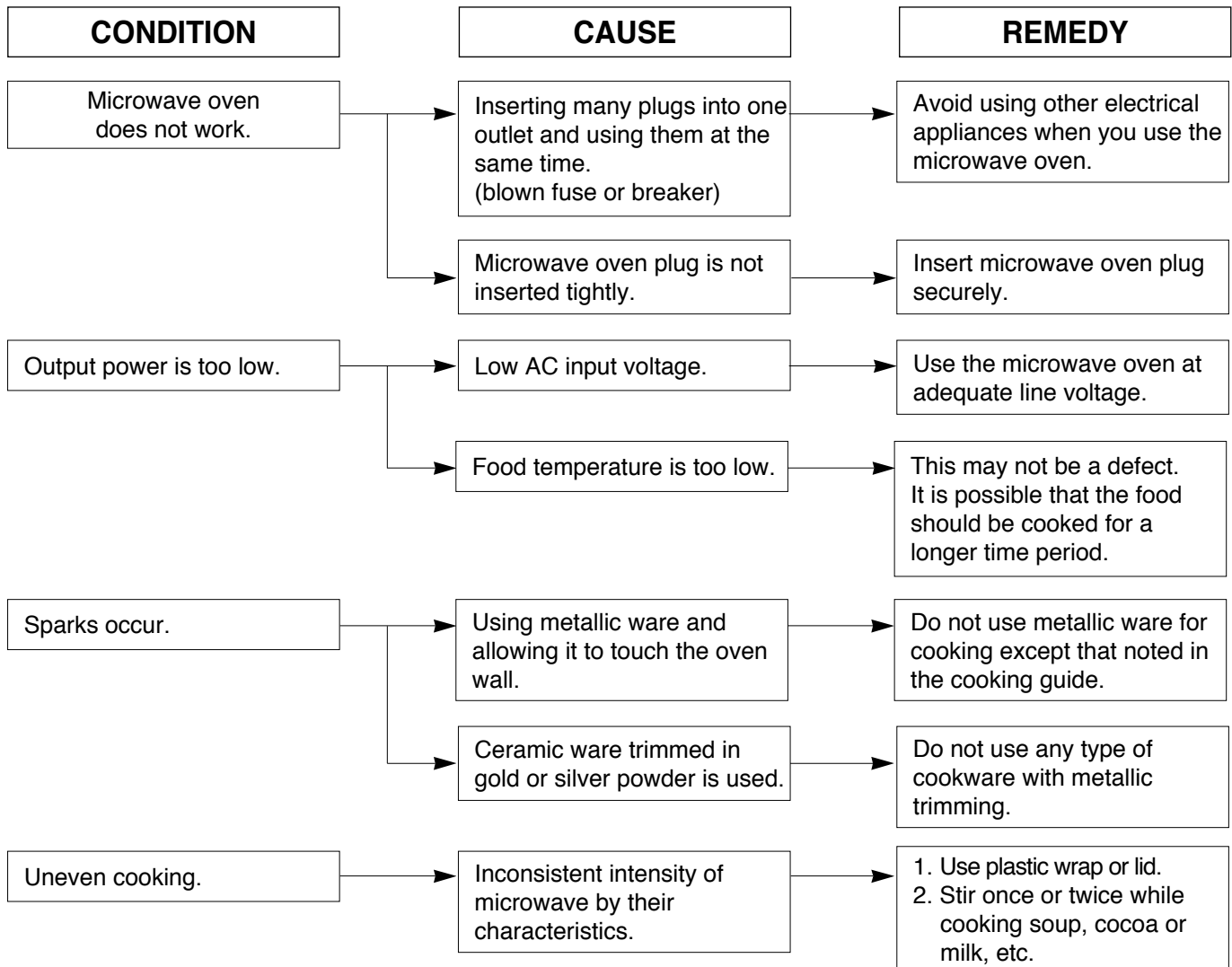

(TROUBLE 1) The following visual conditions indicate a probable defective control circuit.

1. Incomplete segments.
 - Segment missing.
 - Partial segment missing.
 - Digit flickering (NOTE: Slight flickering is normal.)
2. Colon does not turn on or blink.
3. A distinct change in the brightness of one or more numbers in display.
4. One or more digits in the display are not lighting.
5. Display indicates a number different from one touched, for example, key in **5** and **3** appears in the display.
6. Specific numbers (for example 7 or 9) will not display when key pad is touched.
7. Display does not count down with time blinking or up with clock operation.
8. Display obviously jumps in time while counting down.
9. Display counts down too fast while cooking.
10. Each indicator light does not turn on after setting cooking cycle.
11. Display time of day does not reappear when cooking is finished.

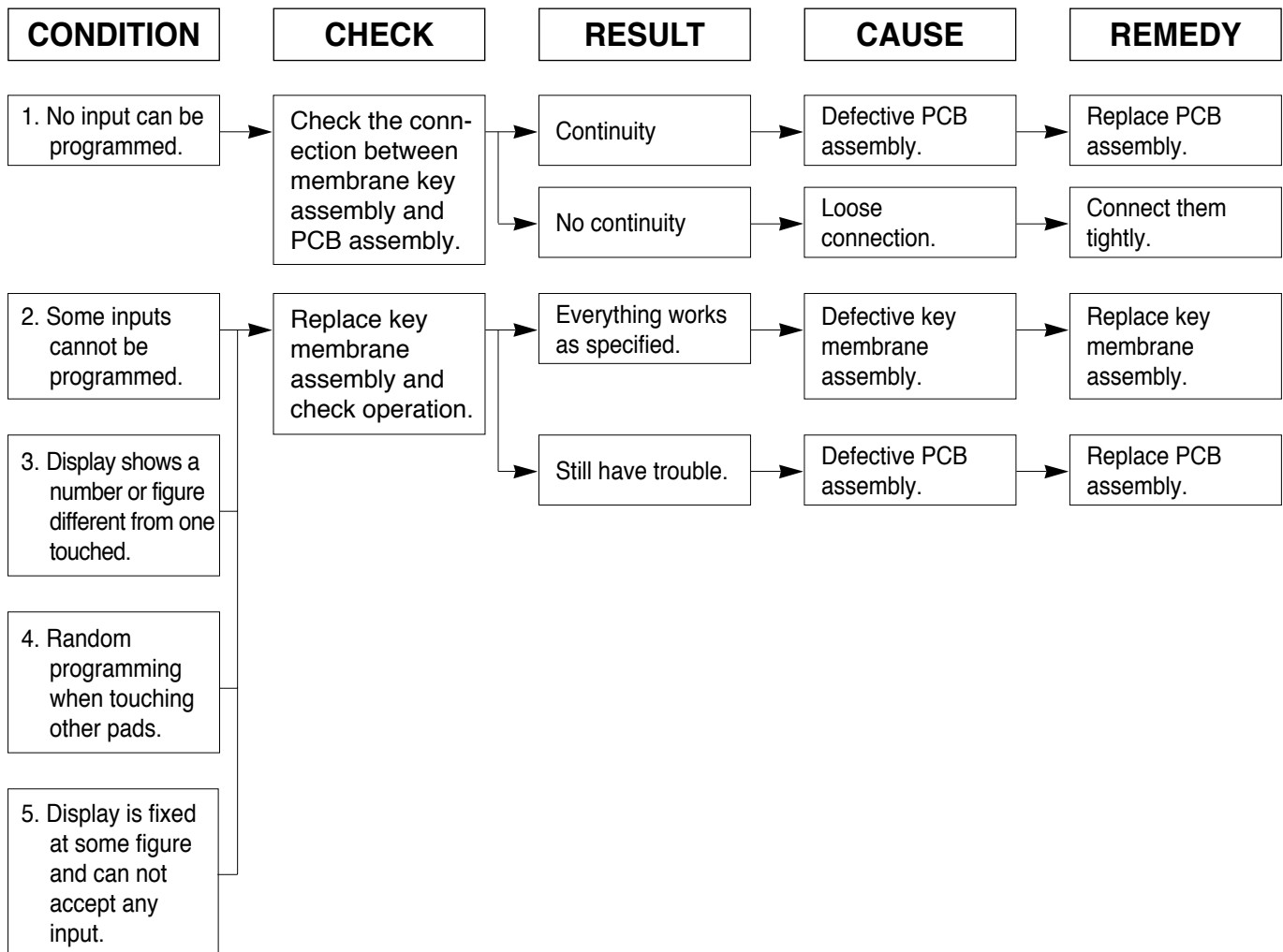

(TROUBLE 2) Oven does not operate at all, Display window does not display any figures, and no input is accepted.

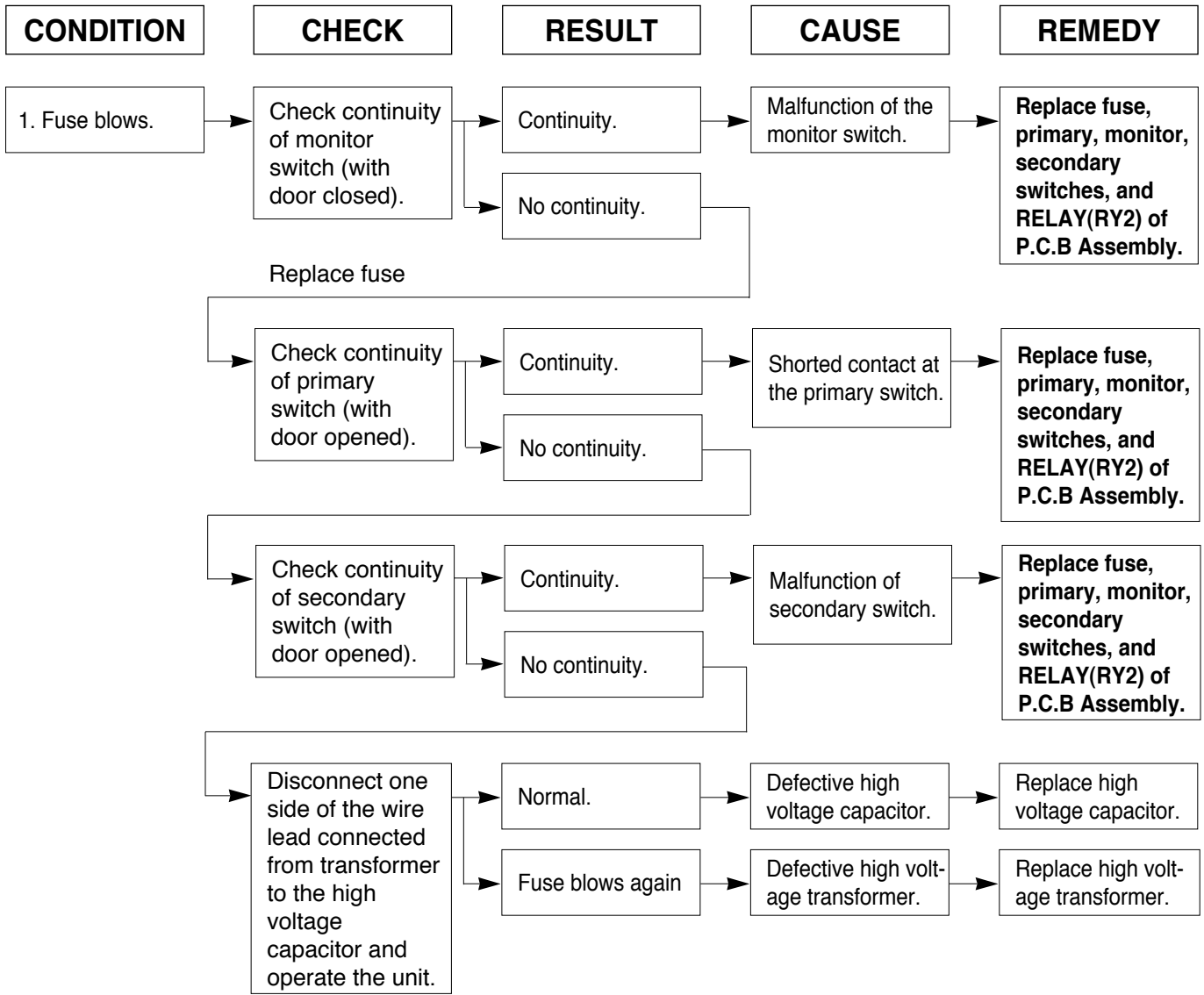

NOTE : All these switches must be replaced at the same time. Refer to page 5-7, 5-8

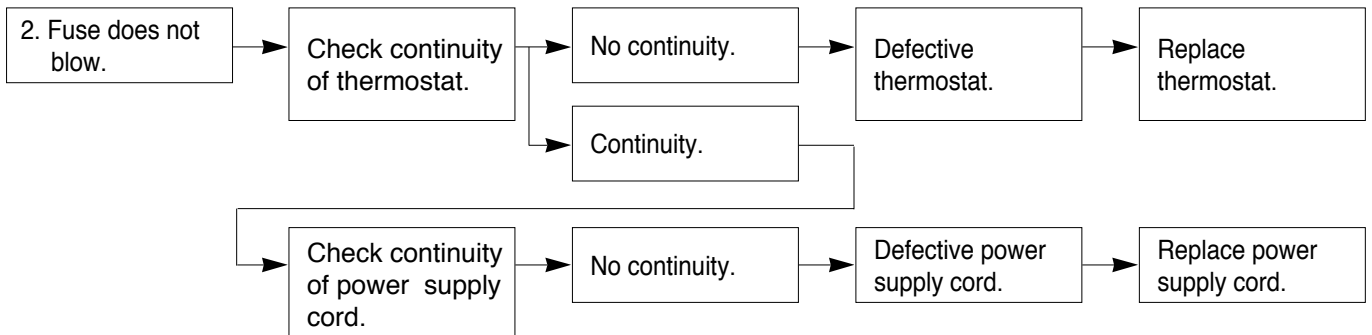

(TROUBLE 3) Display shows all figures set, but oven does not start cooking while desired program times are set and START pad is touched.

CONDITION	CHECK	RESULT	CAUSE	REMEDY
1. Setting time does not count down when touching START pad.	Check continuity of secondary switch (with door closed).	No continuity.	Defective secondary switch.	Replace secondary switch.
		Continuity.		
	Check the connection between CN1 connector and PCB assembly.	Continuity	Defective PCB assembly.	Replace PCB assembly.
		No continuity	Loose connection.	Connect them tightly.
2. Fan motor or oven lamp do not turn on.	Check fan motor.	Abnormal	Defective fan motor.	Replace fan motor.
	Check oven lamp.	Abnormal	Defective oven lamp.	Replace oven lamp.
		Normal		

(TROUBLE 4) Oven seems to be operating but little heat is produced in oven load.

CONDITION	CHECK	RESULT	CAUSE	REMEDY
Output is low	Check the power source voltage.	Lower than 90% of rating voltage.	Decrease in power source voltage with load.	Suggest customer contact local electric power utility co. or qualified electrician.
		Normal		
	Disconnect the wire leads from relay 2 and check on and off time with multimeter.	Abnormal	Defective PCB assembly.	Replace PCB assembly.
		Normal		
	Measure the output power.	Abnormal	Defective magnetron.	Replace magnetron.

NOTE : Simple test of power output-conducted by heating one liter water for one min. if available. Minimum 8.5°C temperature rise is normal condition.

**(TROUBLE 5) No microwave oscillation even though oven lamp and fan motor run.
(Display operates properly)**

CONDITION	CHECK	RESULT	CAUSE	REMEDY
No microwave oscillation.	Disconnect the wire leads from relay 2 and check continuity of relay 2. (Operate the unit)	No continuity.	Defective PCB assembly.	Replace PCB assembly.
		Continuity.		
	Check high voltage transformer	Abnormal	Defective high voltage transformer.	Replace high voltage transformer.
		Normal		
	Check high voltage capacitor.	Abnormal	Defective high voltage capacitor.	Replace high voltage capacitor.
		Normal		
	Check high voltage diode.	Abnormal	Defective high voltage diode.	Replace high voltage diode.
		Normal		
	Check magnetron.	Abnormal	Defective magnetron.	Replace magnetron.

NOTE : • Make sure the wire leads correct position.

- When Removing the wire leads from the parts, be sure to grasp the connector, not the wires.
- When removing the magnetron, be sure to install the magnetron gasket in the correct position and in good condition.

Output is full power when you set lower power level.	Disconnect the wire leads from relay 2 and check continuity relay 2. (Operate the unit)	Abnormal.	Defective PCB assembly.	Replace PCB assembly.
--	--	-----------	-------------------------	-----------------------

EXPLODED VIEW

INTRODUCTION

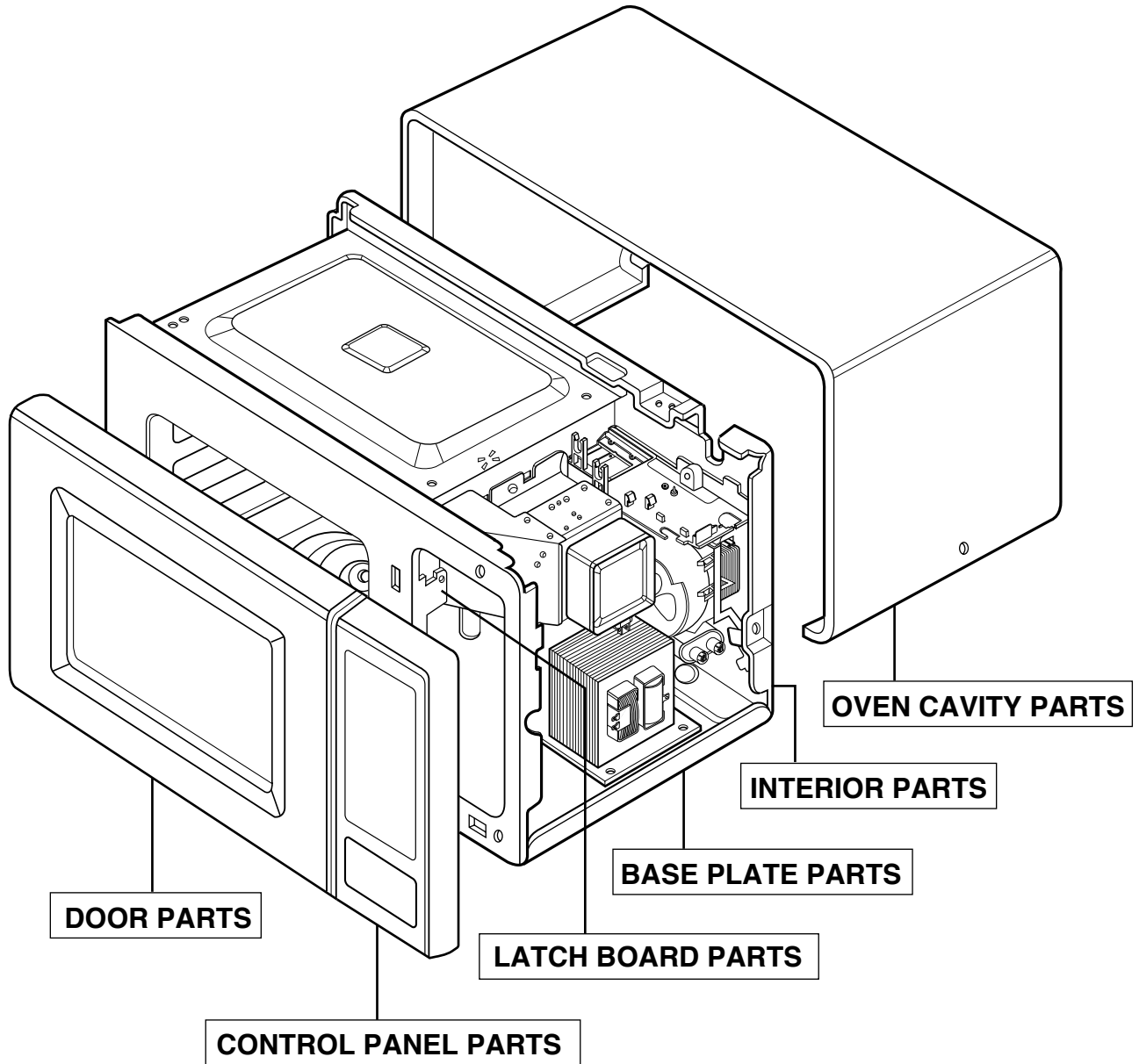

DOOR PARTS

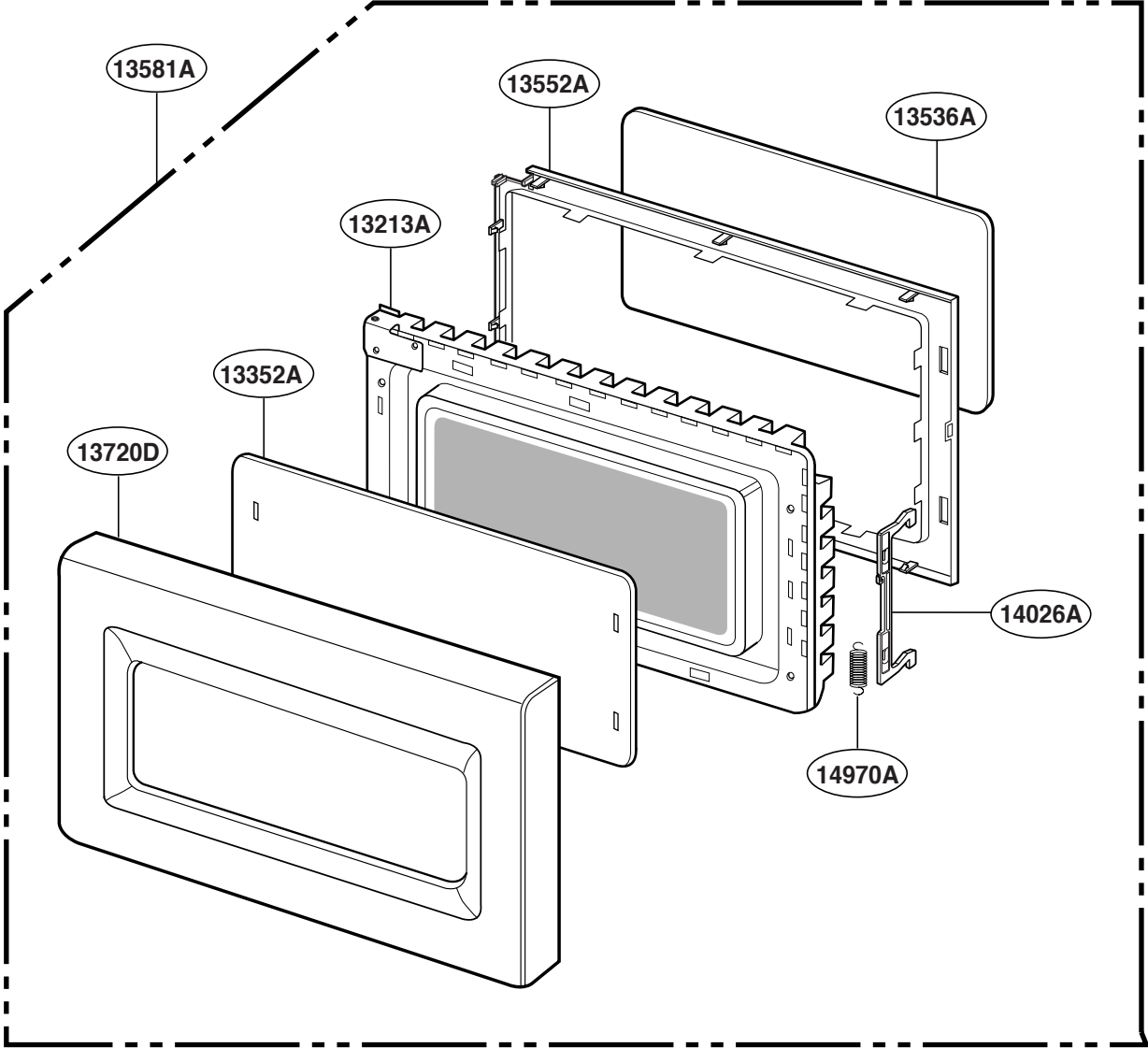

CONTROLLER PARTS

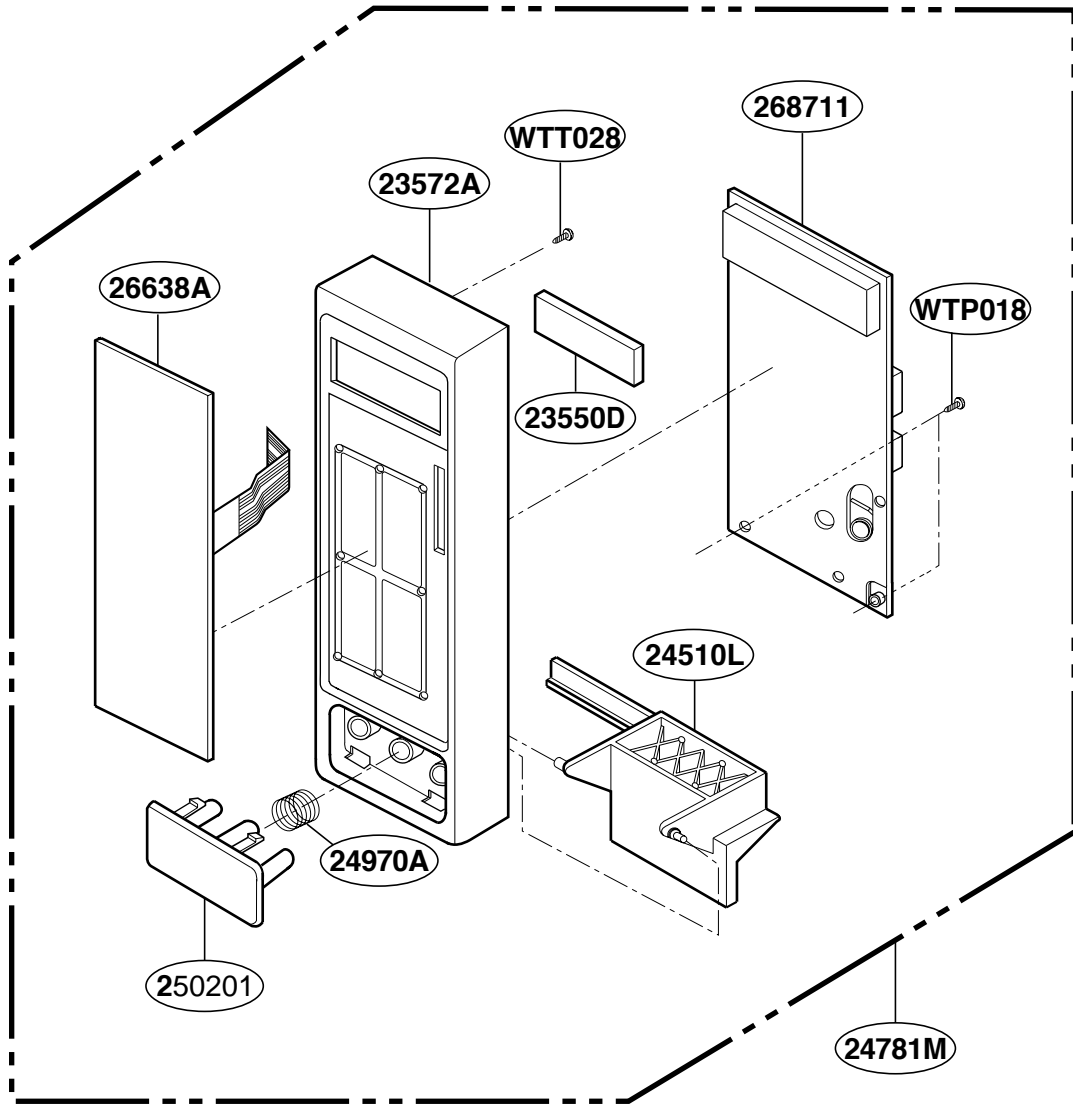

OVEN CAVITY PARTS

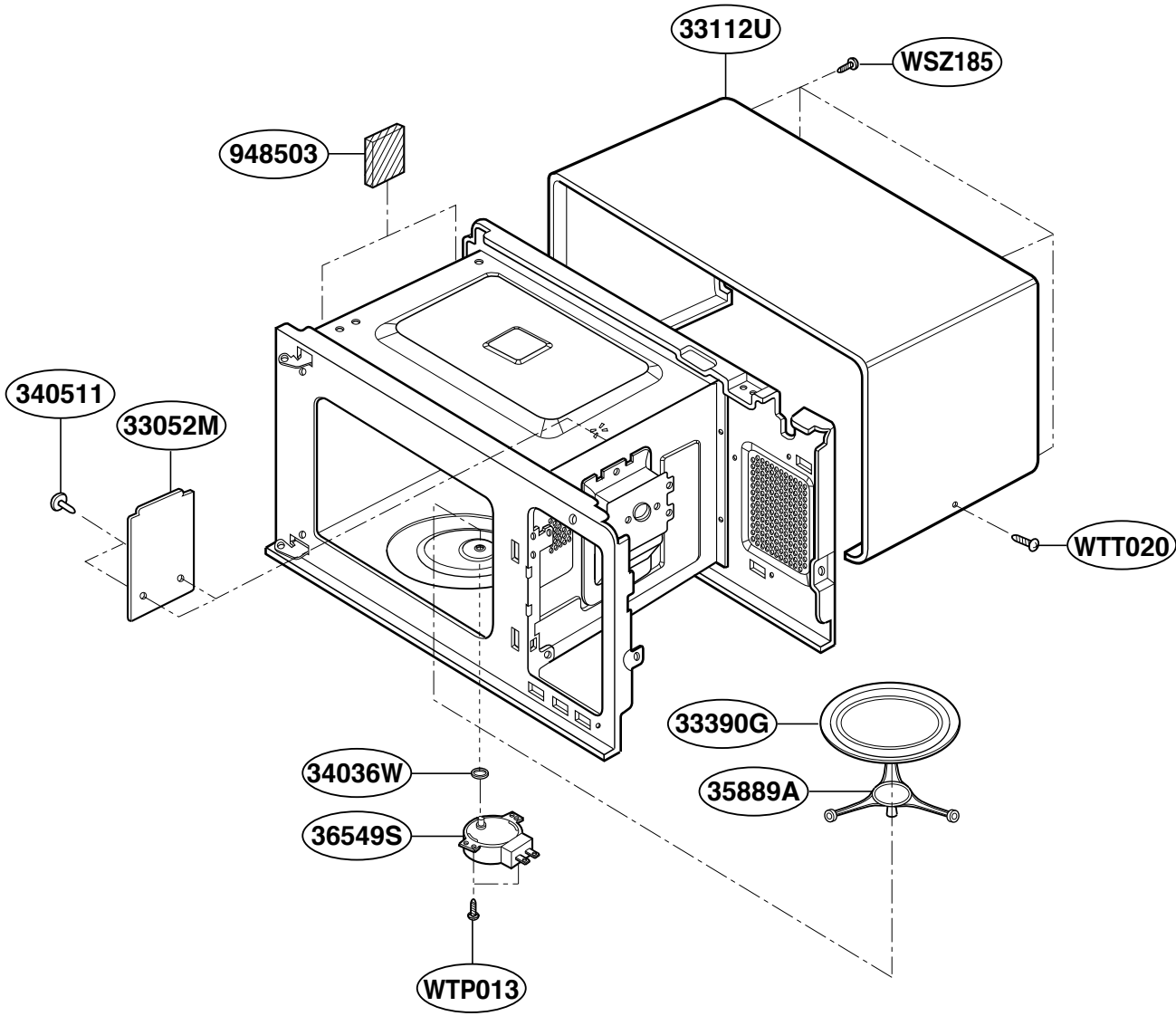

LATCH BOARD PARTS

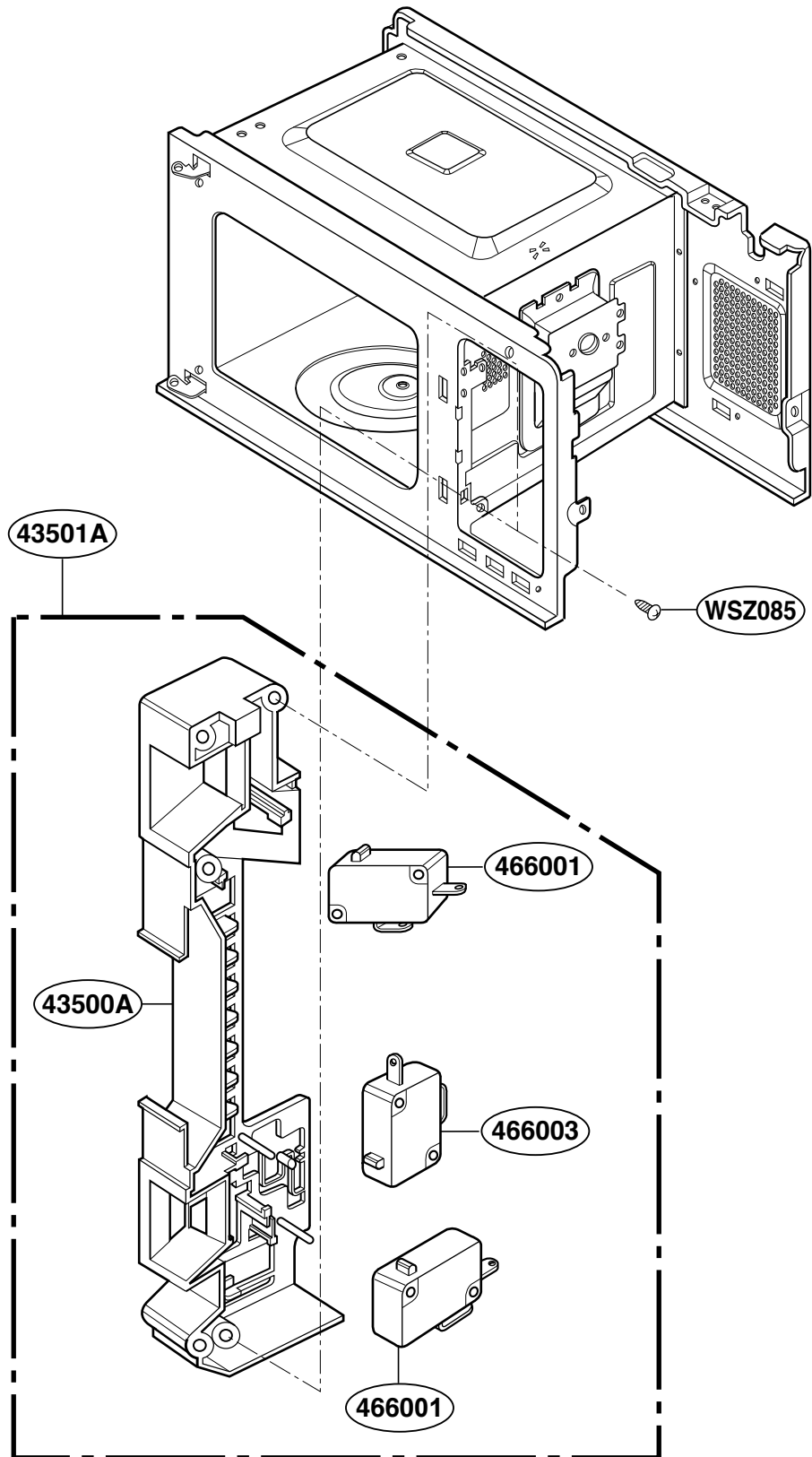

INTERIOR PARTS

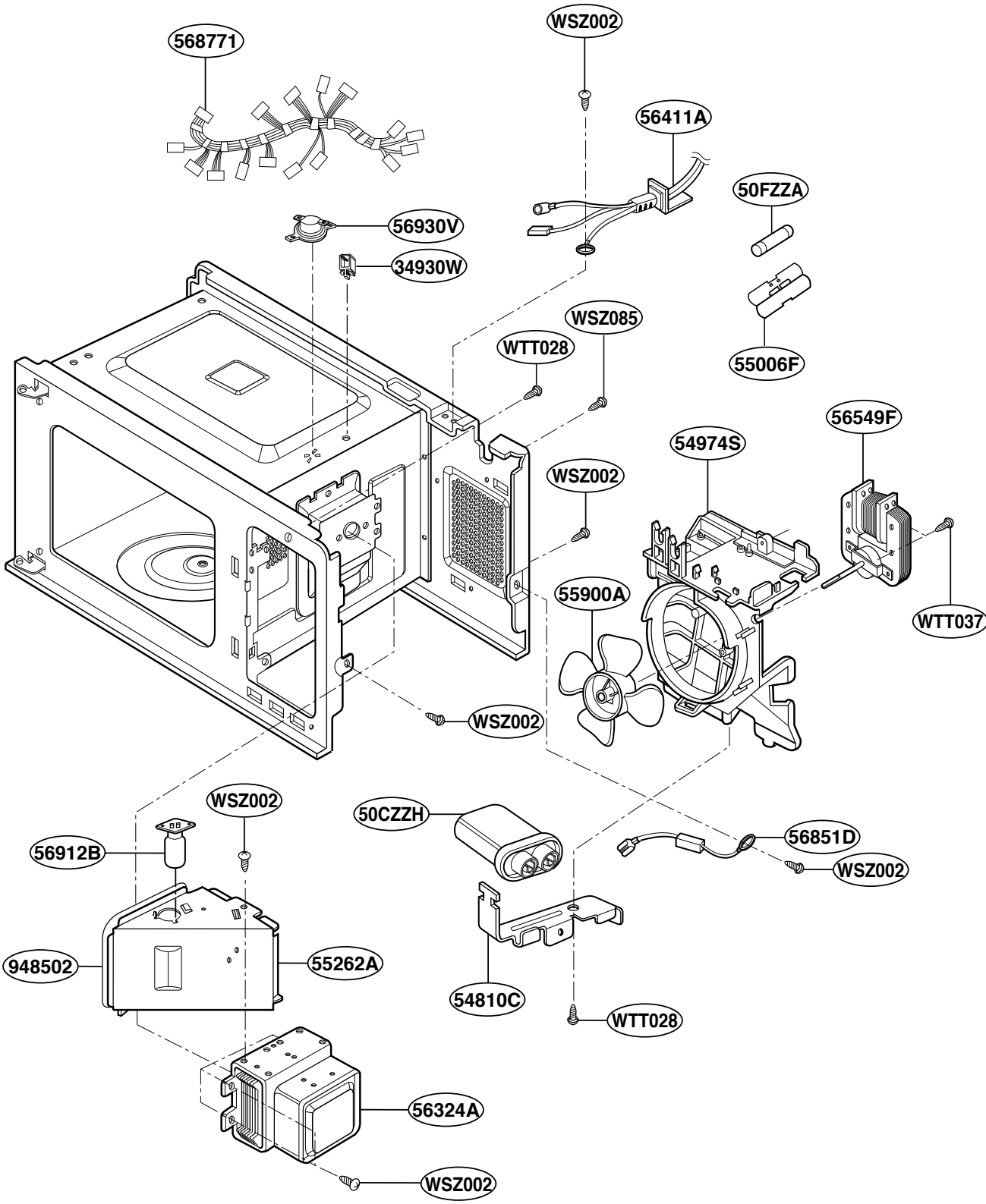

BASE PLATE PARTS

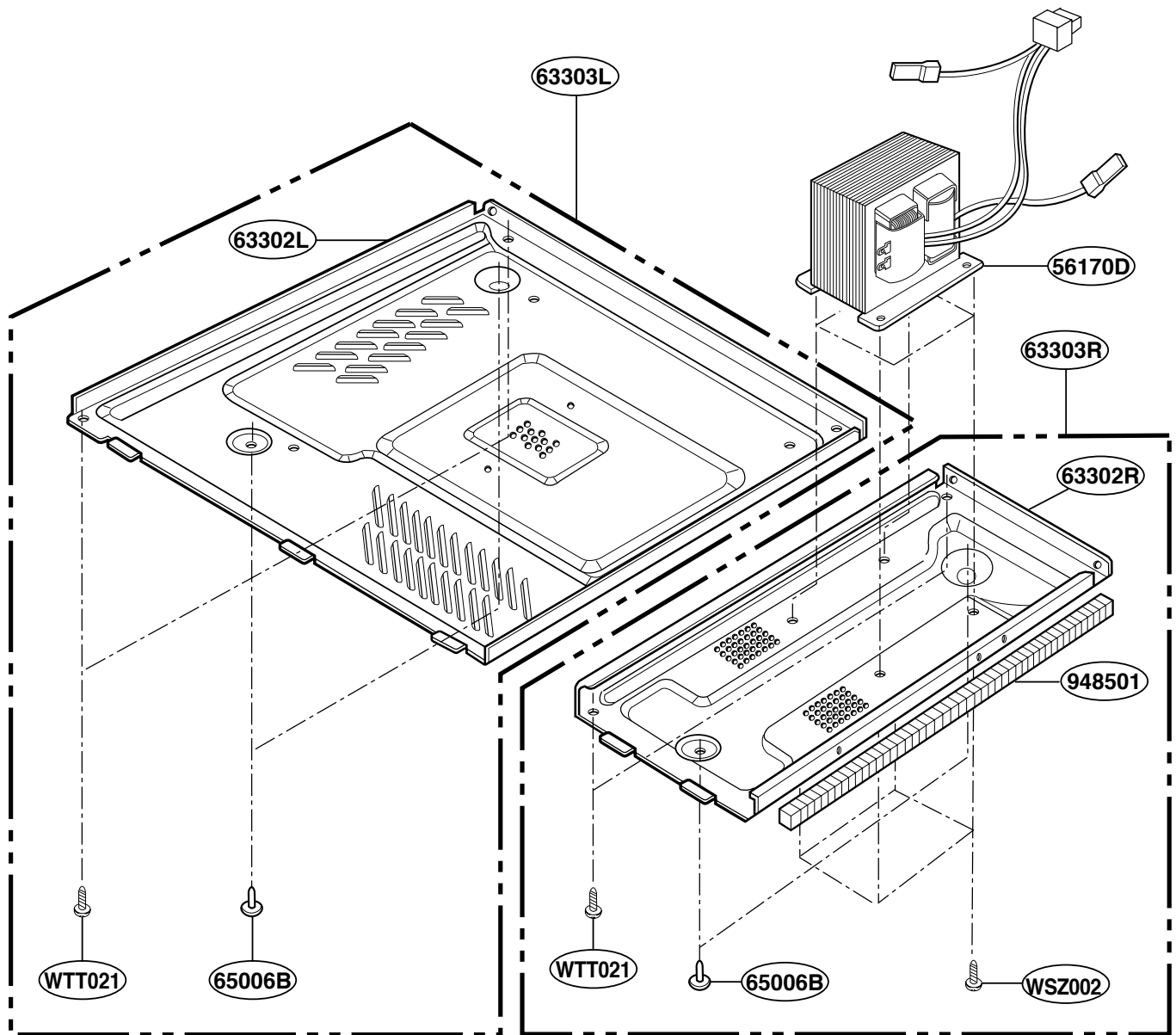

SCHEMATIC DIAGRAM OF P.C.B.

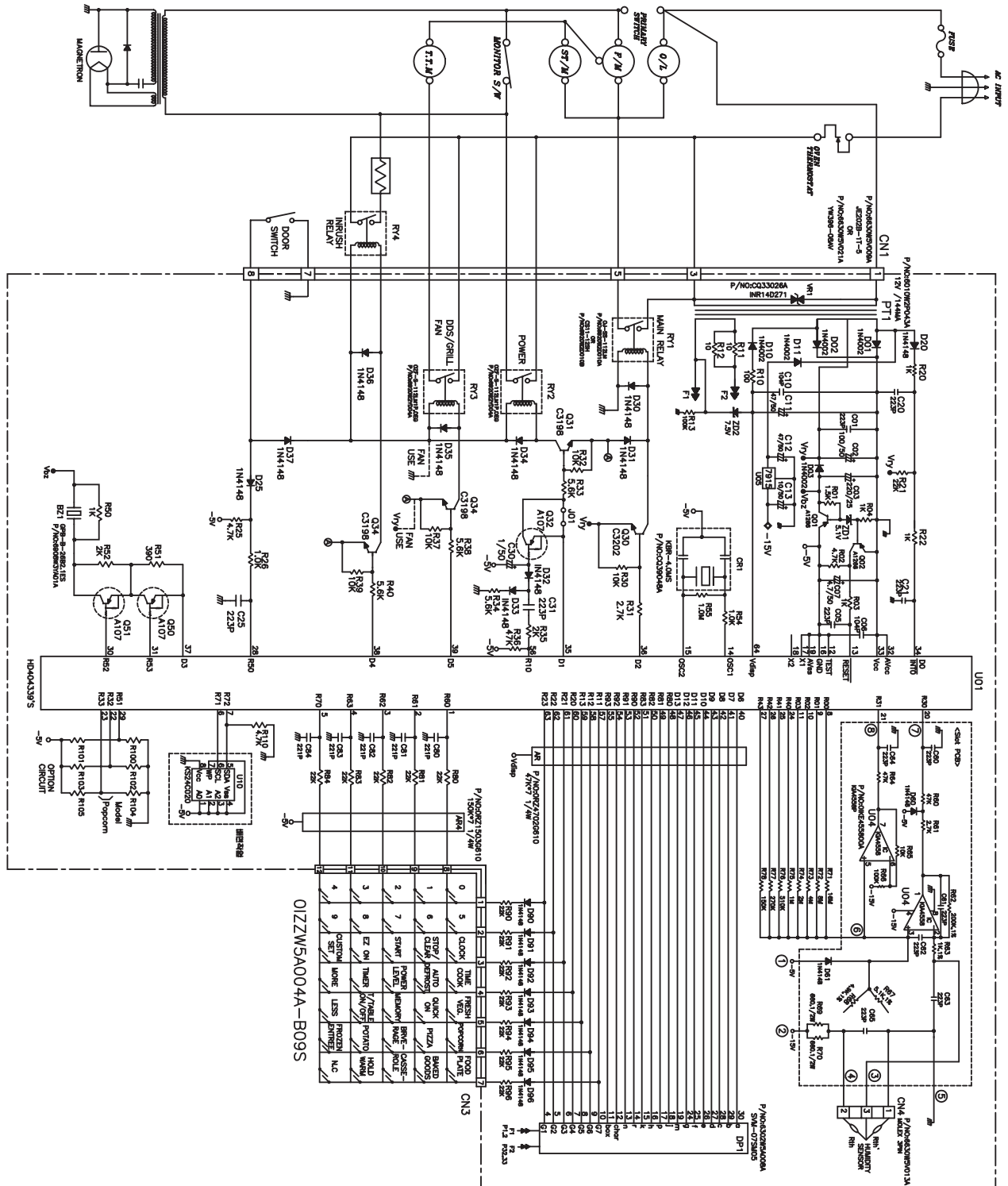

PRINTED CIRCUIT BOARD

