



# 16-Bit Stereo DIGITAL-TO-ANALOG CONVERTER with **USB** Interface

## FEATURES

- **INTEGRATED USB INTERFACE:**
  - Full-Speed Transceiver Supports 12Mbps Data Transfer
  - Fully Compliant with the USB 1.0 Specification
  - Adaptive Mode for Isochronous Transfer
  - Self-Powered Device
- **ACCEPTS 16-BIT STEREO AND MONO USB AUDIO DATA STREAMS**
- **ANALOG PERFORMANCE ( $V_{CC} = 5V$ ):**
  - Dynamic Range: 100dB (typ at 16-bit)
  - SNR: 105dB (typ)
  - THD+N: 0.002% (typ at 16-bit)
  - Full-Scale Output: 3.1V<sub>PP</sub>
- **8X OVERSAMPLING DIGITAL FILTER:**
  - Passband: 0.454f<sub>S</sub>
  - Stopband: 0.546f<sub>S</sub>
  - Passband Ripple: ±0.002dB
  - Stopband Attenuation: –82dB
- **SAMPLING RATE (F<sub>S</sub>): 32kHz, 44.1kHz, 48kHz**
- **ON-CHIP CLOCK GENERATOR WITH SINGLE 12MHz CLOCK SOURCE**
- **MULTI-FUNCTIONS:**
  - Digital Attenuator: 0dB to –64dB, 1dB/step
  - Soft Mute
  - Zero Flag
  - Suspend Flag
  - Playback Flag
- **DUAL POWER SUPPLIES:**
  - +5V for Analog Portion
  - +3.3V for Digital Portion
- **PACKAGE: SSOP-28**

## APPLICATIONS

- **STAND-ALONE USB AUDIO SPEAKERS**
- **CRT/LCD INTEGRATED USB AUDIO SPEAKERS**
- **USB AUDIO AMPLIFIERS**
- **OTHER USB AUDIO APPLICATIONS**

## DESCRIPTION

The PCM2702 is a single chip digital-to-analog converter offering two D/A output channels and an integrated USB 1.0 compliant interface controller. The newly developed SpAct™ (Sampling Period Adaptive Controlled Tracking) system recovers a stable, low-jitter clock for internal PLL and DAC operation from the USB interface audio data.

The PCM2702 is based upon Texas Instruments Enhanced Multi-level Delta-Sigma Modulator, an 8x oversampling digital interpolation filter, and an analog output low-pass filter.

The PCM2702 can accept a 48kHz, 44.1kHz and 32kHz sampling rates, using either 16-bit stereo or monaural audio data. Digital attenuation and soft-mute features are included, and are controlled via USB audio class request.

Patents Pending.

SpAct™ is a trademark of Texas Instruments.



Please be aware that an important notice concerning availability, standard warranty, and use in critical applications of Texas Instruments semiconductor products and disclaimers thereto appears at the end of this data sheet.

All trademarks are the property of their respective owners.

## ABSOLUTE MAXIMUM RATINGS<sup>(1)</sup>

Supply Voltage <sup>(2)</sup> .....	+6.5V
Supply Voltage <sup>(3)</sup> .....	+4.0V
Supply Voltage Differences <sup>(4)</sup> .....	±0.1V
Supply Voltage Differences <sup>(5)</sup> .....	±0.1V
Ground Voltage Differences <sup>(6)</sup> .....	±0.1V
Digital Input Voltage <sup>(7)</sup> .....	-0.3V to $V_{DD} + 0.3V$
Digital Input Voltage <sup>(8)</sup> .....	-0.3V to 6.5V
Analog Input Voltage .....	-0.3V to $V_{CC} + 0.3V$
Input Current (any pins except supplies) .....	±10mA
Operating Temperature .....	-25°C to +85°C
Storage Temperature .....	-55°C to +125°C
Junction Temperature .....	+150°C
Lead Temperature (soldering, 5s) .....	+260°C
Package Temperature (IR reflow, peak, 10s) .....	+235°C

NOTES: (1) Stresses above those listed under Absolute Maximum Ratings may cause permanent damage to the device. Exposure to absolute maximum conditions for extended periods may affect device reliability. (2)  $V_{CC}$ ,  $V_{CCL}$ ,  $V_{CCR}$ ,  $V_{DDP}$ . (3)  $V_{DD}$ ,  $V_{DDC}$ . (4) Among  $V_{CC}$ ,  $V_{CCL}$ ,  $V_{CCR}$ ,  $V_{CCP}$ . (5) Among  $V_{DD}$ ,  $V_{DDC}$ . (6) Among AGND, AGNDL, AGNDR, AGNDP, DGND, DGNDL, and DGNDU. (7) XT1, D+, D-, PLYBCK, SSPND, ZERO, XTO. (8)  $V_{BUS}$ , TEST#, TEST2, TEST1, TEST0.

## ELECTROSTATIC DISCHARGE SENSITIVITY

This integrated circuit can be damaged by ESD. Texas Instruments recommends that all integrated circuits be handled with appropriate precautions. Failure to observe proper handling and installation procedures can cause damage.

ESD damage can range from subtle performance degradation to complete device failure. Precision integrated circuits may be more susceptible to damage because very small parametric changes could cause the device not to meet its published specifications.

## PACKAGE/ORDERING INFORMATION<sup>(1)</sup>

PRODUCT	PACKAGE-LEAD	PACKAGE DESIGNATOR	SPECIFIED TEMPERATURE RANGE	PACKAGE MARKING	ORDERING NUMBER	TRANSPORT MEDIA
PCM2702E	SSOP-28	DB	0°C to +70°C	PCM2702E	PCM2702E	Rails
"	"	"	"	"	PCM2702E/2K	Tape and Reel

NOTE: (1) For the most current package and ordering information, see the Package Option Addendum at the end of this document, or see the TI website at [www.ti.com](http://www.ti.com).

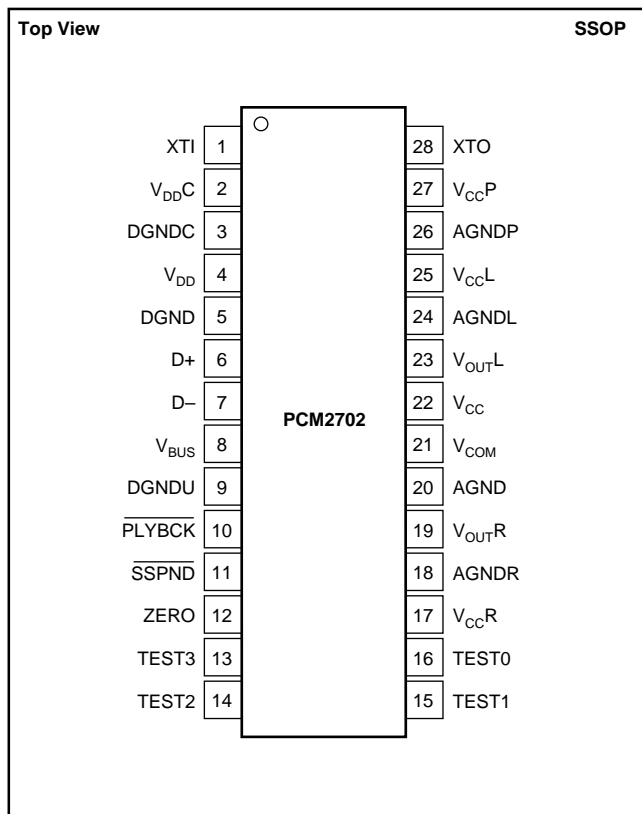

PIN	NAME	TYPE	DESCRIPTIONS
1	XT1	IN	Crystal Oscillator Input. <sup>(1)</sup>
2	$V_{DDC}$	—	Digital Power Supply for Clock Generator, +3.3V.
3	DGND	—	Digital Ground for Clock Generator.
4	$V_{DD}$	—	Digital Power Supply, +3.3V.
5	DGND	—	Digital Ground.
6	D+	IN/OUT	USB Differential Input/Output Plus.
7	D-	IN/OUT	USB Differential Input/Output Minus.
8	$V_{BUS}$	IN	USB Bus Power (this pin NEVER consumes USB bus power). <sup>(2)</sup>
9	DGNDU	—	Digital Ground for USB Transceiver.
10	PLYBCK	OUT	Playback flag, active LOW (LOW: playback, HIGH: idle).
11	SSPND	OUT	Suspend flag, active LOW (LOW: suspend, HIGH: operational).
12	ZERO	OUT	Zero flag (LOW: Normal, HIGH: ZERO.)
13	TEST3	IN	Test pin 3. Connect to digital ground. <sup>(2)</sup>
14	TEST2	IN	Test pin 2. Connect to digital ground. <sup>(2)</sup>
15	TEST1	IN	Test pin 1. Connect to digital ground. <sup>(2)</sup>
16	TEST0	IN	Test pin 0. Connect to digital ground. <sup>(2)</sup>
17	$V_{CCR}$	—	Analog Supply for R-channel, +5V.
18	AGNDR	—	Analog Ground for R-channel.
19	$V_{OUTR}$	OUT	Analog Output for R-channel.
20	AGND	—	Analog Ground.
21	$V_{COM}$	—	DC Common-Mode Voltage for DAC.
22	$V_{CC}$	—	Analog Supply, +5V.
23	$V_{OUTL}$	OUT	Analog Output for L-channel.
24	AGNDL	—	Analog Ground for L-channel.
25	$V_{CCL}$	—	Analog Supply for L-channel, +5V.
26	AGNDP	—	Analog Ground for PLL.
27	$V_{CCP}$	—	Analog Supply for PLL, +5V.
28	XTO	OUT	Crystal Oscillator Output.

NOTES: (1) 3.3 V tolerant. (2) Schmitt trigger input with internal pull-down, 5V tolerant.



# BLOCK DIAGRAM

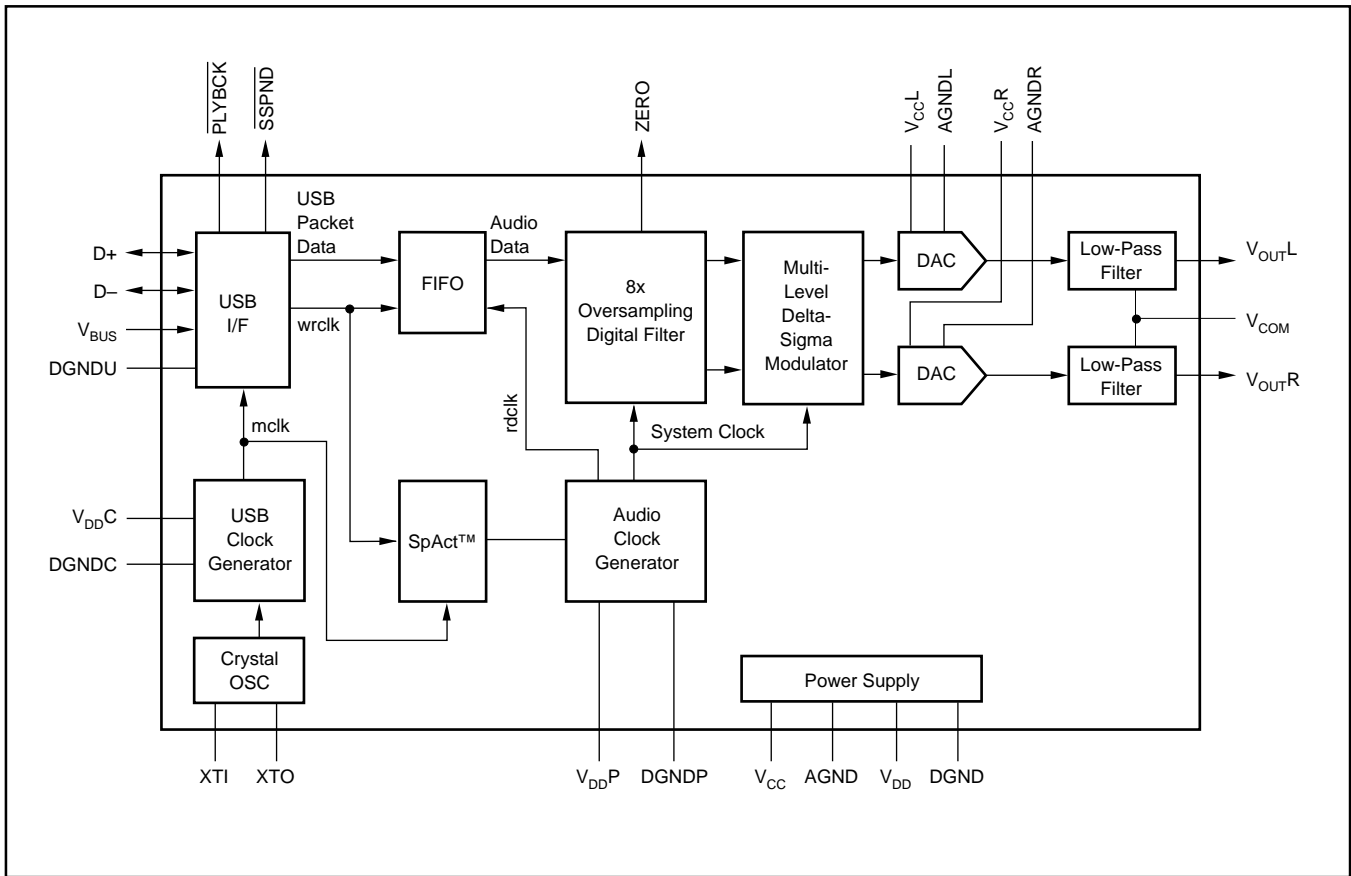

# TYPICAL CHARACTERISTICS

All specifications at  $T_A = +25^\circ\text{C}$ ,  $V_{CC} = V_{CCL} = V_{CCR} = V_{CCP} = 5.0\text{V}$ ,  $V_{DD} = V_{DDC} = 3.3\text{V}$ ,  $f_S = 44.1\text{MHz}$ , signal frequency = 1kHz and 16-bit data, unless otherwise specified.

## DIGITAL FILTER PERFORMANCE

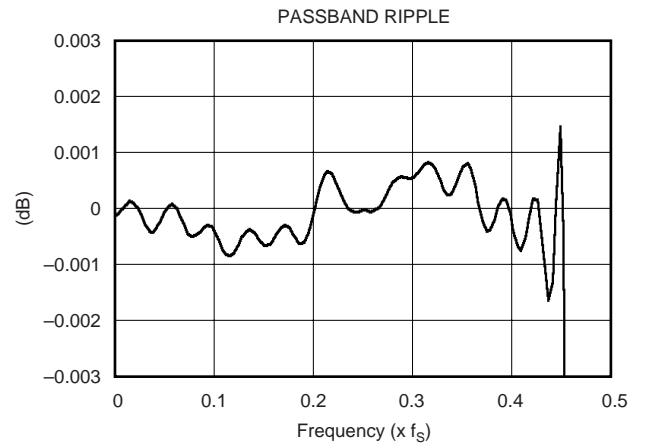
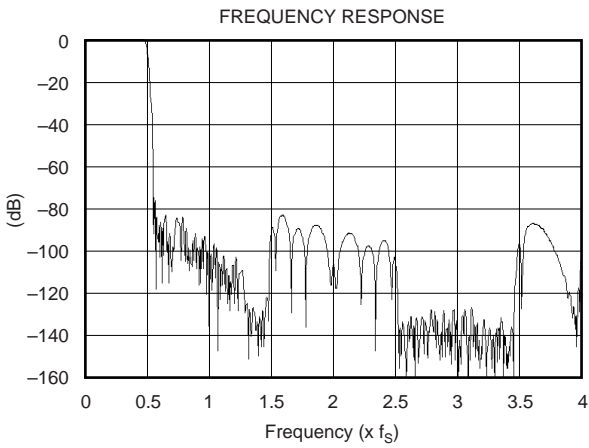

## ANALOG FILTER PERFORMANCE

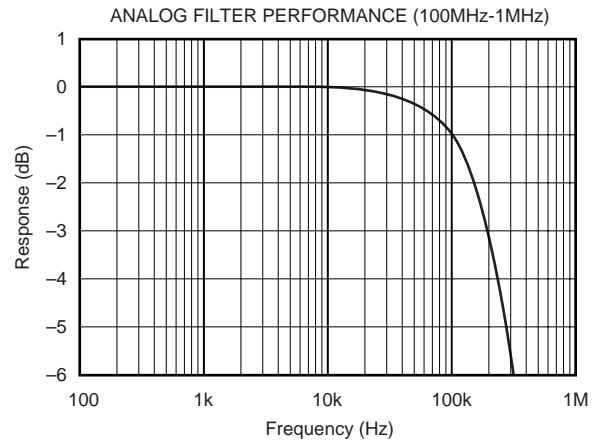
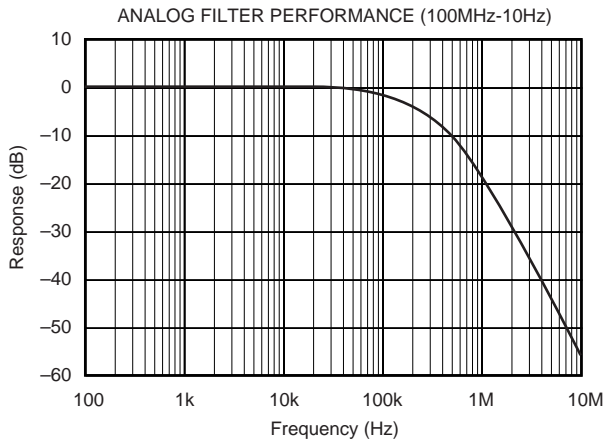

# TYPICAL CHARACTERISTICS (Cont.)

All specifications at  $T_A = +25^\circ\text{C}$ ,  $V_{CC} = V_{CCL} = V_{CCR} = V_{CCP} = 5.0\text{V}$ ,  $V_{DD} = V_{DDC} = 3.3\text{V}$ ,  $f_s = 44.1\text{kHz}$ , signal frequency = 1kHz and 16-bit data, unless otherwise specified.

## ANALOG DYNAMIC PERFORMANCE

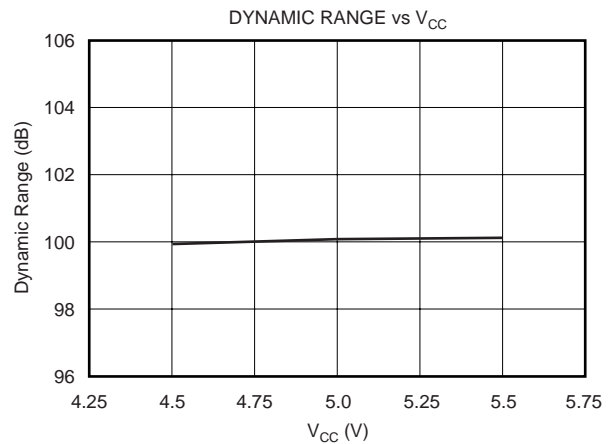
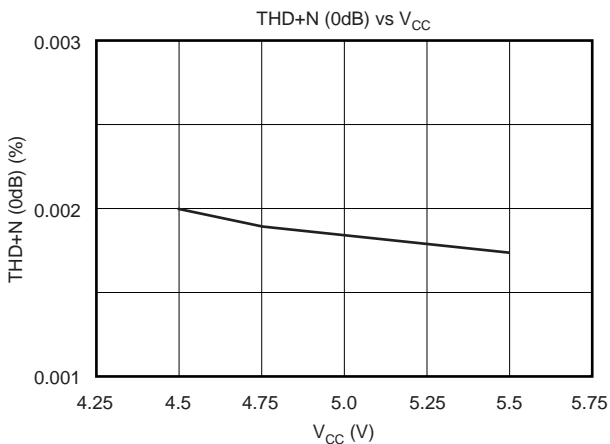
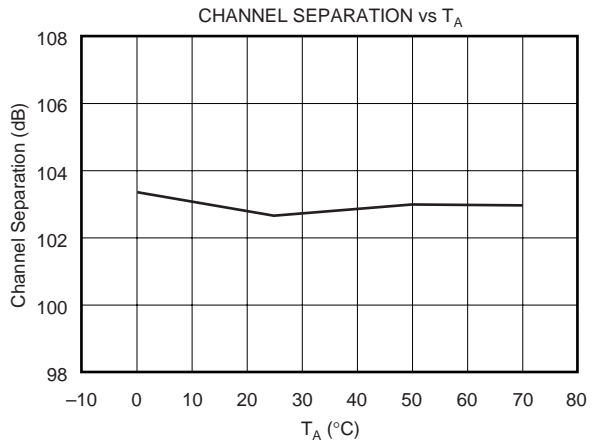
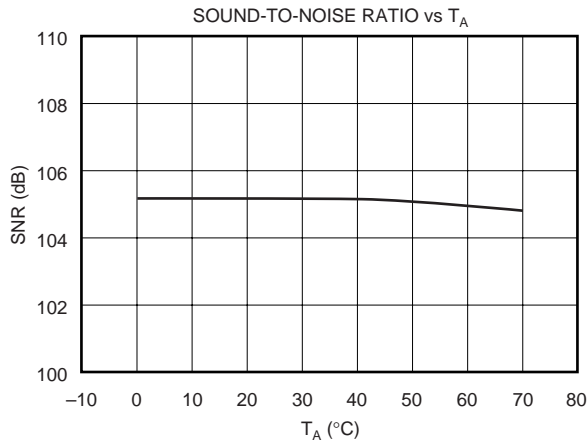
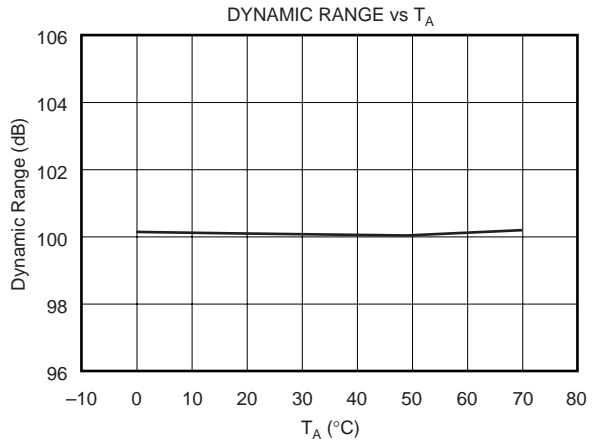
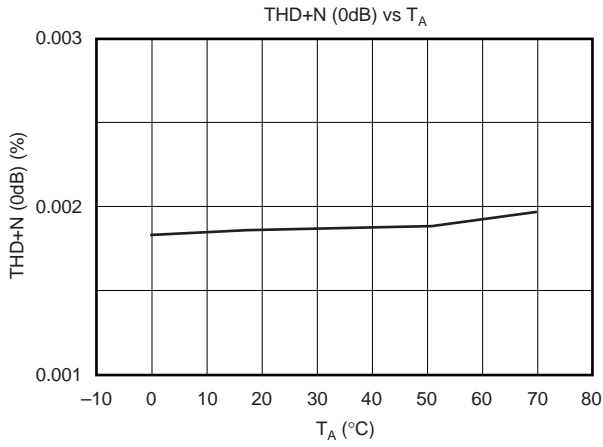

# TYPICAL CHARACTERISTICS (Cont.)

All specifications at  $T_A = +25^\circ\text{C}$ ,  $V_{CC} = V_{CCL} = V_{CCR} = V_{CCP} = 5.0\text{V}$ ,  $V_{DD} = V_{DDC} = 3.3\text{V}$ ,  $f_s = 44.1\text{MHz}$ , signal frequency = 1kHz and 16-bit data, unless otherwise specified.

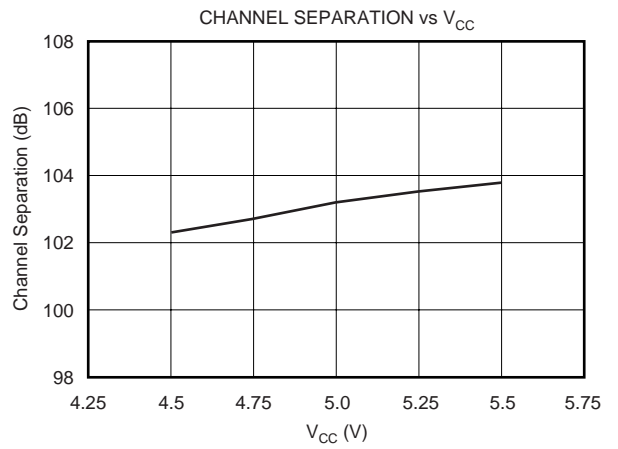
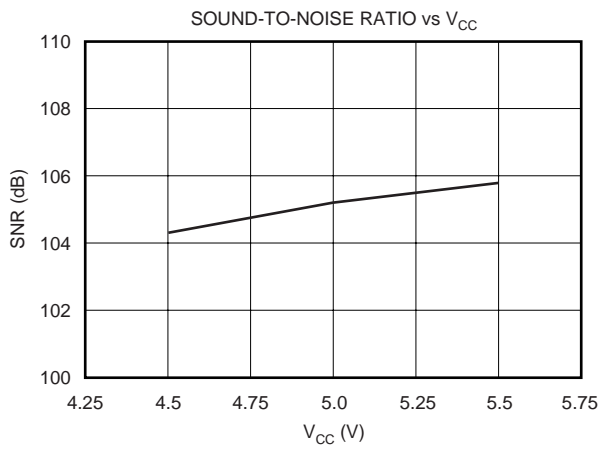

# THEORY OF OPERATION

## USB INTERFACE

The description of the USB interface complies with Universal Serial Bus specification Rev. 1.0.

Control and audio data are both transferred to the PCM2702 via D+ (pin 6) and D- (pin 7). All data to/from the PCM2702 are transferred at full-speed.  $V_{BUS}$  (pin 8) and DGNDU (pin 9) are also connected to the USB bus.  $V_{BUS}$  (pin 8) never consumes USB bus power, it is used only for detecting the connection of the USB bus. The following information is provided in the device descriptor.

USB Revision	1.0
Device Class	0x00 (device defined interface level)
Device Subclass	0x00 (not specified)
Device Protocol	0x00 (not specified)
Max Packet Size for Endpoint 0	8 byte
Vendor ID	0x08BB
Device ID	0x2702
Release	1.0

TABLE I. Device Definition.

## DEVICE CONFIGURATION

Figure 1 illustrates USB audio function topology. The PCM2702 has two interfaces. Each interface is constructed by some alternative setting. Interface #0 has one alternative setting. Alternative setting #0 describes the standard audio control interface. The audio control interface is constructed by a terminal. The PCM2702 has the following three terminals.

- Input Terminal (IT)
- Output Terminal (OT)
- Feature Unit (FU)

The Input Terminal is defined as “USB stream” (terminal type 0x0101). The Input Terminal can accept 2-channel audio streams comprised of left and right channel data. The Output Terminal is defined as a “speaker” (terminal type 0x0301). The Feature Unit supports the following sound control features.

- Volume Control
- Mute Control

The built-in digital volume controller can be manipulated by an audio class specific request from 0.0dB to -64.0dB in steps of 1.0dB. Each channel can be set independently. The master volume control is also supported. The built-in digital mute controller can be manipulated by an audio class specific request. A master mute-control request is acceptable. A request to an individual channel will be stalled and ignored.

Interface #1 has three alternative settings. Alternative setting #0 is the Zero Bandwidth setting. Alternative setting #1 is the 16-Bit Stereo setting, and is an operational setting. Alternative setting #2 is the 16-Bit Monaural setting, and is also an operational setting. The PCM2702 has the following two endpoints.

- Control Endpoint (EP #0)
- Isochronous Audio Data Stream Endpoint (EP #2)

The Control Endpoint is a default endpoint and is used to control all functions of the PCM2702 by the standard USB request and the USB audio class specific request. The Isochronous Audio Data Stream Endpoint is an audio sink endpoint, which receives the PCM audio data, and accepts the adaptive transfer mode.

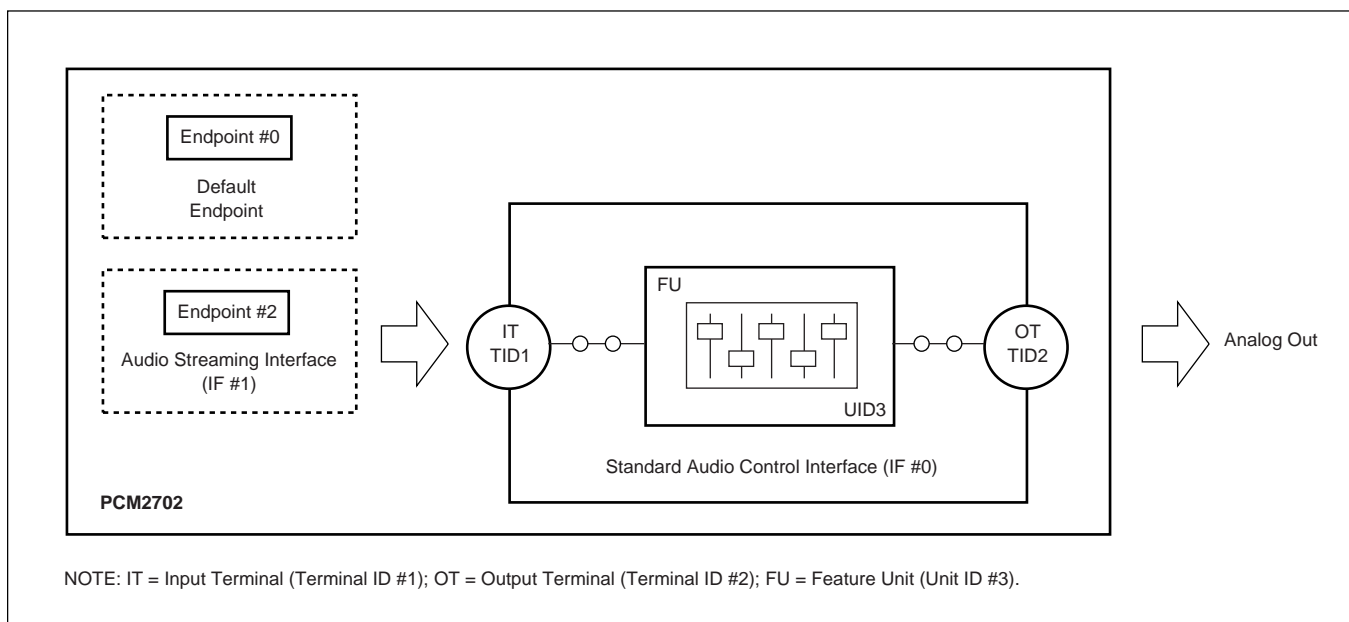



## CLOCK AND RESET

The PCM2702 requires a 12MHz ( $\pm 500$ ppm) clock for USB and audio functions, which may be generated by an on-chip crystal oscillator with external 12MHz crystal resonator, or supplied by an external clock applied at XTI (pin1). The 12MHz crystal resonator must be connected to XTI (pin 1) and XTO (pin 28), along with a 1M $\Omega$  resistor and two small capacitors (value is dependent upon the specified load capacitance of the crystal resonator). If an external clock is used, the clock must be supplied at XTI, and XTO must be left open. The clock signal applied at XTI must be +3.3V logic level, as this input is not +5V tolerant. Figures 2 and 3 illustrate the circuit connections required for crystal and external clock options.

The PCM2702 includes an internal power-on reset circuit, which automatically initializes digital logic when  $V_{DD}$  exceeds 2.0V typical (range: 1.6V to 2.4V). Initialization requires approximately 350 $\mu$ s for completion. The  $V_{DD}$

supply must rise to 2.0V within 10ms for proper power-on sequence operation.

## INTERFACE SEQUENCE

### Power-on, Attach, and Playback Sequence

The PCM2702 is ready for setup when the reset sequence has finished and the USB bus is connected. After connection is established, the PCM2702 is ready to accept USB audio data. While waiting for audio data (idle state), the analog outputs are set to bipolar zero (BPZ) and the zero flag, ZERO (pin 12), is set to HIGH.

When receiving the audio data, the PCM2702 stores the first audio packet, which contains 1ms of audio data, into an internal storage buffer. The PCM2702 starts playing the audio data upon detection of the Start of Frame (SOF) packet.

See Figures 4 and 5 for the normal operation sequence.

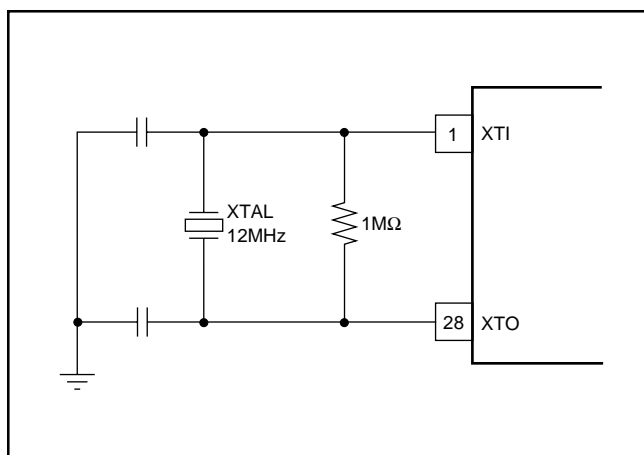

FIGURE 2. 12MHz Crystal Resonator Connection.

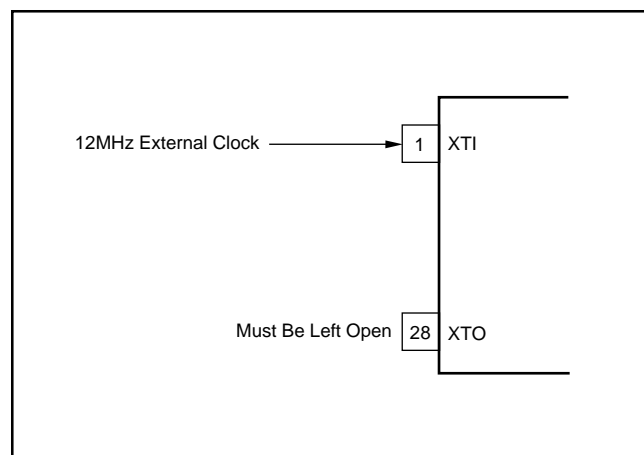

FIGURE 3. External 12MHz Clock Input Connection.

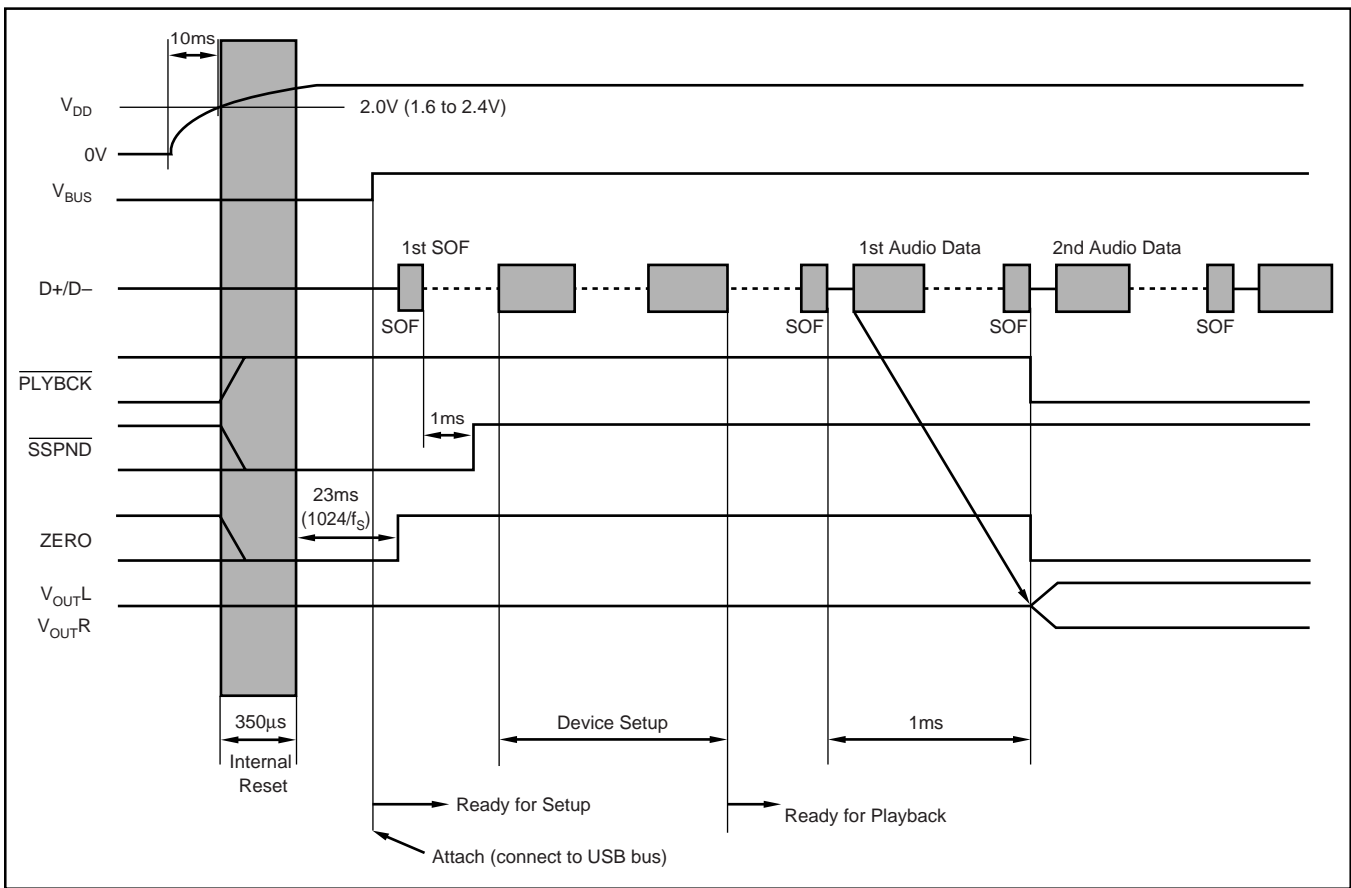

FIGURE 4. Connecting the PCM2702 to the USB Bus After Power-On.

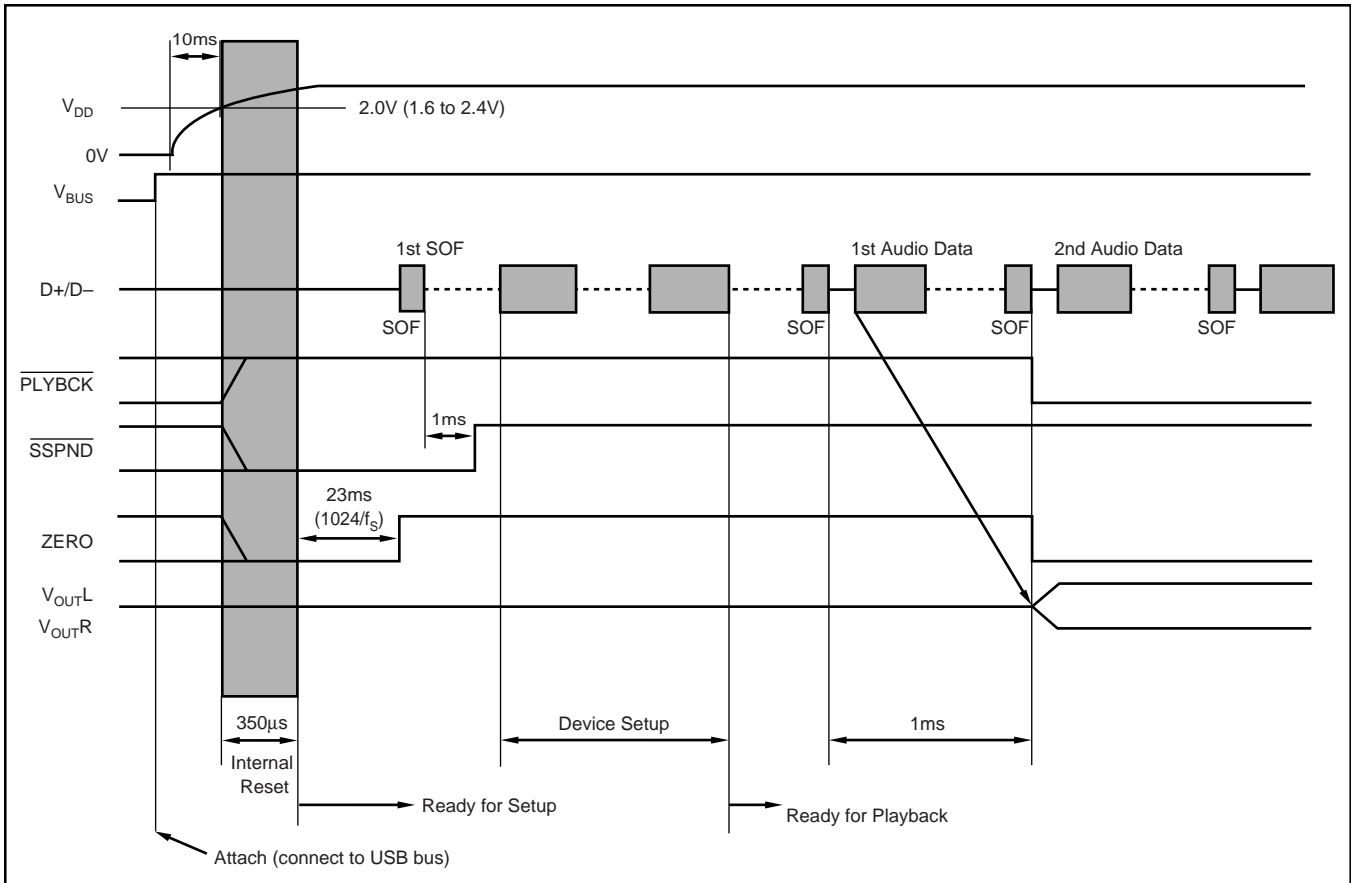

FIGURE 5. Connecting the PCM2702 to the USB Bus Prior to Power-On.

## Play, Stop, and Detach sequence

When host finishes or aborts audio playback, the PCM2702 will stop playing after the last transmitted audio data has been received. Figure 6 shows the operation sequence for play, stop, and detach.

## PLYBCK, SSPND, AND ZERO FLAG

PLYBCK, SSPND, and Zero flag in Figures 4, 5, and 6 are defined as follows.

**PLYBCK**—while PCM audio input data is playing back, PLYBCK (pin 10) is switched LOW.

**SSPND**—upon detection of a suspend state on the USB port, SSPND (pin 11) is switched LOW.

**ZERO**—if the PCM audio input data is continuously zero for 1024 sampling periods ( $1/f_s$ ), ZERO (pin12) is switched to HIGH.

## TEST PINS

The PCM2702 has four test pins—TEST0 (pin 16), TEST1 (pin 15), TEST2 (pin 14), and TEST3 (pin 13)—which are used solely for testing at the factory. These pins must be connected to a digital ground for proper operation.

## OPERATING ENVIRONMENT INFORMATION

For information about the PC operating environment for the PCM2702, see Application Report SLAA374, *Updated Operating Environments for PCM270x, PCM290x Applications*, available for download at [www.ti.com](http://www.ti.com).

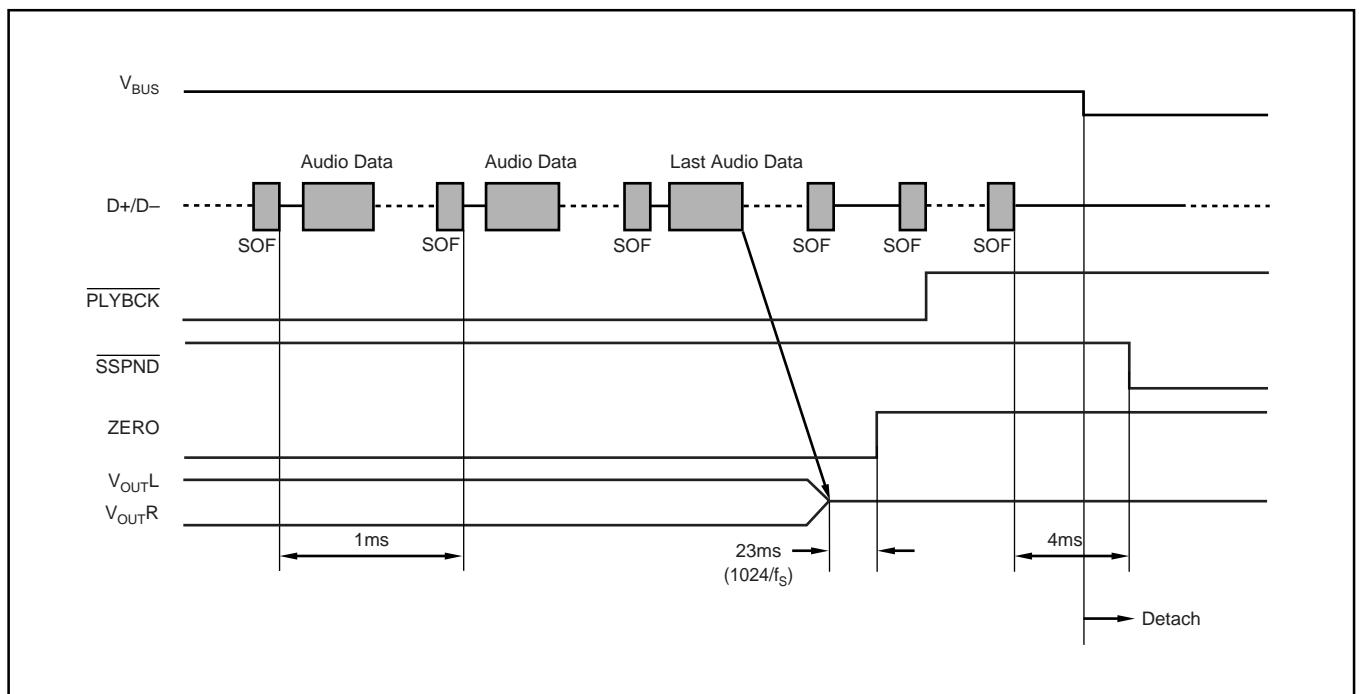

FIGURE 6. Play, Stop, and Detach.

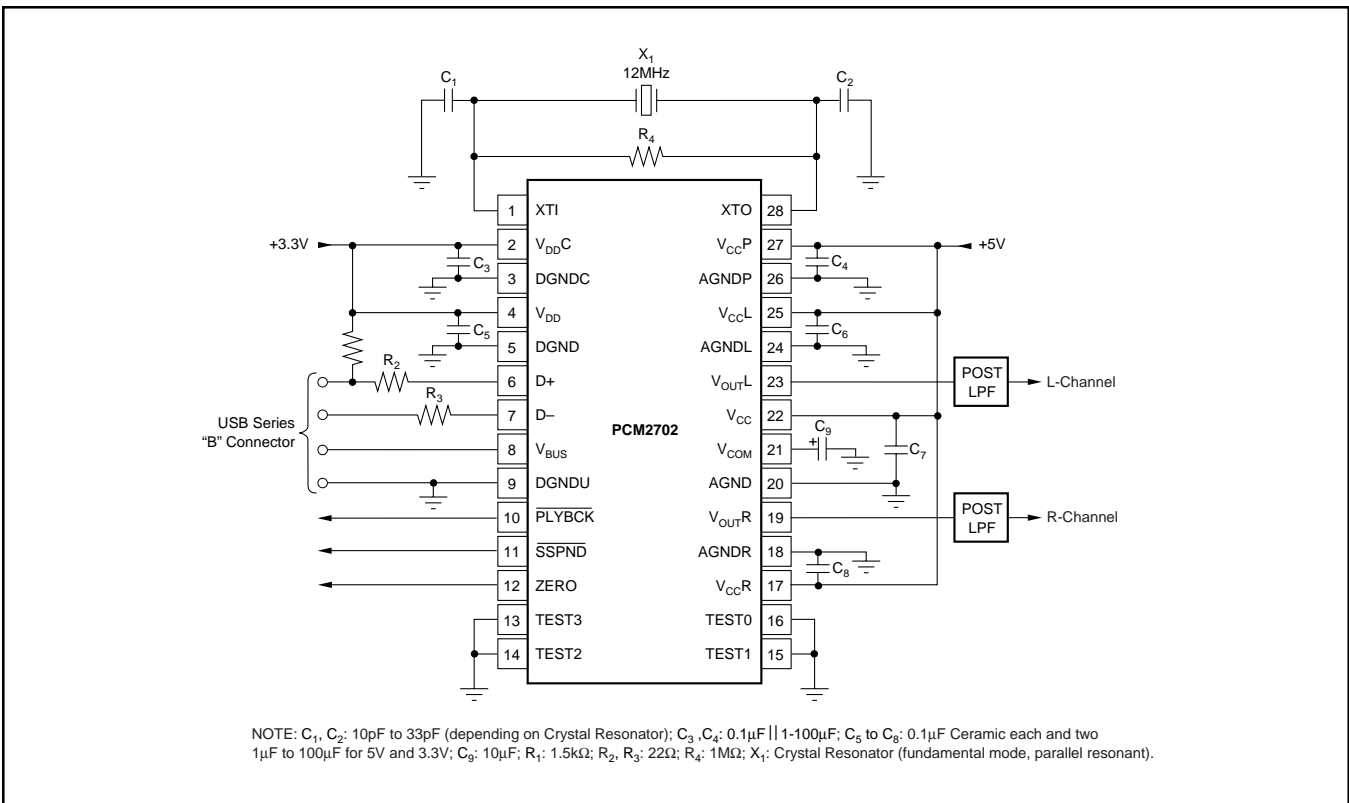

FIGURE 7. Typical Connection Diagram.

### Revision History

DATE	REVISION	PAGE	SECTION	DESCRIPTION
11/07	A	—	—	Updated front page format.
		11	Operating Environment	Added section and reference to SLAA374.

NOTE: Page numbers for previous revisions may differ from page numbers in the current version.

**PACKAGING INFORMATION**

Orderable Device	Status <sup>(1)</sup>	Package Type	Package Drawing	Pins	Package Qty	Eco Plan <sup>(2)</sup>	Lead/Ball Finish	MSL Peak Temp <sup>(3)</sup>
PCM2702E	ACTIVE	SSOP	DB	28	47	Green (RoHS & no Sb/Br)	CU NIPDAU	Level-1-260C-UNLIM
PCM2702E/2K	ACTIVE	SSOP	DB	28	2000	Green (RoHS & no Sb/Br)	CU NIPDAU	Level-1-260C-UNLIM
PCM2702E/2KG4	ACTIVE	SSOP	DB	28	2000	Green (RoHS & no Sb/Br)	CU NIPDAU	Level-1-260C-UNLIM
PCM2702EG/2KE6	ACTIVE	SSOP	DB	28		TBD	Call TI	Call TI
PCM2702EG4	ACTIVE	SSOP	DB	28	47	Green (RoHS & no Sb/Br)	CU NIPDAU	Level-1-260C-UNLIM

<sup>(1)</sup> The marketing status values are defined as follows:

**ACTIVE:** Product device recommended for new designs.

**LIFEBUY:** TI has announced that the device will be discontinued, and a lifetime-buy period is in effect.

**NRND:** Not recommended for new designs. Device is in production to support existing customers, but TI does not recommend using this part in a new design.

**PREVIEW:** Device has been announced but is not in production. Samples may or may not be available.

**OBSOLETE:** TI has discontinued the production of the device.

<sup>(2)</sup> Eco Plan - The planned eco-friendly classification: Pb-Free (RoHS), Pb-Free (RoHS Exempt), or Green (RoHS & no Sb/Br) - please check <http://www.ti.com/productcontent> for the latest availability information and additional product content details.

**TBD:** The Pb-Free/Green conversion plan has not been defined.

**Pb-Free (RoHS):** TI's terms "Lead-Free" or "Pb-Free" mean semiconductor products that are compatible with the current RoHS requirements for all 6 substances, including the requirement that lead not exceed 0.1% by weight in homogeneous materials. Where designed to be soldered at high temperatures, TI Pb-Free products are suitable for use in specified lead-free processes.

**Pb-Free (RoHS Exempt):** This component has a RoHS exemption for either 1) lead-based flip-chip solder bumps used between the die and package, or 2) lead-based die adhesive used between the die and leadframe. The component is otherwise considered Pb-Free (RoHS compatible) as defined above.

**Green (RoHS & no Sb/Br):** TI defines "Green" to mean Pb-Free (RoHS compatible), and free of Bromine (Br) and Antimony (Sb) based flame retardants (Br or Sb do not exceed 0.1% by weight in homogeneous material)

<sup>(3)</sup> MSL, Peak Temp. -- The Moisture Sensitivity Level rating according to the JEDEC industry standard classifications, and peak solder temperature.

**Important Information and Disclaimer:**The information provided on this page represents TI's knowledge and belief as of the date that it is provided. TI bases its knowledge and belief on information provided by third parties, and makes no representation or warranty as to the accuracy of such information. Efforts are underway to better integrate information from third parties. TI has taken and continues to take reasonable steps to provide representative and accurate information but may not have conducted destructive testing or chemical analysis on incoming materials and chemicals. TI and TI suppliers consider certain information to be proprietary, and thus CAS numbers and other limited information may not be available for release.

In no event shall TI's liability arising out of such information exceed the total purchase price of the TI part(s) at issue in this document sold by TI to Customer on an annual basis.

**TAPE AND REEL BOX INFORMATION**

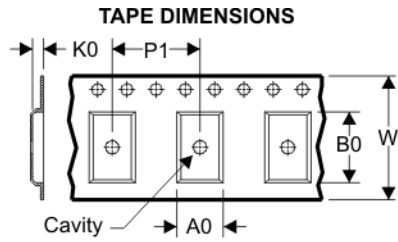
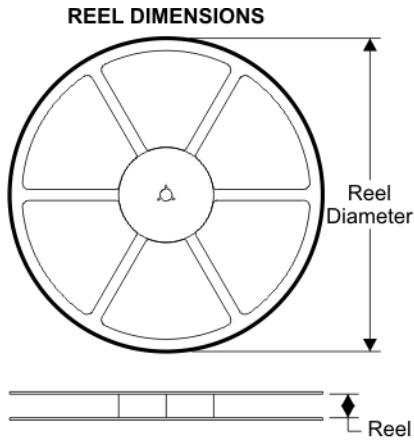

A0	Dimension designed to accommodate the component width
B0	Dimension designed to accommodate the component length
K0	Dimension designed to accommodate the component thickness
W	Overall width of the carrier tape
P1	Pitch between successive cavity centers

**QUADRANT ASSIGNMENTS FOR PIN 1 ORIENTATION IN TAPE**

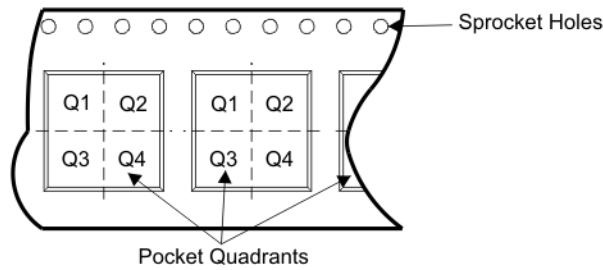

Device	Package	Pins	Site	Reel Diameter (mm)	Reel Width (mm)	A0 (mm)	B0 (mm)	K0 (mm)	P1 (mm)	W (mm)	Pin1 Quadrant
PCM2702E/2K	DB	28	SITE 49	330	17	8.5	10.8	2.4	12	16	Q1

## TAPE AND REEL BOX DIMENSIONS



Device	Package	Pins	Site	Length (mm)	Width (mm)	Height (mm)
PCM2702E/2K	DB	28	SITE 49	0.0	0.0	0.0

DB (R-PDSO-G\*\*)

PLASTIC SMALL-OUTLINE

28 PINS SHOWN



- NOTES: A. All linear dimensions are in millimeters.  
 B. This drawing is subject to change without notice.  
 C. Body dimensions do not include mold flash or protrusion not to exceed 0,15.  
 D. Falls within JEDEC MO-150



## IMPORTANT NOTICE

Texas Instruments Incorporated and its subsidiaries (TI) reserve the right to make corrections, modifications, enhancements, improvements, and other changes to its products and services at any time and to discontinue any product or service without notice. Customers should obtain the latest relevant information before placing orders and should verify that such information is current and complete. All products are sold subject to TI's terms and conditions of sale supplied at the time of order acknowledgment.

TI warrants performance of its hardware products to the specifications applicable at the time of sale in accordance with TI's standard warranty. Testing and other quality control techniques are used to the extent TI deems necessary to support this warranty. Except where mandated by government requirements, testing of all parameters of each product is not necessarily performed.

TI assumes no liability for applications assistance or customer product design. Customers are responsible for their products and applications using TI components. To minimize the risks associated with customer products and applications, customers should provide adequate design and operating safeguards.

TI does not warrant or represent that any license, either express or implied, is granted under any TI patent right, copyright, mask work right, or other TI intellectual property right relating to any combination, machine, or process in which TI products or services are used. Information published by TI regarding third-party products or services does not constitute a license from TI to use such products or services or a warranty or endorsement thereof. Use of such information may require a license from a third party under the patents or other intellectual property of the third party, or a license from TI under the patents or other intellectual property of TI.

Reproduction of TI information in TI data books or data sheets is permissible only if reproduction is without alteration and is accompanied by all associated warranties, conditions, limitations, and notices. Reproduction of this information with alteration is an unfair and deceptive business practice. TI is not responsible or liable for such altered documentation. Information of third parties may be subject to additional restrictions.

Resale of TI products or services with statements different from or beyond the parameters stated by TI for that product or service voids all express and any implied warranties for the associated TI product or service and is an unfair and deceptive business practice. TI is not responsible or liable for any such statements.

TI products are not authorized for use in safety-critical applications (such as life support) where a failure of the TI product would reasonably be expected to cause severe personal injury or death, unless officers of the parties have executed an agreement specifically governing such use. Buyers represent that they have all necessary expertise in the safety and regulatory ramifications of their applications, and acknowledge and agree that they are solely responsible for all legal, regulatory and safety-related requirements concerning their products and any use of TI products in such safety-critical applications, notwithstanding any applications-related information or support that may be provided by TI. Further, Buyers must fully indemnify TI and its representatives against any damages arising out of the use of TI products in such safety-critical applications.

TI products are neither designed nor intended for use in military/aerospace applications or environments unless the TI products are specifically designated by TI as military-grade or "enhanced plastic." Only products designated by TI as military-grade meet military specifications. Buyers acknowledge and agree that any such use of TI products which TI has not designated as military-grade is solely at the Buyer's risk, and that they are solely responsible for compliance with all legal and regulatory requirements in connection with such use.

TI products are neither designed nor intended for use in automotive applications or environments unless the specific TI products are designated by TI as compliant with ISO/TS 16949 requirements. Buyers acknowledge and agree that, if they use any non-designated products in automotive applications, TI will not be responsible for any failure to meet such requirements.

Following are URLs where you can obtain information on other Texas Instruments products and application solutions:

<b>Products</b>		<b>Applications</b>	
Amplifiers	<a href="http://amplifier.ti.com">amplifier.ti.com</a>	Audio	<a href="http://www.ti.com/audio">www.ti.com/audio</a>
Data Converters	<a href="http://dataconverter.ti.com">dataconverter.ti.com</a>	Automotive	<a href="http://www.ti.com/automotive">www.ti.com/automotive</a>
DSP	<a href="http://dsp.ti.com">dsp.ti.com</a>	Broadband	<a href="http://www.ti.com/broadband">www.ti.com/broadband</a>
Interface	<a href="http://interface.ti.com">interface.ti.com</a>	Digital Control	<a href="http://www.ti.com/digitalcontrol">www.ti.com/digitalcontrol</a>
Logic	<a href="http://logic.ti.com">logic.ti.com</a>	Military	<a href="http://www.ti.com/military">www.ti.com/military</a>
Power Mgmt	<a href="http://power.ti.com">power.ti.com</a>	Optical Networking	<a href="http://www.ti.com/opticalnetwork">www.ti.com/opticalnetwork</a>
Microcontrollers	<a href="http://microcontroller.ti.com">microcontroller.ti.com</a>	Security	<a href="http://www.ti.com/security">www.ti.com/security</a>
RFID	<a href="http://www.ti-rfid.com">www.ti-rfid.com</a>	Telephony	<a href="http://www.ti.com/telephony">www.ti.com/telephony</a>
Low Power Wireless	<a href="http://www.ti.com/lpw">www.ti.com/lpw</a>	Video & Imaging	<a href="http://www.ti.com/video">www.ti.com/video</a>
		Wireless	<a href="http://www.ti.com/wireless">www.ti.com/wireless</a>

Mailing Address: Texas Instruments, Post Office Box 655303, Dallas, Texas 75265  
Copyright © 2007, Texas Instruments Incorporated