

## LM3466 Smart Linear LED Driver for Multi-Channel LED Systems

Check for Samples: [LM3466](#)

### FEATURES

- Easy to design and use for lighting systems consisting of multiple LED strings (support modular design)
- Automatically equalizes the current of every active LED string, even the forward voltage of each string is different
- Easy to pre-set and fine-tune current ratio among LED strings (e.g. color temperature adjustment or CRI enhancement)
- $\pm 1\%$  current accuracy at room temperature and  $\pm 1.5\%$  over temperature
- Maintains constant output power if some strings open (inactive) by automatically equalizing the current of remaining active LED strings
- Works with a constant current power supply (ac/dc or dc/dc), and no communication to/from the constant current power supply is

required

- Operates with minimum voltage overhead to maximize power efficiency
- Wide input voltage range from 6V to 70V
- Fault status output
- Thermal shutdown
- Integrated 70V 1.5A MOSFET with 2.06A current limit
- Maximum 70V per LED string, 20 LEDs
- Linear circuitry does not deteriorate EMI
- PSOP-8 exposed DAP and TO220-7 packages

### APPLICATIONS

- Street lamps
- Solid state lighting systems

### DESCRIPTION

The LM3466 integrates a linear LED driver for lighting systems which consist of multiple LED strings powered by a constant current power supply. It equalizes the current provided by the supply in a pre-set ratio for each active LED string, where an active string is a fully turned on LED string, regardless of the number of strings connected to the supply or the forward voltage of each LED string. If any LED string opens during operation, the LM3466 automatically equalizes the supply current through all of the remaining active LED strings. As a result, the overall brightness of the lighting system is maintained even if some LED strings open during operation.

The LM3466 lighting system is simple to design owing to a proprietary control scheme. To minimize the component count, the LM3466 integrates a 70V, 1.5A N-channel power MOSFET with a current limit of 2.06A. To add one more LED string to the system, only a single resistor, a capacitor, and a LM3466 are required. Other supervisory features of the LM3466 include under-voltage lock-out, fault reporting, thermal latch off, and thermal shutdown protection.

The LM3466 consists of only linear circuitry so that the EMI of the application circuit is not deteriorated. The LM3466 lighting system is EMI friendly if the constant current power supply used is complied to EMI standards. The LM3466 is available in the PSOP-8 exposed DAP and TO220-7 packages.



Please be aware that an important notice concerning availability, standard warranty, and use in critical applications of Texas Instruments semiconductor products and disclaimers thereto appears at the end of this data sheet.

All trademarks are the property of their respective owners.

## Typical Application

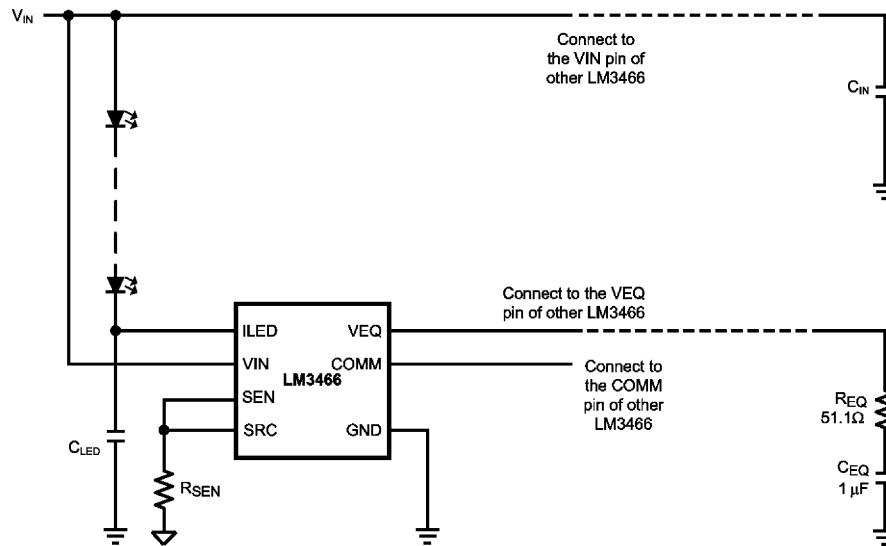

## Connection Diagram

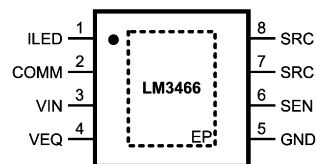

Figure 1. Top View  
ePSOP-8

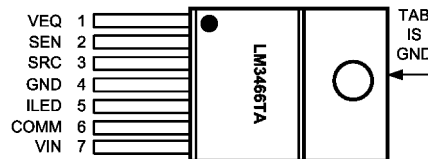

Figure 2. Top View  
TO220-7

## Pin Functions

### Pin Descriptions

Pin		Name	Description	Application Information
ePSOP-8	TO220-7			
1	5	ILED	Current Regulator Input	Connects to the drain of the integrated power MOSFET. Connects this pin to the cathode of an LED string. Connects a capacitor from this pin to ground to minimize noise if the connecting cable to the LED string is long.
2	6	COMM	Open-drain Status Output	Indicates the status of the LM3466 including startup, LED string active/inactive, TSD.
3	7	VIN	Input Voltage Supply	Connects to voltage supply from 6V to 70V. Connects a 10 nF capacitor from this pin to ground for decoupling.
4	1	VEQ	Control Voltage	Connects to the VEQ pin of other LM3466 with a 51Ω resistor in series with a 1 μF capacitor to ground.
5	4	GND	Ground	Connects to ground.

### Pin Descriptions (continued)

Pin		Name	Description	Application Information
ePSOP-8	TO220-7			
6	2	SEN	Current Sense Input	Senses the voltage of an external current sensing resistor.
7,8	3	SRC	Source of Power MOSFET	Connects to the source of the integrated power MOSFET. Connects this pin to an external current sensing resistor.
DAP		DAP	Exposed Pad	Thermal connection pad. Connects to a ground plane.



These devices have limited built-in ESD protection. The leads should be shorted together or the device placed in conductive foam during storage or handling to prevent electrostatic damage to the MOS gates.

### Absolute Maximum Ratings <sup>(1)</sup>

VIN, ILED to GND	-0.3V to 75V
COMM to GND	-0.3V to 7V
SEN, SRC, VEQ to GND	-0.3V to 5V
ESD Rating <sup>(2)</sup>	
Human Body Model	±2 kV
Storage Temperature Range	-65°C to + 150°C
Junction Temperature (T <sub>J</sub> )	+ 150°C

- (1) Absolute Maximum Ratings are limits beyond which damage to the device may occur. Operating Ratings are conditions under which operation of the device is intended to be functional. For guaranteed specifications and test conditions, see the Electrical Characteristics.
- (2) The human body model is a 100 pF capacitor discharged through a 1.5 kΩ resistor into each pin.

### Operating Ratings

Supply Voltage Range (VIN)	6V to 70V
Junction Temperature Range (T <sub>J</sub> )	-40°C to + 125°C
Thermal Resistance (θ <sub>JC</sub> )	
ePSOP-8 <sup>(1)</sup>	12.8 °C/W
TO220-7 <sup>(2)</sup>	2.5 °C/W

- (1) θ<sub>JC</sub> measurements are performed in general accordance with Mil-Std 883B, Method 1012.1 and utilize the copper heat sink technique. Copper Heat Sink @ 18°C with an ambient temperature @ 22°C.
- (2) θ<sub>JC</sub> measurements are performed in general accordance with Mil-Std 883B, Method 1012.1 and utilize the copper heat sink technique. Copper Heat Sink @ 60°C.

## Electrical Characteristics

Specification with standard type are for  $T_A = T_J = +25^\circ\text{C}$  only; limits in **boldface** type apply over the full Operating Junction Temperature ( $T_J$ ) range. Minimum and Maximum are guaranteed through test, design or statistical correlation. Typical values represent the most likely parametric norm at  $T_J = +25^\circ\text{C}$ , and are provided for reference purposes only. Unless otherwise stated, the following conditions apply:  $V_{IN} = 48\text{V}$ .

Symbol	Parameter	Conditions	Min	Typ	Max	Units
$V_{IN-UVLO-UPPER}$	VIN pin under-voltage lockout (UVLO) upper threshold	$V_{IN}$ increasing	<b>4.06</b>	4.78	<b>5.30</b>	V
$V_{IN-UVLO-HYS}$	VIN pin UVLO hysteresis	$V_{IN}$ decreasing		0.52		V
$I_{IN}$	Operating current to the VIN pin			550	<b>640</b>	$\mu\text{A}$
$V_{SEN}$	The SEN pin voltage regulation	$V_{EQ} = 200\text{ mV}$	197.1	200	201.0	mV
			<b>195.6</b>	200	<b>201.5</b>	mV
$I_{SEN}$	SEN pin bias current out (ePSOP-8)	$V_{SEN} = 0\text{V}$	<b>9.77</b>	10.5	<b>11.23</b>	$\mu\text{A}$
	SEN pin bias current out (TO220-7)	$V_{SEN} = 0\text{V}$	<b>9.35</b>	10.29	<b>11.23</b>	$\mu\text{A}$
$I_{LED-OFF}$	ILED pin off current	$V_{ILED} = 70\text{V}$		0.1	<b>0.6</b>	$\mu\text{A}$
$R_{DS(on)}$	Integrated power MOSFET on-resistance	$I_{ILED} = 300\text{ mA}$		0.5	<b>1.2</b>	$\Omega$
$V_{SRC-OPEN}$	SRC pin open circuit threshold	$V_{SEN} = V_{SRC}, V_{COMM} = 0\text{V}$	<b>25</b>	31	<b>37</b>	mV
$I_{LIMIT}$	Current Limit	$V_{SEN} = V_{SRC} = 0\text{V}, V_{ILED} = 3\text{V}$	1.75	2.06	2.35	A
$COMM_{ILOW}$	COMM pin pull-low current	$V_{COMM} = 5\text{V}$		34	<b>54</b>	$\mu\text{A}$
$COMM_{VHIGH}$	COMM pin pull-high voltage	COMM pin to ground through a 10 k $\Omega$		6.0		V
$T_{SD}$	Thermal Shutdown			150		$^\circ\text{C}$

### Typical Performance Characteristics

Unless otherwise specified the following conditions apply:  $T_J = 25^\circ\text{C}$ ,  $V_{IN} = 48\text{V}$  with configuration in the additional application circuit for  $I_{LED} = 0.35\text{A}$  shown in this datasheet.

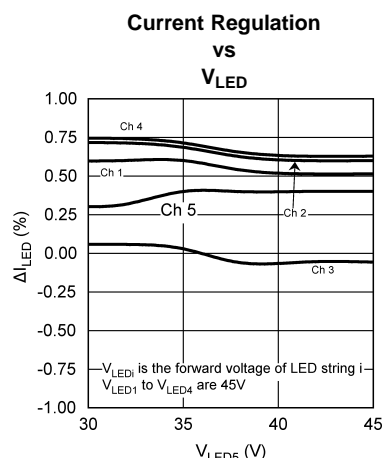
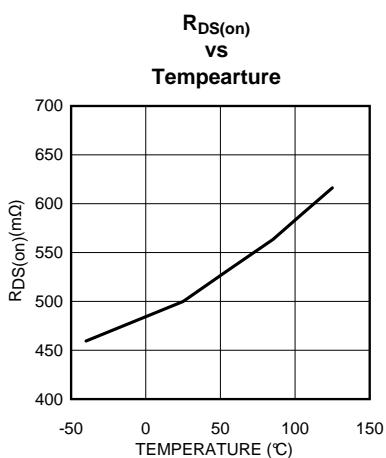
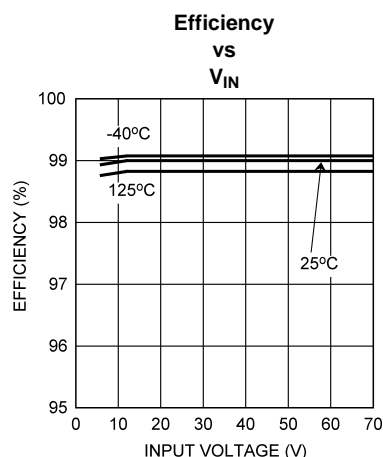
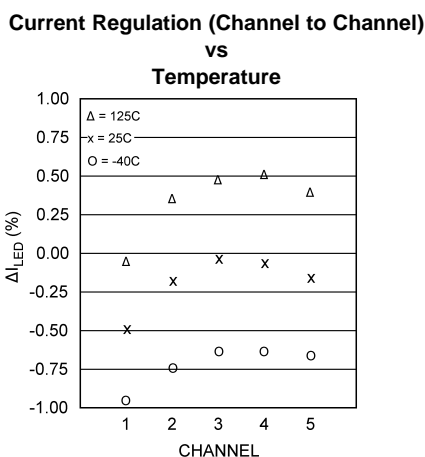
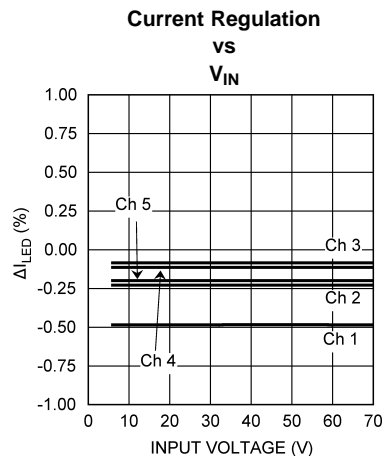
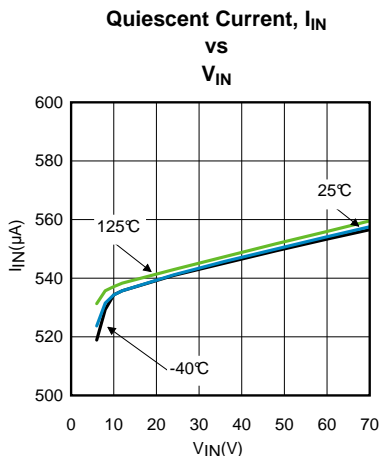

### Typical Performance Characteristics (continued)

Unless otherwise specified the following conditions apply:  $T_J = 25^\circ\text{C}$ ,  $V_{IN} = 48\text{V}$  with configuration in the additional application circuit for  $I_{LED} = 0.35\text{A}$  shown in this datasheet.

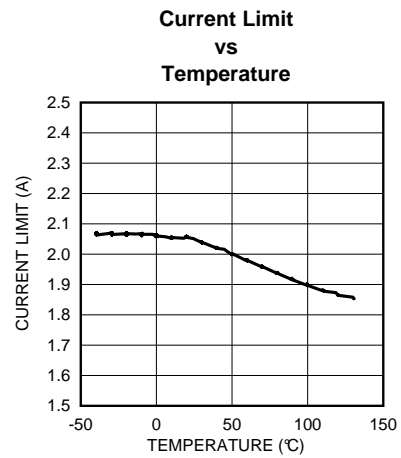
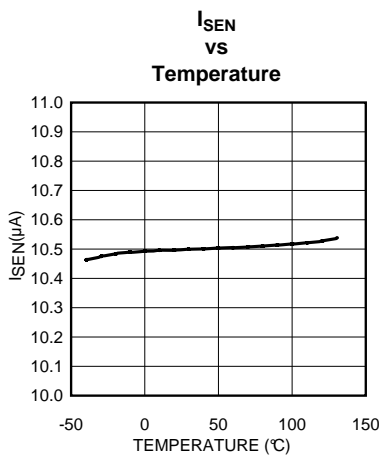
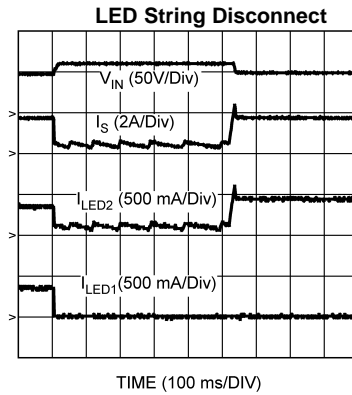
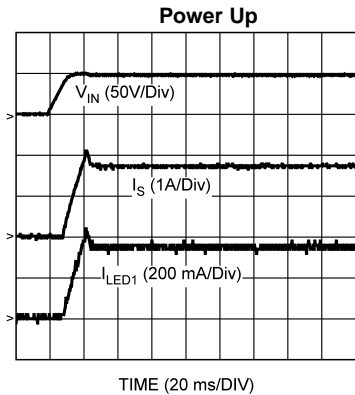

### Block Diagram

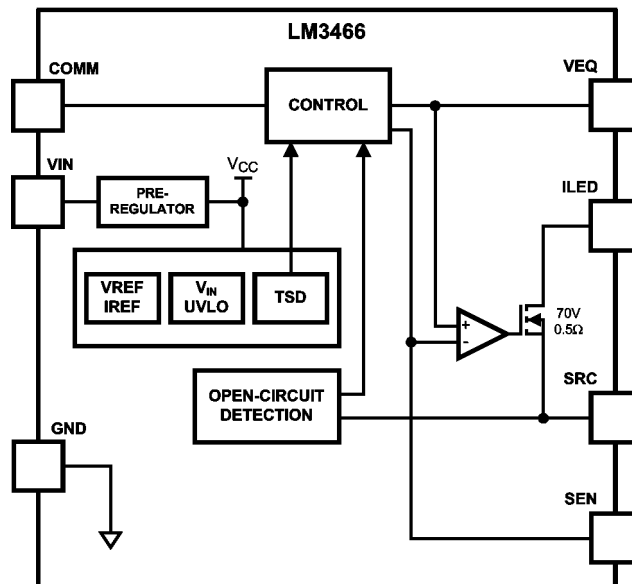

## Overview

The LM3466 integrates a linear LED driver for lighting systems which consist of multiple LED strings powered by a constant current power supply. An ideal constant current power supply delivers a constant current ( $I_S$ ) regardless of the output voltage of the connecting load. In the lighting system, each LM3466 regulates the current of an LED string. The current  $I_S$  provided by the supply is equalized (i.e. shared in a pre-set ratio determined by a single resistor) through each active LED string automatically, regardless of the number of strings connected to the supply or the forward voltage of each string. Here, an active LED string refers to a fully turned on LED string. If any LED string opens during operation, the LED current of all remaining active LED strings will increase to equalize the current provided by the supply automatically. As a result, the total output power remains nearly the same in case of the decrease of active LED strings. This gives an advantage that the overall brightness of the lighting system is maintained even if some LED strings open during operation.

A LM3466 lighting system is simple to design owing to a proprietary control scheme. To minimize the component count, the LM3466 integrates a 70V, 1.5A N-channel MOSFET with a current limit of 2.06A. To add one more LED string to the system, only a single resistor, a capacitor, and an LM3466 are required. Other supervisory features of the LM3466 include under-voltage lock-out, fault reporting, thermal latchoff, and thermal shutdown protection.

The LM3466 consists of only linear circuitry so that the EMI of the application circuit is not deteriorated. The LM3466 lighting system is EMI friendly if the constant current power supply used is complied to EMI standards. The LM3466 is available in a PSOP-8 exposed DAP and TO220-7 packages.

## Current Regulator

The LM3466 integrates a current regulator to control the current of a connected LED string. The current is delivered from the supply through the LED string, the ILED pin, the integrated power MOSFET, the SRC pin, and the sensing resistor  $R_{SEN}$  connecting from the SRC pin to ground (Figure 1). The voltage of the sensing resistor is fed back to the LM3466 through the SEN pin, either by direct connection or through an extra resistor  $R_{SL}$ . The LM3466 regulates the voltage of the SEN pin ( $V_{SEN}$ ) to a voltage set by its control block. If the sensing resistor of each LM3466 ( $R_{SEN,k}$ ,  $k = 1, 2, \dots, n$ ) is the same, the LED current of each active LED string is the same. If  $R_{SEN,k}$  of any LM3466 is different from others, the corresponding LED current ( $I_{LED,k}$ ) is different, while  $V_{SEN}$  of each LM3466 is still the same as others. The LED current of string  $k$  is

$$I_{LED,k} = \frac{I_S R_{TOTAL}}{R_{SEN,k}} \quad (1)$$

where  $I_S$  is the current of the supply, and

$$\frac{1}{R_{TOTAL}} = \sum_{i=1}^n \frac{1}{R_{SEN,i}} \quad (2)$$

In addition to determining the LED current by means of  $R_{SEN,k}$ , an external resistor  $R_{SL,k}$  connecting between the SEN pin and  $R_{SEN,k}$  can be used to fine tune the LED current for the purpose of color temperature adjustment or CRI enhancement. The SEN pin sources a constant bias current of 10.29  $\mu$ A such that a constant voltage drop on  $R_{SL,k}$  reduces the LED current. Using an external resistor  $R_{SL,k}$  affects the current of other LED strings. If  $R_{SL,k}$  is added in the  $k$ -th LM3466, the corresponding LED current is

$$I_{LED,k} = \frac{I_S R_{TOTAL} - 10.29 \mu A R_{SL,k} R_{TOTAL}}{R_{SEN,k}} \left( \frac{1}{R_{TOTAL}} - \frac{1}{R_{SEN,k}} \right) \quad (3)$$

and the LED current of other strings is

$$I_{LED,i} = \frac{I_S R_{TOTAL} - 10.29 \mu A \frac{R_{SL,k} R_{TOTAL}}{R_{SEN,k}}}{R_{SEN,i}}$$

(4)

where  $i = 1, 2, \dots, n$  except  $k$ . The LED current of LED string  $k$  is reduced, while the LED current of other channels increases. Figure 2 shows a typical example that the variation of LED current on varying  $R_{SL,k}$ .

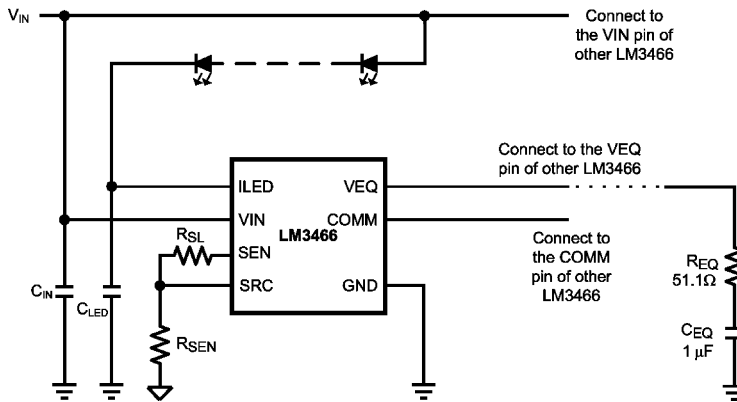

Figure 3. A Single LM3466 within a Lighting System

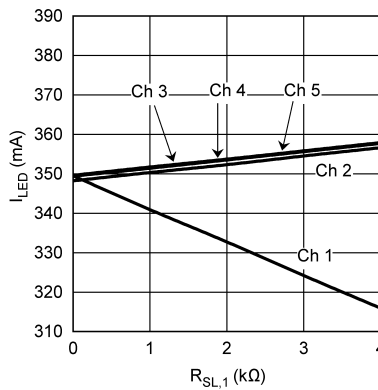

Figure 4. Variation of  $I_{LED}$  vs  $R_{SL,k}$

### LED String Disconnect and Reconnect

One major advantage of the LM3466 lighting system is that the overall brightness can be maintained even if some LED strings open during operation. If an active LED string is suddenly disconnected, the LM3466 will automatically equalize the current delivered by the supply  $I_S$  (i.e. each string increases its LED current in this case) so as to keep  $I_S$  constant. However, the equalization takes place only after the LED string is confirmed inactive. Once the string is disconnected,  $V_{EQ}$  will go to a cycle (goes up and down). If the string is still disconnected for a period of 253 consecutive cycles, the string is confirmed inactive. Consequently, the current of other LED strings increases to equalize  $I_S$ . The output power and the overall brightness of the lighting system can be maintained.



If a new LED string connects to the system, such as if the disconnected LED string is reconnected again, a power reset is recommended to ensure proper operation. The forward voltage of the new LED string may be higher than the instantaneous  $V_{IN}$ , which corresponds to the forward voltage of the highest active LED string. A power reset ensures that  $V_{IN}$  goes to the peak voltage (a default characteristic of a constant current power supply) in order to start up the LED string with the highest forward voltage.

### Communication Pin

The COMM pin serves as a communication link among all LM3466 in the lighting system. It also indicates the status of the device. The COMM pin is pulled low at startup. After startup, the COMM pin is high/low to indicate that the corresponding LED string is active/inactive.

For proper operation of a LM3466 system, the COMM pin of all LM3466 should be either shorted together or connected through a diode in parallel with a resistor. Figure 3 shows an optional circuit for the COMM pin to indicate whether each LED string is active by means of small signal LEDs. The COMM pin of each LM3466 is connected to an external test point COMM\_ALL through the optional circuit.

The COMM pin is low if the LM3466 is under thermal protection.

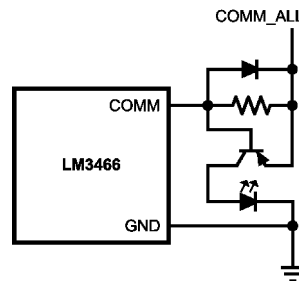

Figure 5. Optional Circuit for the COMM Pin

### High Voltage Application

For any application with the forward voltage of an LED string higher than 70V, which is the maximum operating voltage of the LM3466, an external MOSFET circuit as shown in Figure 4 is recommended for each channel in order to protect the ILED pin from damaging by a high voltage owing to shorting LEDs (or even the whole LED string). To avoid the ILED pin damage from a high voltage generated by the leakage current, a resistor  $R_{LED}$  (1 M $\Omega$  is suggested) is placed between the ILED pin and ground. In addition, since  $V_{LED}$  is higher than 70V in this case, the VIN pin cannot be directly connected to  $V_{LED}$ . External power supplies for  $V_{IN}$  and  $V_G$  (to drive the external MOSFET) are required. Alternatively, Figure 5 shows a circuit for supplying  $V_{IN}$  and  $V_G$  (for all channels in the system).



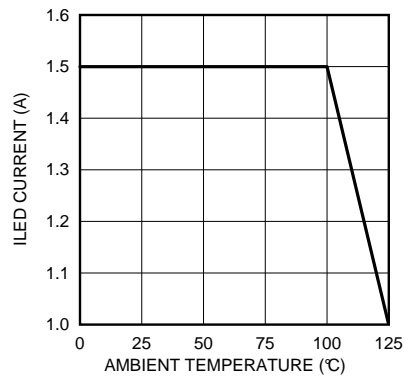

Figure 8. Thermal Derating Curve for the ePSOP-8 Package

### Application Information

Consider a LM3466 lighting system which is powered by a 1.75A constant current power supply and consists of 5 LED strings with 14 LEDs per string. It is designed that the LED current of every LED string is 0.35A.

### EXTERNAL COMPONENTS

**R<sub>SEN</sub>:** To set the LED current of all 5 LED strings equal, the sensing resistors corresponding to all 5 LM3466 are equal. It is recommended that the nominal voltage of the SEN pin  $V_{SEN}$  should be around 0.3V. Therefore,  $R_{SEN}$  is selected to be 1 $\Omega$ . As a result,  $V_{SEN}$  should be 0.35V if the LED current is 0.35A.

**C<sub>LED</sub>:** If the cable connecting the LED string is long, the parasitic inductance of the cable may generate noise. If this happens, a high quality ceramic capacitor should be connected between the ILED pin and ground. In this example, a 100V, 1  $\mu$ F ceramic capacitor is used.

**C<sub>IN</sub>:** A high quality ceramic capacitor for decoupling should be connected from the VIN pin to ground. In this example, a 100V, 0.01  $\mu$ F ceramic capacitor is used.

**R<sub>EQ</sub> and C<sub>EQ</sub>:** The VEQ pins of all LM3466 are shorted together and then connected to ground through  $R_{EQ}$  and  $C_{EQ}$ . Only one  $R_{EQ}$  and one  $C_{EQ}$  are required for each LM3466 lighting system. It is recommended that  $R_{EQ}$  be 51.1 $\Omega$  and  $C_{EQ}$  be 1  $\mu$ F.

### PC BOARD LAYOUT

To minimize the effect of noise, the ground connections of the LM3466 and the sense resistor  $R_{SEN,k}$  should be closed. Good heat dissipation helps optimize the performance of the LM3466. The ground plane should be used to connect the exposed pad of the LM3466, which is internally connected to the LM3466 die substrate. The area of the ground plane should be extended as much as possible on the same copper layer above and below the LM3466. Using numerous vias beneath the exposed pad to dissipate heat of the LM3466 to another copper layer is also a good practice.

Additional Application Circuit

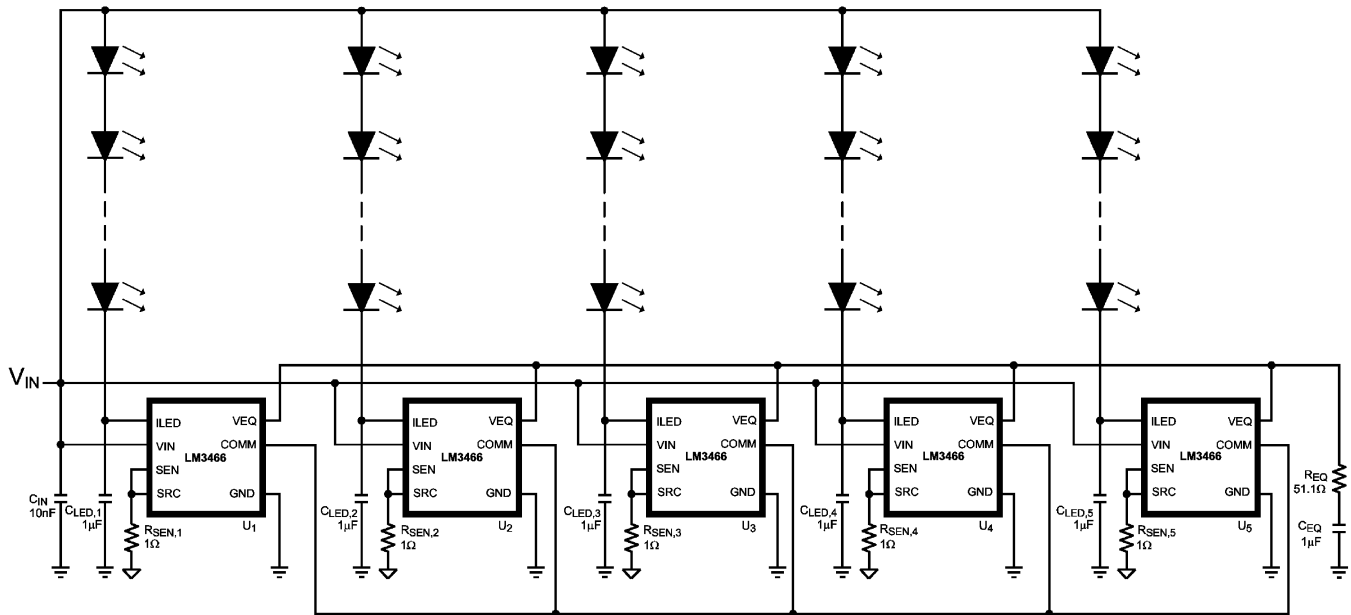

Figure 9. Application Circuit of a LM3466 Lighting System

## PACKAGING INFORMATION

Orderable Device	Status (1)	Package Type	Package Drawing	Pins	Package Qty	Eco Plan (2)	Lead/Ball Finish	MSL Peak Temp (3)	Op Temp (°C)	Top-Side Markings (4)	Samples
LM3466MR/NOPB	ACTIVE	SO PowerPAD	DDA	8	95	Green (RoHS & no Sb/Br)	CU SN	Level-3-260C-168 HR	-40 to 125	L3466	<a href="#">Samples</a>
LM3466MRX/NOPB	ACTIVE	SO PowerPAD	DDA	8	2500	Green (RoHS & no Sb/Br)	CU SN	Level-3-260C-168 HR	-40 to 125	L3466	<a href="#">Samples</a>

(1) The marketing status values are defined as follows:

**ACTIVE:** Product device recommended for new designs.

**LIFEBUY:** TI has announced that the device will be discontinued, and a lifetime-buy period is in effect.

**NRND:** Not recommended for new designs. Device is in production to support existing customers, but TI does not recommend using this part in a new design.

**PREVIEW:** Device has been announced but is not in production. Samples may or may not be available.

**OBSOLETE:** TI has discontinued the production of the device.

(2) Eco Plan - The planned eco-friendly classification: Pb-Free (RoHS), Pb-Free (RoHS Exempt), or Green (RoHS & no Sb/Br) - please check <http://www.ti.com/productcontent> for the latest availability information and additional product content details.

**TBD:** The Pb-Free/Green conversion plan has not been defined.

**Pb-Free (RoHS):** TI's terms "Lead-Free" or "Pb-Free" mean semiconductor products that are compatible with the current RoHS requirements for all 6 substances, including the requirement that lead not exceed 0.1% by weight in homogeneous materials. Where designed to be soldered at high temperatures, TI Pb-Free products are suitable for use in specified lead-free processes.

**Pb-Free (RoHS Exempt):** This component has a RoHS exemption for either 1) lead-based flip-chip solder bumps used between the die and package, or 2) lead-based die adhesive used between the die and leadframe. The component is otherwise considered Pb-Free (RoHS compatible) as defined above.

**Green (RoHS & no Sb/Br):** TI defines "Green" to mean Pb-Free (RoHS compatible), and free of Bromine (Br) and Antimony (Sb) based flame retardants (Br or Sb do not exceed 0.1% by weight in homogeneous material)

(3) MSL, Peak Temp. -- The Moisture Sensitivity Level rating according to the JEDEC industry standard classifications, and peak solder temperature.

(4) Only one of markings shown within the brackets will appear on the physical device.

**Important Information and Disclaimer:** The information provided on this page represents TI's knowledge and belief as of the date that it is provided. TI bases its knowledge and belief on information provided by third parties, and makes no representation or warranty as to the accuracy of such information. Efforts are underway to better integrate information from third parties. TI has taken and continues to take reasonable steps to provide representative and accurate information but may not have conducted destructive testing or chemical analysis on incoming materials and chemicals. TI and TI suppliers consider certain information to be proprietary, and thus CAS numbers and other limited information may not be available for release.

In no event shall TI's liability arising out of such information exceed the total purchase price of the TI part(s) at issue in this document sold by TI to Customer on an annual basis.

**TAPE AND REEL INFORMATION**

**QUADRANT ASSIGNMENTS FOR PIN 1 ORIENTATION IN TAPE**

\*All dimensions are nominal

Device	Package Type	Package Drawing	Pins	SPQ	Reel Diameter (mm)	Reel Width W1 (mm)	A0 (mm)	B0 (mm)	K0 (mm)	P1 (mm)	W (mm)	Pin1 Quadrant
LM3466MRX/NOPB	SO Power PAD	DDA	8	2500	330.0	12.4	6.5	5.4	2.0	8.0	12.0	Q1

**TAPE AND REEL BOX DIMENSIONS**

\*All dimensions are nominal

Device	Package Type	Package Drawing	Pins	SPQ	Length (mm)	Width (mm)	Height (mm)
LM3466MRX/NOPB	SO PowerPAD	DDA	8	2500	358.0	343.0	63.0

DDA0008A

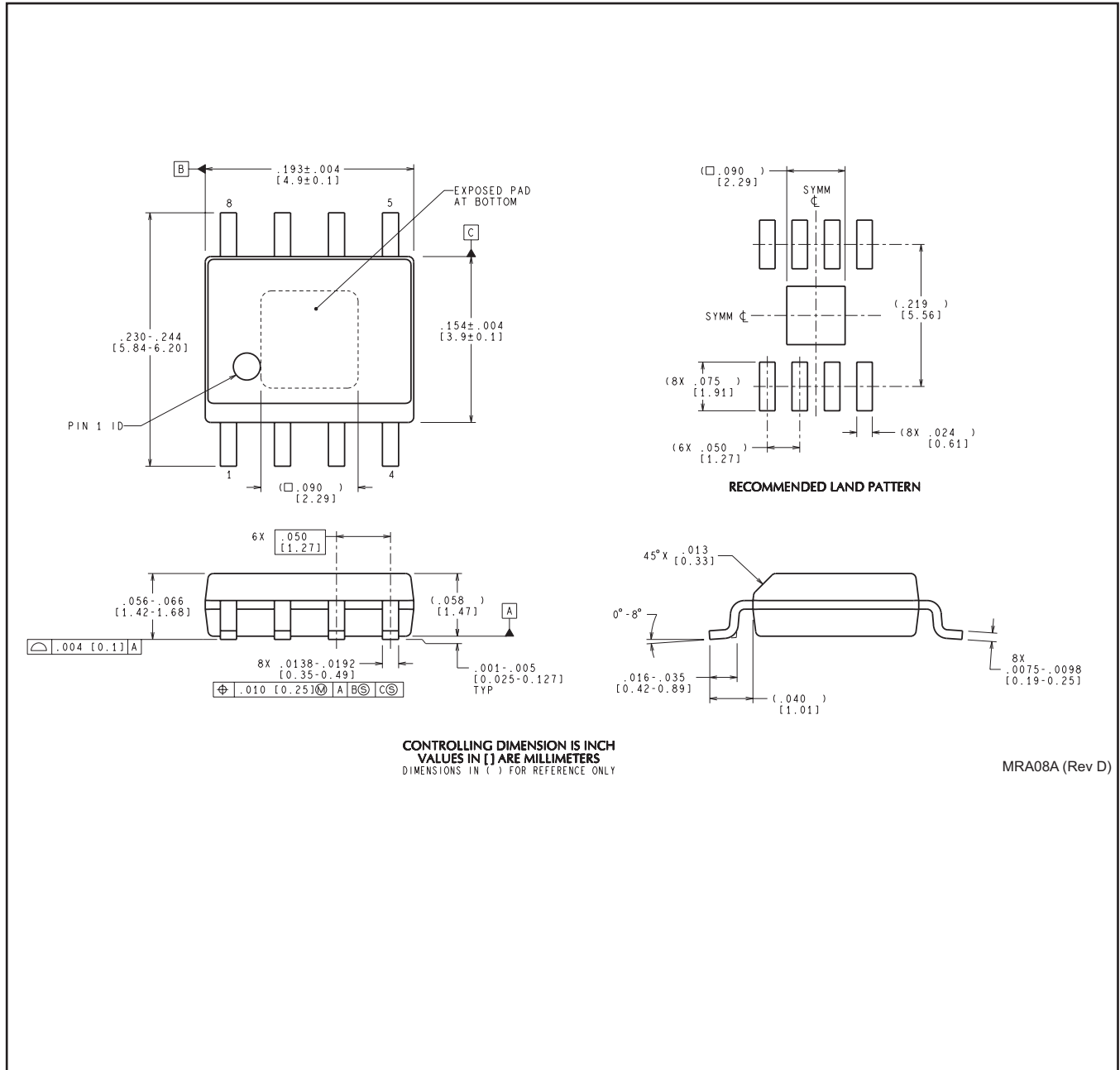

MRA08A (Rev D)



## IMPORTANT NOTICE

Texas Instruments Incorporated and its subsidiaries (TI) reserve the right to make corrections, enhancements, improvements and other changes to its semiconductor products and services per JESD46, latest issue, and to discontinue any product or service per JESD48, latest issue. Buyers should obtain the latest relevant information before placing orders and should verify that such information is current and complete. All semiconductor products (also referred to herein as "components") are sold subject to TI's terms and conditions of sale supplied at the time of order acknowledgment.

TI warrants performance of its components to the specifications applicable at the time of sale, in accordance with the warranty in TI's terms and conditions of sale of semiconductor products. Testing and other quality control techniques are used to the extent TI deems necessary to support this warranty. Except where mandated by applicable law, testing of all parameters of each component is not necessarily performed.

TI assumes no liability for applications assistance or the design of Buyers' products. Buyers are responsible for their products and applications using TI components. To minimize the risks associated with Buyers' products and applications, Buyers should provide adequate design and operating safeguards.

TI does not warrant or represent that any license, either express or implied, is granted under any patent right, copyright, mask work right, or other intellectual property right relating to any combination, machine, or process in which TI components or services are used. Information published by TI regarding third-party products or services does not constitute a license to use such products or services or a warranty or endorsement thereof. Use of such information may require a license from a third party under the patents or other intellectual property of the third party, or a license from TI under the patents or other intellectual property of TI.

Reproduction of significant portions of TI information in TI data books or data sheets is permissible only if reproduction is without alteration and is accompanied by all associated warranties, conditions, limitations, and notices. TI is not responsible or liable for such altered documentation. Information of third parties may be subject to additional restrictions.

Resale of TI components or services with statements different from or beyond the parameters stated by TI for that component or service voids all express and any implied warranties for the associated TI component or service and is an unfair and deceptive business practice. TI is not responsible or liable for any such statements.

Buyer acknowledges and agrees that it is solely responsible for compliance with all legal, regulatory and safety-related requirements concerning its products, and any use of TI components in its applications, notwithstanding any applications-related information or support that may be provided by TI. Buyer represents and agrees that it has all the necessary expertise to create and implement safeguards which anticipate dangerous consequences of failures, monitor failures and their consequences, lessen the likelihood of failures that might cause harm and take appropriate remedial actions. Buyer will fully indemnify TI and its representatives against any damages arising out of the use of any TI components in safety-critical applications.

In some cases, TI components may be promoted specifically to facilitate safety-related applications. With such components, TI's goal is to help enable customers to design and create their own end-product solutions that meet applicable functional safety standards and requirements. Nonetheless, such components are subject to these terms.

No TI components are authorized for use in FDA Class III (or similar life-critical medical equipment) unless authorized officers of the parties have executed a special agreement specifically governing such use.

Only those TI components which TI has specifically designated as military grade or "enhanced plastic" are designed and intended for use in military/aerospace applications or environments. Buyer acknowledges and agrees that any military or aerospace use of TI components which have **not** been so designated is solely at the Buyer's risk, and that Buyer is solely responsible for compliance with all legal and regulatory requirements in connection with such use.

TI has specifically designated certain components as meeting ISO/TS16949 requirements, mainly for automotive use. In any case of use of non-designated products, TI will not be responsible for any failure to meet ISO/TS16949.

### Products

Audio	<a href="http://www.ti.com/audio">www.ti.com/audio</a>
Amplifiers	<a href="http://amplifier.ti.com">amplifier.ti.com</a>
Data Converters	<a href="http://dataconverter.ti.com">dataconverter.ti.com</a>
DLP® Products	<a href="http://www.dlp.com">www.dlp.com</a>
DSP	<a href="http://dsp.ti.com">dsp.ti.com</a>
Clocks and Timers	<a href="http://www.ti.com/clocks">www.ti.com/clocks</a>
Interface	<a href="http://interface.ti.com">interface.ti.com</a>
Logic	<a href="http://logic.ti.com">logic.ti.com</a>
Power Mgmt	<a href="http://power.ti.com">power.ti.com</a>
Microcontrollers	<a href="http://microcontroller.ti.com">microcontroller.ti.com</a>
RFID	<a href="http://www.ti-rfid.com">www.ti-rfid.com</a>
OMAP Applications Processors	<a href="http://www.ti.com/omap">www.ti.com/omap</a>
Wireless Connectivity	<a href="http://www.ti.com/wirelessconnectivity">www.ti.com/wirelessconnectivity</a>

### Applications

Automotive and Transportation	<a href="http://www.ti.com/automotive">www.ti.com/automotive</a>
Communications and Telecom	<a href="http://www.ti.com/communications">www.ti.com/communications</a>
Computers and Peripherals	<a href="http://www.ti.com/computers">www.ti.com/computers</a>
Consumer Electronics	<a href="http://www.ti.com/consumer-apps">www.ti.com/consumer-apps</a>
Energy and Lighting	<a href="http://www.ti.com/energy">www.ti.com/energy</a>
Industrial	<a href="http://www.ti.com/industrial">www.ti.com/industrial</a>
Medical	<a href="http://www.ti.com/medical">www.ti.com/medical</a>
Security	<a href="http://www.ti.com/security">www.ti.com/security</a>
Space, Avionics and Defense	<a href="http://www.ti.com/space-avionics-defense">www.ti.com/space-avionics-defense</a>
Video and Imaging	<a href="http://www.ti.com/video">www.ti.com/video</a>

### TI E2E Community

[e2e.ti.com](http://e2e.ti.com)