

The EQ-board is connected with 3 wires (white, red and black) to points a and b on the main PCB.

This is a standard Marshall tone stack, where the treble and mids pot are replaced by fix resistors. If you use a 220k pot for R16/17 and a 25k pot for R18, you will have a standard TMB stack. The Valve Jr. has R15 (1,5k) between a and b.

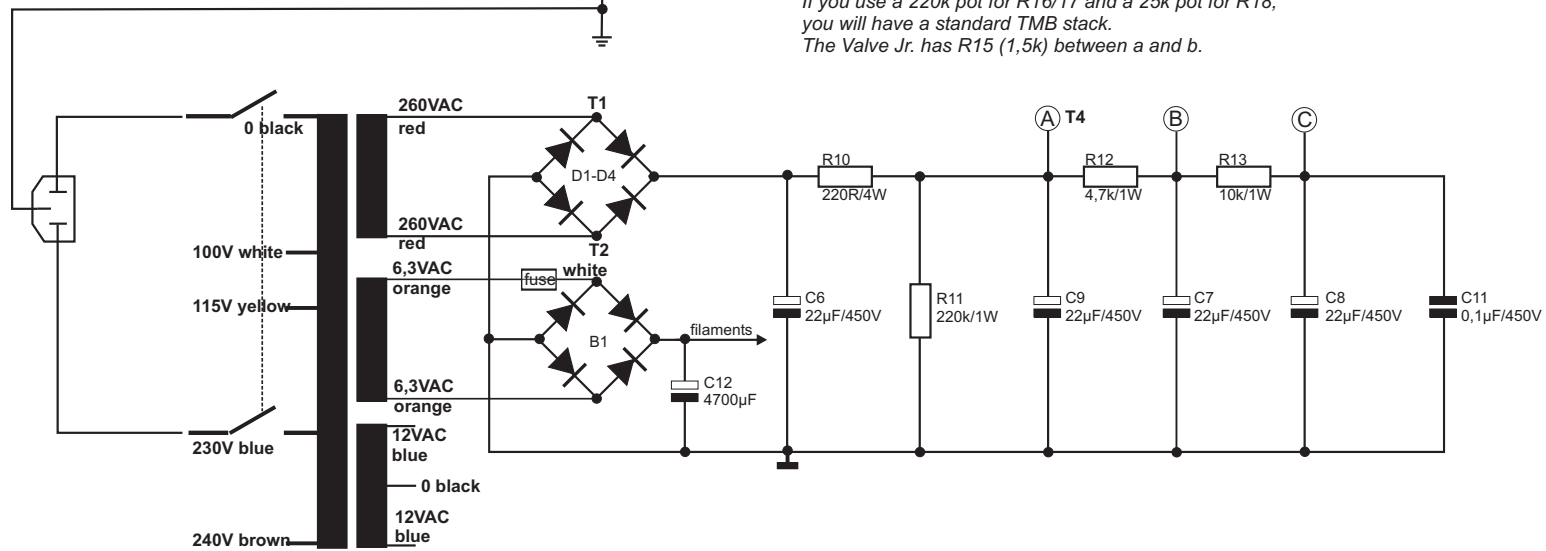

V1: ECC83
V2: EL84
D1-D4: 1N4007

Edition	Datum	Name	Harley Benton GA5	Blatt
1	Mar-04-2008	Striker52		1
			Stock schematics	Filename
				HB-GA5-Stock.cdr