

COLOR TELEVISION

SERVICE MANUAL

CHASSIS NO. ETE-3

Please read this manual carefully before service.

1. SAFETY INSTRUCTIONS AND MAINTENANCE

WARNING: BEFORE SERVICING THIS CHASSIS, READ THE “X-RAY RADIATION PRECAUTION”, “SAFETY PRECAUTION” AND “PRODUCT SAFETY NOTICE” INSTRUCTION BELOW.

1.1 X-RAY RADIATION PRECAUTION

1.1.1 The EHT must be checked every time the TV is serviced to ensure that the CRT does not emit X-ray radiation as result of excessive EHT voltage. The maximum EHT voltage permissible in any operating circumstances must not exceed the rated value. When checking the EHT, use the High Voltage Check procedure in this manual using an accurate EHT voltmeter.

1.1.2 The only source of X-RAY radiation in this TV is the CRT. The TV minimizes X-RAY radiation, which ensures safety during normal operation. To prevent X-ray radiation, the replacement CRT must be identical to the original fitted as specified in the parts list.

1.1.3 Some components used in this TV have safety related characteristics preventing the CRT from emitting X-ray radiation. For continued safety, replacement component should be made after referring the PRODUCT SAFETY NOTICE below.

1.1.4 Service and adjustment of the TV may result in changes in the nominal EHT voltage of the CRT anode. So ensure that the maximum EHT voltage does not exceed the rated value after service and adjustment.

1.2 SAFETY PRECAUTION

WARNING: REFER SERVICING TO QUALIFIED SERVICE PERSONNEL ONLY.

1.2.1 The TV has a nominal working EHT voltage. Extreme caution should be exercised when working on the TV with the back removed.

Do not attempt to service this TV if you are not conversant with the precautions and procedures for working on high voltage equipment.

When handling or working on the CRT, always discharge the anode to the TV chassis before removing the anode cap in case of electric shock.

The CRT, if broken, will violently expel glass fragments. Use shatterproof goggles and take extreme care while handling.

Do not hold the CRT by the neck as this is a very dangerous practice..

1.2.2 It is essential that to maintain the safety of the customer all power cord forms be replaced exactly as supplied from factory.

1.2.3 Voltage exists between the hot and cold ground when the TV is in operation. Install a suitable isolating transformer of beyond rated overall power when servicing or connecting any test equipment for the sake of safety.

1.2.4 When replacing ICs, use specific tools or a static-proof electric iron with small power (below 3 5W).

1.2.5 Do not use a magnetized screwdriver when tightening or loosening the deflection yoke assembly to avoid electronic gun magnetized and decrement in convergence of the CRT.

1.2.6 When remounting the TV chassis, ensure that all guard devices, such as nonmetal control buttons, switch, insulating sleeve, shielding cover, isolating resistors and capacitors, are installed on the original place.

1.2.7 Replace blown fuses within the TV with the fuse specified in the parts list.

1.2.8 When replacing wires or components to terminals or tags, wind the leads around the terminal before soldering. When replacing safety components identified by the international

hazard symbols on the circuit diagram and parts list, it must be the company-approved type and must be mounted as the original.

1.2.9 Keep wires away from high temperature components.

1.3 PRODUCT SAFETY NOTICE

CAUTION: FOR YOUR PROTECTION, THE FOLLOWING PRODUCT SAFETY NOTICE SHOULD BE READ CAREFULLY BEFORE OPERATING AND SERVICING THIS TV SET.

1.3.1 Many electrical and mechanical components in this chassis have special safety-related characteristics. These characteristics are often passed unnoticed by a visual inspection and the X-ray radiation protection afforded by them cannot necessarily be obtained by using replacements rated at higher voltages or wattage, etc. Components which have these special safety characteristics in this manual and its supplements are identified by the international hazard symbols on the circuit diagram and parts list. Before replacing any of these components read the parts list in this manual carefully. Substitute replacement components which do not have the same safety characteristics as specified in the parts list may create X-ray radiation.

1.3.2 Do not slap or beat the cabinet or CRT, since this may result in fire or explosion.

1.3.3 Never allow the TV sharing a plug or socket with other large-power equipment. Doing so may result in too large load, causing fire.

1.3.4 Do not allow anything to rest on or roll over the power cord. Protect the power cord from being walked on, modified, cut or pinched, particularly at plugs.

1.3.5 Do not place any objects, especially heavy objects and lightings, on top of the TV set. Do not install the TV near any heat sources such as radiators, heat registers, stove, or other apparatus that produce heat.

1.3.6 Service personnel should observe the SAFETY INSTRUCTIONS in this manual during use and servicing of this TV set. Otherwise, the resulted damage is not protected by the manufacturer.

1.4 SAFETY SYMBOL DESCRIPTION



The lightning symbol in the triangle tells you that the voltage inside this product may be strong enough to cause an electric shock. Extreme caution should be exercised when working on the TV with the back removed.



This is an international hazard symbol, telling you that the components identified by the symbol have special safety-related characteristics.

UL This symbol tells you that the critical components identified by the UL marking have special safety-related characteristics.

VDE or TUV This symbol tells you that the critical components identified by the VDE/TUV marking have special safety-related characteristics.

1.5 MAINTENANCE

1.5.1 Place the TV set on a stable stand or base that is of adequate size and strength to prevent it from being accidentally tipped over, pushed off, or pulled off. Do not place the set near or over a radiator or heat register, or where it is exposed to direct sunlight.

1.5.2 Do not install the TV set in a place exposed to rain, water, excessive dust, mechanical vibrations or impacts.

1.5.3 Allow enough space (at least 10cm) between the TV and wall or enclosures for proper ventilation.

1.5.4 Slots and openings in the cabinet should never be blocked by clothes or other objects.

1.5.5 Please power off the TV set and disconnect it from the wall immediately if any abnormal condition are met, such as bad smell, belching smoke, sparking, abnormal sound, no picture/sound/raster. Hold the plug firmly when disconnecting the power cord.

1.5.6 Unplug the TV set from the wall outlet before cleaning or polishing it. Use a dry soft cloth for cleaning the exterior of the TV set or CRT screen. Do not use liquid cleaners or aerosol cleaners.

2. ADJUSTMENTS

2.1 SET-UP ADJUSTMENTS

The following adjustments should be made when a complete realignment is required or a new picture tube is installed.

Perform the adjustments in the following order:

Color purity

Convergence

White balance

Notes:

The purity/convergence magnet assembly and rubber wedges need mechanical positioning.

For some picture tubes, purity/ convergence adjustments are not required.

2.1.1 Color Purity Adjustment

Preparation:

Before starting this adjustment, adjust the vertical sync, horizontal sync, vertical amplitude and focus.

•Face the TV set north or south.

- Connect the power plug into the wall outlet and turn on the main power switch of the TV set.
- Operate the TV for at least 15 minutes.
- Degauss the TV set using a specific degaussing coil.
- Set the brightness and contrast to maximum.
- Counter clockwise rotate the R /B low brightness potentiometers to the end and rotate the green low brightness potentiometer to center.
- Receive green raster pattern signals.
- Loosen the clamp screw holding the deflection yoke assembly and slide it forward or backward to display a vertical green zone on the screen. Rotate and spread the tabs of the purity magnet around the neck of the CRT until the green zone is located vertically at the center of the screen. •Slowly move the deflection yoke assembly forward or backward until a uniform green screen is obtained.
- Tighten the clamp screw of the assembly temporarily. Check purity of the red raster and blue raster until purities of the three rasters meet the requirement.

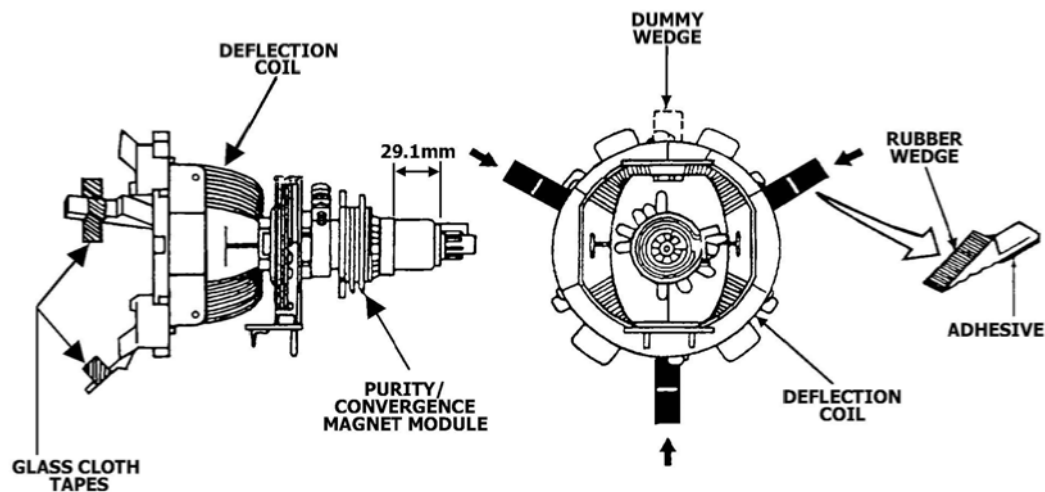

2.1.2 Convergence Adjustment

Preparation: Before attempting any convergence adjustment, the TV should be operated for at least 15 minutes.

- Center convergence adjustment.
- Receive dot pattern.
- Adjust the brightness/contrast controls to obtain a sharp picture.
- Adjust two tabs of the 4-pole magnet to change the angle between them and red and blue vertical lines are superimposed each other on the center of the screen.
- Turn both tabs at the same time keeping the angle constant to superimpose red and blue horizontal on the center of the screen.
- Adjust two tabs of the 6-pole magnet to superimpose red/blue line and green line.

- Remember red and blue movement. Repeat steps 2.1.3 2. 1.5 until optimal convergence is obtained.
- Circumference convergence adjustment.
- Loosen the clamp screw holding the deflection yoke assembly and allow it tilting.
- Temporarily put the first wedge between the picture tube and deflection yoke assembly. Move front of the deflection yoke up or down to obtain better convergence in circumference. Push the mounted wedge in to fix the yoke temporarily.
- Put the second wedge into bottom.
- Move front of the deflection yoke to the left or right to obtain better convergence in circumference.
- Fix the deflection yoke position and put the third wedge in either upper space. Fasten the deflection yoke assembly on the picture tube.
- Detach the temporarily mounted wedge and put it in either upper space. Fasten the deflection yoke assembly on the picture tube.
- After fastening the three wedges, recheck overall convergence and ensure to get optimal convergence. Tighten the lamp screw holding the deflection yoke assembly.

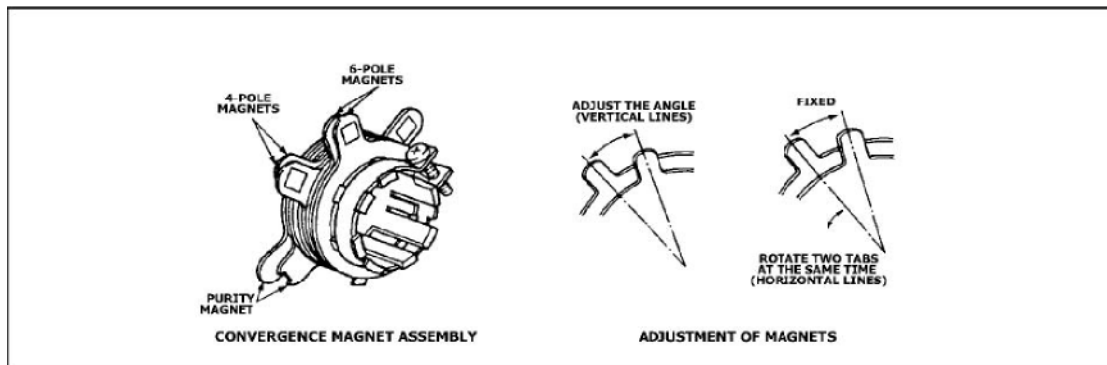

Fig. 2

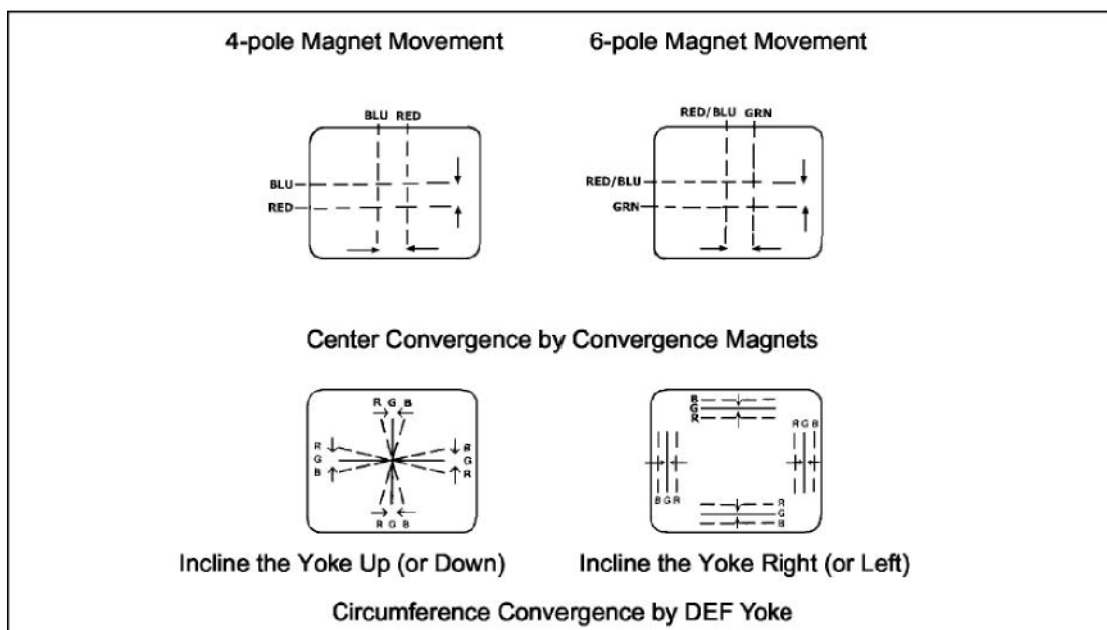

Fig.3

2.1.3 White Balance Adjustment

Generally, white balance adjustment is made with professional equipment. It's not practical to get good white balance only through manual adjustment. For TVs with I2C bus control, change the bus data to adjust white balance.

2.2 CIRCUIT ADJUSTMENTS

Preparation:

Circuit adjustments should be made only after completion of set-up adjustments.

Circuit adjustments can be performed using the adjustable components inside the TV set. For TVs with I2C bus control, first change the bus data.

2.2.1 Degaussing

A degaussing coil is built inside the TV set. Each time the TV is powered on, the degaussing coil will automatically degauss the TV. If the TV is magnetized by external strong magnetic field, causing color spot on the screen, use a specific degausser to demagnetize the TV in the following ways. Otherwise, color distortion will be shown on the screen.

- Power on the TV set and operate it for at least 15 minutes.
- Receive red full-field pattern.
- Power on the specific degausser and face it to the TV screen.
- Turn on the degausser. Slowly move it around the screen and slowly take it away from the TV.
- Repeat the above steps until the TV is degaussed completely.

2.2.2 Confirmation and Adjustment for Voltage

Caution: +B voltage has close relation to high voltage. To prevent X-ray radiation, set +B voltage to the rated value. The maximal radiator is not GND by reason of linking to TP--12V.

- Make sure that the supply voltage is within the range of the rated value.
- Connect a digital voltmeter to the voltage output terminal of the main PCB. Power on the TV and set the brightness and sub-brightness to minimum. Ensure that the voltage from the main PCB reads as follows.
- Regulate voltage adjustment components on the power section until the +B the voltage reaches the rated value.

Test Point	Voltage	Note
TP-310V	311 ± 5V	This value will vary as different power supply.
TP-103V	104 ± 1.5V	
TP-184V	184 ± 3V	

TP-+12V	13 ± 1V or 16 ± 1V	This value will vary as different CRT.
TP--12V	-13 ± 1V or -16 ± 1V	This value will vary as different CRT.
TP-22V	22 ± 1V	
TP-35V	35 ± 1V	
TP-36V	36 ± 1V	
TP-5V-1	5 ± 0.3V	
TP-8V	8 ± 0.3V	
TP-5V-2V	5 ± 0.3V	
TP-3.3V	3.3 ± 0.3V	

Note: It's impossible to check the power part separately from the main chassis board as the part is mounted on the main chassis board. The power components, etc. should be checked for burnout when power-on. If burned out, do not power on the TV again until the cause is found out.

2.2.3 High Voltage Inspection

Measure voltages of test points on the main PCB with the digital voltmeter. Measure the CRT high voltage with the high-voltage testing equipment and heater voltage with the high-frequency effective voltmeter. The rated values are shown as below.

Test Point	Voltage	Test Point	Voltage
Negative of VD491	184±3V	14"GS_CRT_anode	22±1.5KV
21 "FS_CRT_anode	25.5±1.5KV	21 "PF-CRT-anode	26.5±1.5KV
21"US CRT anode (HUAFEI)	25.5±1.5KV	21"US /SS CRT anode (SAMSUNG)	23.5±1.5KV
21"SS CRT anode (LG)	26±1.5KV	Heater	6.3±0.3Vrms

2.2.4 . Lian grid, focuse of the adjustment and white balance adjust

Caution: Dangerously high voltages are present inside the TV. Extreme caution should be exercised when working on the TV with the back removed.

- (1) Power on the TV and preheat it for 15 min.
- (2) Press P.MODE key to select NATURE mode.
- (3) Counterclockwise to adjust the Lian grid to the least.
- (4) Enter the service mode and select VSD, clockwise adjust the Lian grid , adjust to the screen to at

the right moment appear a horizon. Adjust Lian grid, make the horizon accommodation(not dazzling, white, if it doesn't white repeated step until white)

- (5) Change parameter(BLOR, BLOG , BLOB, WPR, WPG, WPB) to adjust white balance in service mode.
- (6) Regulate to focus , make the light grid focuse good,and you get a sharp picture.

2.25 SERVICE mode

To enter the SERVICE mode

Set the volume to 0,hold the MUTE button on the remote control, and press the MENU button on the TV to enter the SERVICE mode. To exit from the SERVICE mode, turn off the TV set by the POWER button on the remote control.

Caution: The user service mode adjustment can be changed only when service personnel adjust the whole set data during servicing. As the control data have dramatic effects on functions and performance of the TV,service personnel should not tell user how to enter the SERVICE mode to avoid improper data settings.

Adjustments and bus data

Symbol	Description	Data
Page 0	The OTP Software NO Displayed As: GDET03**-**	
V-Bri	Pic Brightness Displayed	32
VSD	Vertical Scan Disable	32
Page 1	G-0 When Vertical Frequency is Identified as 50Hz,Then 50Hz will be displayed; so is 60Hz.	
HSH	Horizontal Shift	32/38 (Adjust to the best)
HPAR	Horizontal Parallelogram Correction	26/28 (Adjust to the best)
HBOW	Horizontal BOW Correction	32/32 (Adjust to the best)
VLIN	Vertical Linearity	32/32 (Adjust to the best)
VSCR	Vertical Scroll	32/32
<i>EWV</i>	<i>E-W Width</i>	53/51 (Adjust to the best)
<i>PW</i>	<i>E-W Parabola Width</i>	22/18 (Adjust to the best)
Page 3	G-2	
<i>UCP</i>	<i>E-W Upper Corner Parabola</i>	46/37 (Adjust to the best)
<i>LCP</i>	<i>E-W Bottom Corner Parabola</i>	42/33 (Adjust to the best)
<i>TC</i>	<i>E-W Trapezium</i>	32/32 (Adjust to the best)
VSH	Vertical Shift	36/36 (Adjust to the best)
VA	Vertical Amplitude	22/22 (Adjust to the best)
SC	Vertical S Correction	32/24 (Adjust to the best)

VSL	Vertical Slope	32/31 (Adjust to the best)
Page 3	G-2	
ZOOM 16	Vertical zoom 16: 9	0
ZOOM N	Vertical zoom normal 4: 3	25
ZOOM EX	Vertical zoom expand zoom	51
OSD-V5	50Hz OSD VERTICAL SHIFT	50 (Adjust to the best)
OSD-V6	60Hz OSD VERTICAL SHIFT	46 (Adjust to the best)
Fac	Factory Bus open	0
Init	EEPROM init	0
Page 4	W-tone	
BLOC	Common course black level offset	7
BLOR	Fine black level offset R	32 (Adjust to the best)
BLOG	Fine black level offset G	32 (Adjust to the best)
BLOB	Fine black level offset B	32 (Adjust to the best)
WPR	White point R	32 (Adjust to the best)
WPG	White point G	32 (Adjust to the best)
WPB	White point B	32 (Adjust to the best)
Page 5	Tuning	
IF	IF selection	3
TOP		20 (Adjust to the best)
AGCS	IF AGC SPEED	1
OIF	Off-set if demodulatour	32
T-SET	Teletext language	
TXT-H-POS	The horizontal position of teletext	10(Adjust to the best)
TXT RGB	The brightness of teletext	15(Adjust to the best)
Page 6	SYS	
NTSC		1
SECAM		1
BG-A2		0
M		1
L		0
O-SYS		2
O-LANG		1
Page 7	MENU	
AVLE	AVL/EW function select	0
AVL	AVL function	0
DEG	DEGAUSS	0
B-TRE	Sound effect	0

DISG	Gain selection of DISCO	0
COF	Cut-off control range	0
DCXO	Crystal Frequency Correcting Compensation	2
Page 8	OTHER	
S-VIDEO	S-VIDEO Set	0
M-ON	Memory on	1
OFF-TIME	Auot off without signal. 0:5 Minutes; 1:10 Minutes; 2: 15Minutes	0
LOGO-ACT	User's logo setup	1
NO-SIG	Have no signal to hint	1
LOG0	Logo color 0	1
LOG1	Logo color 1	6
Page 9	SUB	
S-BRI	Sub bright	0
M-BRI	Max bright	63
S-CON	Sub contrast	0
M-CON	Max contrast	63
MX-COL	Max color	63
LOG-T	LOGO Selection	0
VX-VAM		0/1
Page 10	Video-0	
PWLDAC		15
COR-DEF	Noise Reducing	1
SSL	Slicing level	0
FSL	Forced slicing level for vertical sync	0
AAS	Black area to switch off the black stretch	2
XDT	X-ray detection	0
Page 11	Audio-0	
AMLOW	Audio output signal for AM sound/AM	0
GSSIF	Extra gain-range SSIF for AM demodulation	0
DSG	Gain from audio inputs to audio outputs	0
AGN	Gain FM demodulator	0
AGNE	Extended gain settings for FM demodulator	1
Page 12	Audio-1	
T.mod	EHT Compensation Set	1
FMWS	Window select for FM demodulator	1
BPB2	Bypass sound bandpass filter section 2	1
FFI	Fast filter IF-PLL	1

Page 13	Video-1	
CL	Cathode drive level	12
SOC	Soft clipping level	2
CHSE	PAL/NTSC ident sensitivity (burst amplitude at strong signal (typical value)	2
CLO	Centre frequency of cloche filter	1
<i>HBL</i>		<i>1</i>
<i>WBF</i>		<i>0</i>
<i>WBR</i>		<i>8</i>

Notes: The data sheet may differ dependent on different models. The data sheet may differ dependent on different CRTs for the same model.

STRUCTURE AND CHISSIS FUNCTION DESCRIPION

3.1 STRUCTUE BLOCK DIAGRAM

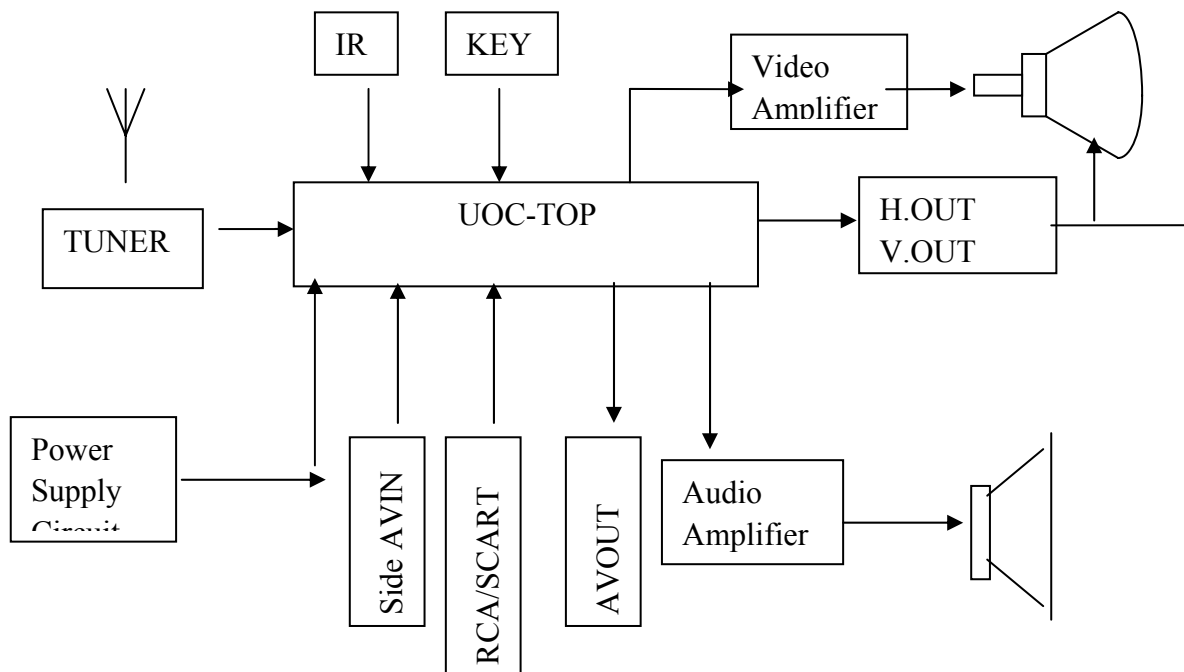

3.2 CHASSIS DESCRIPTION

3.2.1 General Description

ETE-3 chassis is applied in SS21GG300A series. By use of Philips UOC-TOP for TV small signal processing and bus control, the chassis enables TV tuning, adjustment, control and picture correction, featuring high-integration, high-performance-to-price ratio and high-reliability and compact circuit with fewer external components. The chassis, widely used in small and medium

TVs, provides much more convenience for manufacturing and technical service. It includes:
 UOC TDA11136PS/N3/3 for PAL/NTSC /SECAM small signal processing and bus control
 EEPROM AT24C16 for data memory, TDA4864AJ for vertical output power amplifying,
 TFA9842AJ for audio power amplifying ,Thick-film IC FSCQ0765RT for power circuit
 adjustment and control.

3.2.2 The following features are available in the chassis:

Color systems: PAL, SECAM (OPT), NTSC(OPT)

Sound systems: D/K, B/G, I , M(OPT)

Other:236 programs preset ,AV stereo, Hotel , Child lock , Teletext (OPT) ,ZOOM, Channel
 swap,Recall,Timer.

3.2.3 The chassis mainly uses the following ICs and assemblies.

	Position	Type	Description
1	N201	AT24C16	EERPOM
2	N202	TDA111XXPS	Micro processor,MONO-90 /MONO110 Versions for 90°/110° picture tubes
		TDA121XXPS	Micro processor,AV -90/AV-110 Versions for 90°/110° picture tubes
3	N601	TFA9842AJ	Audio power amplifier
4	N300	TDA4864AJ/TDA4863AJ	
		TDA4865AJ	For Ultra-slim CRT
5	N801	FSCQ0765	Switch-mode power supply control
6	A001	TAF5-C4I23 etc.	38MHz IF tuner,to Asia
		TAF5-E4I22 etc.	38.9MHz IF tuner,to Europe

4. SERVICE DATA

4.1 TV signal processor TDA111XX/TDA121XX series

4.1.1 GENERAL DESCRIPTION

The various versions of the TDA111XX /TDA121XX series combine the functions of a video
 processor together with a -Controller and US Closed Caption decoder. Most versions have a
 Teletext decoder on board. The Teletext decoder has an internal RAM memory for 1 page text. The

ICs are intended to be used in economy television receivers with 90 and 110 picture tubes. The ICs have supply voltages of 8 V and 3.3 V and they are mounted in an SDIP-64 envelope.

The features are given in the following feature list.

4.1.2 FEATURES TV processor

Available in TDA111XX versions

- Multi-standard vision IF circuit with alignment-free PLL demodulator
- Internal (switchable) time-constant for the IF-AGC circuit
- The mono intercarrier sound circuit has a selective FM-PLL demodulator which can be switched to the different FM sound frequencies (4.5/5.5/6.0/6.5 MHz). The quality of this system is such that the external band-pass filters can be omitted.
- The FM-PLL demodulator can be set to centre frequencies of 4.72/5.74 MHz so that a second sound channel can be demodulated. In such an application it is necessary that an external band pass filter is inserted.
- Integrated chrominance trap circuit
- Integrated luminance delay line with adjustable delay time
- Picture improvement features with peaking (with switchable centre frequency, depeaking, variable positive/negative overshoot ratio and video dependent coring) and blue- and black stretching.
All features are available for CVBS, Y/C and YPBPR signals.
- Tint control for external RGB/YP_BP_R signals
- Integrated chroma band-pass filter with switchable centre frequency
- Only one reference (12 MHz) crystal required for the -Controller, Teletext- and the colour decoder
- Multi-standard colour decoder with automatic search system
- Internal base-band delay line
- Indication of the Signal-to-Noise ratio of the incoming CVBS signal
- A linear RGB/YUV/YPBPR input with fast blanking for external RGB/YUV sources. The synchronisation circuit can be connected to the incoming Y signal. The Text/OSD signals are internally supplied from the -Controller/Teletext decoder.
- RGB control circuit with 'Continuous Cathode Calibration', white point and black level off-set adjustment so that the colour temperature of the dark and the light parts of the screen can be chosen independently.
- 2 levels of contrast reduction of main picture possible during OSD/Text insertion ('halftone')
- OSD/Text gain reduction control
- Adjustable 'wide blanking' of the RGB outputs
- Horizontal synchronization with two control loops and alignment-free horizontal oscillator
- Vertical count-down circuit

- Vertical driver optimized for DC-coupled vertical output stages
- Horizontal and vertical geometry processing
- Horizontal and vertical zoom function for 16:9 applications
- Horizontal parallelogram and bow correction for large screen picture tubes
- Low-power start-up of the horizontal drive circuit
- Macrovision keying possibility for horizontal synchronisation.

Available in TDA111XX versions

- A choice can be made between versions with mono intercarrier sound FM demodulator and versions with QSS IF amplifier.
- Source selection between the ‘internal’ CVBS and an external CVBS or Y/C signal

Controller

- 80C51 μ -controller core standard instruction set and timing
- 0.9766 μ s machine cycle
- maximum of 64 k x 8-bit late programmed ROM
- maximum of 3 k x 8-bit Auxiliary RAM (2 k required for Display)
- I2C byte level bus interface.
- Interrupt controller for individual enable/disable with two level priority
- Two 16-bit Timer/Counter registers
- One 24-bit Timer (16-bit timer with 8-bit Pre-scaler)
- 16-bit Data pointer
- WatchDog timer
- Auxiliary RAM page pointer
- Stand-by, Idle and Power Down modes
- Up to 13 general-purpose I/O pins
- 14 bits PWM for Voltage Synthesis Tuning
- 8-bit A/D converter with 4 multiplexed inputs
- 4 PWM (6-bits) outputs for analogue control functions

Data Capture

- Text memory for 1 page
- Inventory of transmitted Teletext pages stored in the Transmitted Page Table (TPT) and Subtitle Page Table (SPT)
- Data Capture for US Closed Caption
- Data Capture for 525/625 line WST, VPS (PDC system A) and 625 line Wide Screen Signalling (WSS) bit decoding

- Automatic selection between 525 WST/625 WST
- Automatic selection between 625 WST/VPS on line 16 of VBI
- Real-time capture and decoding for WST Teletext in Hardware, to enable optimized -processor throughput
- Automatic detection of FASTEXT transmission
- Real-time packet 26 engine in Hardware for processing accented,G2 and G3 characters
- Signal quality detector for video and WST/VPS data types
- Comprehensive teletext language coverage
- Full Field and Vertical Blanking Interval (VBI) data capture of WST data

Display

- Up to 4 character sets with 256 characters each (size 16 pixels x 18 lines)
- Enhanced OSD modes
- 50Hz/60Hz display timing modes
- Serial and Parallel Display Attributes
- Single/Double/Quadruple Width and Height for characters
- Scrolling of display region
 - Variable flash rate controlled by software
 - Enhanced display features including overlining, underlining and italics
- Soft colours using CLUT with 4096 colour palette
- Global selectable matrix: (12/16)
- Fringe colour selectable
- Contrast reduction of defined area
- Programmable Cursor
- Special Graphics Characters with two planes, allowing four colours per character

4.2 TFA9842AJ

2-channel audio amplifier with volume control (SE: 1 W to 7.5 W)

4.2.1 General description

The TFA9842AJ contains two identical audio power amplifiers. The TFA9842AJ can be used as two Single-Ended (SE) channels with a volume control. The maximum gain is 26 dB. The TFA9842AJ comes in a 9-pin DIL-bent-SIL (DBS9P) power package. The TFA9842AJ contains a unique protection circuit that is solely based on multiple temperature measurements inside the chip. This gives maximum output power for all supply voltages and load conditions with no unnecessary audio holes. Almost any

supply voltage and load impedance combination can be made as long as thermal boundary conditions (number of channels used, external heatsink and ambient temperature) allow it.

4.2.2 Features

2 Channel SE: 1 W to 7.5 W operation possibility

Soft clipping

Input clamps

Volume control

Standby and mute mode

No on/off switching plops

Low standby current

High supply voltage ripple rejection

Outputs short-circuit protected to ground, supply and across the load

Thermally protected

4.2.3 Block diagram and pinning of TFA9842AJ

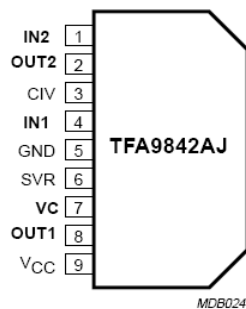
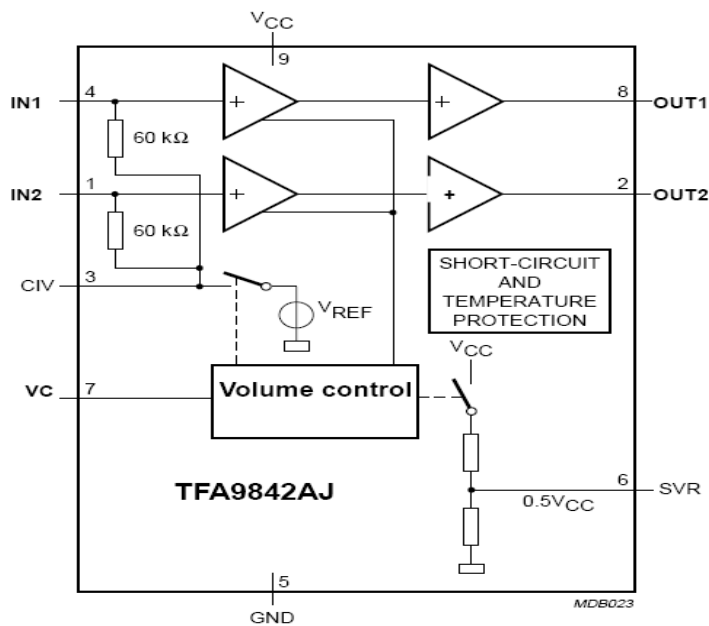

4.2.4 Pin Description

2	VP3	flyback generator output
3	VP2	supply voltage 2 for vertical output
4	GND	ground or negative supply voltage
5	V-OUT	vertical output
6	INN	inverted input of differential input stage
7	INP	non-inverted input of differential input stage

4.4 EEPROM AT24C16

4.4.1 Features

Data EEPROM internally organized as 1024/2048 bytes and 64/128 pages×16 bytes

Page protection mode, flexible page-by-page hardware write protection -Additional protection EEPROM of 64/128 bits, bit per data page 1-Protection setting for each data page by writing its protection bit -Protection management without switching WP pin

Low power CMOS

V_{cc}=2.7 to 5.5V operation

Two wire serial interface bus, IIC-Bus compatible

Filtered inputs for noise suppression with Schmitt trigger

Clock frequency up to 400 kHz

High programming flexibility

- Internal programming voltage
- Self timed programming cycle including erase
- Byte-write and page-write programming, between 1 and 16 bytes
- Typical programming time 6ms(< 10ms) for up to 16 bytes

High reliability

- Endurance 10⁶ cycles 1)
- Data retention 40 years 1)
- ESD protection 4000 V on all pins

8 pin DIP/DSO packages

Available for extended temperature ranges

- Industrial: -40to +85
- Automotive: -40to +125

4.4.2 Pin Description

SERIAL CLOCK (SCL): The SCL input is used to positive edge clock data into each EEPROM

device and negative edge clock data out of each device.

SERIAL DATA (SDA): The SDA pin is bi-directional for serial data transfer. This pin is open-drain driven and may be wire-ORed with any number of other open-drain or open-collector devices.

The AT24C08 only uses the A2 input for hardwire addressing and a total of two 8K devices may be addressed on a single bus system. The A0 and A1 pins are no connects.

4.4.3 Memory Organization

T24C16, 16K SERIAL EEPROM: Internally organized with 64 pages of 16 bytes each, the 16K requires a 10-bit data word address for random word addressing.

4.4.4 Block Diagram

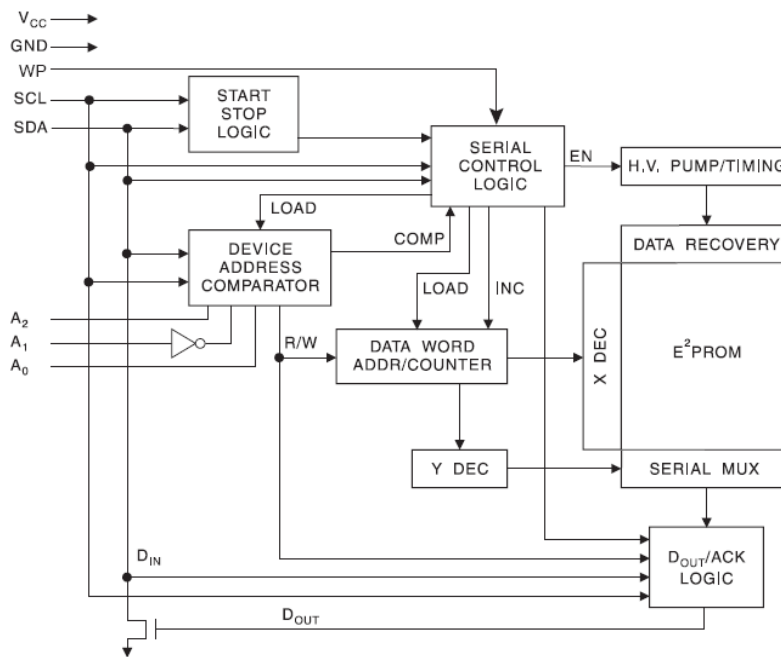

4.5 SWITCH-MODE POWER SUPPLY IC FSCQ0765RT

Pin Number	Pin Name	Pin Function Description
1	Drain	High voltage power SenseFET drain connection.
2	GND	This pin is the control ground and the SenseFET source.
3	V _{cc}	This pin is the positive supply input. This pin provides internal operating current for both start-up and steady-state operation.
4	V _{fb}	This pin is internally connected to the inverting input of the PWM comparator. The collector of an opto-coupler is typically tied to this pin. For stable operation, a capacitor should be placed between this pin and GND. If the voltage of this pin reaches 7.5V, the over load protection triggers, which results in the FPS shutting

		down.
5	Sync	This pin is internally connected to the sync detect comparator for quasi-resonant switching. In normal quasi-resonant operation, the threshold of the sync comparator is 4.6V/2.6V. Whereas, the sync threshold is changed to 3.0V/1.8V in an extended quasi-resonant operation.

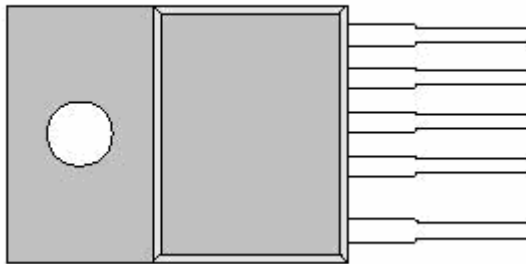
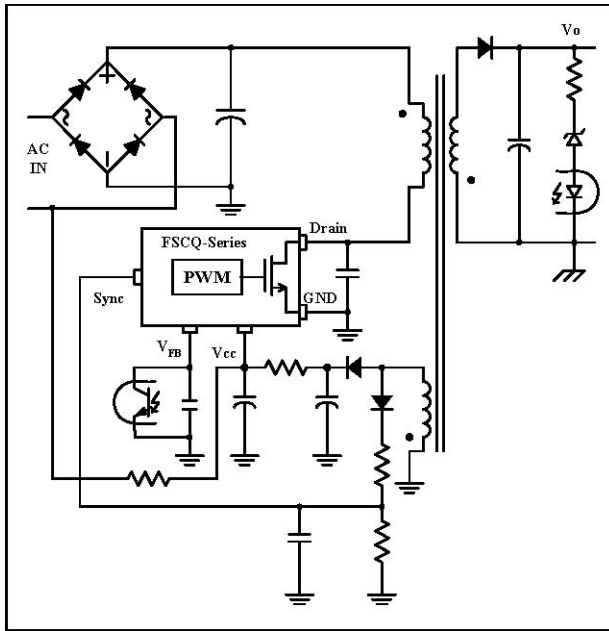

- 5.Sync
- 4.Vfb
- 3.Vcc
- 2.GND
- 1.Drain

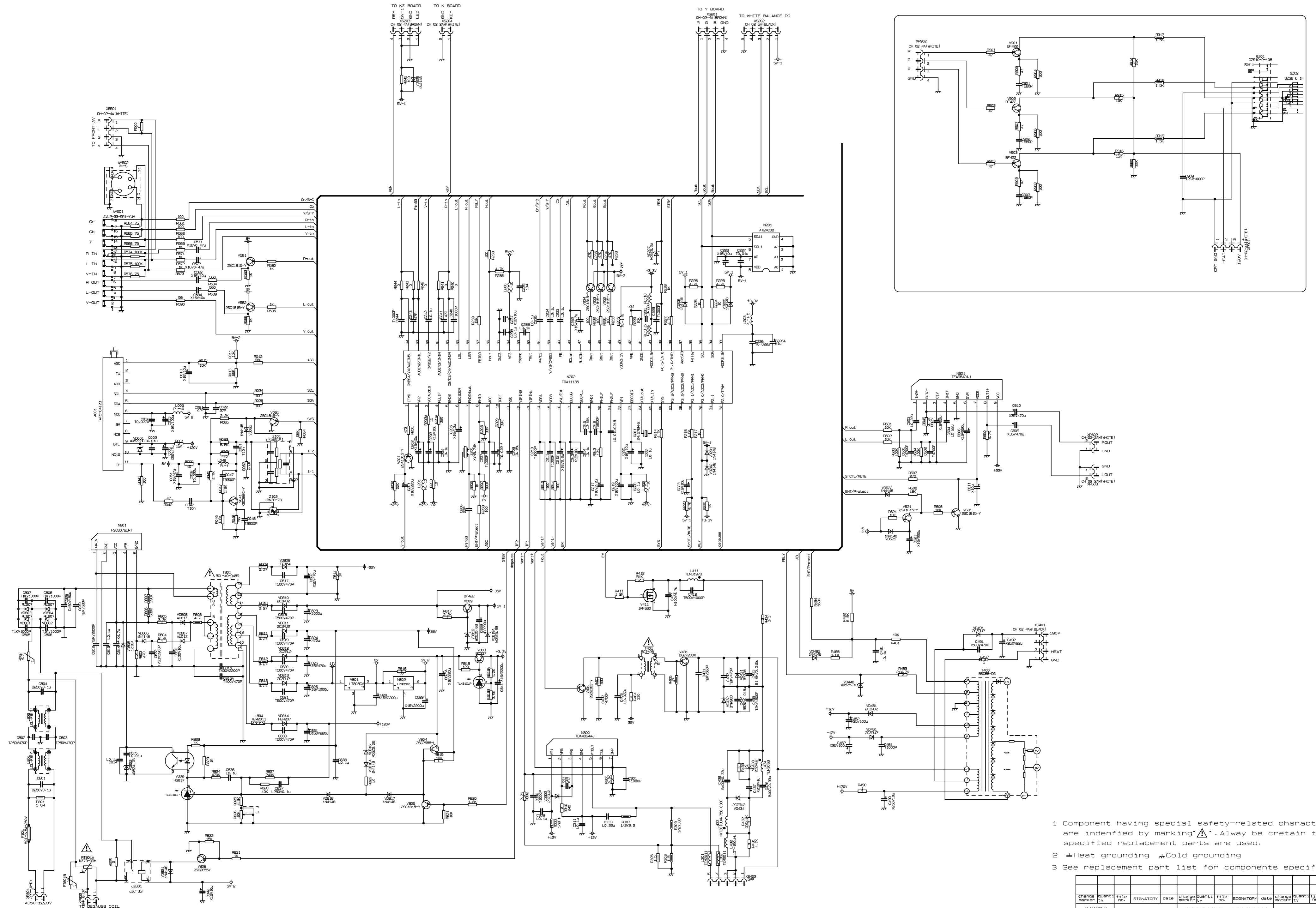

- Component having special safety-related characteristics are identified by marking Δ . Always be certain that the specified replacement parts are used.
- Heat grounding $\#$ Cold grounding
- See replacement part list for components specifications.

This circuit diagram is only for reference. Specifications are subject to change without notice.

change marker	quantity	file no.	SIGNATORY	date	change marker	quantity	file no.	SIGNATORY	date	change marker	quantity	file no.	SIGNATORY	date
DESIGNER														
AUDITOR														
TECHNOLOGIST														
NORMALIZER														
RATIFIER														

CIRCUIT DIAGRAM OF



