

# Tornado<sup>2</sup>

*Remote Controlled  
Vehicle Security System*

## Installation Manual



## Table of Contents

<b>Required Installation Tools</b> . . . . .	<b>2</b>
<b>Important Information</b> . . . . .	<b>2</b>
<b>Wiring Diagram</b> . . . . .	<b>3</b>
11 Pin Connector . . . . .	4
2 Pin Connector . . . . .	4
<b>Installation Procedures</b> . . . . .	<b>5</b>
Control Unit . . . . .	5
Antenna . . . . .	5
Wireloom . . . . .	5
Valet Switch . . . . .	5
LED Indicator . . . . .	6
Ignition Input . . . . .	6
Channel 2 Accessory Output . . . . .	6
Parking Light Output . . . . .	6
Interior Light Trigger . . . . .	7
Optional Interior Light Illumination Output . . . . .	7
Starter Disable Output . . . . .	7
Door Lock/Unlock Outputs . . . . .	8
Hood/Trunk Pin Switch . . . . .	8
Siren . . . . .	8
Power and Ground Connections . . . . .	8
Door Lock Diagrams . . . . .	9-11
<b>Programming Alarm System Features</b> . . . . .	<b>12</b>
Programming Table for Alarm Features . . . . .	12
<b>Programming Your Remote Controls</b> . . . . .	<b>13</b>
Programming Table for Remote Controls . . . . .	13

---

## **Required Installation Tools**

Voltmeter  
Wire Strippers  
Electric Drill & Bits  
Phillips Screw Driver  
Convolute Tubing \*  
Solder Gun \*  
Wire Crimpers  
Shrink Tube or Electrical Tape

\* *Optional*

---

## **Important Information**

1. Test all circuits with a voltmeter.
2. Make all wiring connections with butt connectors. DO NOT twist wires or use "scotch-lok" connectors.
3. Route RED, RED/WHITE and BLACK wires from the control unit directly to the battery.
4. Keep extensions as short as possible. Use same gauge wires for short extensions and larger gauge wires for longer extensions.
5. Before installing, discuss the placement of the LED indicator and valet switch with the vehicle owner. DO NOT disconnect the battery cables.
6. Make all connections by removing the lug from the cable clamp without detaching clamp.
7. Turn off dome light or remove dome light fuse to prevent battery drain.

***This device complies with Part 15 of the FCC rules. Any changes or modifications made to the system without the express approval of Avital Technologies, Inc. could void the user's authority to operate this equipment.***

## Wiring Diagram

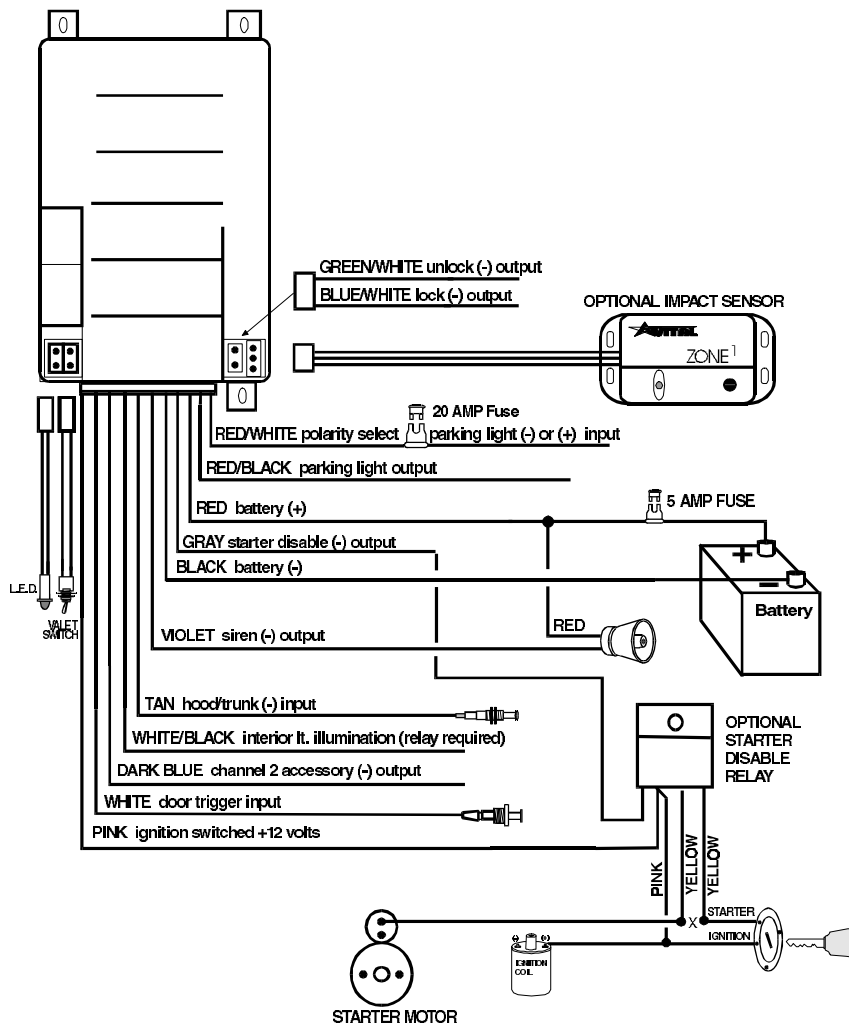

### **11 Pin Connector**

<b>Wire color</b>	<b>Description</b>
Red/Black	Parking Light Output
Red	Battery (+)
Gray	(-) Armed Output for Optional Starter Disable Relay
Black	Battery (-)
Violet	Siren (-) Output
Tan	Hood/Trunk (-) Input
White/Black	Interior Light Illumination (-) Output/Requires Optional Relay
Dark Blue	Channel 2 (-) Accessory Output
White	Door Trigger Input (+) or (-)
Pink	Ignition Switched +12 Volt Input
Red/White	Parking Light Polarity Select (+) (-)

### **2 Pin Connector**

<b>Wire color</b>	<b>Description</b>
Blue/White	(-) Door Lock Output
Green/White	(-) Door Unlock Output

---

## ***Installation Procedures***

### ***Control Unit***

1. Select a location under the dash that will allow you to use tie wraps to securely fasten the control unit.
2. Mount the control unit as high as possible to ensure maximum range.
3. Do not mount the control unit near moving parts.
4. Avoid areas that are in the direct path of air blowing from the vents.
5. Route wires from this point, leaving slack for ease of service.

### ***Antenna***

1. Do not shorten or lengthen the antenna.
2. Route the antenna away from the control unit.
3. Keep the antenna as far away from metal and wire harnesses as possible to optimize range.

### ***Wireloom***

1. Plug the wireloom securely into the control unit.
2. Route wires from the control unit directly to each connection point.
3. Separate the RED, BLACK, RED/WHITE, VIOLET and TAN wires.
4. Sleeve the wires with vinyl tubing or electrical tape and route them through an existing rubber grommet into the engine compartment.
5. If an existing grommet is not available, drill a hole and install a snap grommet.

### ***Valet Switch***

1. Discuss placement with the owner.
2. Choose a location for the valet switch that is hidden, but convenient for the owner to access.
3. Drill a ¼" hole and mount the switch.
4. Route the valet switch wires to the control unit.
5. Plug the valet switch BLUE connector into the control unit BLUE plug.

### ***LED Indicator***

1. Discuss placement with the owner.
2. Choose a location that is visible from both sides of the vehicle.
3. Drill a ¼" hole.
4. Route the LED wires through the hole and press LED into place.
5. Route the LED wires to the control unit.
6. Plug the RED LED connector into the control unit RED plug.

### ***Ignition Input***

1. Use a voltmeter to locate the one wire that shows +12 volts when the ignition key is in the "ON," "CRANK" and "RUN" position, and 0 volts when the ignition key is in the "OFF" position.
2. Connect the control unit PINK wire to the vehicle's ignition wire.

### ***Channel 2 Accessory Output***

The DARK BLUE wire provides a 0.75 second ground (-) output when the remote control button #2 is activated for 1-2 seconds. If the remote control button #2 is continuously pressed, the signal will stay at ground as long as the button is held. Most trunk releases are positive and require an optional relay.

### ***Parking Lights***

1. If the parking lights are positive trigger, connect the RED/WHITE wire to the battery positive (+) terminal through the 20 amp fuse.

***NOTE: Do not connect the RED/WHITE wire to the control unit RED wire.***

2. If the parking lights are negative (-) trigger, connect the RED/WHITE wire to control unit BLACK wire.
3. Connect the RED/BLACK wire to the vehicle parking light wire.

### ***Interior Light Trigger***

The Tornado<sup>2</sup> interior light trigger wire is programmable to accept a positive (+) or negative (-) input. The module is factory preset for negative (-) door trigger.

1. Connect the alarm WHITE wire to the vehicle door trigger wire(s).
2. If the vehicle door trigger is positive (+) trigger, follow the "Door Trigger Input Polarity" section in the "Programming Table for Alarm Features" to program the module for positive (+) door trigger.

### ***Interior Light Illumination Output***

The WHITE/BLACK wire provides a current limited (-) output for 30 seconds upon remote disarm. ***Interior light illumination requires an optional relay.***

1. Connect the alarm WHITE/BLACK wire to relay terminal 85.
2. Connect relay terminal 86 to a fused constant +12 volt source.
3. Connect relay terminal 30 to the vehicle door trigger wire(s).
4. If the vehicle door trigger is positive (+) trigger, connect relay terminal 87 to a fused +12 volt source.
5. If the vehicle door trigger is negative (-) trigger, connect relay terminal 87 to ground (-).

### ***Starter Disable Output***

The alarm GRAY wire provides a continual ground output while the alarm is armed. ***Starter disable requires an optional 30 amp relay.***

1. Connect the alarm GRAY wire to relay terminal 85.
2. Connect relay terminal 86 to an ignition switched +12 volt source (alarm module PINK wire).
3. Locate the ignition switch wireloom under the dashboard.
4. Use a voltmeter to find the one wire that will show +12 volts while the ignition key is in the cranking cycle only. This should be the starter solenoid wire.
5. Cut the starter solenoid wire in half. Test by trying to crank the starter. If it will not crank, you have the correct wire.
6. Connect one end of the starter wire to relay terminal 87A.
7. Connect the other end of the starter wire to relay terminal 30.

### ***Door Lock/Unlock Outputs***



The alarm provides a .75 second 300 MA (-) output for lock and unlock. Follow the door lock diagrams on pages 9 - 11.

### **Hood/Trunk Pin Switch**

1. Locate the vehicle hood or trunk pin switch that shows ground when the hood or trunk is open only.
2. Connect the alarm module to the vehicle hood or trunk switch wire.
3. If the vehicle does not have a hood or trunk switch, install an alarm pin switch and connect it to the alarm module TAN wire.

### **Siren**

1. Choose a location in the engine compartment away from high heat engine components, moving parts and direct exposure to water.
2. Make sure the siren and siren wires cannot be seen or reached from below the vehicle.
3. Mount the siren with the two self tapping screws to a solid metal surface.
4. Connect the siren BLACK wire to the alarm module VIOLET wire.
5. Connect the siren RED wire to the alarm module RED wire.

### **Power and Ground Connections**

**Caution: Do not plug in the system fuses until the final step below.**

1. Connect the alarm RED wire to one of the supplied fuse assemblies.
2. Connect the alarm RED/WHITE wire to the other fuse assembly (if the vehicle parking lights are (+) positive).
3. Connect the fuse assembly(s) to one of the supplied 10mm ring terminals.
4. Connect the alarm BLACK wire to the other 10mm ring terminal.
5. Remove the (+) and (-) battery bolts. Do not disconnect the battery clamps.
6. Connect the empty fuse assembly(s) to the positive battery post.
7. Connect the alarm BLACK wire to the battery negative post.
8. Inspect all alarm wiring. Make sure all wires are connected.
9. Install the 5 amp fuse in the alarm module RED wire fuse assembly.
10. Install the 20 amp fuse in the alarm module RED/WHITE fuse assembly (if the vehicle parking lights are positive).

**Negative Trigger Door Locks**

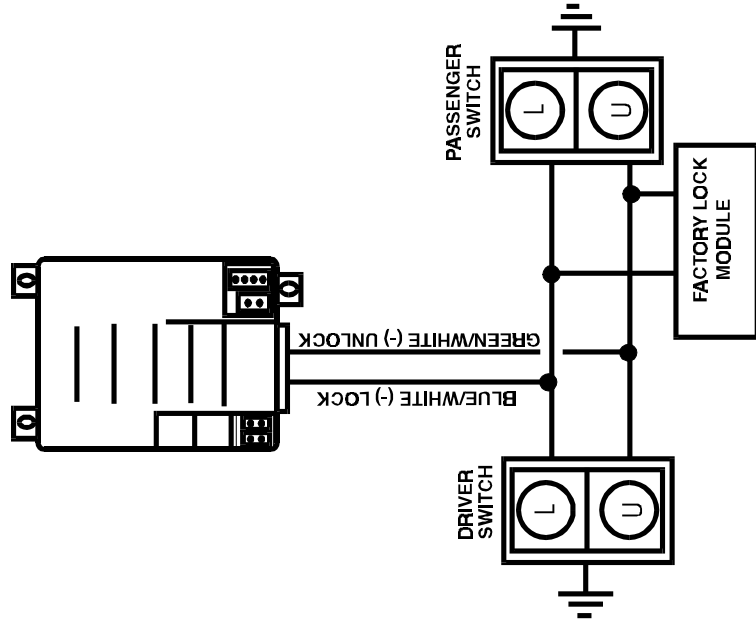

**Positive Trigger Door Locks**

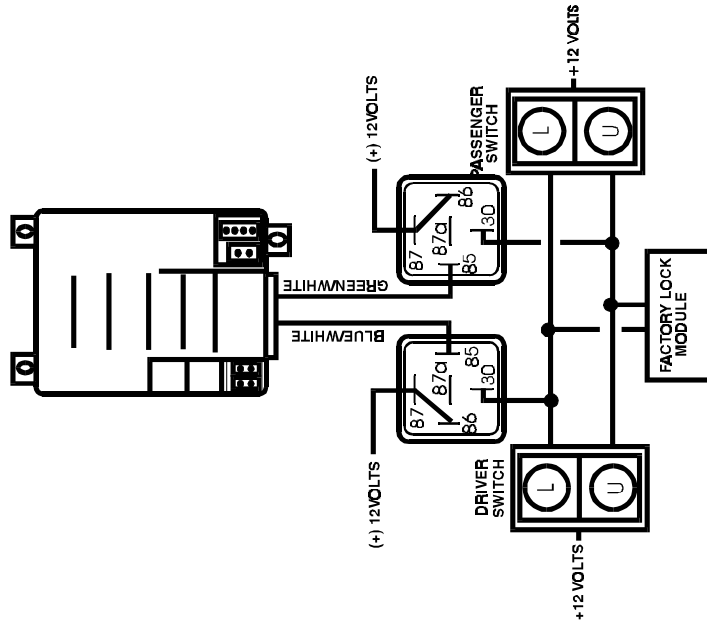

**Adding Door Lock Actuators**

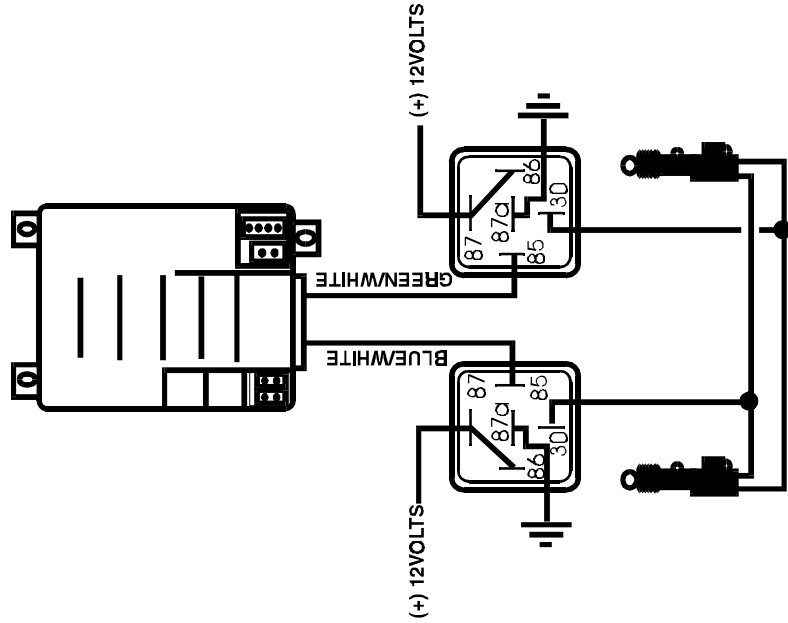

**Reverse Polarity Door Locks**

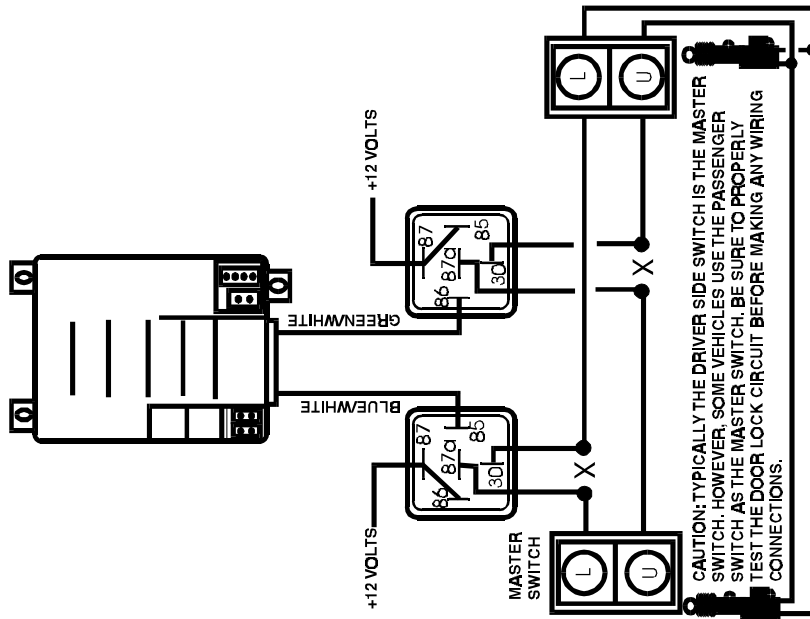

**One Wire Door Lock/Unlock**  
*(Mercedes/Audi)*

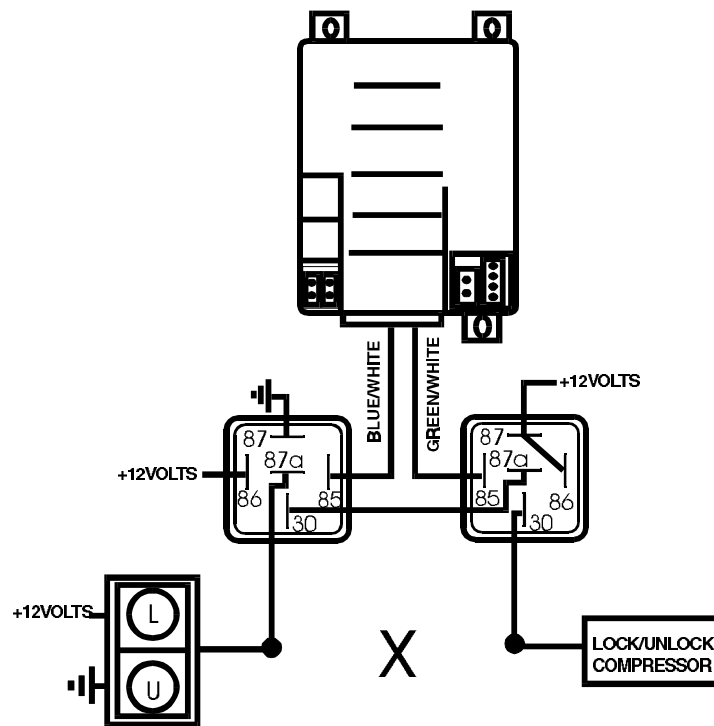

## ***Programming Alarm System Features***

All programmable alarm features are accomplished by turning the ignition key on (or starting the vehicle) and flicking the valet switch on and off a pre-set number of times.

1. Remove the alarm from valet. Programming cannot be accessed while the alarm is in the valet mode indicated by the LED on solid red.
2. Select the feature you wish to program from the "Programming Table for Alarm Features." **Note the number of chirps.**
3. Turn the ignition key to the "ON" position.
4. Within 10 seconds, begin flicking the valet switch on and off. The siren will chirp once each time you flick the switch on then off.
5. Continue flicking the switch on and off until you reach the number of chirps associated with your chosen feature.

**NOTE: Stop on the chirp.**

6. After a 3 second pause, you will hear 1 or 2 chirps noted to confirm that you have changed the setting of that feature.
7. Turn the ignition key off.
8. Repeat steps 1-7 for any other feature you wish to program.

### ***Programming Table for Alarm Features***

<b><i>Feature</i></b>	<b><i>Factory Setting</i></b>	<b><i># of Chirps</i></b>	<b><i>Secondary Action</i></b>
Passive/Active Arming	Passive ON	4	Wait 3 seconds, the siren chirps once for active or twice for passive.
Passive Door Locking	OFF	5	Wait 3 seconds, the siren chirps once for OFF or twice for ON.
Remote Arming Siren Chirps	ON	6	Wait 3 seconds, the siren chirps once for OFF or twice for ON.
Door Trigger Polarity Select	(-) Trigger	7	Wait 3 seconds, the siren chirps once for (+) trigger or twice for (-) trigger.

## Programming Your Remote Controls

The Tornado<sup>2</sup> allows you to add new remote controls in one step, delete lost or stolen remote controls or rearrange the factory preset remote control functions.

All remote control programming features are accomplished by turning the ignition key on (or starting the vehicle) and flicking the valet switch on and off a preset number of times.

1. Remove the alarm from valet. Programming cannot be accessed while the alarm is in the valet mode, indicated by the alarm LED on solid red.
2. Select the feature from the "Programming Table for Remote Controls."  
**Note the number of chirps.**
3. Turn the ignition key to the "ON" position.
4. Within 10 seconds, begin flicking the valet switch on and off. The siren will chirp one time each time you flick the switch on then off.
5. Continue flicking the valet switch on and off until you reach the number of chirps associated with your chosen feature.

**NOTE: Stop on the chirp.**

6. Follow the "Secondary Action."
7. Turn the ignition key off.
8. Repeat steps 1-7 for any other feature you wish to program.

### **Programming Table for Remote Controls**

<b>Feature</b>	<b>Factory Setting</b>	<b># of Chirps</b>	<b>Secondary Action</b>
Arm/Disarm/Remote Panic	Channel 1	8	Press any remote control button you choose to operate this feature. Siren will chirp once for confirmation.
Accessory (-) Output	Channel 2	9	Press any remote control button you choose to operate this feature. Siren will chirp twice for confirmation.
Silent Arm/Disarm	Channel 3	10	Press any remote control button you choose to operate this feature. Siren will chirp 3 times for confirmation.
All Channel Learn	—	11	Press button #1. The siren will chirp 1 time. Remote control will operate at factory preset order.
Instant Code Deletion	—	12	Wait 3 seconds. The siren will chirp twice. All remote controls are erased from memory.



© Copyright 1998 Avital Technologies, Inc.

32-3273/T2IM/98