

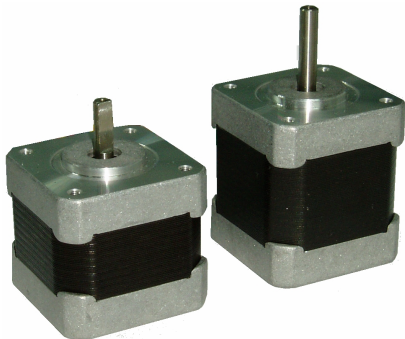

42HS Series Hybrid Stepping Motors



General Specifications

Step Angle Degree	1.8°
Step Angle Accuracy	±5%(full step, no load)
Temperature Rise	80°CMax
Ambient Temperature	-10°C — +50°C
Insulation Resistance	100MΩmin.500VDC
Dielectric Strength	500VAC for one minute
Shaft Radial Play	0.06 Max.(450g-load)
Shaft Axial Play	0.08 max.(450g-load)

Electrical Specifications

Model Number	Connection	Motor Length L inch (mm)	Holding Torque Oz-in (Nm)	Number of Leads	Phase Current (Amps)	Phase Resistance (Ohm)	Phase Inductance (mH)	Rotor Inertia Oz-in-sec ² (g.cm ²)	Detent Torque Oz-in (g.cm)	Weight Oz (kg)
42HS02	—	1.34 (40)	31.15 (0.22)	4	0.4	12.5±10%	21±20%	0.000809 (57)	2.21 (153)	8.47 (0.24)
42HS03	(Bipolar) Parallel	1.89 (48)	66.55 (0.47)	8	1.4	2.3±10%	4±20%	0.001164 (82)	2.83 (204)	11.99 (0.34)
	(Bipolar) Series				0.7	9.2±10%	16±20%			
	Unipolar				1.0	4.6±10%	4±20%			

* Above motors are our typical models, and if you need a customization motor, please contact us.

Mechanical Specifications (Unit=mm, 1 inch=25.4mm)

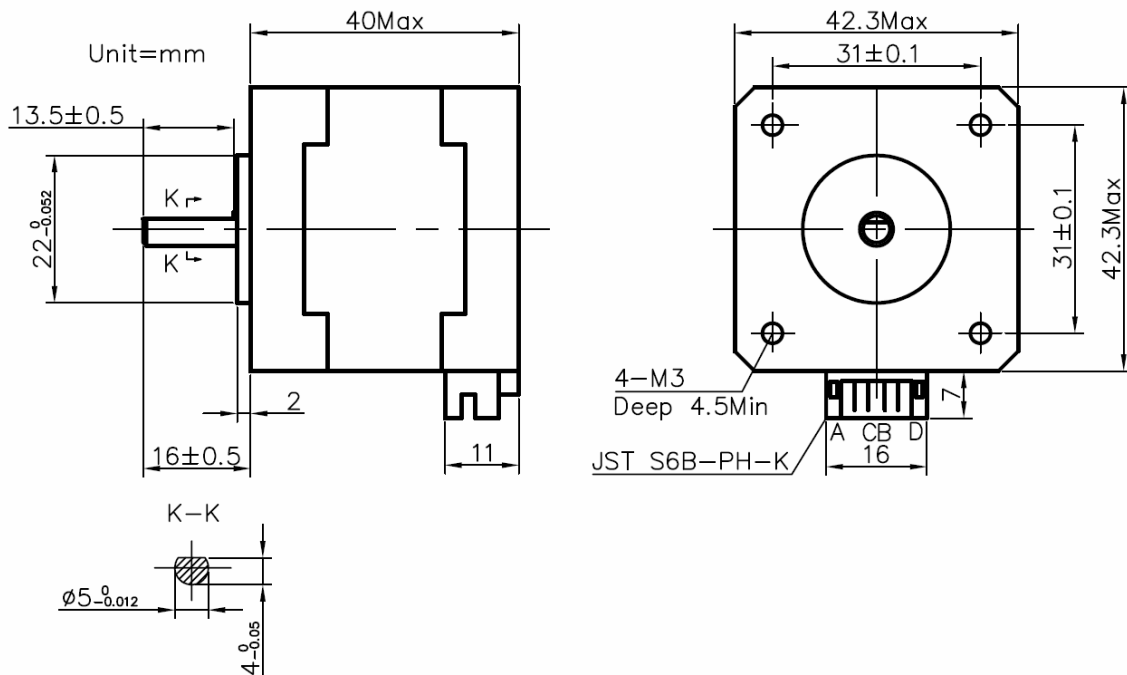

Figure 1: Mechanical specification of 42HS02

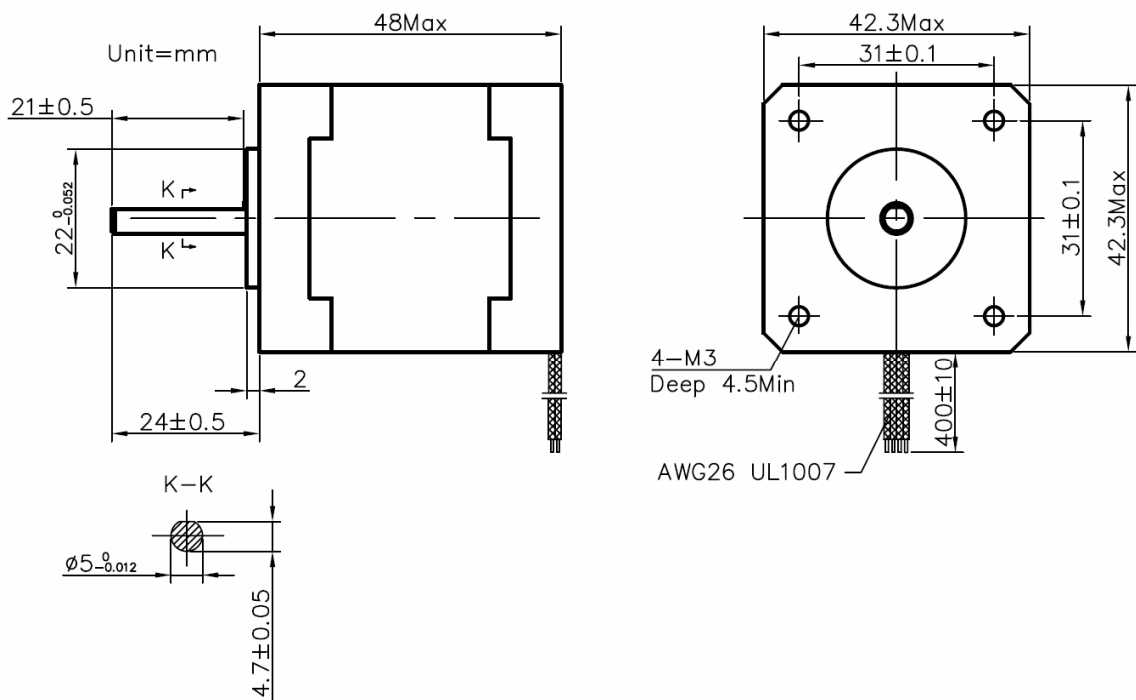

Figure 2: Mechanical specification of 42HS03

Wiring Diagrams

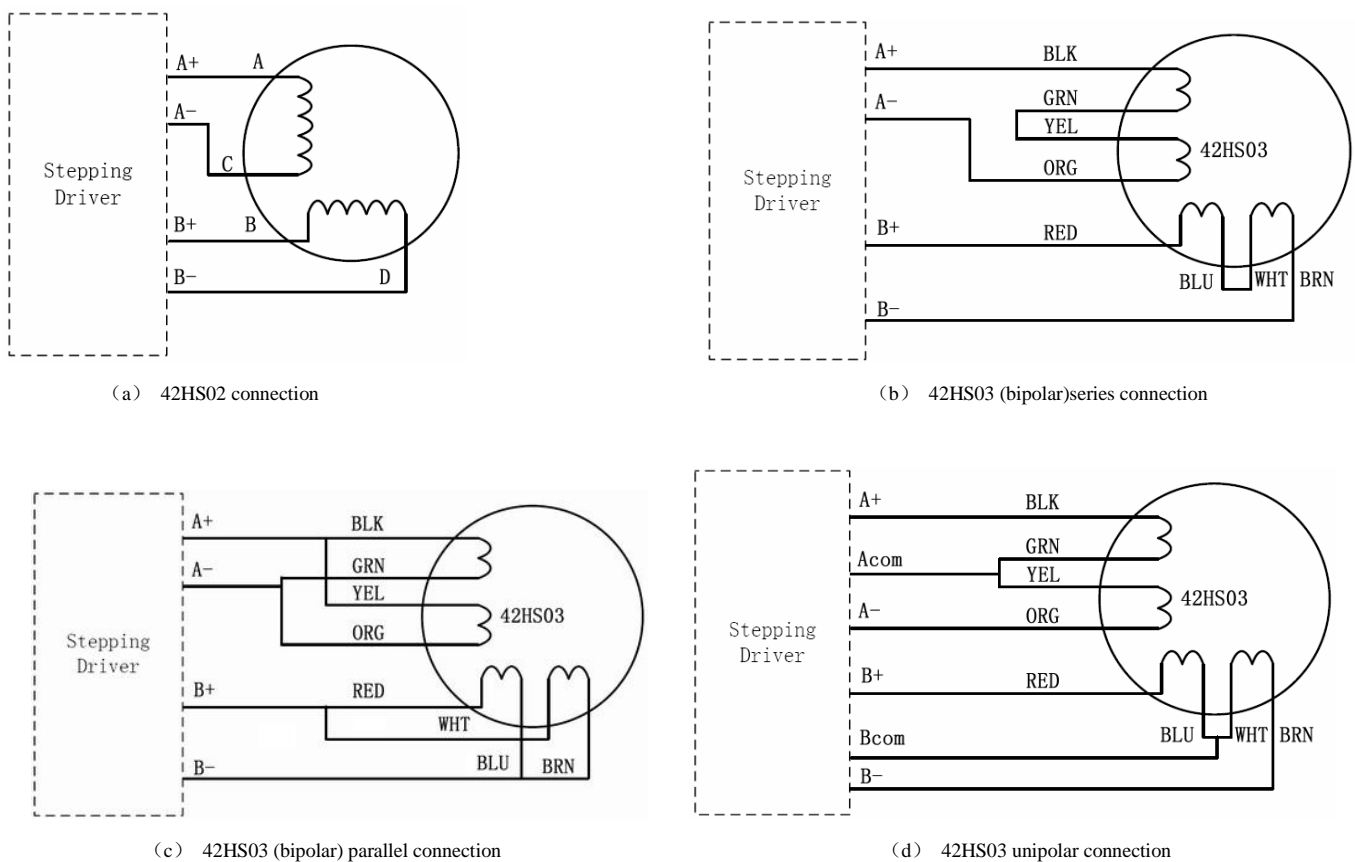

Figure 3: Wiring diagrams



Speed-Torque Characteristics

Unipolar and bipolar half coil, because we're using less turns, doesn't give us great low speed torque, but because of the low inductance, holds the torque out to high speeds. Bipolar series uses the full coil so it gives very good low speed torque. But because of the high inductance, the torque drops off rapidly. Bipolar parallel also uses the full coil so it gives good low speed performance. And its low inductance allows the torque to be held out to high speeds. But remember, we must increase current by 40% to get those advantages. Speed-torque curves show the maximum torques that can be output at a given speed. When selecting a motor, make sure the required torque falls within the particular curve.

I 42HS03

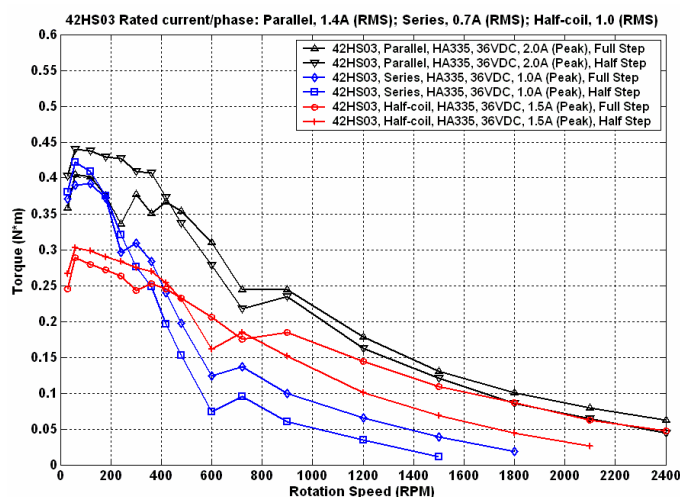

Figure 4: Speed-torque curves of the 42HS03

Remarks:

1. Title "42HS03 Rated current/phase: Parallel, 1.4A (RMS); Series, 0.7A (RMS); Half-coil, 1.0A (RMS)" means "When the 42HS03 used in parallel mode, its current/phase is 1.4A (RMS); When the 42HS03 used in series mode, its current/phase is 0.7A (RMS); When the 42HS03 used in half-coil or unipolar mode, its current/phase is 1.0A (RMS)".
2. Legend "42HS03, Parallel, HA335, 35VDC, 2.0A (Peak), Half Step" means "This speed-torque curve of the 42HS03 (connected in parallel mode) was done with the HA335 driver. The settings of the HA335 are 2.0A (Peak), Half Step and use 35VDC power supply".
3. The actual characteristics will vary depending on the driver used. Please use these curves only for reference purposes when selecting a motor. You must also conduct a thorough evaluation with the actual driver to be used. Please consult "Leadshine Motor and Driver Packages" for more information about this issue.