

# STANCOR TRANSFORMERS

in the

## WILLIAMSON HIGH FIDELITY AMPLIFIER

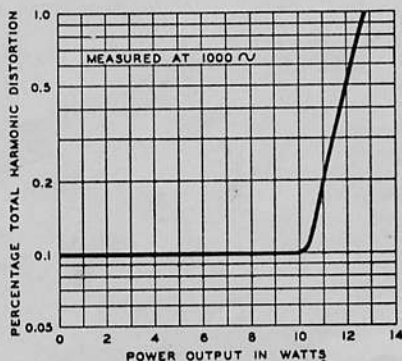
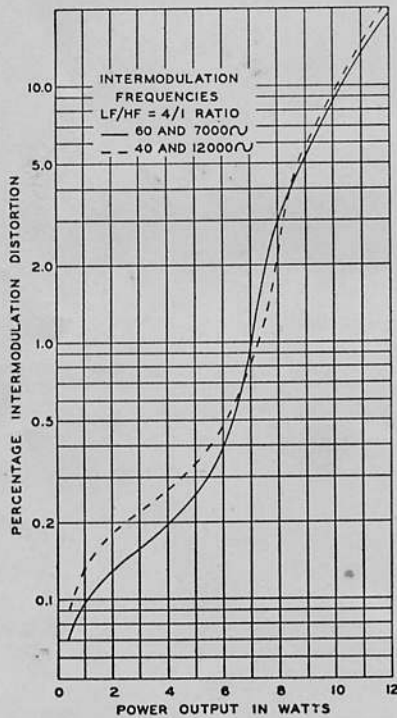
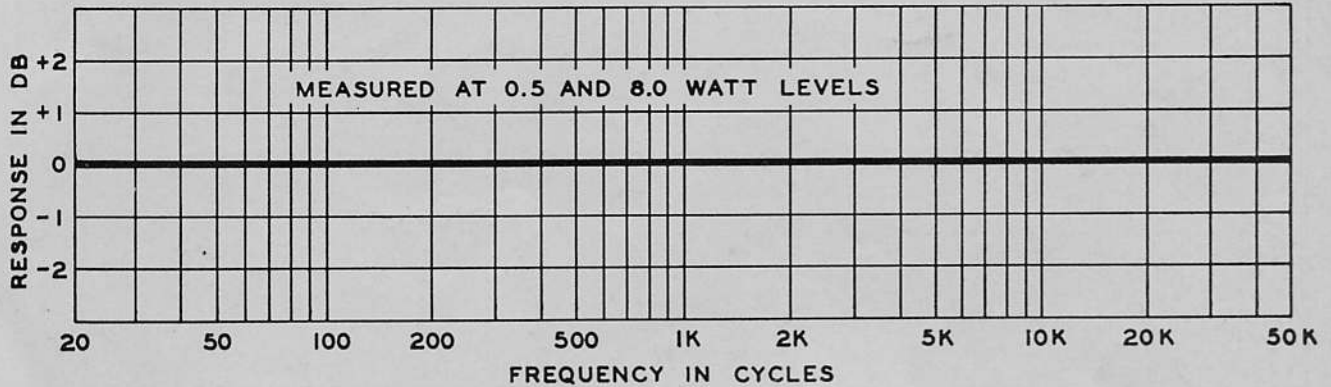

The Stancor-Williamson amplifier has become the audiophiles favorite. Over 5,000 of them have been built in a little over one year. Easy to build and easy on your pocketbook, this true high fidelity amplifier will get the most out of your high fidelity system.

Three Stancor transformers are used in the famous Williamson Circuit to provide you with superb reproduction at low cost. These are Stancor high fidelity output transformer A-8054 (\$10.86), power transformer PC8412 (\$7.95) and filter choke C-1411 (\$3.90) have a total net price of only \$22.71.

Note that the excellent frequency response curve recorded at the 8 watt level remains unchanged at the low level of 0.5 watts, a factor frequently overlooked in amplifier evaluation.

Intermodulation distortion measures only 3% at 8 watts output. Total harmonic distortion, at 1000 cycles, is extremely low and may be considered non-existent below the 10 watt power level.

*A set of two completely punched and finished chassis for this amplifier is available from your distributor. Ask for Stancor Chassis Set WM-8, \$5.75 net.*

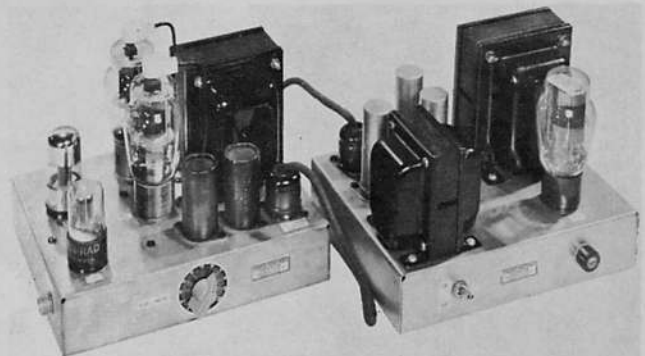

**DISTRIBUTED BY**

### CHICAGO STANDARD TRANSFORMER CORPORATION

Addison and Elston • Chicago 18, Illinois

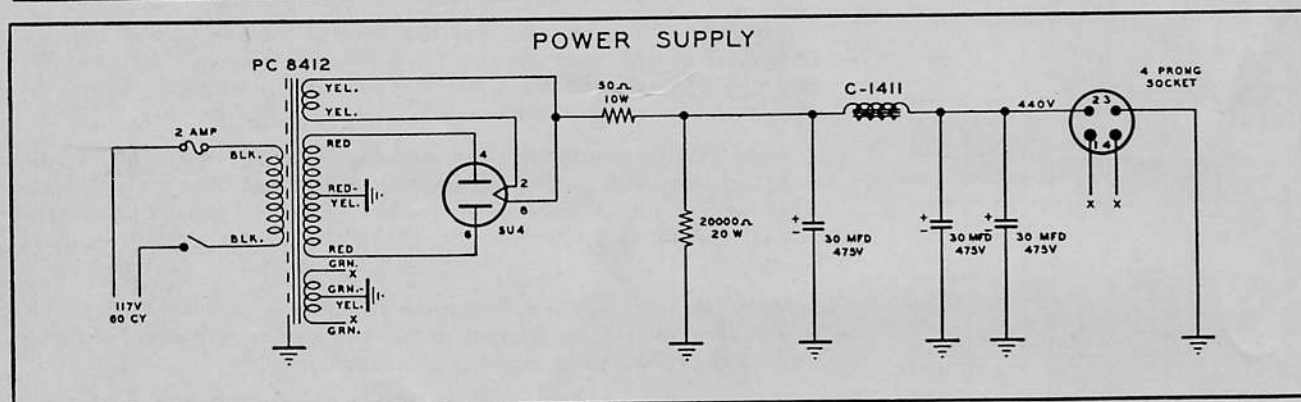
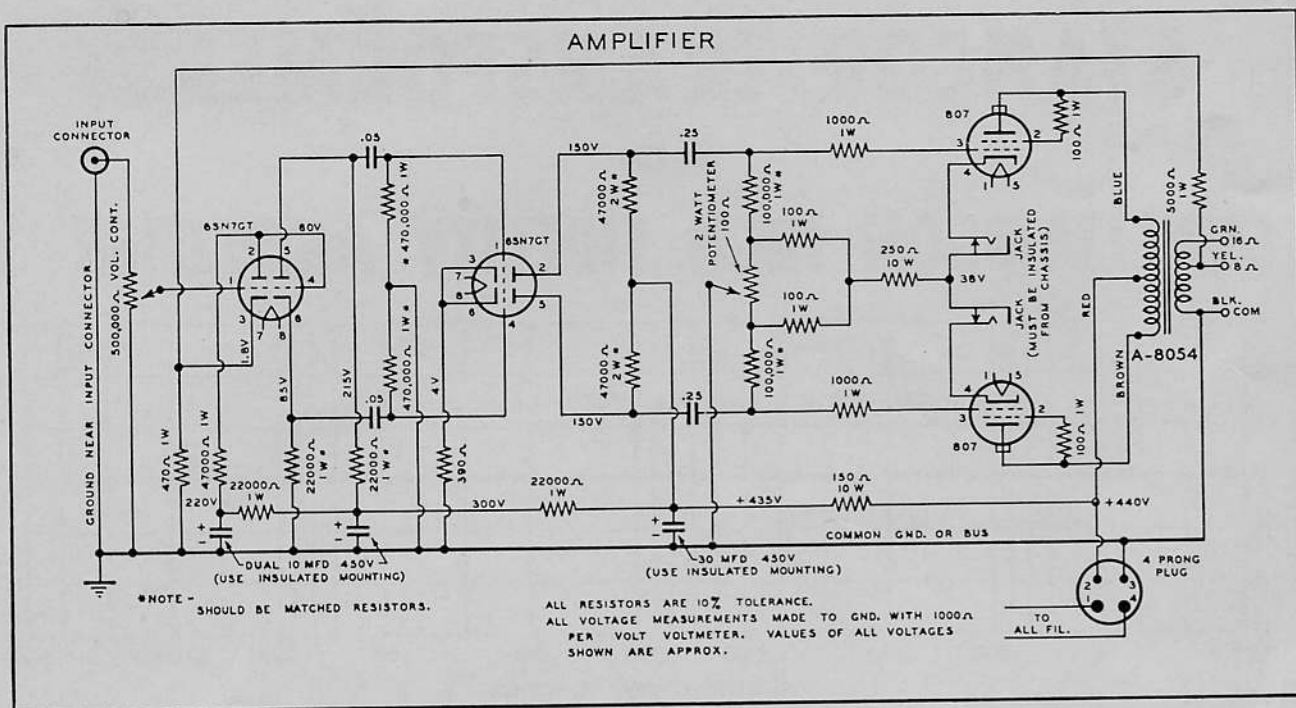

**WARNING:** THE POWER SUPPLY MUST NOT BE OPERATED WITHOUT THE FULL AMPLIFIER LOAD

## PARTS LIST

### AMPLIFIER

- 1 OUTPUT TRANSFORMER, STANCOR #A-8054
- 1 STANCOR AMPLIFIER CHASSIS, WM-8, 9" x 7" x 2"
- 2 6SN7GT tubes
- 2 807 tubes
- 2 470,000 ohm 1 watt 10% resistor
- 2 100,000 ohm 1 watt 10% resistor
- 1 47,000 ohm 1 watt 10% resistor
- 2 47,000 ohm 2 watt 10% resistor
- 4 22,000 ohm 1 watt 10% resistor
- 1 5,000 ohm 1 watt 10% resistor
- 2 1,000 ohm 1 watt 10% resistor
- 1 470 ohm 1 watt 10% resistor
- 1 390 ohm 1 watt 10% resistor
- 4 100 ohm 1 watt 10% resistor
- 1 150 ohm 10 watt wire wound resistor
- 1 250 ohm 10 watt wire wound resistor
- 1 500,000 ohm potentiometer volume control, audio taper
- 1 100 ohm 2 watt potentiometer
- 1 30 Mfd. 475 W.V. electrolytic capacitor, Sprague #TVL-1810 or equiv. (insulated from chassis)
- 1 Dual 10 Mfd. 450 W.V. electrolytic capacitor, Sprague #TVL-2750 or equiv. (insulated from chassis)
- 2 .25 Mfd. 600 W.V. tubular capacitor, Aerovox Type #82 Aerolite or equiv.
- 2 .05 Mfd. 600 W.V. tubular capacitor
- 1 Input connector, Amphenol #75-PC1M
- 1 Power plug, 4 prong, Amphenol #86-CP4
- 2 Octal tube sockets, Amphenol #78-S8
- 2 5 prong tube sockets, Amphenol #78-S5

- 2 Closed circuit jacks, Mallory #A-2 or equiv. (insulate from chassis with Mallory 203 & 212 fiber washers)
- 2 Plate caps, Millen #36002
- 1 Output terminal strip, four terminals (one terminal not used)
- 9 Terminal tie lug strips, two lug type
- 2 Rubber Grommets to fit 3/8" diameter hole

### POWER SUPPLY

- 1 POWER TRANSFORMER, STANCOR #PC8412
- 1 FILTER CHOKE STANCOR #C-1411
- 1 STANCOR POWER SUPPLY CHASSIS, WM-8, 9" x 7" x 2"
- 1 5U4 tube
- 3 30 Mfd. 475 W.V. electrolytic capacitor, Sprague #TVL-1810 or equiv.
- 1 20,000 ohm 20 watt wire wound resistor
- 1 50 ohm 10 watt wire wound resistor
- 1 8 prong socket, Amphenol #78-S8
- 1 4 prong socket, Amphenol #77-MIP-4
- 1 Single pole single throw toggle switch
- 1 Fuse extractor post, Littelfuse #341001
- 1 2 amp fuse, type 3AG
- 1 Line cord and plug
- 1 Terminal tie lug strip, 2 lug type

### POWER CABLE

- 1 Female connector, Amphenol #78-PF4
- 1 Male connector, Amphenol #86-PM4
- 1 4-wire cable, length as required

# WILLIAMSON HIGH FIDELITY AMPLIFIER

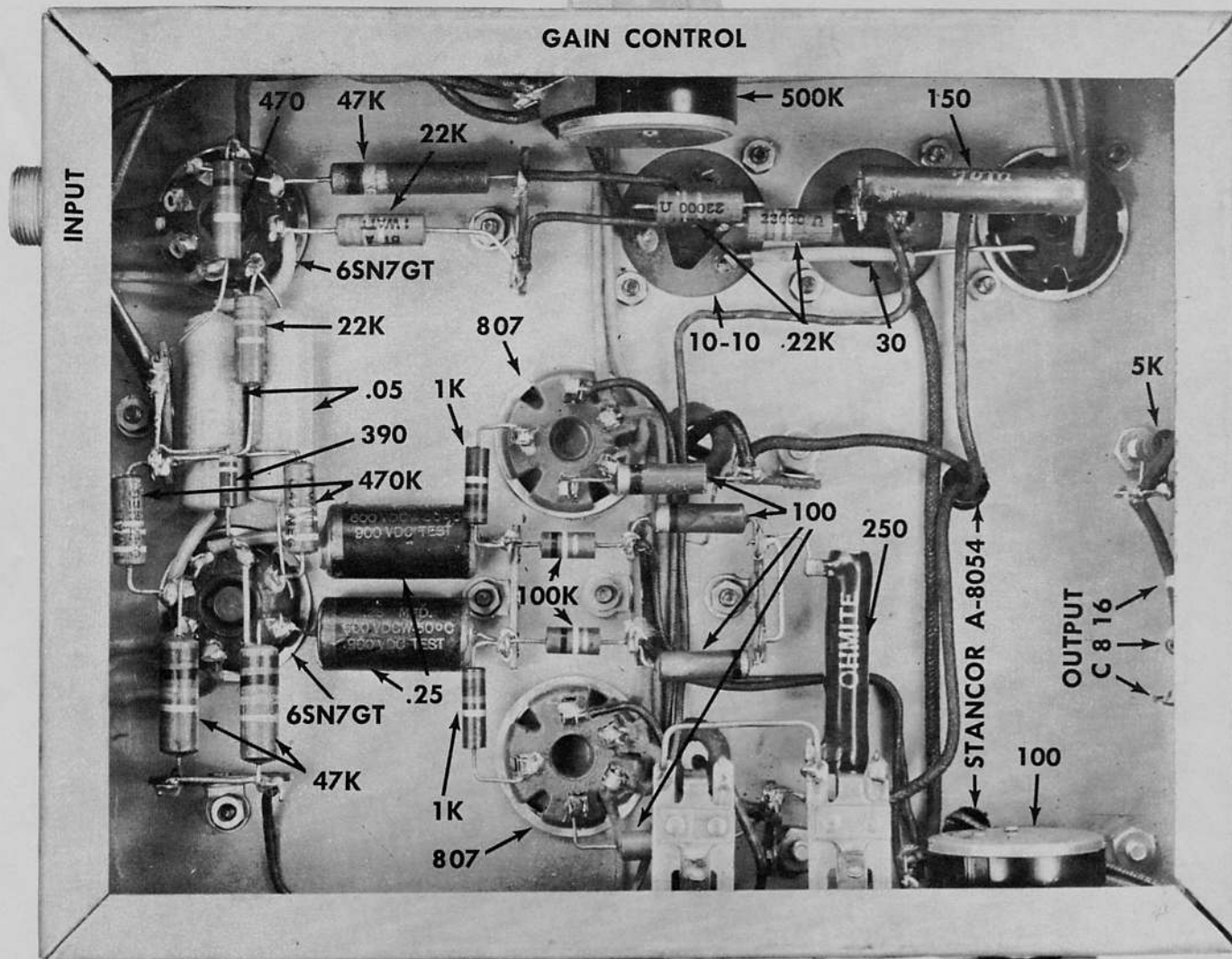

USE 0-100 MILLIAMETER  
EQUALIZE 807 CATHODE CURRENT →

## AMPLIFIER UNIT

### Pre-amplifier and Tone Control Suggestions.

The basic amplifier circuit should not be revised to include tone controls or additional stages. Preamplification and tone compensation must be accomplished prior to the input stage.

There are a number of commercially available circuits which incorporate these features and will accommodate several types of input. Your Stancor distributor will be able to recommend the proper one for you. A unit containing its own power supply is preferable, since it simplifies installation.

For those who prefer to construct their own equipment, see PHOTOFAC INDEX No. 33, July-August 1952 for information on the construction of a preamplifier and tone-control unit. This article has been reprinted as Stancor Bulletin 456 and is available from your distributor.

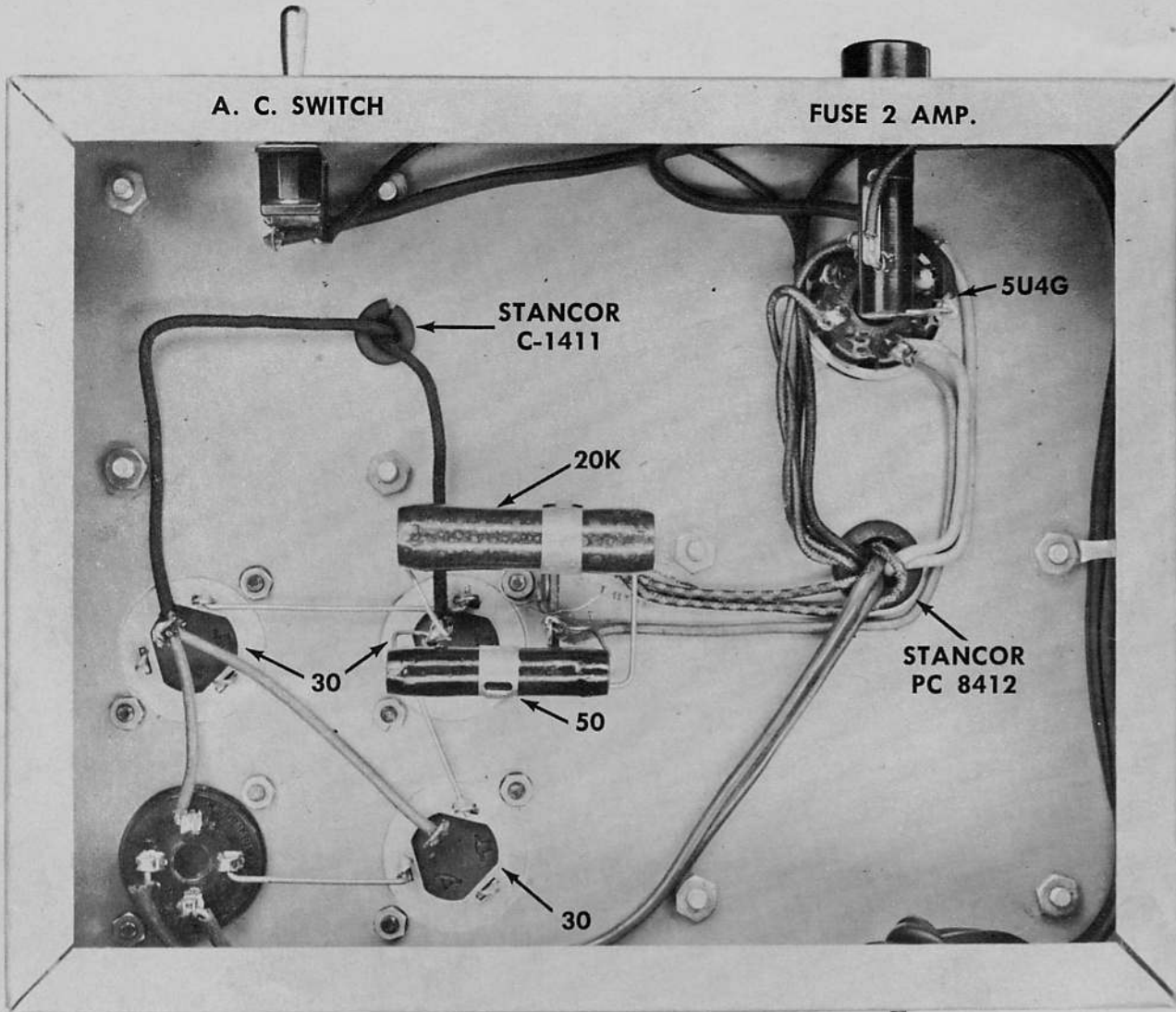

**POWER SUPPLY UNIT**

**CHICAGO STANDARD TRANSFORMER CORPORATION**

Addison and Elston • Chicago 18, Illinois

# STANCOR ULTRA-LINEAR WILLIAMSON HIGH FIDELITY AMPLIFIER

USING STANCOR ULTRA-LINEAR TRANSFORMER A-8072

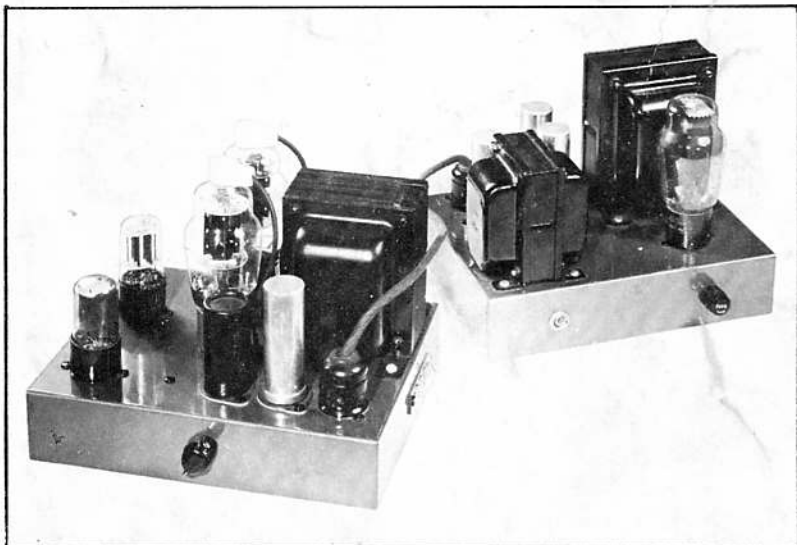

Now you can build an ultra-linear version of the famous Stancor-Williamson Amplifier, using the newly developed Stancor ultra-linear output transformer A-8072.

This improved transformer and circuit provides much more distortionless power than the original Williamson circuit. Intermodulation distortion is 3% at 27 watts equivalent sine wave power. Total harmonic distortion, measured at 1000 cycles, is less than 1% at 25 watts and less than 0.1% at 22 watts.

Frequency response of the amplifier is absolutely flat to 40,000 cycles, measured at 1 watt, 10 watts, and 20 watt levels. At the average listening level of 1 watt, frequency response is plus or minus 1db at 100,000 cycles, assuring you of true high-fidelity reproduction over the entire audible range.

Over 7,000 regular Stancor-Williamson Amplifiers have already been built. If you now have one of these fine amplifiers, you can convert it to ultra-linear operation. A few simple circuit changes and the installation of A-8072 (as described on the next page) are all that is necessary.

Stancor supplies a set of two completely punched and finished chassis for the ultra-linear amplifier, Chassis Set WM-8, \$5.75 net. In addition to Stancor Ultra Linear Output Transformer A-8072, \$15.00 net, this amplifier uses power transformer PC8412, \$8.58 net, and filter choke C-1411, \$4.29 net. The other electronic components used cost about \$25.00. They are all stock parts, and can be readily obtained from your Stancor distributor.

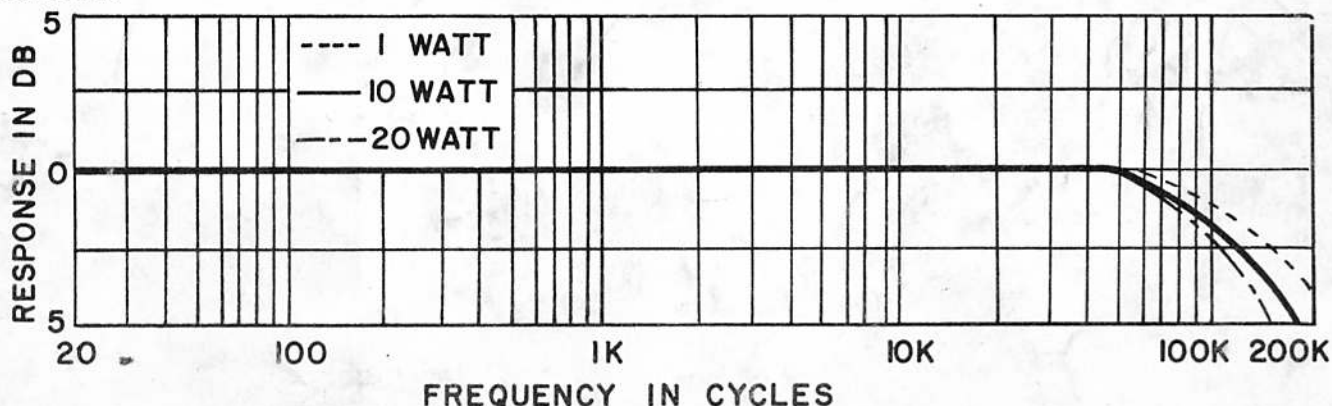
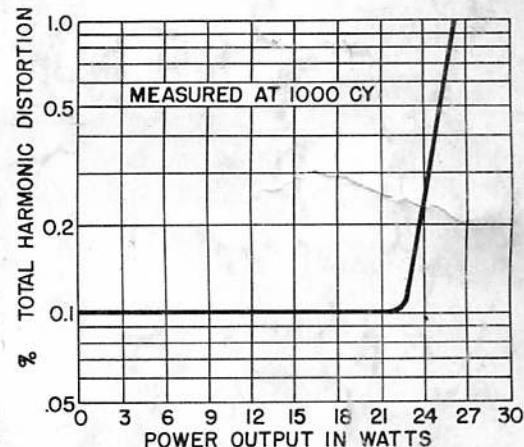
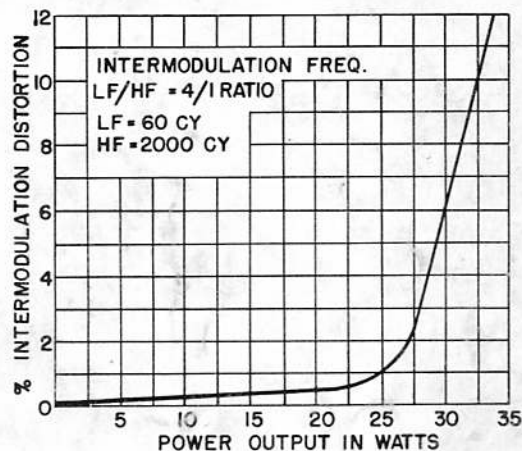

## AMPLIFIER

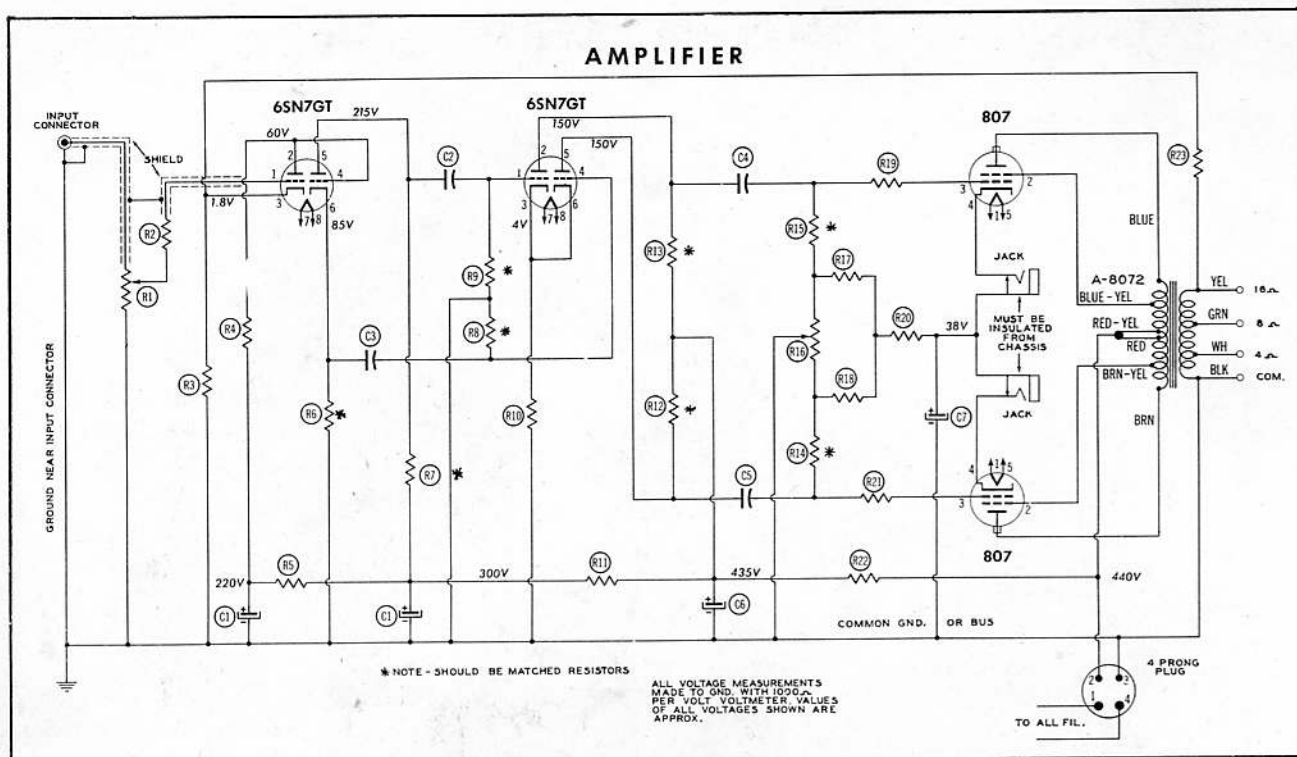

## AMPLIFIER PARTS LIST

- |  |   |
|--|---|
| <p>1 STANCOR OUTPUT TRANSFORMER #A-8072<br/>                     1 STANCOR AMPLIFIER CHASSIS, WM-8,<br/>                     9" x 7" x 2"<br/>                     2 6SN7GT tubes<br/>                     2 807 tubes<br/>                     R1 500,000 ohm volume control, Audio Taper<br/>                     R2 10,000 ohm 1/2 watt resistor<br/>                     R3 470 ohm 1 watt resistor<br/>                     R4 47,000 ohm 1 watt resistor<br/>                     R5 22,000 ohm 1 watt resistor<br/>                     R6*, R7* 22,000 ohm 1 watt resistor<br/>                     R8*, R9* 470,000 ohm 1 watt resistor<br/>                     R10 390 ohm 1 watt resistor<br/>                     R11 22,000 ohm 1 watt resistor<br/>                     R12*, R13* 47,000 ohm 2 watt resistor<br/>                     R14*, R15* 100,000 ohm 1 watt resistor<br/>                     R16 100 ohm 2 watt potentiometer<br/>                     R17, R18, 100 ohm 1 watt resistor<br/>                     R19 1000 ohm 1 watt resistor<br/>                     R20 250 ohm 10 watt wire wound resistor</p> | <p>R21 1000 ohm 1 watt resistor<br/>                     R22 150 ohm 10 watt wire wound resistor<br/>                     R23 10,000 ohm 1 watt resistor<br/>                     C1 Dual 10 Mfd. 450 W. V. electrolytic capacitor<br/>                     (insulated from chassis)<br/>                     C2, C3, C4, C5 .25 Mfd. 600 W. V. tubular capacitor<br/>                     C6 30 Mfd. 475 W. V. electrolytic capacitor<br/>                     (insulated from chassis)<br/>                     C7 250 Mfd. 50 W. V. electrolytic capacitor<br/>                     1 Input connector, Amphenol #75-PC1M<br/>                     1 Power plug, 4 prong, Amphenol #86-CP4<br/>                     2 5 Prong tube sockets, Amphenol #78-S5<br/>                     2 Octal tube sockets, Amphenol #78-S8<br/>                     2 Closed circuit jacks, Mallory #A-2 or equiv. (insulate from chassis with Mallory 203 &amp; 212 fiber washers)<br/>                     2 Plate Caps, Müllen #36002<br/>                     1 Output terminal strip, three terminals<br/>                     9 Terminal tie lug strips, two lug type<br/>                     2 Rubber Grommets to fit 3/8" diameter hole.</p> |
|--|---|

*All resistors 10% or better. \*Note—Should be matched resistors.*

### Data for converting regular Stancor-Williamson Amplifier to Ultra-Linear operation\*

1. Remove the two 100 ohm resistors from the two 807 tube's plates and screen grids.
2. Add resistor R2 and capacitor C7.
3. Change input lead (from input connector to grid of first 6SN7GT) from regular to *shielded* wire.
4. Change capacitors C2 and C3 from .05 mfd. to 0.25 mfd.
5. Change resistor R23 from 5000 ohm, 1 watt to 10,000 ohm, 1 watt.
6. Remove A-8054 output transformer and connect A-8072 Ultra-Linear transformer as shown on schematic.

*\*All resistor and capacitor designations refer to new schematic. Copies of the original Stancor-Williamson circuit, for comparison, can be obtained from Stancor Bulletin 382R.*

# AMPLIFIER UNIT

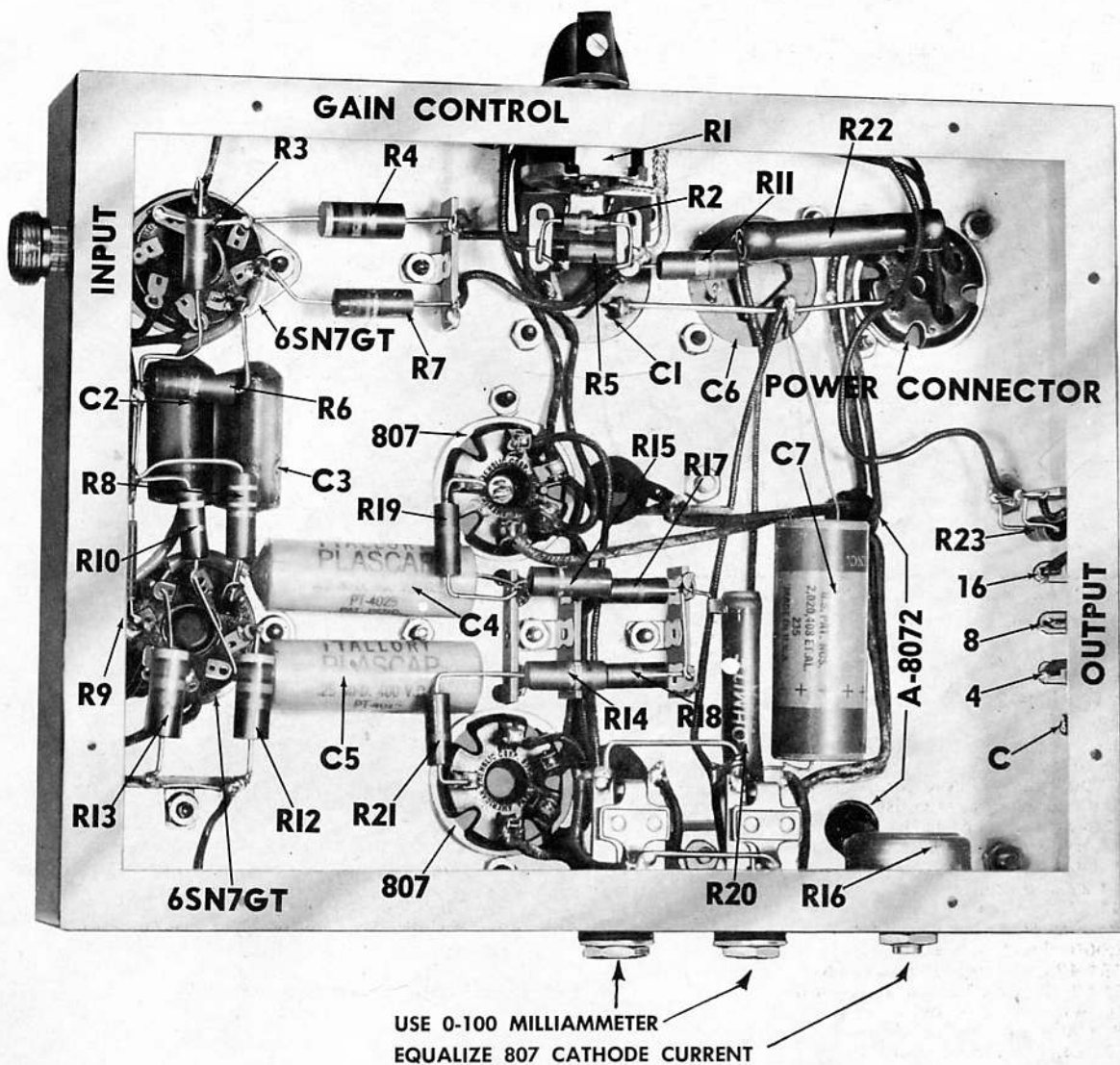

## Pre-amplifier and Tone Control Suggestions

The basic amplifier circuit should not be revised to include tone controls or additional stages. Pre-amplification and tone compensation must be accomplished prior to the input stage.

There are a number of commercially available circuits which incorporate these features and will accommodate several types of input. Your Stancor distributor will be able to recommend the proper one for you.

A unit containing its own power supply is preferable, since it simplifies installation.

For those who prefer to construct their own equipment, see PHOTOFACT INDEX No. 33, July-August 1952 for information on the construction of a pre-amplifier and tone-control unit.

This article has been reprinted as Stancor Bulletin 456R and is available from your distributor.

# POWER SUPPLY UNIT

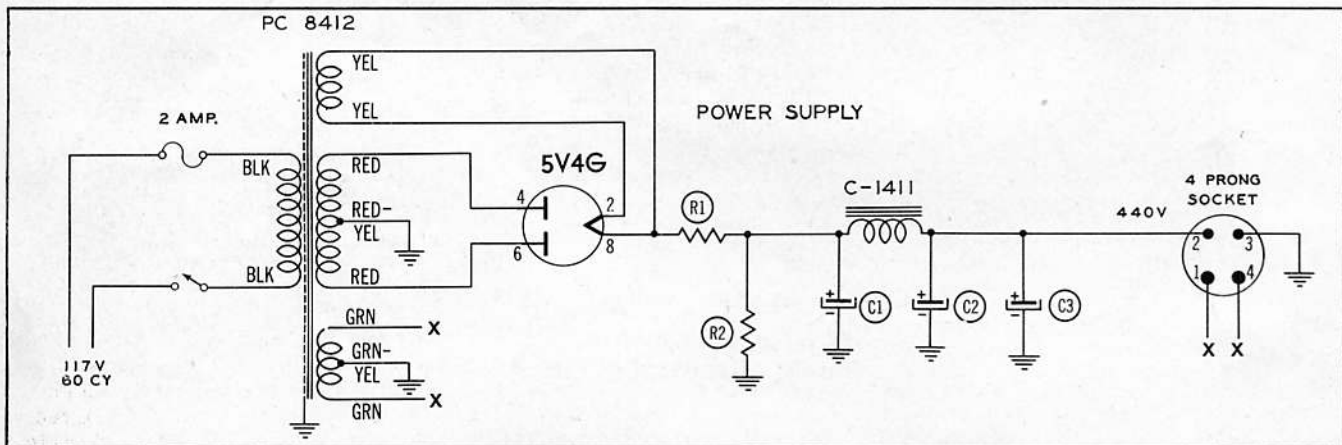
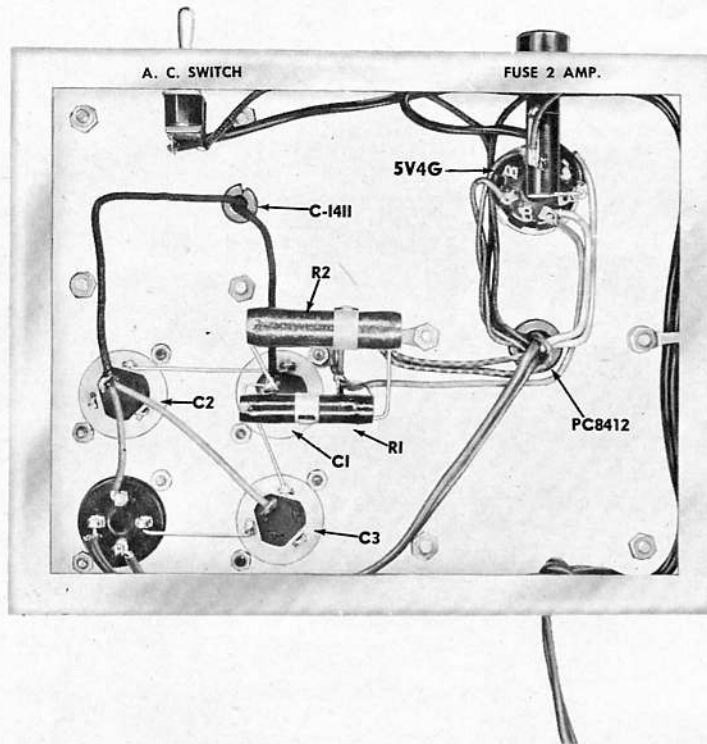

**WARNING:** THE POWER SUPPLY MUST NOT BE OPERATED WITHOUT THE FULL AMPLIFIER LOAD

## PARTS LIST

### POWER SUPPLY

- 1 STANCOR POWER TRANSFORMER #PC-8412
- 1 STANCOR FILTER CHOKE #C-1411
- 1 STANCOR POWER SUPPLY CHASSIS, WM-8, 9" x 7" x 2"
- 1 5V4G Tube
- C1, C2, C3 30 Mfd. 475 W. V. electrolytic capacitor.
- R2 20,000 ohm 20 watt wire wound resistor
- R1 50 ohm 10 watt wire wound resistor
- 1 8 prong socket, Amphenol #78-S8
- 1 4 prong socket, Amphenol #77-MIP-4

- 1 Single pole single throw toggle switch
- 1 Fuse extractor post, Littelfuse #341001
- 1 2 amp. fuse, type 3AG
- 1 Line cord and plug
- 1 Terminal tie lug strip, 2 lug type

### POWER CABLE

- 1 Female connector, Amphenol #78-PF4
- 1 Male connector, Amphenol #86-PM4
- 1 4-wire cable, length as required.

*All resistors 10% or better.*

# CHICAGO STANDARD TRANSFORMER CORPORATION

ADDISON AND ELSTON • CHICAGO 18, ILLINOIS