

Part 4

***Parts
Catalog***

Canon

SPEEDLITE 380EX

C50-0721

**PARTS
CATALOG**

CANON SPEEDLITE 380 EX

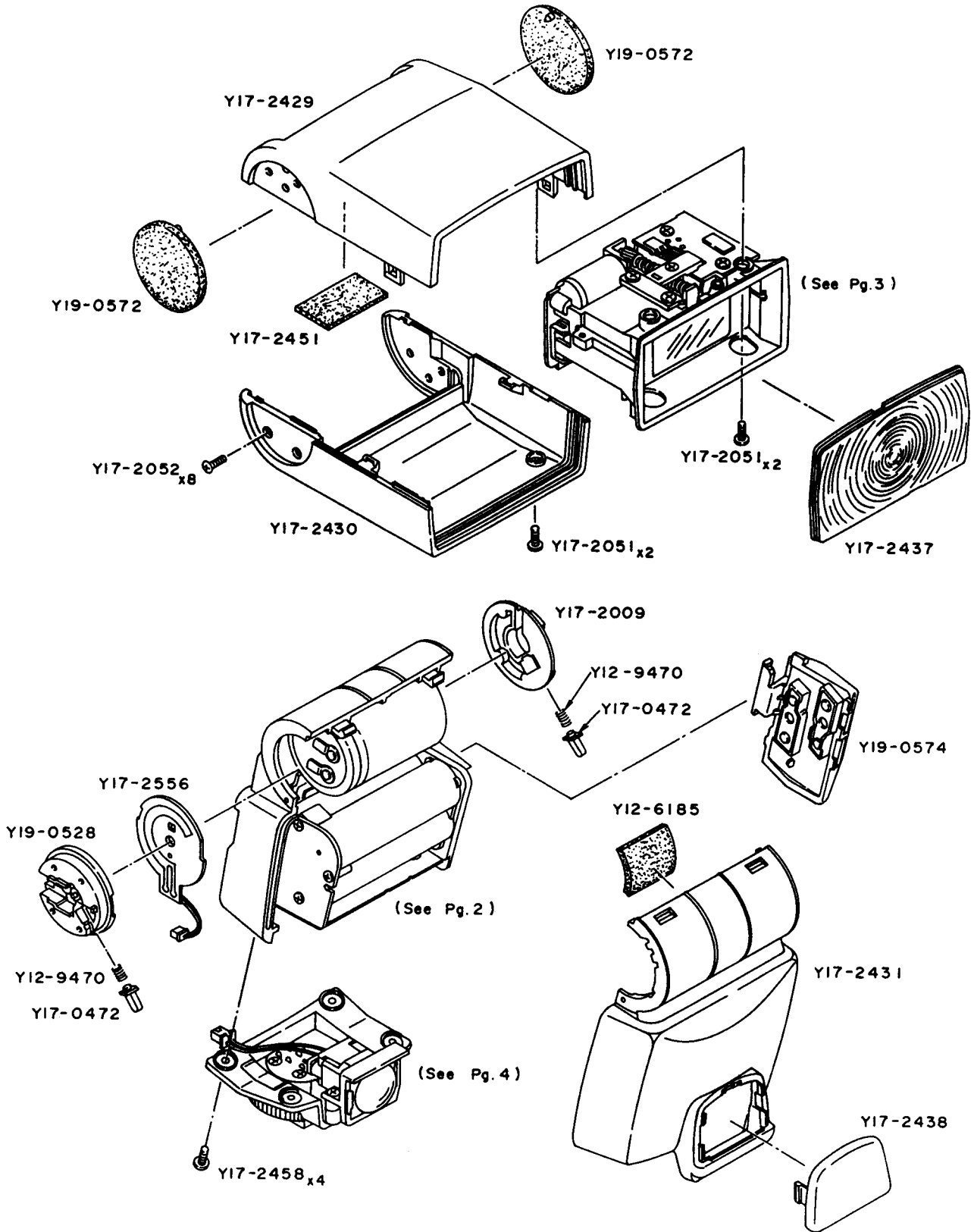

PARTS LIST

REF.NO. C50-0721

NEW	PARTS NO.	CLASS	QTY	DESCRIPTION	
*	Y12-6185-000	E	1	SPACER	スペーサー
	Y12-9470-000	E	2	SPRING, COIL	圧縮スプリング
	Y17-0472-000	E	2	PIN, CLICK	クリックピン
	Y17-2009-000	E	2	WHEEL, PIVOT(R)	バウンス軸 (右)
	Y17-2051-000		4	SCREW	
	Y17-2052-000		8	SCREW	
*	Y17-2429-000	D	1	COVER, TOP	上カバー
*	Y17-2430-000	D	1	COVER, BOTTOM	下カバー
*	Y17-2431-000	D	1	COVER, FRONT	前カバー
*	Y17-2437-000	D	1	PANEL, FRESNEL	フレネルレンズ
*	Y17-2438-000	D	1	PANEL, AF LED	AF LED パネル
*	Y17-2451-000	E	1	SPACER	スペーサー
*	Y17-2458-000		4	SCREW	
*	Y17-2556-000	E	1	PCB(F)	F基板
	Y19-0528-000	D	1	WHEEL, PIVOT(L)	バウンス軸 (左)
*	Y19-0572-000	D	2	COVER, RUBBER	ゴムカバー
*	Y19-0574-000	D	1	COVER ASS'Y, BATTERY	電池蓋ユニット

CANON SPEEDLITE 380EX

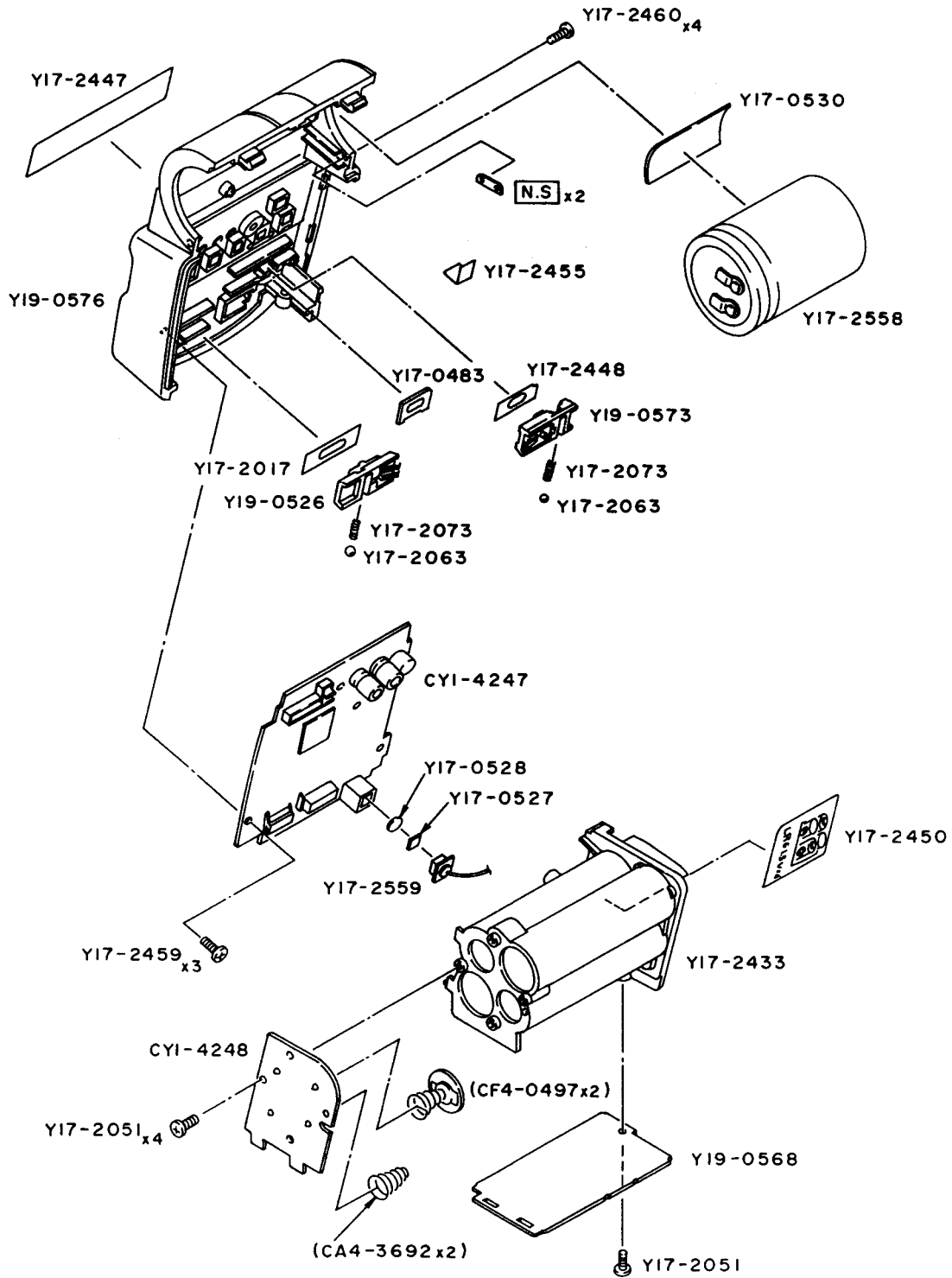

PARTS LIST

REF.NO. C50-0721

NEW	PARTS NO.	CLASS	QTY	DESCRIPTION	
	CA4-3692-000	D	2	CONTACT, BATTERY	電池接点 (-)
	CF4-0497-000	C	2	CONTACT ASS'Y, BATTERY	電池接点 (+)
*	CY1-4247-000	D	1	PCB ASS'Y(A)	A基板
*	CY1-4248-000	D	1	PCB ASS'Y(C)	C基板
	Y17-0483-000	D	1	BUTTON, TEST	テスト発光ボタン
	Y17-0527-000	D	1	FILTER	視感度補正フィルター
	Y17-0528-000	D	1	FILTER, ND	NDフィルター
*	Y17-0530-000	E	1	TAPE, DOUBLE-SIDED	両面テープ
	Y17-2017-000	D	1	PLATE, MAIN SWITCH	スイッチ銘板
	Y17-2051-000		5	SCREW	
	Y17-2063-000	D	2	BALL	クリックボール
*	Y17-2073-000	E	2	SPRING, COIL	圧縮スプリング
*	Y17-2433-000	E	1	CASE, BATTERY	電池ケース
*	Y17-2447-000	D	1	PLATE, REAR	後銘板
*	Y17-2448-000	E	1	PLATE, CONTROL SWITCH	スイッチ銘板
*	Y17-2450-000	E	1	STICKER, BATTERY	電池シール
*	Y17-2455-000	E	1	INSULATOR	絶縁シート
*	Y17-2459-000		3	SCREW	
*	Y17-2460-000		4	SCREW	
*	Y17-2558-000	D	1	CAPACITOR, AL-EL MAIN	メインコンデンサー
*	Y17-2559-000	D	1	CONNECTOR, OPTICAL	ファイバーワイヤー
	Y19-0526-000	D	1	SWITCH ASS'Y, MAIN	メインスイッチ
*	Y19-0568-000	D	1	PCB ASS'Y(B)	B基板
*	Y19-0573-000	D	1	SWITCH ASS'Y, CONTROL	調整スイッチ
*	Y19-0576-000	D	1	COVER ASS'Y, REAR	後カバーユニット

CANON SPEEDLITE 380EX

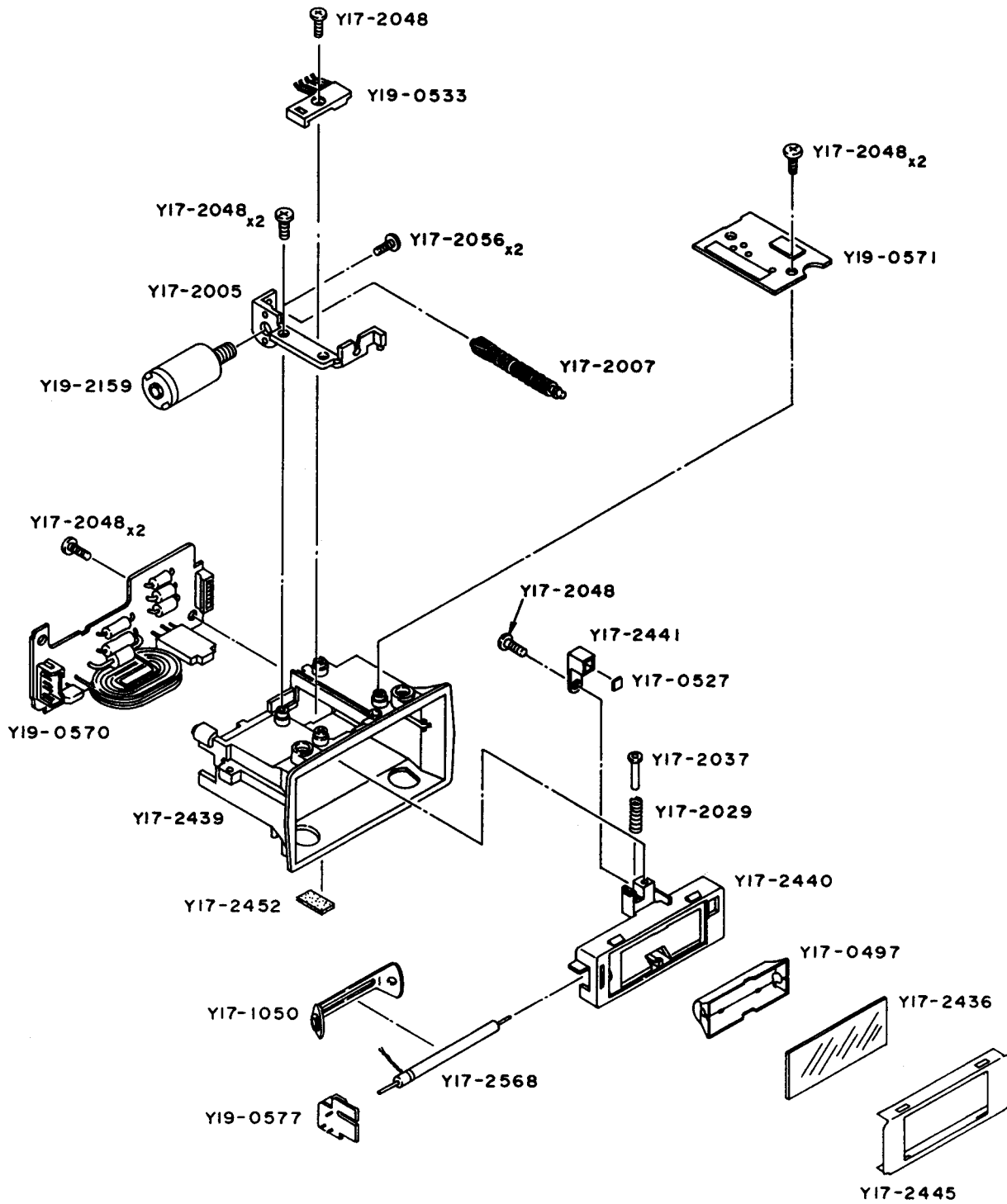

PARTS LIST

REF.NO. C50-0721

NEW	PARTS NO.	CLASS	QTY	DESCRIPTION	
	Y17-0497-000	E	1	REFLECTOR, MAIN	反射傘
	Y17-0527-000	D	1	FILTER	視感度補正フィルター
	Y17-1050-000	E	1	BUSH, MOUNTING	Xeブッシング
	Y17-2005-000	E	1	HOLDER, ZOOM MOTOR	モーター固定台
*	Y17-2007-000	E	1	SHAFT, ZOOM	ズーム軸
	Y17-2029-000	E	1	SPRING, COIL	クラッチスプリング
	Y17-2037-000	E	1	PIN, ZOOM	ズームピン
	Y17-2048-000		8	SCREW	
	Y17-2056-000		2	SCREW	
	Y17-2159-000	D	1	MOTOR, ZOOM	ズームモーター
*	Y17-2436-000	D	1	PANEL, FRONT	前パネル
*	Y17-2439-000	E	1	HOUSING, XENON LAMP	フード
*	Y17-2440-000	D	1	FRAME, MAIN LAMP	反射傘カバー
*	Y17-2441-000	E	1	CASE, SENSOR	センサーケース
*	Y17-2445-000	E	1	HOLDER, PANEL	パネル保持板
*	Y17-2452-000	E	1	CUSHION	クッション
*	Y17-2568-000	D	1	LAMP, XENON	キセノンランプ
	Y19-0533-000	D	1	SWITCH ASS'Y, ZOOM	ズームスイッチ
*	Y19-0570-000	D	1	PCB ASS'Y (D)	D基板
*	Y19-0571-000	D	1	PCB ASS'Y(E)	E基板
*	Y19-0577-000	D	1	PCB ASS'Y(G)	G基板

CANON SPEEDLITE 380EX

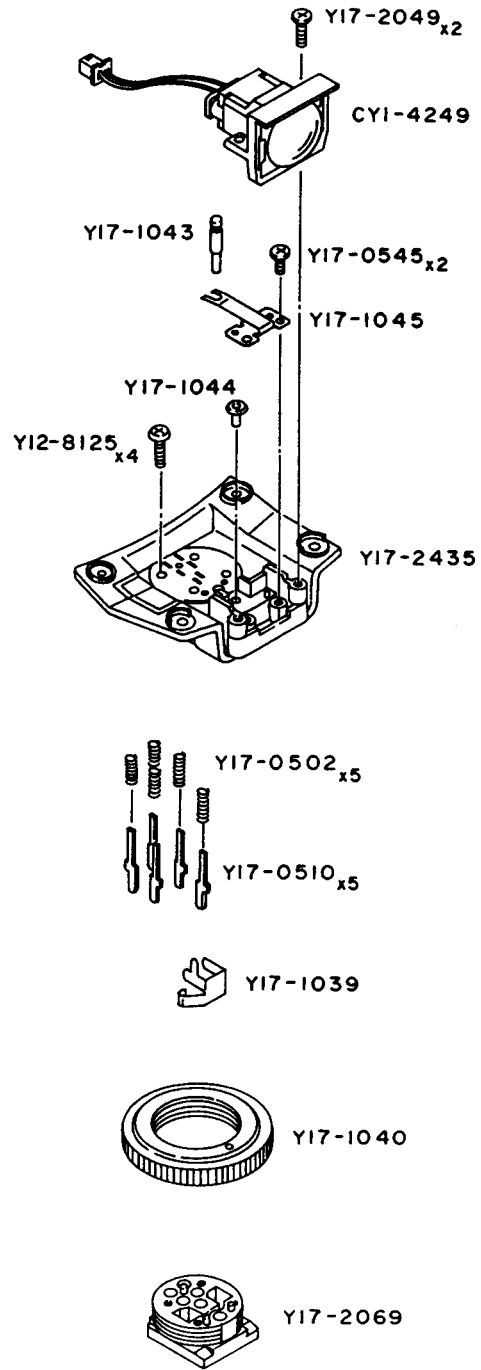
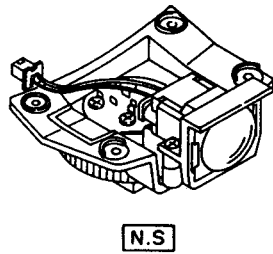

PARTS LIST

REF.NO. C50-0721

NEW	PARTS NO.	CLASS	QTY	DESCRIPTION	
*	CY1-4249-000	D	1	LED UNIT, AF	AF LED ユニット
	Y12-8125-000		4	SCREW	
	Y17-0502-000	D	5	SPRING, COIL	シュー接点スプリング
	Y17-0510-000	D	5	CONTACT, SHOE	シュー接点
	Y17-0545-000		2	SCREW	
	Y17-1039-000	D	1	CONTACT, SHOE (-)	シュー (-) 接片
	Y17-1040-000	D	1	NUT, SHOE	シューナット
	Y17-1043-000	D	1	PIN, SHOE LOCK	シューロックピン
	Y17-1044-000	D	1	PIN, LOCK	ロック解除ピン
	Y17-1045-000	D	1	CONTACT, SHOE LOCK	シューロックスプリング
	Y17-2049-000		2	SCREW	
	Y17-2069-000	C	1	SHOE	シューモールド
*	Y17-2435-000	D	1	CASE, SHOE	シューケース

ELECTRIC PARTS LIST

REF.NO. C50-0721

NEW	PARTS NO.	CLASS	QTY	DESCRIPTION	
*	Y17-2560-000		1	LEAD ASSY CN-1	リード線セット
*	Y17-2561-000		1	LEAD ASSY CN-2	リード線セット
*	Y17-2562-000		1	LEAD ASSY CN-3	リード線セット
*	Y17-2563-000		1	LEAD ASSY CN-4	リード線セット
*	Y17-2564-000		1	LEAD ASSY CN-5	リード線セット
*	Y17-2565-000		1	LEAD ASSY CN-6	リード線セット
*	Y17-2566-000		1	LEAD ASSY CN-7	リード線セット
*	Y17-2567-000		1	LEAD ASSY CN-8	リード線セット

PARTS LIST INDEX

REF.NO. C50-0721

NEW	PARTS NO.	PAGE	NEW	PARTS NO.	PAGE
	CA4-3692-000	2	*	Y17-2431-000	1
	CF4-0497-000	2	*	Y17-2433-000	2
*	CY1-4247-000	2	*	Y17-2435-000	4
*	CY1-4248-000	2	*	Y17-2436-000	3
*	CY1-4249-000	4	*	Y17-2437-000	1
*	Y12-6185-000	1	*	Y17-2438-000	1
	Y12-8125-000	4	*	Y17-2439-000	3
	Y12-9470-000	1	*	Y17-2440-000	3
	Y17-0472-000	1	*	Y17-2441-000	3
	Y17-0483-000	2	*	Y17-2445-000	3
	Y17-0497-000	3	*	Y17-2447-000	2
	Y17-0502-000	4	*	Y17-2448-000	2
	Y17-0510-000	4	*	Y17-2450-000	2
	Y17-0527-000	2,3	*	Y17-2451-000	1
	Y17-0528-000	2	*	Y17-2452-000	3
*	Y17-0530-000	2	*	Y17-2455-000	2
	Y17-0545-000	4	*	Y17-2458-000	1
	Y17-1039-000	4	*	Y17-2459-000	2
	Y17-1040-000	4	*	Y17-2460-000	2
	Y17-1043-000	4	*	Y17-2556-000	1
	Y17-1044-000	4	*	Y17-2558-000	2
	Y17-1045-000	4	*	Y17-2559-000	2
	Y17-1050-000	3	*	Y17-2560-000	5
	Y17-2005-000	3	*	Y17-2561-000	5
*	Y17-2007-000	3	*	Y17-2562-000	5
	Y17-2009-000	1	*	Y17-2563-000	5
	Y17-2017-000	2	*	Y17-2564-000	5
	Y17-2029-000	3	*	Y17-2565-000	5
	Y17-2037-000	3	*	Y17-2566-000	5
	Y17-2048-000	3	*	Y17-2567-000	5
	Y17-2049-000	4	*	Y17-2568-000	3
	Y17-2051-000	1,2		Y19-0526-000	2
	Y17-2052-000	1		Y19-0528-000	1
	Y17-2056-000	3		Y19-0533-000	3
	Y17-2063-000	2	*	Y19-0568-000	2
	Y17-2069-000	4	*	Y19-0570-000	3
*	Y17-2073-000	2	*	Y19-0571-000	3
	Y17-2159-000	3	*	Y19-0572-000	1
*	Y17-2429-000	1	*	Y19-0573-000	2
*	Y17-2430-000	1	*	Y19-0574-000	1

PARTS LIST INDEX

REF.NO. C50-0721

NEW	PARTS NO.	PAGE	NEW	PARTS NO.	PAGE
*	Y19-0576-000	2			
*	Y19-0577-000	3			