

BEKO **COLOUR TELEVISIONS**

Service Manual
E1 CHASSIS

CONTENTS	PAGE
○ <u>Safety Instructions</u>	<u>2</u>
○ <u>Technical Specifications</u>	<u>3</u>
○ <u>Remote Control</u>	<u>4</u>
○ <u>Preperations</u>	<u>5</u>
○ <u>Operating Your TV</u>	<u>6</u>
○ <u>Block Diagram</u>	<u>10</u>
○ <u>IC Specs</u>	<u>11</u>
○ <u>Pin Voltages of IC's</u>	<u>18</u>
○ <u>OSCILLOGRAPHs OF SOME IC PINS</u>	<u>19</u>
○ <u>Electrical Adjustments</u>	<u>22</u>
○ <u>Channel Frequency Tables</u>	<u>25</u>
○ <u>Spare Part List</u>	<u>27</u>

1. SAFETY INSTRUCTIONS

GENERAL GUIDELINES

1. It is advised to insert an isolation transformer in the AC supply before servicing a hot chassis.
2. Potentials as high as 33KV are present when this receiver is in operation. Operation of the receiver without the rear cover involves the danger of a shock hazard from the receiver power supply. Servicing should not be attempted by any one who is not competent with the precautions necessary when working on the high voltage equipment. Always discharge the anode of the tube.
3. When servicing observe the original lead dress in the high voltage circuits. If a short circuit is found, replace all the parts which have been overheated or damaged by the short circuit.
4. Always use the manufacturer's replacement safety components. The critical safety components marked with  on the schematics diagrams should not be replaced by other substitutes. Other substitute may create the electrical shock, fire or other hazards. Take attention to replace the spacers with the originals. Furthermore where a short circuit has occurred, replace those components that indicate evidence of overheating.
5. After servicing, see that all the protective devices such as insulation barriers, insulation papers, shields and isolation R-C combinations are correctly installed.
6. When the receiver is not being used for a long time of period of time, unplug the power cord from the AC outlet.
7. After servicing make the following leakage current checks to prevent the customer from being exposed to shock hazard.

LEAKAGE CURRENT COLD CHECK

1. Unplug the AC cord and connect a jumper between the two prongs of the plug.
2. Turn the receiver's power switch on.
3. Measure the resistance value with an ohmmeter, between the jumpered AC plug and each exposed metallic cabinet part on

the receiver, such as screw heads, aerials, connectors, control shafts etc. When the exposed metallic part a return path to the chassis the reading should be between 4Mohm and the 20Mohm. When the exposed metal does not have a return path to the chassis, the reading must be infinite.

LEAKAGE CURRENT HOT CHECK

1. Plug the AC cord directly in to the AC outlet. Do not use an isolation transformer for this check.
2. Connect a 2Kohm 10W resistor in series with an exposed metallic part on the receiver and an earth, such as a water pipe.
3. Use an AC voltmeter with high impedance to measure the potential across the resistor.
4. Check each exposed metallic part and check the voltage at the each point.
5. Reverse the AC plug at the outlet and repeat each of the above measurements.
6. The potential at the any point should not exceed 1.4 Vrms. In case a measurement is outside the limits specified, there is the possibility of a shock hazard, and the receiver should be repaired and rechecked before it is returned to the customer.

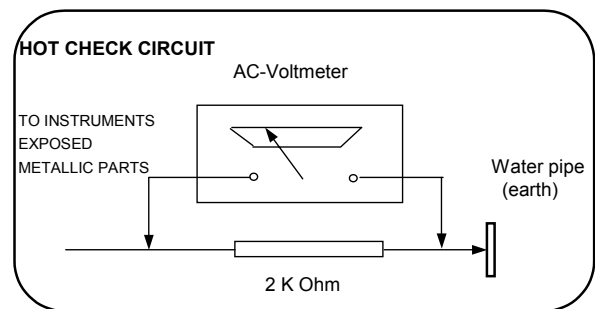

Figure 1

X-RAY RADIATION WARNING

The primary source of X-ray radiation in this receiver is the picture tube. The chassis is specially constructed to limit X-ray radiation. For continued X-ray radiation protection, replace the tube with the same type of the original one.

CAUTION

AFTER REMOVAL OF THE ANODE CAP, DISCHARGE THE ANODE OF THE PICTURE TUBE AND THE ANODE CAP TO THE METAL CHASSIS, CRT SHIELD, OR THE CARBON PAINTED ON THE CRT WITH A HIGH VOLTAGE PROBE

Power source:	220-240V AC, 50-60Hz	
Power consumption (nom.) :	40 W	14"
	50 W	20", 21"
Standby power consumption :	4 W	
Aerial impedance :	75Ohm, coaxial type	
Receiving system ¹:	PAL BG PAL SECAM BG PAL SECAM BG DK PAL I	
Receiving channels:	VHF BAND I	CH2-4
	VHF BAND III	CH5-12
	CABLE TV	S1-41
	UHF BAND	CH21-69
Audio outputs :	2.0W RMS at %10 THD	14"
	2.5W RMS at %10 THD	20", 21"
High Voltage :	23 ± 0.5 KV	14"
	25 ± 0.5 KV	20", 21"
Focus voltage :	%25.6 ± %38 of EHT	
Grid 2 voltage :	0-1400 V	
Heater voltage :	6.2 ± 0.2 Vrms	
Video/Audio Terminals :	AV1 IN	Video : 1 Vpp,75 Ohm Audio : 0.5 Vrms, >10 Kohm RGB
	AV1OUT	Video : 1 Vpp, 75 Ohm Audio : 0.5 Vrms, <1 Kohm
	AV2 IN (RCA, optional)	Video : 1 Vpp, 75 Ohm Audio : 0.5 Vrms, >10 Kohm
Operating temperature :	0-45 Degrees	
Safety :	IEC 65 /BS P2N	
X-Ray radiation :	ACC. IEC 65/BS P2N	

¹ : TV set is produced to receive "one" of these colour and sound systems.

3. REMOTE CONTROL

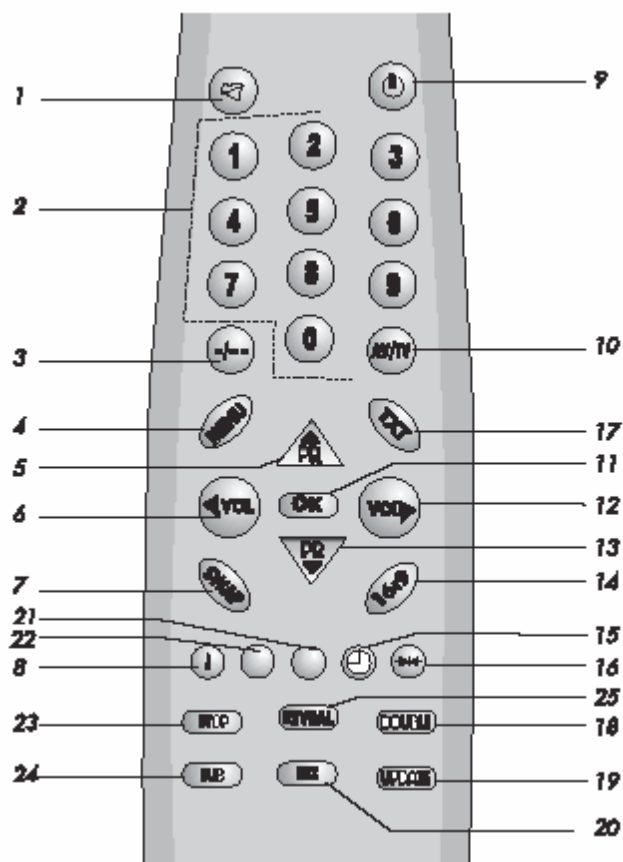

1. MUTE button
 2. Ten key program button
 3. Two digit program button (-/-)
 4. MENU button
 5. Program up button
 6. Volume decrease button
 7. Return to selected programme button (SWAP)
 8. Information button (i)
 9. STAND-BY button
 10. AV-TV selection button
 11. OK button
 12. Volume increase button
 13. Program down button
 14. 16:9 picture format button
 15. Sleep timer button
 16. Normalization button
- For Teletext Function (Opt.)**
1. Yellow fasttext button
 2. Blue fasttext button
 3. Teletext/TV select button
 4. Enlarge button
 5. UPDATE button
 6. MIX button
 7. Green fasttext button
 8. Red fasttext button
 9. STOP button
 10. SUB-PAGE button
 11. REVEAL button

Special features

- Automatic Programming
- 100 Programme Memory
- Available for Cable Channels (A decoder may be required)
- Manual Fine Tuning
- Skipping back to the last channel you have started to zapp via only one button(SWAP).
- 16:9 picture format
- Scart Socket: Video cassette recorder, satellite receiver, video disc player, DVD, TV games or a home computer can be connected to this AV socket with an appropriate connecting cable.
- Normalization system to recall the setting in memory after the colour, contrast, brightness setting have been changed.
- Automatic Volume Limiting.
- Infrared Remote Control.
- Your TV will automatically switch off if it's been programmed from 15 to 120 minutes.
- Automatically switch to Stand by five minutes after a channel ceases to transmit.
- Multi language menu system
- Naming the channels (Automatic with ATS).
- NTSC playback.
- S-VHS via Scart.
- ATS: Automatic Tuning System with country selection (*).
- Audio/Video RCA sockets (*).
- Headphone socket (*).
- Teletext reception (*).
- Zapping (*).
- I.P.S.: Intelligent Programme Switch: You can set your TV to skip to a specific Channel at a specific time. It works also as an alarm function (*).
- Childlock (*).
- Please Note: Zapping, I.P.S., Childlock are optional if ATS exists.

(*): These features are not available in all models.

4. PREPARATIONS

MAIN SUPPLY CONNECTIONS

Connect the TV mains plug into your domestic mains socket outlet (230 V 50Hz AC).

Press the Program up, Program down button or Numeric Buttons on the remote handset to switch the TV on.



AERIAL CONNECTION

Using a 75Ω aerial lead connect your TV to the aerial outlet in your home.

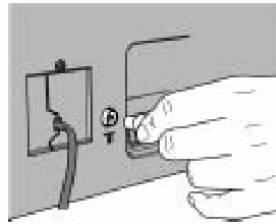

BATTERY FITTING

Insert the 2 AAA Batteries supplied into the compartment on the rear of the remote control, ensure you follow the polarity diagram inside the compartment.

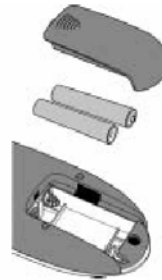

PIN CONNECTIONS FOR SCART SOCKET

- | | |
|----------------------------|-------------------------|
| 1- Audio output Right | 11- RGB input, Green |
| 2- Audio input Right | 12- |
| 3- Audio output Left(Mono) | 13- Red ground |
| 4- Audio ground | 14- Ground |
| 5- Blue ground | 15- RGB input, Red |
| 6- Audio input Left(Mono) | 16- Blanking Signal |
| 7- RGB input, Blue | 17- Video output ground |
| 8- Switching voltage | 18- Video input ground |
| 9- Green ground | 19- Video output |
| 10- | 20- Video input |
| | 21- Screening |

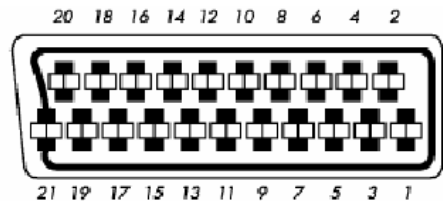

CONNECTING TV WITH VIDEO AND SATELLITE/DIGITALRECEIVER

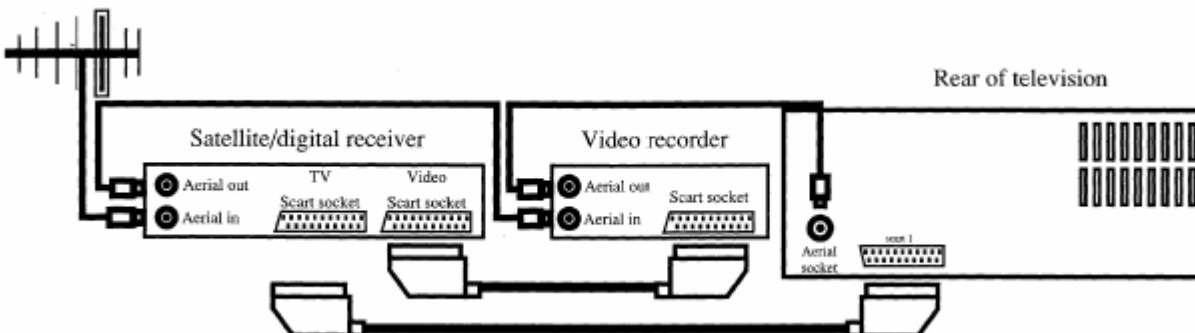

5. OPERATING YOUR TV

A. ZAPP FUNCTION (OPTIONAL)

Select the programme you would like to recall by pressing **SWAP** button. Selected programme number will appear on the upper left side of the screen. Watching any programme, you can recall the selected one by pressing **SWAP** button again. If you press **SWAP** button again, you can recall the last programme you watched. You can cancel ZAPP function by pressing INFO button.



Watching any programme, you can recall the selected one by pressing **SWAP** button again. If you press **SWAP** button again, you can recall the last programme you watched. You can cancel ZAPP function by pressing INFO button.

You can cancel ZAPP function by pressing INFO button.



B. SWAP FUNCTION

Allows you to swap between the program you are watching and the last selected program. i.e. If you were watching Program 1 and change to Program 11, press the SWAP button to go back to Program 1. Press it again to return to Program 11.



Press it again to return to Program 11.

Note: If Zapping function is available SWAP function will not work.



C. INFO

By pressing the “**WHITE (i)**” button the programme number and programme name (if it is exist) will appear on the screen. This will disappear automatically after a few seconds.



D. TUNING THE TELEVISION

There are two ways of tuning your television:

- Manual, where you control the tuning process or Autoprogram where the television does it all automatically.
- The TV sets equipped with ATS (Automatic Tuning System) sorts the channels regarding the broadcasting system of your country (optionally).

Please Note

If the TV is set to a channel with no signal the TV will return to standby after 5 minutes. The time remaining is displayed on the screen.

Manual Tuning

Tuning the TV is accessed through the SETUP menu.

To access the SETUP menu:

Press the MENU button twice. SETUP Menu will appear.

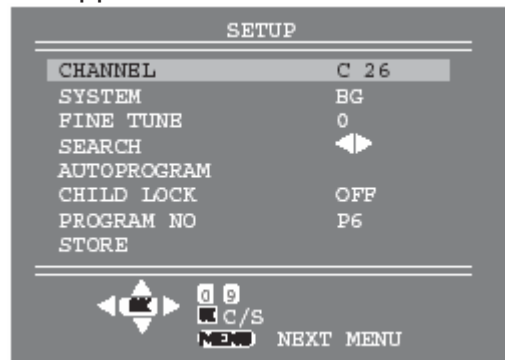

a) If you don't know the channel number (Tuning with **SEARCH** function).

Enter the SETUP menu by pressing MENU button twice.



In the SETUP Menu select PROGRAM NO and change to P1 using the Program down button to select it and the Volume up or Volume down button to change it.

Starting with Program P1, tune in the first channel as follows:



Use the Program up button to select SEARCH. Press the Volume up or Volume down button to start the tuning search. The search arrow will appear. When the search finds a strong searching. The picture will appear, channel signal it will stop.

Identify which channel you are watching (BBC 1, ITV 1 etc.) and decide which program number you want it to be.



Use the Program down button to select PROGRAM NO.

Use the Volume up/down buttons to select the program number.

Use the Program down button to select STORE. Press the OK button and STORED will appear on the STORE line.

You have now stored the first channel.

Use the Program up button to select again SEARCH and continue the tuning procedure until you have tuned in all the programmes you want or the television can receive.

b) If you know the channel number. (Tuning with channel numbers)



Press the OK button to select "S" for cable channels and "C" for terrestrial broadcast.

Use Volume up/down button to select the channel number or enter the channel number using the Numeric buttons.

Use the Program down button to select PROGRAM NO.



Enter the desired program number by using the Ten key program buttons

Use the Volume up/down buttons to select the program number.

Use the Program down button to select STORE. Press the OK button and STORED will appear on the STORE line. The channel will be stored with the program number you desired.

You have now stored the first channel.

Use the Program up button to select again CHANNEL and continue the tuning procedure until you have tuned in all the programmes you want or the television can receive.

To exit the SETUP menu press the TXT button.

Please note

The system will displayed automatically on SYSTEM row i.e.BG, L, I, DK depending the receiving broadcasting system of the country. In some countries the broadcasting system can be both in BG/DK or BG/LL'. Only the TV sets produced with Pal Secam BG/DK or Pal Secam BG/LL' systems can receive both BG/DK or BG/LL' broadcasts.

Please note

If you do not press any buttons for 15 seconds the TV will exit the menu system.

Automatic Tuning (Autoprogram)

Enter the SETUP menu as before.

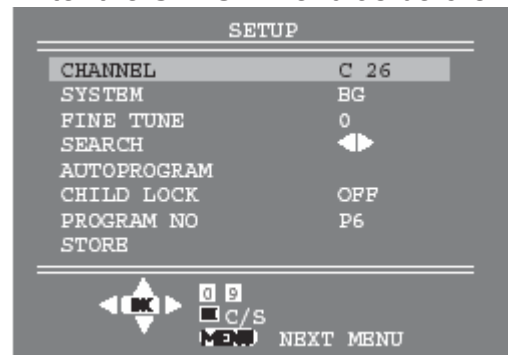



Use the Program down button to select AUTOPROGRAM and press the OK button.

Please Note:

a) On the TV sets equipped with ATS a COUNTRY SELECTION menu will appear.

Select the desired country using Program and Volume buttons.

Press the OK button to select the country and press the OK button again the Automatic Tuning System regarding the broadcasting system in the desired country.

b) On the TV sets without ATS pressing the OK button starts AUTOPROGRAM.



When you are sure the aerial is connected properly press the OK button and to confirm it press OK button again.

To cancel Autoprogram whilst it is working press the Menu button. As Autoprogram stores a channel it will appear briefly on the screen.

Your TV is now tuned and ready to use

E. TV SET UP

The TV set up is accessed through a menu system.

Once you have stored your set up, this is the set up the TV will default to when you switch it on.

Please note

If you do not press any buttons for 18-19 seconds the TV will exit the menu system.

There are three menus;

- Picture Menu
- Setup Menu
- Features Menu

• Picture Menu

To reach the picture menu press one time to MENU button.

- BRIGHTNESS
- CONTRAST
- COLOUR
- SHARPNESS



To change, for example, the colour, select it using Program down buttons.

Use the Volume up and Volume down buttons to change the setting.

To save your settings, select STORE and press the OK button. STORED will be displayed.

Note:

If you play NTSC formatted tape from the scart, the TINT menu will appear to adjust the TINT level.

• Set up Menu

Set up menu is explained above, under “Tuning the Television” topic

• Features Menu

To reach the feature menu press three times to MENU button.

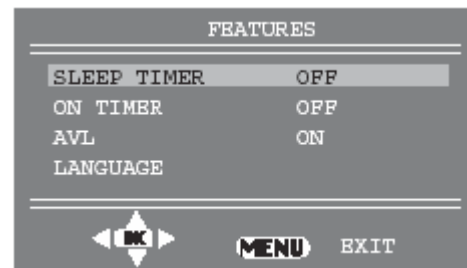

a) Sleep Timer

The sleep timer automatically switches the set to stand-by after the preset time has elapsed.

You can select the time from 15 to 120 minutes with 15 minutes steps.

There are two ways to set the sleep timer;

1- Select the SLEEP TIMER in the FEATURES menu. Select the desired time by using Volume down or Volume up buttons.

2- You can also use the YELLOW () button on your remote control to select this function. You can increase the switch off time interval by pressing this button repeatedly.

Notes:

The last 60 seconds of the desired switch off time by counting from 59 down. When this time interval has elapsed the set will switch to STAND-BY.

To view the remaining sleep time, press YELLOW () button. To cancel the sleep time select OFF in SLEEP TIMER.

b) On Timer

You can select the on time between 30 minutes to 12 hours by pressing numeric buttons or AV button.

If TV is at Stand-by position, you can switch it on at desired time and programme by activating the ON TIMER feature.

To cancel the on time select off in ON TIMER.

c) AVL

TV transmitters have different sound levels. AVL (automatic volume limiting) maintains the same sound level as you switch from program to program.

From the features menu you can select AVL button by pressing Program down button.

To supply this press Volume up or down button and select ON for AVL.

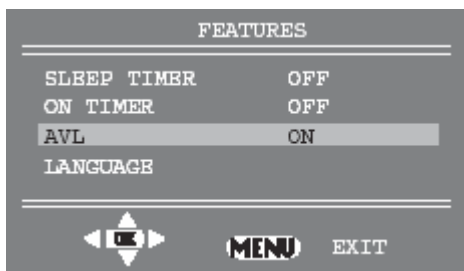

d) Language

There are many languages available for the On Screen Displays (OSD).



In the features menu select Language by program down button.

Press the OK button to select the language list.



Press the Program up/down or Volume up/down buttons to page through all the languages and OK to select.

E1 CHASSIS BLOCK DIAGRAM

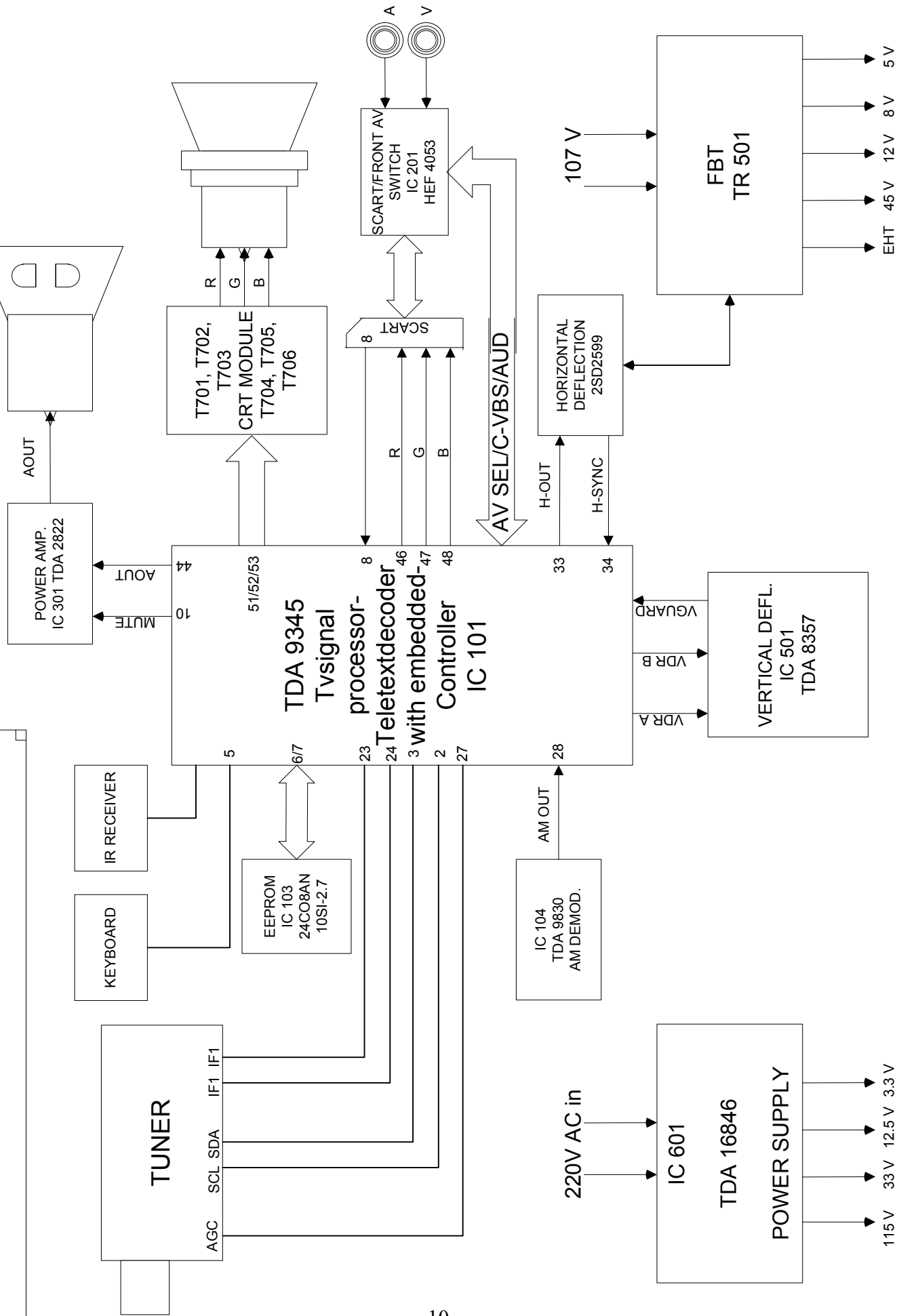

TDA 9345**GENERAL DESCRIPTION**

The various versions of the TDA9345 and TDA9345 PS-N3 combine the functions of a video processor together with a μ -Controller, a Teletext decoder and US Closed Caption decoder. The Teletext decoder has an internal RAM memory for 1 page(TDA 9345) or 10 page(TDA 9346) text. The ICs are intended to be used in economy television receivers with picture tubes up to 100°. The ICs have supply voltages of 8 V and 3.3 V and they are mounted in an SDIP-64 envelope. The features are given in the following feature list.

FEATURES**a) TV processor**

- Multi-standard vision IF circuit with alignment-free PLL demodulator
- Internal (switchable) time-constant for the IF-AGC circuit
- The mono intercarrier sound circuit has a selective FM-PLL demodulator which can be switched to the different FM sound frequencies (4.5/5.5/6.0/6.5 MHz). The quality of this system is such that the external band-pass filters can be omitted.
- Source selection between the 'internal' CVBS and an external CVBS or Y/C signal
- Integrated chrominance trap circuit
- Integrated luminance delay line with adjustable delay time
- Picture improvement features with peaking (with switchable centre frequency, depeaking, variable positive/negative overshoot ratio and video dependent coring) and blue- and black stretching. All features are available for CVBS, Y/C and YPBPR signals.
- Integrated chroma band-pass filter with switchable centre frequency
- Only one reference (12 MHz) crystal required for the μ -Controller, and the colour decoder
- Multi-standard colour decoder with automatic search system
- Internal base-band delay line
- Indication of the Signal-to-Noise ratio of the incoming CVBS signal
- A linear RGB/YUV/YPBPR input with fast blanking for external RGB/YUV sources. The synchronisation circuit can be connected to the incoming Y signal. The OSD signals are internally supplied from the μ -Controller decoder.

- RGB control circuit with 'Continuous Cathode Calibration', white point and black level off-set adjustment so that the colour temperature of the dark and the light parts of the screen can be chosen independently.
- OSD/Text gain reduction control
- Horizontal synchronization with two control loops and alignment-free horizontal oscillator
- Vertical count-down circuit
- Vertical driver optimized for DC-coupled vertical output stages
- Low-power start-up of the horizontal drive circuit
- Macrovision keying possibility for horizontal synchronisation.

b) μ -Controller

- 80C51 μ -controller core standard instruction set and timing
- 1 μ s machine cycle
- 32 - 64Kx8-bit(TDA9345) or 64-128Kx8-bit(TDA9346) late programmed ROM
- 3Kx8(TDA9345) or 12Kx8(TDA9346)-bit Auxiliary RAM (shared with Display)
- Interrupt controller for individual enable/disable with two level priority
- Two 16-bit Timer/Counter registers
- One 16-bit Timer with 8-bit Pre-scaler
- WatchDog timer
- Auxiliary RAM page pointer)
- 16-bit Data pointer
- Stand-by, Idle and Power Down modes
- 14 bits PWM for Voltage Synthesis Tuning
- 8-bit A/D converter
- 4 pins which can be programmed as general I/O pin, ADC input or PWM (6-bit) output

c) Data Capture

- Automatic selection between 625 WST/VPS on line 16 of VBI
- Real-time capture and decoding for WST Teletext in Hardware, to enable optimized μ -processor throughput
- Automatic detection of FASTEXT transmission
- Real-time packet 26 engine in Hardware for processing accented, G2 and G3 characters
- Signal quality detector for video and WST/VPS data types
- Comprehensive teletext language coverage
- Full Field and Vertical Blanking Interval (VBI) data capture of WST data
- Data Capture for US Closed Caption
- Data Capture for 525/625 line WST, VPS (PDC system A) and Wide Screen Signalling (WSS) bit decoding
- Automatic selection between 525 WST/625 WST
- In the 10 page versions inventory of transmitted Teletext pages stored in the Transmitted Page Table (TPT) and Subtitle Page Table (SPT)
- Text memory for 1 or 10 pages

d) Display

- Teletext and Enhanced OSD modes
- Features of level 1.5 WST and US Close Caption
- Serial and Parallel Display Attributes
- Single/Double/Quadruple Width and Height for characters
- Scrolling of display region
- Variable flash rate controlled by software
- Enhanced display features including overlining, underlining and italics
- Soft colours using CLUT with 4096 colour palette
- Globally selectable scan lines per row (9/10/13/16) and character matrix [12x10, 12x13, 12x16 (VxH)]
- Fringing (Shadow) selectable from N-S-E-W direction
- Fringe colour selectable
- Meshing of defined area
- Contrast reduction of defined area

- Cursor
- Special Graphics Characters with two planes, allowing four colours per character
- 32 software redefinable On-Screen display characters
- 4 WST Character sets (G0/G2) in single device (e.g. Latin, Cyrillic, Greek, Arabic)
- G1 Mosaic graphics, Limited G3 Line drawing characters
- WST Character sets and Closed Caption Character set in single device

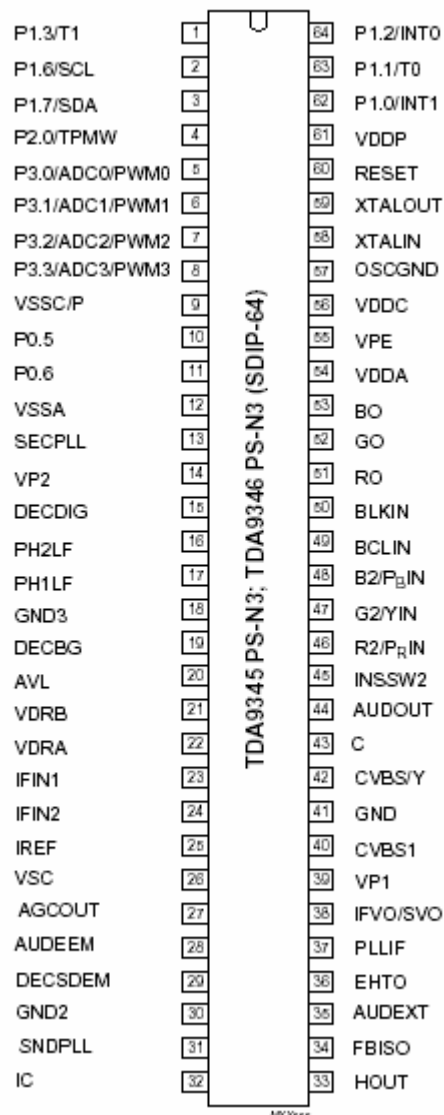

BLOCK DIAGRAM

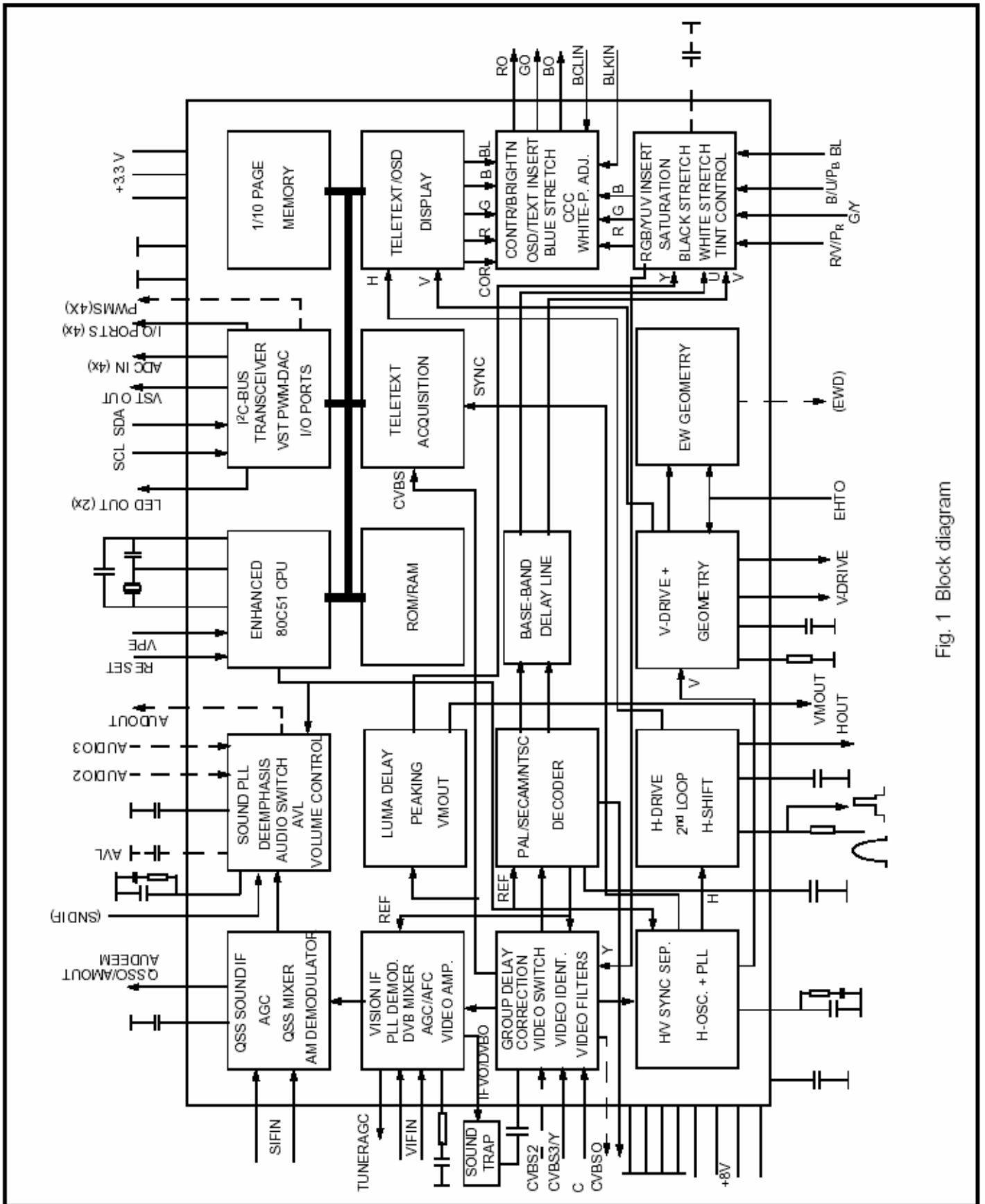
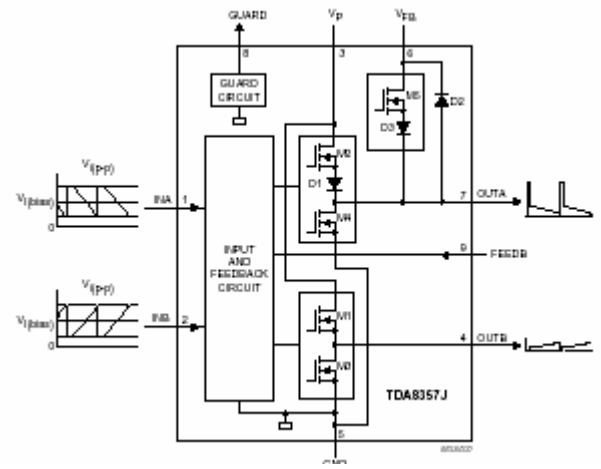

Fig. 1 Block diagram

TDA 8357J

GENERAL DESCRIPTION

The TDA8357J is a power circuit for use in 90° and 110° colour deflection systems for 25 to 200 Hz field frequencies, and for 4 : 3 and 16 : 9 picture tubes. The IC contains a vertical deflection output circuit, operating as a high efficiency class G system. The full bridge output circuit allows DC coupling of the deflection coil in combination with single positive supply voltages. The IC is constructed in a Low Voltage DMOS (LVDMOS) process that combines bipolar, CMOS and DMOS devices. DMOS transistors are used in the output stage because of absence of second breakdown.



FEATURES

- Few external components required
- High efficiency fully DC coupled vertical bridge output circuit
- Vertical flyback switch with short rise and fall times
- Built-in guard circuit
- Thermal protection circuit
- Improved EMC performance due to differential inputs

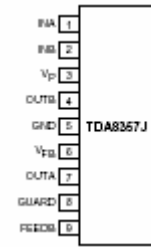

SYMBOL	PARAMETERS	CONDITIONS	MIN.	TYP.	MAX.	UNIT
Supplies						
Vp	Supply voltage		7.5	12	18	V
VFB	flyback supply voltage		2 x VP	45	66	V
Iq(P)(av)	average quiescent supply current	during scan	-	10	15	mA
Iq(FB)(av)	Iq(FB)(av)	during scan	-	-	10	mA
Ptot	total power dissipation		-	-	8	W
Inputs and outputs						
Vi(p-p)	input voltage (peak-to-peak value)		-	1000	1500	mV
Io(p-p)	output current (peak-to-peak value)		-	-	2.0	A
Flyback switch						
Io(peak)	maximum (peak) output current	t ≤ 1.5 ms	-	-	± 1.2	A
Thermal data; in accordance with IEC 60747-1						
Tstg	storage temperature		-55	-	+150	°C
Tj	junction temperature		-	-	+150	°C

TDA 2822

DESCRIPTION

The TDA2822 is a monolithic integrated circuit in 12+2+2 powerdip, intended for use as dual audio power amplifier in portable radios and TS sets.

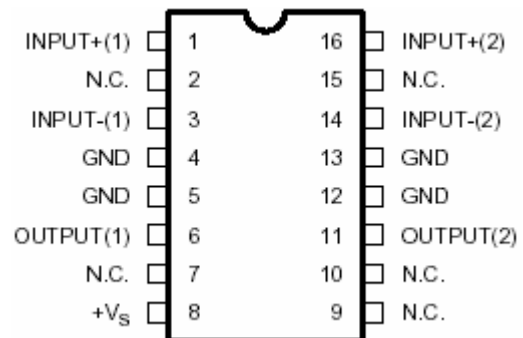

HEF 4053B

DESCRIPTION

The HEF4053B is a triple 2-channel analogue multiplexer/demultiplexer with a common enable input (E). Each multiplexer/demultiplexer has two independent inputs/outputs (Y0 and Y1), a common input/output (Z), and select inputs (Sn). Each also contains two-bidirectional analogue switches, each with one side connected to an independent input/output (Y0 and Y1) and the other side connected to a common input/output (Z). With E LOW, one of the two switches is selected (low impedance ON-state) by Sn. With E HIGH, all switches are in the high impedance OFF-state, independent of SA to SC. VDD and VSS are the supply voltage connections for the digital control inputs (SA to SC and E). The VDD to VSS range is 3 to 15 V. The analogue inputs/outputs (Y0, Y1 and Z) can swing between VDD as a positive limit and VEE as a negative limit. VDD-VEE may not exceed 15 V. For operation as a digital multiplexer/demultiplexer, VEE is connected to VSS (typically ground).

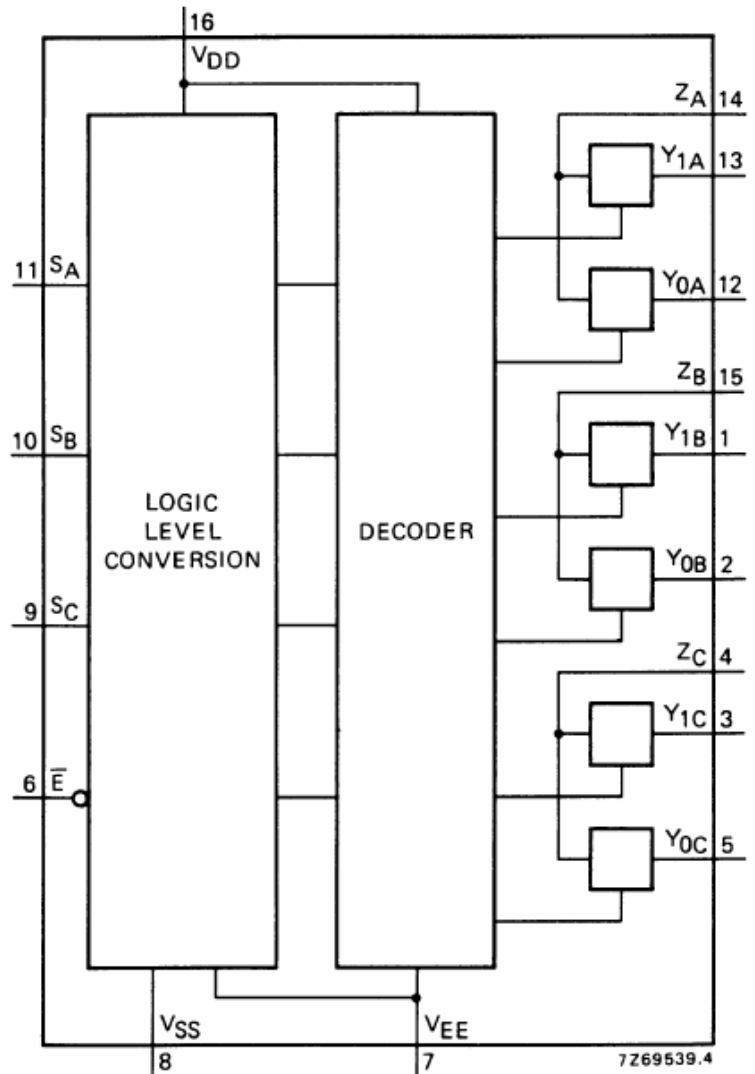
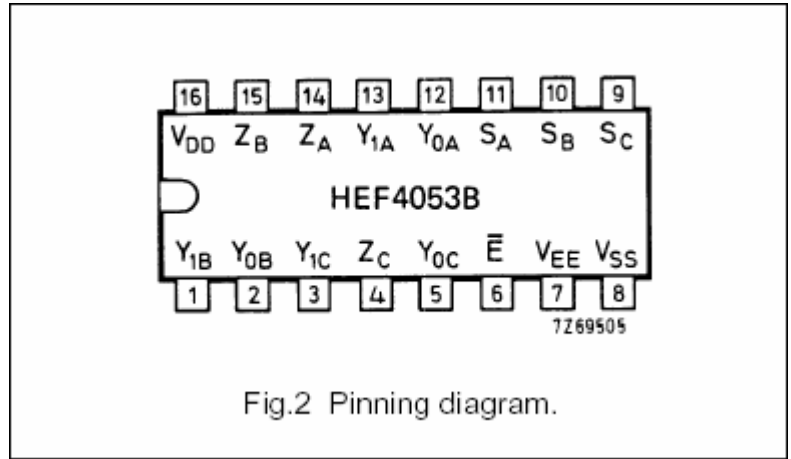

TDA 9830

TV sound AM-demodulator and audio source switch

SYMBOL	PIN	DESCRIPTION
IFIN	1	sound IF differential input signal
n.c.	2	not connected
CAGC	3	AGC capacitor
CREF	4	REF voltage filtering capacitor
n.c.	5	not connected
AMOUT	6	AM demodulator output
AMIN	7	input signal (from AM) to audio switch
AFOUT	8	output signal from audio switch
EXTIN	9	input signal (from external) to audio switch
SWITCH	10	switch input select control
Vp2	11	supply voltage +12 V (alternative)
MUTE	12	mute control
GND	13	ground (0 V)
Vp1	14	supply voltage +5 to +8 V
n.c.	15	not connected
IFIN	16	sound IF differential input signal

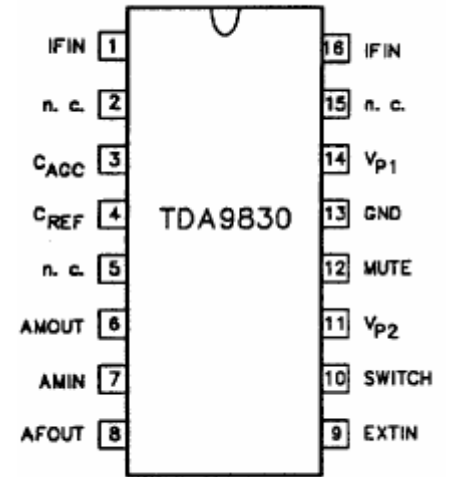

8. PIN VOLTAGES OF IC's

IC101(TDA 9345)							
TV signal processor-Teletext decoder with embedded Controller							
PIN	SYMBOL	DESCRIPTION	V DC(*)	PIN	SYMBOL	DESCRIPTION	V DC(*)
1	P1.3/T1	port 1.3 or Counter/Timer 1 input	2,46(2,4)	33	HOUT	horizontal output	0,88(3,12)
2	P1.6/SCL	port 1.6 or I2C-bus clock line	4,88(0)	34	FBISO	flyback input/sandcastle output	0,41(0)
3	P1.7/SDA	port 1.7 or I2C-bus data line	4,88(0)	35	AUDTEXT	external audio input	3,71(-0,06)
4	P2.0/TPMW	port 2.0 or Tuning PWM output	0,30(0)	36	EHTO	EHT/overvoltage protection input	1,72(0)
5	P3.0/ADC0/PWM0	port 3.0 or ADC0 input or PWM0 output	0,15(3,22)	37	PLLIF	IF-PLL loop filter	2,45(0)
6	P3.1/ADC0/PWM1	port 3.1 or ADC1 input or PWM1 output	2,48(0)	38	IFVO/SVO	IF video output / selected CVBS output	3,05(0)
7	P3.2/ADC0/PWM2	port 3.2 or ADC2 input or PWM2 output	1,65(1,62)	39	VP1	main supply voltage TV processor	8,12(0)
8	P3.3/ADC0/PWM3	port 3.3 or ADC3 input or PWM3 output	0(0)	40	CVBS1	internal CVBS input	3,79(0)
9	VSSC/P	digital ground for μ -Controller core and periphery	0(0)	41	GND	ground for TV processor	0(0)
10	P0.5	port 0.5 (8 mA current sinking capability for direct drive of LEDs)	0(2,72)	42	CVBS/Y	CVBS3/Y input	3,33(0)
11	P0.6	port 0.6 (8 mA current sinking capability for direct drive of LEDs)	0(0)	43	C	chroma input	1,54(0)
12	VSSA	digital ground of TV-processor	0(0)	44	AUDOUT	audio output	3,27(0)
13	SECPLL	SECAM PLL decoupling	2,28(0)	45	INSSW2	2nd RGB / YPRPB insertion input	0,03(0)
14	VP2	2nd supply voltage TV-processor (+8V)	8,15(0)	46	R2/P _R IN	2nd R input / PR input	2,54(0)
15	DECDIG	supply voltage decoupling of digital circuit of TV-processor	5,01(0)	47	G2/YIN	2nd G input / Y input	2,54(0)
16	PH2LF	phase-2 filter	2,56(0)	48	B2/P _B IN	2nd B input / PB input	2,54(0)
17	PH1LF	phase-1 filter	3,92(0)	49	BCLIN	beam current limiter input	2,28(0,32)
18	GND3	ground 3 for TV-processor	0(0)	50	BLKIN	black current input / V-guard input	7,13(0)
19	DECBG	bandgap decoupling	3,99(0)	51	RO	Red output	2,81(-0,03)
20	AVL	Automatic Volume Levelling	0,01(0,01)	52	GO	Green output	2,81(-0,03)
21	VDRB	vertical drive B output	0,94(0)	53	BO	Blue output	2,79(-0,03)
22	VDRA	vertical drive A output	0,98(0)	54	VDDA	analog supply of Teletext decoder and digital supply of TV-processor (3.3 V)	3,24(3,24)
23	IFIN1	IF input 1	1,85(0)	55	VPE	OTP Programming Voltage	0(0)
24	IFIN2	IF input 2	1,85(0)	56	VDDC	digital supply to core (3.3 V)	3,27(3,24)
25	IREF	reference current input	3,86(0)	57	OSCGND	oscillator ground supply	0,03(0)
26	VSC	vertical sawtooth capacitor	3,88(0)	58	XTALIN	crystal oscillator input	1,57(1,57)
27	AGCOUT	tuner AGC output	1,46(0)	59	XTALOUT	crystal oscillator output	1,66(1,62)
28	AUDEEM	Audio deemphasis	3,15(0)	60	RESET	reset	0(0)
29	DECSDEM	decoupling sound demodulator	2,21(0,28)	61	VDDP	digital supply to periphery (+3.3 V)	3,27(3,18)
30	GND2	ground 2 for TV processor	0(0)	62	P1.0/INT1	port 1.0 or external interrupt 1 input	3,58(3,48)
31	SNDPLL	narrow band PLL	2,21(0)	63	P1.1/T0	port 1.1 or Counter/Timer 0 input	3,29(3,24)
32	IC	internally connected	0,34(0)	64	P1.2/INT0	port 1.2 or external interrupt 0 input	3,29(3,24)

(*) Stand-by values are given the parenthesis

NOTE: The function of pin 15, 27, 33 and 48 is dependent on the mode of operation (mono intercarrier mode / QSS IF amplifier) and is controlled by some software control bits.3

IC301(TDA 2822)							
TV signal processor-Teletext decoder with embedded Controller							
PIN	SYMBOL	DESCRIPTION	V DC(*)	PIN	SYMBOL	DESCRIPTION	V DC(*)
1	INPUT +(1)	1st Input(Positive)	0(0)	9	N.C.	No Connection	0(0)
2	N.C.	No Connection	0(0)	10	N.C.	No Connection	0(0)
3	INPUT-(1)	1st Input(Negative)	0,5(0,5)	11	OUTPUT(2)	2nd Output	5,79(6,49)
4	GND	Ground	0(0)	12	GND	Ground	0(0)
5	GND	Ground	0(0)	13	GND	Ground	0(0)
6	OUTPUT(1)	1st Output	5,79(6,38)	14	INPUT-(2)	2nd Input(Negative)	0,5(0,5)
7	N.C.	No Connection	0(0)	15	N.C.	No Connection	0(0)
8	+V _s	Vcc; 12,5 V in this concept	12,41(13,83)	16	INPUT+(2)	2nd Input(Positive)	0(0)

9. OSCILLOGRAPHS OF SOME IC PINS

Note : A pattern Generator is connected to the TV (Colour Bar, sound 1 kHz)

9.1 TDA 9345-IC 101

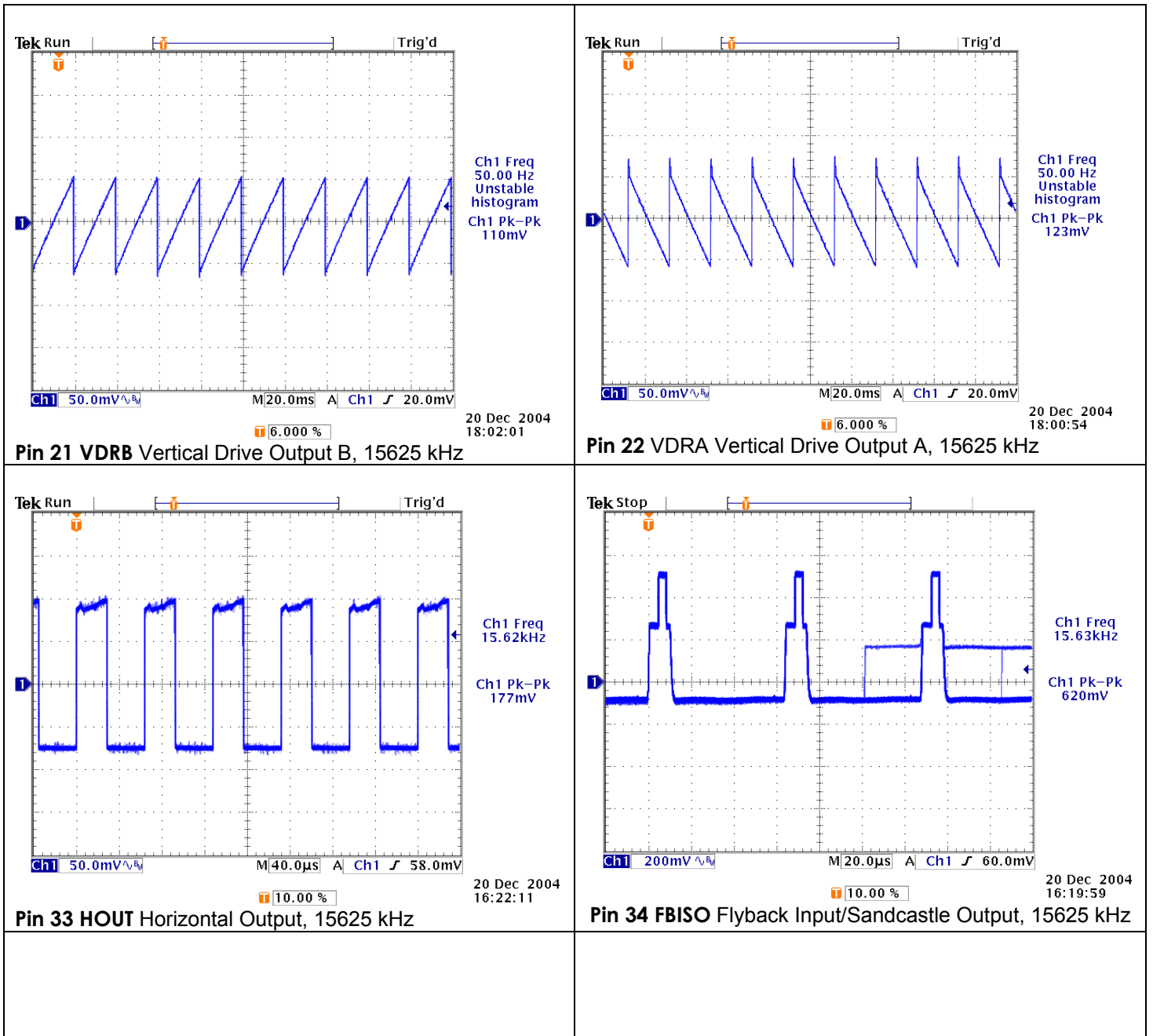

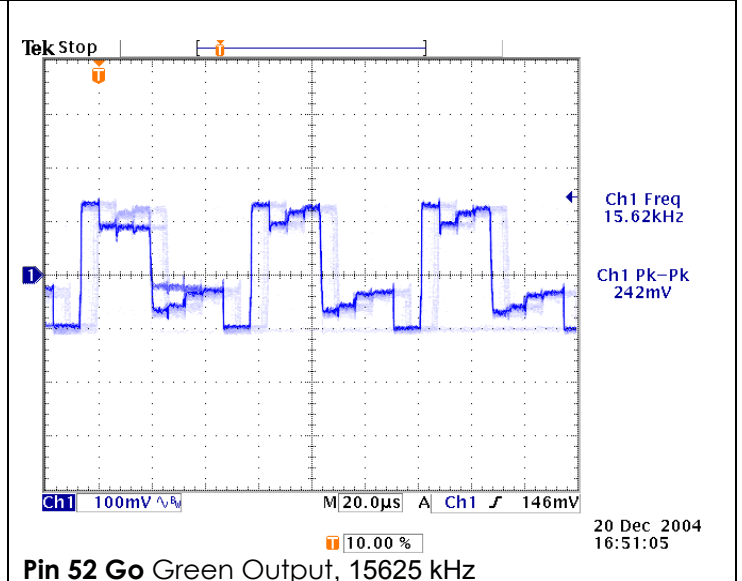
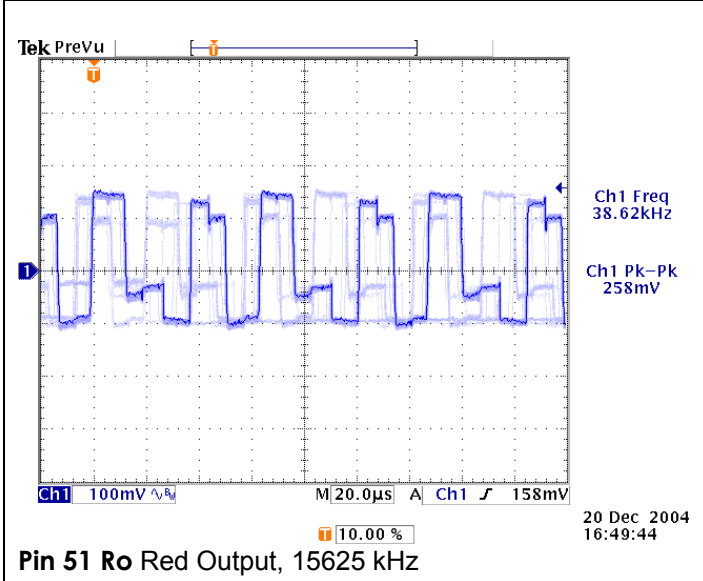
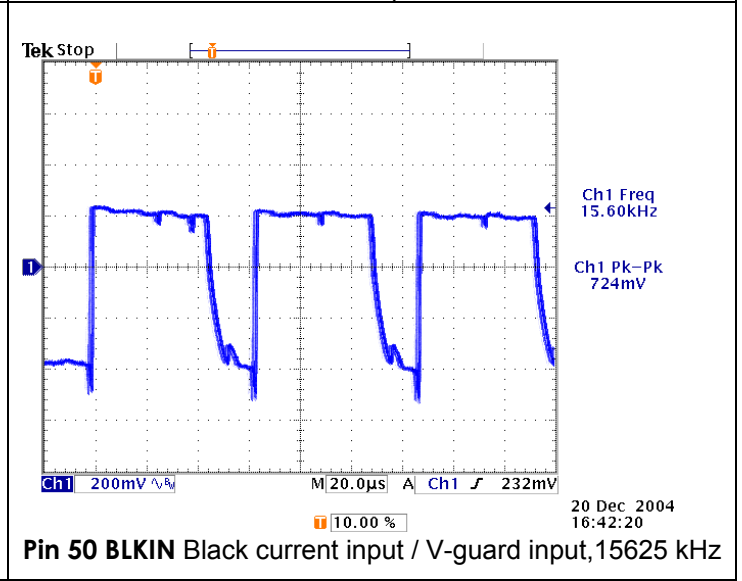
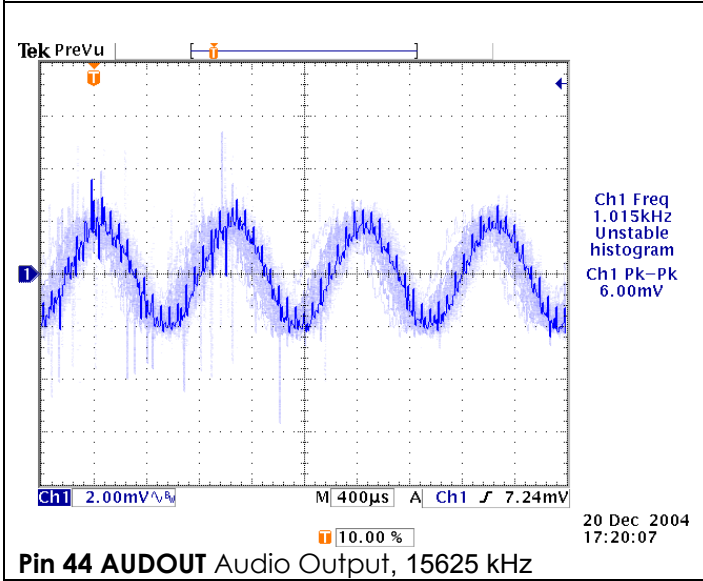
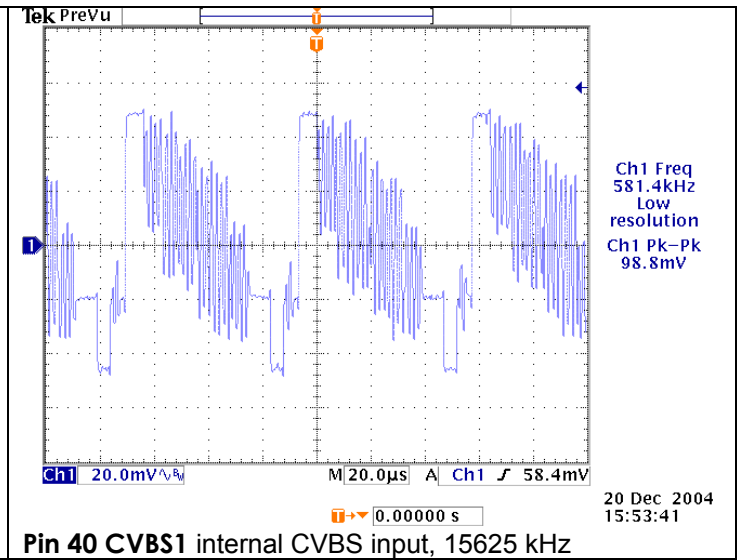
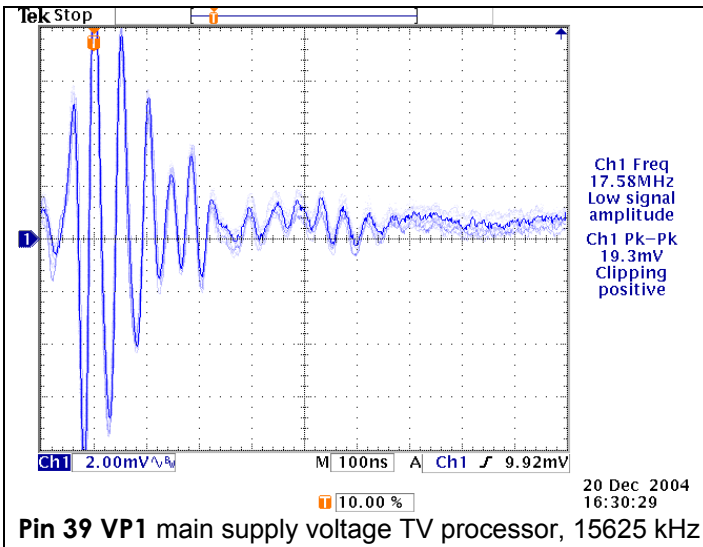

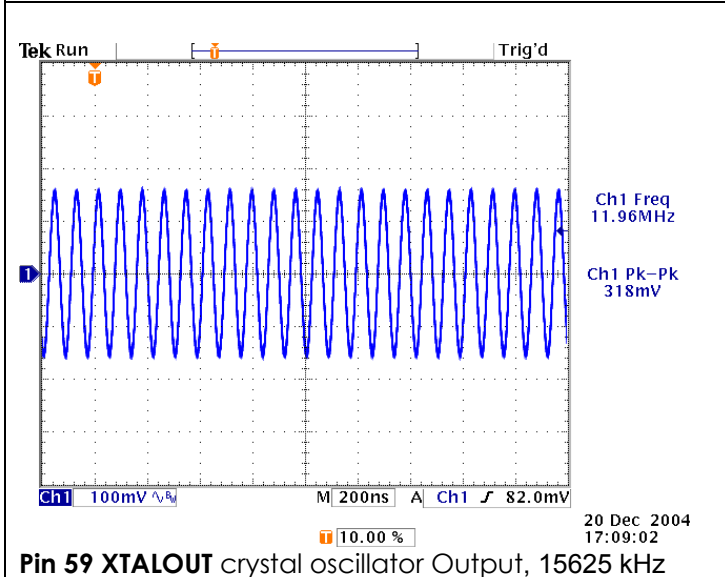
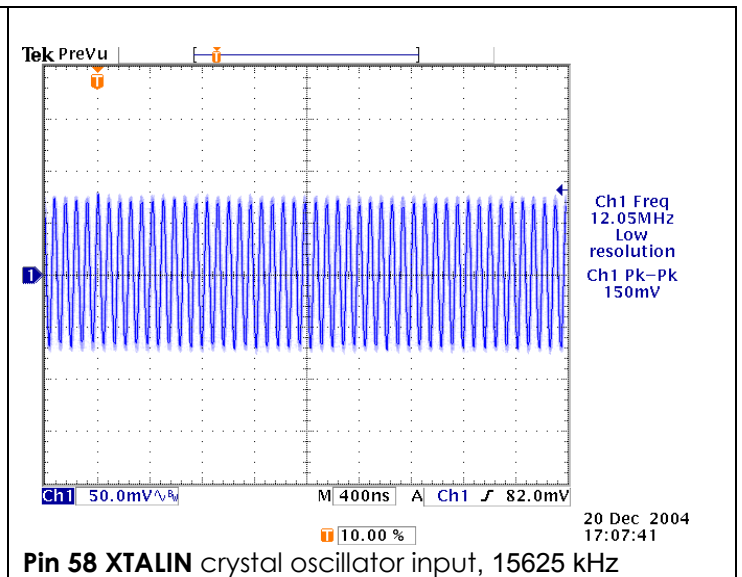
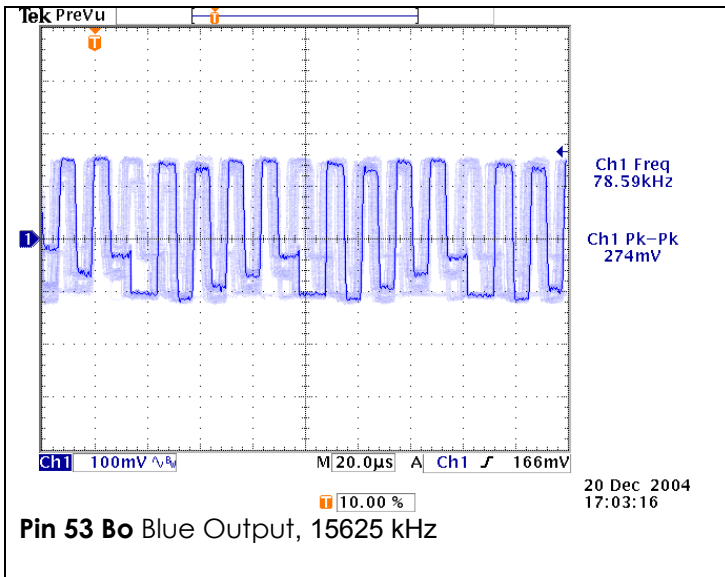

9.2 TDA 2822-IC 301

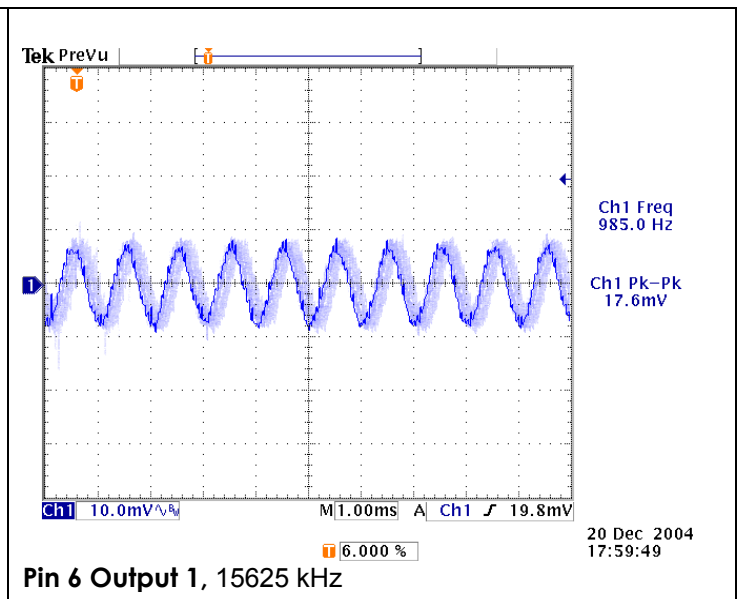
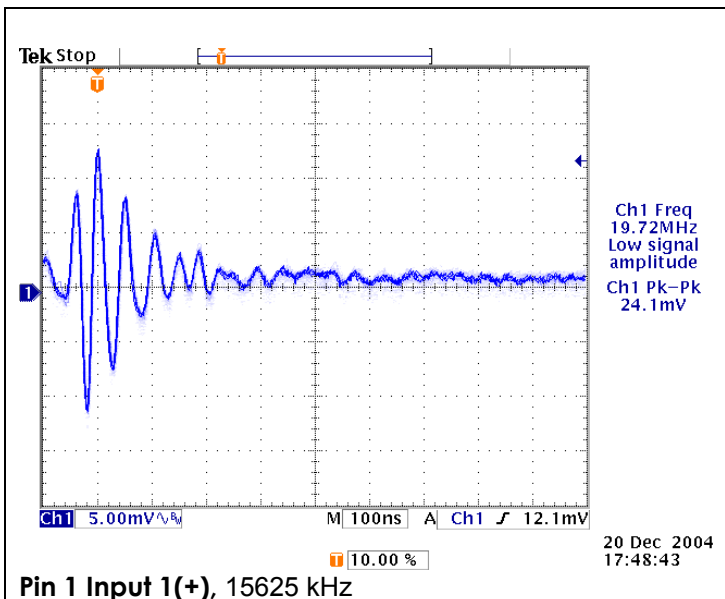

10. ELECTRICAL ADJUSTMENTS

1.1 Supply Voltage Adjustment

Connect a digital voltmeter to the cathode of diode D609 at the AV mode of the TV and set the screen voltage to the minimum with the screen potentiometer. Adjust the main supply voltage (B+) with P601 potentiometer to the following value (after supply adjustment, readjust Screen and focus voltage).

14"	: 105 VDC (for A34EAC01X06)
20"	: 112 VDC (for A48EAK02X101)
21"	: 110 VDC (for A51EFS13X191)

2. SERVICE ADJUSTMENTS

To enter the Service Mode, 'Service In/Out' button on the Service Remote Control or activate the "Picture Menu" with the user remote control and press "9301" (Press "0" button to exit the Service Mode).

While the service menu is on screen, version and the date of the software are written on right bottom of the screen.

For Example:

SE1.641-A01

07/26/04

12:57:37

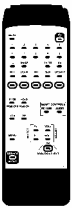

2.1 AGC Adjustment

- Switch on the Service Menu
- Find the "AGC(UHF)" with P+/P-
- Set its value to 30 for BG, BG/DK and I systems
- Find the "AGC(VHF)" with P+/P-
- Set its value to 30 for BG, BG/DK and I systems
- Find the "AGC(LPRIME)" with P+/P-
- Set its value to 20 for LL' system
- Exit from the service menu.

2.2 Screen Adjustment

- Switch the TV to the AV mode
- Do not make any connection from the scart switch
- Switch on the service menu
- Set the value of "BLUEBLACK" option to "OFF"
- Set the value of the "SCREEN ADJ." to "40"
- Press "OK" button on the RC
- There should appear a horizontal line on the center of the set
- Adjust the screen potentiometer to set the line at the first seen point.
- Exit from the service menu

2.3 White Balance Adjustment

- Apply a white pattern with a pattern generator to the antenna input.
- Enter the Service Menu and access to VIDEO sub-menu

- Set the value of "BLACK LEVEL G" and "WHITE POINT B" to "30" and "32" with V+ / V- buttons.
- Adjust "WHITE POINT R" and "WHITE POINT G" for red and green drives
- If white balance can not be adjusted properly slightly change the values of "BLACK LEVEL G" and "WHITE POINT B".
- Exit from Service menu.

2.4 Geometry Adjustments

- Apply the cross hatch pattern with a pattern generator to the antenna input.
- Enter Service Menu and access to GEOMETRY sub-menu
- Adjust Vertical Amplitude with "VER.AMPLITUDE" option.
- Adjust vertical centring with "VER.SHIFT", raster centring with "VER.SLOPE", vertical linearity with "S-CORRECTION" and horizontal centring with "HOR.SHIFT".
- Adjust the vertical amplitude for 16:9 mode with "VER.AMP.16:9"
- Adjust the centring of the OSD Menu with "HOR.OSD.POS" and "VER.OSD.POS".
- Adjust the contrast of the OSD and Teletext with "OSD CON" and "TXT CON"
- Exit from the Service Menu.

2.7 Options Menu

Enter the Service Menu with the Service RC and access to OPTION sub-menu and check the adjusted values are same as below.

TUNER : Phillips, Sharp&Alps, Panasonic, Temic.
 Note : Select Sharp&Alps when Samsung tuner is used.

ACG(UHF) : Automatic Gain Control for UHF Band
 ACG(VHF) : Automatic Gain Control for VHF Band
 AGC(LPRIME) : Automatic Gain Control for SECAM LL' Systems.
 TYPE : Label(sorts according to the catching order), ATS(Automatic Tuning System)
 STANDBY : CUSTOMER MODE (the units starts up in St.by mode,default value),
 FACTORY MODE(the unit directly goes to ON mode, can be used during repair)

AV1 SVHS : ON(SHVS from Scart one is available), OFF
 AV2 : ON(Scart 2 is available), NO
 SOUND : BG, I, BG+DK, BG+LL'
 BG : Europe, New Zeland, Australia
 TEXT : NON-TEXT, FASTEXT
 ON TIMER : ON(available) OFF(unavailable)
 4-KEY : INTERNAL(), EXT.3 KEY(front panel with 3 button), EXT.4KEY(front panel with 4 button)
 BLUEBLACK : ON(blueblack acticated), OFF(Blueblack inactivated)
 AUTO WSS : ON(Autosense of Widescreen), OFF
 CHILD LOCK : ON(hinders children access), OFF
 ZAPP : ON(Zapp available), OFF
 PROTECTION : The period of getting into protection
 SIMPLE HOTEL : ON(Hotel mode, available), OFF
 MAX VOLUME : Used for Hotel Mode, limits the max volume in hotel mode
 RGBIN : ON (When Scart RGB exists, aerial isn't showed-for only for some Hotel TVs), NO (Default)

2.7 Hotel Mode

If "Simple Hotel" option in the Service Menu is selected as "ON", to access set up menu "4658" should be typed whilst the "Features Menu" is on screen. After finishing the adjustments by taking the TV to St.by or shutting down, the access can be re-inhibited.

2.7 Factory Settings for Service Mode

Values given in Table 1 are typical values and can vary according to the CRT type.

		14"	15"	20"	21"
AGC(UHF)	Automatic Gain Control 1(UHF)	30	30	30	30
AGC(VHF)	Automatic Gain Control 2(VHF)	30	30	30	30
AGC(LPRIME)	Automatic Gain Control for SECAM LL'	20	20	20	20
STANDBY	Stand By	Fac. Mode	Fac. Mode	Fac. Mode	Fac. Mode
VER.AMPL*	Vertical Amplitude	46	36	03	03
VER.SHIFT*	Vertical Shift	28	31	33	33
VER.SLOPE*	Vertical Slope	28	32	32	32
S-CORRECT*	S Correction	24	30	30	30
HOR.SHIFT*	Horizontal Shift	41	30	34	34
VER AMP 16:9*	Vertical Amplitude for 16:9 Mode	11	00	12	12
YC DELAY PAL	YC Delay Pal	07	07	07	07
YC DELAY SECAM	YC Delay Secam	07	07	07	07
YC DELAY NTSC	YC Delay NTSC	07	07	07	07
HOR.OSD POS*	Horizontal OSD Position	41	37	37	37
VER.OSD POS*	Vertical OSD Position	07	04	04	04
OSD CON	OSD Contrast	06	06	06	06
TXT CON	Teletext Contrast	00	00	00	00
TXT BRI	Teletext Brightness	30	30	30	30
PWL	Peak White Limiting	08	08	08	08
CATH.DRV.LEV	Cathode Drive Level	07	08	10	10
BLACK LEV R	Black level offset red	36	32	19	19
BLACK LEV G	Black level offset green	30	32	27	27
WHITE POINT R	White Point Red	42	32	32	32
WHITE POINT G	White Point Green	41	32	32	32
WHITE POINT B	White Point Blue	32	33	32	32

Table 1

2.8 Exit from Service Menu

To exit from the service menu, TV/TX button should be typed on the Remote Control.

11. CHANNEL FREQUENCY TABLE

CHANNEL FREQUENCY TABLE (BG,I,DK,LL')

CHANNEL NO	BG	I	DK	L/L'			
CH1		49.75	49.75	47.75			
CH2	48.25	59.25	59.25	55.75			
CH3	55.25	77.25	77.25	60.50			
CH4	62.25	85.25	85.25	63.75			
CH5	175.25	93.25	93.25	176.00			
CH6	182.25	175.25	175.25	184.00			
CH7	189.25	183.25	183.25	192.00			
CH8	196.25	191.25	191.25	200.00			
CH9	203.25	199.25	199.25	208.00			
CH10	210.25	207.25	207.25	216.00			
CH11	217.25	215.25	215.25	189.25			
CH12	224.25	223.25	223.25	182.25			
CH13	53.75	45.75		196.25			
CH14	62.25	53.75		210.25			
CH15	82.25	61.75					
CH16	175.25	69.75					
CH17	183.25	95.25					
CH18	192.25						
CH19	201.25						
CH20	210.25						
CH21	471.25	471.25	471.25	471.25			
CH22	479.25	479.25	479.25	479.25			
CH23	487.25	487.25	487.25	487.25			
CH24	495.25	495.25	495.25	495.25			
CH25	503.25	503.25	503.25	503.25			
CH26	511.25	511.25	511.25	511.25			
CH27	519.25	519.25	519.25	519.25			
CH28	527.25	527.25	527.25	527.25			
CH29	535.25	535.25	535.25	535.25			
CH30	543.25	543.25	543.25	543.25			
CH31	551.25	551.25	551.25	551.25			
CH32	559.25	559.25	559.25	559.25			
CH33	567.25	567.25	567.25	567.25			
CH34	575.25	575.25	575.25	575.25			
CH35	583.25	583.25	583.25	583.25			
CH36	591.25	591.25	591.25	591.25			
CH37	599.25	599.25	599.25	599.25			
CH38	607.25	607.25	607.25	607.25			
CH39	615.25	615.25	615.25	615.25			
CH40	623.25	623.25	623.25	623.25			
CH41	631.25	631.25	631.25	631.25			
CH42	639.25	639.25	639.25	639.25			
CH43	647.25	647.25	647.25	647.25			
CH44	655.25	655.25	655.25	655.25			
CH45	663.25	663.25	663.25	663.25			
CH46	671.25	671.25	671.25	671.25			
CH47	679.25	679.25	679.25	679.25			
CH48	687.25	687.25	687.25	687.25			
CH49	695.25	695.25	695.25	695.25			
CH50	703.25	703.25	703.25	703.25			
CH51	711.25	711.25	711.25	711.25			
CH52	719.25	719.25	719.25	719.25			
CH53	727.25	727.25	727.25	727.25			
CH54	735.25	735.25	735.25	735.25			
CH55	743.25	743.25	743.25	743.25			
CH56	751.25	751.25	751.25	751.25			
CH57	759.25	759.25	759.25	759.25			
CH58	767.25	767.25	767.25	767.25			
CH59	775.25	775.25	775.25	775.25			

CH60	783.25	783.25	783.25	783.25			
CH61	791.25	791.25	791.25	791.25			
CH62	799.25	799.25	799.25	799.25			
CH63	807.25	807.25	807.25	807.25			
CH64	815.25	815.25	815.25	815.25			
CH65	823.25	823.25	823.25	823.25			
CH66	831.25	831.25	831.25	831.25			
CH67	839.25	839.25	839.25	839.25			
CH68	847.25	847.25	847.25	847.25			
CH69	855.25	855.25	855.25	855.25			
CH70				863.25			
CH71							
CH72							
CH73							
CH74	69.25						
CH75	76.25						
CH76	83.25						
CH77	90.25						
CH78	97.25						
CH79	59.25						
CH80	93.25						
S1	105.25	103.25	103.25	116.75			
S2	112.25	111.25	111.25	128.75			
S3	119.25	119.25	119.25	140.75			
S4	126.25	127.25	127.25	152.75			
S5	133.25	135.25	135.25	164.75			
S6	140.25	143.25	143.25	176.75			
S7	147.25	151.25	151.25	188.75			
S8	154.25	159.25	159.25	200.75			
S9	161.25	167.25	167.25	212.75			
S10	168.25	231.25	231.25	224.75			
S11	231.25	239.25	239.25	236.75			
S12	238.25	247.25	247.25	248.75			
S13	245.25	255.25	255.25	260.75			
S14	252.25	263.25	263.25	272.75			
S15	259.25	271.25	271.25	284.75			
S16	266.25	279.25	279.25	296.75			
S17	273.25	287.25	287.25	55.75			
S18	280.25	295.25	295.25	60.50			
S19	287.25	303.25	303.25	63.75			
S20	294.25						
S21	303.25			303.25			
S22	311.25	311.25	311.25	311.25			
S23	319.25	319.25	319.25	319.25			
S24	327.25	327.25	327.25	327.25			
S25	335.25	335.25	335.25	335.25			
S26	343.25	343.25	343.25	343.25			
S27	351.25	351.25	351.25	351.25			
S28	359.25	359.25	359.25	359.25			
S29	367.25	367.25	367.25	367.25			
S30	375.25	375.25	375.25	375.25			
S31	383.25	383.25	383.25	383.25			
S32	391.25	391.25	391.25	391.25			
S33	399.25	399.25	399.25	399.25			
S34	407.25	407.25	407.25	407.25			
S35	415.25	415.25	415.25	415.25			
S36	423.25	423.25	423.25	423.25			
S37	431.25	431.25	431.25	431.25			
S38	439.25	439.25	439.25	439.25			
S39	447.25	447.25	447.25	447.25			
S40	455.25	455.25	455.25	455.25			
S41	463.25	463.25	463.25	463.25			

POSITION NO	DECRPTION	PART NO	NOTES
C0001-C0002	C-PEM 220NF J 100V R:5	274230	
C0003	CC 220PF K 50V NPO R:5	201222	
C0004	CC 220PF K 50V NPO R:5	201222	
C01	C-ELA 47UF M 6.3V 11*5 R:5	251487	
C02-C03	CC-CHIP 100PF J 50V /1206 NPO	291101	
C101-C104	CC-CHIP 10NF K 50V /0603 X7R	293113	
C105	EC 10UF 63V 11*5 R:5	251116	
C106	CC-CHIP 100NF K 16V /0603 X7R	294118	
C107-C108	CC-CHIP 47PF J 50V /0603 NPO TAPE	290475	
C109	CC-CHIP 1NF K 50V /0603 X7R	292114	
C112-C114	CC-CHIP 100PF J 50V /0603 NPO	291104	
C115	EC 47UF 16V 11*5 R:5	251478	
C116	EC 4.7UF 50V 11*5 R:5	250479	
C118	EC 47UF 16V 11*5 R:5	251478	
C119	CC-CHIP 470NF K 16V /0805 X7R	294476	
C122	CC-CHIP 100NF K 50V /0805 X7R	294109	
C128	CC-CHIP 47PF J 50V /0603 NPO TAPE	290475	
C129	CC-CHIP 47PF J 50V /0603 NPO TAPE	290475	
C131-C132	EC 10UF 63V 11*5 R:5	251116	
C133	EC 1UF 50V 11*5 R:5	250115	
C134	EC 2.2UF 50V RS 11*5 R:5 TAPING	250220	
C135-C137	EC 100UF 16V 11*6 R:5	252112	
C138	CC-CHIP 10NF K 50V /0603 X7R	293113	
C139	CC-CHIP 100NF K 16V /0603 X7R	294118	
C140	CC-CHIP 100NF K 50V /0805 X7R	294109	
C141	C-PEM 100NF J 100V R:5	274107	
C142	CC-CHIP 100NF K 16V /0603 X7R	294118	
C143	CC-CHIP 100NF K 50V /0805 X7R	294109	
C144	CC-CHIP 100NF K 50V /0805 X7R	294109	
C145	CC-CHIP 100NF K 16V /0603 X7R	294118	
C146	CC-CHIP 100NF K 50V /0805 X7R	294109	
C148	CC-CHIP 4.7NF K 50V /0603 X7R	292475	
C149	CC-CHIP 3.3NF K 50V /0603 X7R TAPE	292336	
C150-C151	CC-CHIP 1NF K 50V /0603 X7R	292114	
C152	C-PEM 1NF K 50V R:5	272101	
C153	CC-CHIP 1NF K 50V /0603 X7R	292114	
C154	CC-CHIP 2.2NF K 50V/0603 X7R	292228	
C155	CC-CHIP 220NF K 16V /0805 X7R	294231	
C156	CC-CHIP 220NF K 16V /0805 X7R	294231	
C158	EC 2.2UF 50V RS 11*5 R:5 TAPING	250220	
C159-C163	CC-CHIP 47NF K 25V /0603 X7R TAPE	293478	
C164	EC 1UF 50V 11*5 R:5	250115	
C165	CC-CHIP 33PF J 50V /0603 NPO TAPE	290335	
C166	CC-CHIP 68PF J 50V /0603 NPO TAPE	290688	
C167	EC 100UF 16V 11*6 R:5	252112	
C168	CC-CHIP 100PF J 50V /0603 NPO	291104	
C169	CC-CHIP 220PF J 50V /0603 NPO TAPE	291226	
C170	EC 47UF 16V 11*5 R:5	251478	
C174	EC 4.7UF 50V 11*5 R:5	250479	
C175	CC-CHIP 4.7NF K 50V /0603 X7R	292475	
C176	CC-CHIP 820PF J 50V /0805 NP0	291822	
C201	EC 10UF 63V 11*5 R:5	251116	
C203	EC 47UF 16V 11*5 R:5	251478	
C205-C207	CC-CHIP 220PF J 50V /0603 NPO TAPE	291226	
C208-C212	CC-CHIP 1NF K 50V /0603 X7R	292114	
C213	CC-CHIP 470PF J 50V /0603 NP0 T&R	291476	
C214	CC-CHIP 470PF J 50V /0603 NP0 T&R	291476	
C215-C216	EC 2.2UF 50V RS 11*5 R:5 TAPING	250220	

POSITION NO	DECRPTION	PART NO	NOTES
C217	CC-CHIP 10NF K 50V /0603 X7R	293113	
C218	EC 4.7UF 50V 11*5 R:5	250479	
C219	CC-CHIP 100NF K 16V /0603 X7R	294118	
C220	EC 10UF 63V 11*5 R:5	251116	
C301	CC-CHIP 10NF K 50V /0603 X7R	293113	
C302	CC-CHIP 2.2NF K 50V/0603 X7R	292228	
C303	CC-CHIP 10NF K 50V /0603 X7R	293113	
C304-C305	CC-CHIP 100NF K 16V /0603 X7R	294118	
C306	EC 10UF 63V 11*5 R:5	251116	
C307	EC 220UF 25V 11*8 R:5	252225	
C308-501	CC-CHIP 470NF K 16V /0805 X7R	294476	
C502	EC 100UF 16V 11*6 R:5	252112	
C503	C-PEM 10NF K 100V R:5	273105	
C506	CC-CHIP 1NF K 50V /0603 X7R	292114	
C507-C508	CC-CHIP 2.2NF K 50V/0603 X7R	292228	
C510-C512	EC 100UF 16V 11*6 R:5	252112	
C514	C-PPM 8.2NF %3.5 1.5/1.6KV R:15 CLASS-B	272822	
C515-C516	CC-CHIP 100NF K 50V /0805 X7R	294109	
C517	EC 100UF-M 35V 12*8 R:5	252238	
C518	EC 10UF 63V 11*5 R:5	251116	
C519	C-PEM 1NF J 100V R:5	272110	
C520	C-PEM 47NF K 63V R:5	273471	
C521	EC 4.7UF 160V 11*6.3 R:5	239490	
C522	CC 68PF J 500V NPO R:5	200680	
C523	C-PPM 390NF J 250V R:15 CLASS-B	271390	
C524	CC 560PF 500V TAPE R:5	221571	
C525	EC 470UF 25V 11*10 R:5	252476	
C526	C-PEM 100NF J 100V R:5	274107	
C527	EC 47UF 63V 11*6.3 R:5	251475	
C528	EC 1000UF 16V 20*10 R:5	253115	
C529-C530	CC-CHIP 100NF K 50V /0805 X7R	294109	
C532	CC-CHIP 2.2NF K 50V/0603 X7R	292228	
C602-C604	CC-CHIP 47NF K 25V /0603 X7R TAPE	293478	
C605-C606	CC-CHIP 10NF K 50V /0603 X7R	293113	
C608	C-PPM 10NF K 275 VAC R:10	273115	
C609-C610	CC 1NF K 1KV Y5P R:5	202105	
C612	C-PPM 33NF J 630V R:15	203330	
C613	CC 220PF K 2KV Y5P R:5	201226	
C614	C-ELA 47UF 160V 21*13 R:5	251489	
C615	C-ELA 33UF 160V 21*10 R:5	251337	
C616	CC-CHIP 560PF J 50V /0603 NPO TAPE	291561	
C617	CC-CHIP 56PF J 50V/0603 NPO TAPE	290562	
C618	CC-CHIP 1.5NF K 50V /0603 X7R TAPE	292153	
C620	CC-CHIP 2.2NF K 50V/0603 X7R	292228	
C621	C-PPM 330NF K 275V-AC R:22.5 CLASS-B	274342	
C622	C-PEM 100NF M 275V-AC R:15 CLASS-B	△ 274119	
C624	EC 1UF 50V 11*5 R:5	250115	
C625	EC 22UF-M 50V 11*5 R:5	251221	
C626	C-ELA 68UF 400V 25*22 R:10	251681	
C628	CC 470PF K 2KV +15%, -30% 105C R:5	201481	
C629	CC 2.2NF M 250VAC Y5U R:10 AH/NSA	△ 202220	
C630	EC 220UF 16V 11*8 105 R:5	252223	
C631	EC 1000UF 25V 20*13 R:5	253106	
C632-C633	EC 47UF 16V 11*5 R:5	251478	
C634	CC-CHIP 47PF J 50V /0603 NPO TAPE	290475	
C635	CC 2.2NF M 250VAC Y5U R:10 AH/NSA	202220	
C636	CC-CHIP 100NF K 50V /0805 X7R	294109	
C701-C703	CC-CHIP 47PF J 50V /0603 NPO TAPE	290475	

POSITION NO	DECRPTION	PART NO	NOTES
C704-C706	CC-CHIP 390PF J 50V /0603 NPO TAPE	291393	
C707	EC 10UF 250V 16*10 R:5	251109	
C708-C710	CC-CHIP 470PF J 50V /0603 NP0 T&R	291476	
C711	C-CE 2.2NF K 2KV Y5P R:7.5	202221	
C712	C-PEM 100NF J 250V R:10	274105	
D01	LED IR SIR563SB3F 23/940	303991	
D101	LED L-513LR1D KIRM. L=25.4 (PARALIGHT)	303295	
D104-D107	DIODE 1N4148 52MM	302289	
D502-D509	DIODE 4148 MELF SOD-80C	303195	
D510-D604	DIODE BA157	300305	
D605-D608	DIODE RF2007	303308	
D609	DIODE RGP15J	303227	
D610-D611	DIODE RGP10J	303217	
D612	DIODE RGP15J	303227	
D701	DIODE 1N4148 52MM	302289	
D702	DIODE 4148 MELF SOD-80C	303195	
D703	DIODE 1N4148 52MM	302289	
D704	DIODE 1N4007	302948	
D980	LED LTL4221N D:3 R/D RED	303993	
F102	SAW FILTER OFW G1985M	56749	
F103	SER.FILTER TPSRA5M50B00-A0	56734	
F601	FUSE HOLDER, TK79A PLA	30402	
F601	FUSE 3.15AT (215)	54280	
IC	IC TDA8357 J	452975	
IC01	IC-CHIP S3C1840DA9/SMB1 T&R	452382	
IC101	IC TDA9345-N3	453433	
IC102	IR RECEIVER TSOP34838 SS1A	452521-01	
IC103	IC-CHIP AT24C08AN-10SI-2.7 (ATMEL) TAPE&	453031-02	
IC201	IC 4053B CMOS 16SOIC	452510	
IC301	IC TDA2822	452439	
IC601	IC TDA16846	452795	
IC602	IC-CHIP NCP1117DT33RK TO-252 PACKAGE	453124	
L0001	CHOKO COIL 50MHZ 600R PH-WBC3/R-3B1	55139	
L0002	CHOKO COIL 50MHZ 600R PH-WBC3/R-3B1	55139	
L0003	COIL 10UH K (TAIYO) LAL03	53711	
L102-L109	COIL 10UH K (TAIYO) LAL03	53711	
L110	COIL-CHIP 1UH K /0805	53805	
L502	TRANSFORMER HORIZONTAL DRIVE E1	51839	
L503	COIL H-LIN 55UH NEOSID	051591-10	
L601	LINE FILTER 27MH E-TYPE OPEN	051687-10	
L602	COIL CHOKE 50UH	053739-10	
L604	COIL 47UH J LAL03	53778	
L701	COIL- CHOKE 10UH R0814 14.1	53352	
P601	R-VAR 2.2K (V) 5*3	132209	
PLS	PE PAG 1050*1200*.05 DELIKLI	44763	
Q101	CRYSTAL 12MHZ CL=30PF/30PPM BULK	56946	
R0001	CFR 220R J 1/2W 52MM	101221	
R0002	CFR 1K J 1/4W /6 26MM	102141	
R0003	CFR 220R J 1/2W 52MM	101221	
R0004	CFR 1K J 1/4W /6 26MM	102141	
R0005	CFR 470R J 1/2W /9 52MM	101471	
R01	RC-CHIP 0R /1206	179002	
R101	RC-CHIP 3.3K J 1/16W /0603	172336	
R102	RC-CHIP 15K J 1/16W /0603 TAPE	173153	
R103	CFR 100R J 1/4W 52MM	101106	
R104	RC-CHIP 3.3K J 1/16W /0603	172336	
R106	RC-CHIP 0R /0603 1.6*0.8 TAPE	179005	
R107	RC-CHIP 3.3K J 1/16W /0603	172336	

POSITION NO	DECRPTION	PART NO	NOTES
R108	RC-CHIP 3.3K J 1/16W /0603	172336	
R109	RC-CHIP 2.2K J 1/16W/0603 TAPE	172224	
R110	RC-CHIP 1.5K J 1/16W /0603 TAPE	172154	
R111	RC-CHIP 0R /0805 2*1.25	179001	
R112	RC-CHIP 0R /0603 1.6*0.8 TAPE	179005	
R113	CFR 3.3K J 1/4W /6 52MM	102338	
R114	RC-CHIP 3.3K J 1/16W /0603	172336	
R115	RC-CHIP 3.3K J 1/16W /0603	172336	
R116	RC-CHIP 3.3K J 1/16W /0603	172336	
R117-R119	RC-CHIP 100R J 1/16W /0603	171107	
R120	RC-CHIP 330K J 1/16W /0603 TAPE	174333	
R121	RC-CHIP 100R J 1/16W /0603	171107	
R122	RC-CHIP 3.3K J 1/16W /0603	172336	
R123	RC-CHIP 0R /0603 1.6*0.8 TAPE	179005	
R124	CFR 100R J 1/4W 52MM	101106	
R125	RC-CHIP 680R J 1/16W /0603	171683	
R126	RC-CHIP 1.5K J 1/16W /0603 TAPE	172154	
R127	RC-CHIP 10K J 1/16W /0603	173108	
R128	CFR 100K 1% 1/4W 52MM	104109	
R129	RC-CHIP 150R J 1/16W /0603	171154	
R130	CFR 2.7K J 1/4W /6 26MM	142274	
R132	RC-CHIP 0R /0603 1.6*0.8 TAPE	179005	
R142	RC-CHIP 10K J 1/16W /0603	173108	
R147	RC-CHIP 1K J 1/16W /0603	172104	
R149	RC-CHIP 1K J 1/16W /0603	172104	
R157	RC-CHIP 0R /0603 1.6*0.8 TAPE	179005	
R158-R159	RC-CHIP 100R J 1/16W /0603	171107	
R160	CFR 100R J 1/4W 52MM	101106	
R161	RC-CHIP 3.9K J 1/16W/0603 TAPE	172393	
R162	CFR 680R J 1/4W /6 52MM	101683	
R163	CFR 100R J 1/4W 52MM	101106	
R164	CFR 100R J 1/4W 52MM	101106	
R165	CFR 1K J 1/4W /6 52MM	102101	
R166	CFR 100R J 1/4W 52MM	101106	
R167-R172	RC-CHIP 100R J 1/16W /0603	171107	
R173	RC-CHIP 39K J 1/16W /0603 TAPE	173394	
R174	RC-CHIP 390R %1 1/16W/0603 TAPE	171392	
R176	RC-CHIP 100K J 1/16W /0603	173114	
R177-R178	RC-CHIP 27K J 1/16W /0603 TAPE	173277	
R180	RC-CHIP 47K J 1/16W /0603 TAPE	173478	
R181	RC-CHIP 4.7R J 1/16W/0603	179475	
R184	RC-CHIP 100K J 1/16W /0603	173114	
R185	RC-CHIP 2.7K J 1/16W /0603	172276	
R187	RC-CHIP 680R J 1/16W /0603	171683	
R188	RC-CHIP 270R J 1/16W/0603 TAPE	171227	
R189	RC-CHIP 390R %1 1/16W/0603 TAPE	171392	
R190	RC-CHIP 180R J 1/16W /0603	171184	
R191	RC-CHIP 470R J 1/16W /0603 TAPE	171472	
R192	RC-CHIP 560R J 1/16W/0603 TAPE	171562	
R193	RC-CHIP 15K J 1/16W /0603 TAPE	173153	
R194-R195	RC-CHIP 100R J 1/16W /0603	171107	
R196	RC-CHIP 1K J 1/16W /0603	172104	
R201	RC-CHIP 2.2K J 1/16W/0603 TAPE	172224	
R202	RC-CHIP 100R J 1/16W /0603	171107	
R203	CFR 100R J 1/4W 52MM	101106	
R204-R209	RC-CHIP 75R J 1/16W /0603	170754	
R210-R213	RC-CHIP 15K J 1/16W /0603 TAPE	173153	
R214	RC-CHIP 75R J 1/16W /0603	170754	

POSITION NO	DECRPTION	PART NO	NOTES
R215-R216	RC-CHIP 180R J 1/16W /0603	171184	
R217-R222	RC-CHIP 1K J 1/16W /0603	172104	
R224	RC-CHIP 3.9K J 1/16W/0603 TAPE	172393	
R225	JUMPER WIRE D=.6	 500700-KD	
R226	RC-CHIP 5.6K J 1/16W /0603 TAPE	172567	
R228	RC-CHIP 68K J 1/16W /0603	173685	
R229	RC-CHIP 68K J 1/16W /0603	173685	
R231	RC-CHIP 470R J 1/16W /0603 TAPE	171472	
R233	RC-CHIP 4.7K J 1/16W /0603 TAPE	172479	
R234	RC-CHIP 4.7K J 1/16W /0603 TAPE	172479	
R235	RC-CHIP 4.7K J 1/16W /0603 TAPE	172479	
R236	CFR 47R J 1/4W /6 52MM	100473	
R238-R240	CFR 100R J 1/4W 52MM	101106	
R250	RC-CHIP 0R /0603 1.6*0.8 TAPE	179005	
R301	RC-CHIP 15K J 1/16W /0603 TAPE	173153	
R302	RC-CHIP 1.8K J 1/16W /0603	172182	
R303	RC-CHIP 15K J 1/16W /0603 TAPE	173153	
R304	RC-CHIP 4.7R J 1/16W/0603	179475	
R305	RC-CHIP 4.7R J 1/16W/0603	179475	
R306	RMF 4.7R J 1.5W	119485	
R308	RC-CHIP 1M J 1/16W/0603 T&R	175105	
R501	CFR 22R J 1/4W	100228	
R504	RC-CHIP 47K J 1/16W /0603 TAPE	173478	
R505	RMF 0.22R J 1W	119224	
R506	RC-CHIP 270R J 1/16W/0603 TAPE	171227	
R507	RC-CHIP 470R J 1/16W /0603 TAPE	171472	
R509	RC-CHIP 220K J 1/16W /0603 TAPE	174224	
R510	RC-CHIP 390K J 1/10W /0805	174391	
R511	RC-CHIP 5.6K J 1/16W /0603 TAPE	172567	
R511	RC-CHIP 5.6K J 1/16W /0603 TAPE	172567	
R512	CFR 560R J 1/4W /6 52MM	101562	
R513	CFR 0.47R J 1/2W /9 52MM	109472	
R514	CFR 47R J 1/4W /6 52MM	100473	
R515	RC-CHIP 2.2K %1 1/10W /0805	172227	
R516	RC-CHIP 2.2K %1 1/10W /0805	172227	
R517	RC-CHIP 10K J 1/10W /0805	173101	
R518	RC-CHIP 2.7K J 1/16W /0603	 172276	
R520	RM 1.8R J 1/2W 52MM	119185	
R521	CFR 330R J 1/4W /6 26MM	101343	
R522	CFR 1.5R J 1/2W /9	109150	
R523-R524	RM 150K F 1/4W 52MM	114152	
R526	RMO 2.2R J 2W R:27.5 TAPE	119236	
R528	RM 22K J 1/2W 52MM	113225	
R529	CFR 470R J 1/2W /9 52MM	101471	
R530	CFR 1K J 1/4W /6 52MM	102101	
R531	CFR 10R J 1/4W 52MM	100107	
R532	RC-CHIP 220R J 1/16W/0603 TAPE	171224	
R533	RC-CHIP 270R J 1/16W/0603 TAPE	171227	
R537-R538	RC-CHIP 10K J 1/16W /0603	173108	
R603	RC-CHIP 8.2K J 1/16W /0603 TAPE	172824	
R604	PTC 9R/2 PIN - 3 CYCLE BOX TYPE	154234	
R605	RW 2.7R K 5W R:15 MM	129272	
R608	RMO 68K J 1.5W 73MM	113683	
R609	CFR 22K J 1/4W 52MM	103224	
R610	CFR 22K J 1/4W 52MM	103224	
R611	RC-CHIP 0R /0603 1.6*0.8 TAPE	179005	
R613	RC-CHIP 33K J 1/16W /0603 TAPE	173332	
R614	CFR 470K J 1/2W /9 52MM	104471	

POSITION NO	DECRPTION	PART NO	NOTES
R615	RC-CHIP 0R /0603 1.6*0.8 TAPE	179005	
R616	RM 1M J 1W 52MM	115103	
R617	RM 3.9M J 1W 52MM	115391	
R618	RC-CHIP 39K J 1/16W /0603 TAPE	173394	
R619	CFR 15K J 1/4W 52MM	103155	
R621	CFR 47R J 1/4W /6 52MM	100473	
R622	RM 4.7M J 1/2W 52MM 'SAFETY '	115470	
R623	RNF 0.1R J 0.4W (UFLB) 52MM	119109	
R629	RC-CHIP 0R /0603 1.6*0.8 TAPE	179005	
R701-R702	RMO 15K J 1W R:15	113153	
R703	RMO 15K J 1W R:15	113153	
R704	RC-CHIP 100R J 1/16W /0603	171107	
R705-R708	RC-CHIP 220R J 1/16W/0603 TAPE	171224	
R709-R111	RC-CHIP 390R %1 1/16W/0603 TAPE	171392	
R712-R713	RC-CHIP 22R J 1/10W /0603	170225	
R714	RC-CHIP 22R J 1/10W /0603	170225	
R715	CFR 2.7K J 1/4W /3.2 52MM	142272	
R716	CFR 2.7K J 1/4W /3.2 52MM	142272	
R717-R719	RC-CHIP 1K J 1/16W /0603	172104	
R720-R722	CFR 1.5K J 1/2W /9 52MM	102159	
R723	CFR 220R J 1/4W /3.2 26MM	141222	
R724	RC-CHIP 220R J 1/16W/0603 TAPE	171224	
R725	RC-CHIP 2.7K J 1/16W /0603	172276	
R726	CFR 100K J 1/2W 52MM	104103	
SK201	SCART SOCKET 12.6/12.7	31244	
SW601	ON/OFF SWITCH BK98	10861	
T01	TRN BC337-25	401047	
T02	TRN-CHIP BC858B SOT23	401142	
T102	TRN-CHIP BC848B SOT23	401141	
T108-T109	TRN-CHIP BC848B SOT23	401141	
T201-T203	TRN-CHIP BC848B SOT23	401141	
T301	TRN-CHIP BC848B SOT23	401141	
T503-T505	TRN BC639	400240	
T507	TRN-CHIP BC858B SOT23	401142	
T701-T703	TRN 2SC 2482	401397	
T704-T706	TRN BF421	401366	
TU101	TUNER PH ASM.PLL UV1316/AIG-4 (SHORT	G99136-PH3	
TUNMAS	CABLE SINGLE ISO. L=400 YELLOW	500542-AS	
X0001	KONN.KABLO 4'LU FERRITLI L=350MM	Z50500-AS	
X0002	KONN. CINCH YELLOW HOR.14.1	31165	
X0003	KONN. CINCH WHITE HOR.14.1	31163	
X0005	EARPHONE JACK	31791	
X0006	CABLE HOLDER 3P	500296	
X0006	CONN.KABLO 3'LU FERRITLI L=310MM	Z50504-AS	
X0007	CABLE HARNESS DBIS 2P L=900 1*7*.2 T01/T	H20524-AS	
X101	PIN HEADER 2.5MM 6'LI JST SB(6)P-HVQ-B	31768	
X104	CABLE WITH HOLDER 6P L=410 CRT/CHASI 12.	M98550-AS	
X201	CONN.HOUSING X2004 BLACK	31860	
X301	CONN.HOUSING X2003 BLACK	31856	
X501	CONN.HOUSING 2'LI GREY	31850	
X502	CON.HOUSING LOCKED 5/4	31777	
X601	CON.HOUSING 2P MALE TPK75(POW)12.6 SHORT	31793	
X602	CON.HOUSING 2P MALE TPK75(POW)12.6 RED	31797	
X702	CRT SOCKET NARROW INCHANG	31532	
ZD101	DIODE Z. ZPD5.1V 26MM	302298	
ZD102	DIODE Z. BZX55C3V3	303110	
ZD501	DIODE Z. BZX55C 15V	303826	
ZD502	DIODE Z. C8V2 26MM	302294	

POSITION NO	DECRPTION	PART NO	NOTES
ZD503	DIODE Z.TZMC5V6-5.6V SOD80C	303864	
ZD601	DIODE Z. BZX55C33 52MM	302318	
ZD701	DIODE Z. C8V2 26MM	302294	
	CPT VC A51EFS13X191	056321-VC6	
	DEGAUSSING COIL HOLDER FASON	△ 871273	
	DEGAUSSING COIL HOLDER	△ A99273	
	DEGAUSSING COIL ASSY 21" BAND	△ 621167-AS	
	FLUX RF 800NO CLEAN	60163	
	SOLVENT KR-IN 2613	060155-01	
TR501	FBT 20/21" E1	△ 040146-EL1	Alternative 040146-TR1
TR601	SMPS 20/21" E1	△ 050146-EL1	Alternative 050146-TR1

