

Low Quiescent Current_Low Dropout

MD75XXH Series

High Input CMOS Voltage Regulator

120mA

The MD75XXH series is a family of Low Dropout Positive regulators. developed using CMOS technology. These IC products perform with high output voltage accuracy, low quiescent current , Output current 120mA, at the same time with high input voltage capacity it can be up to 24V, suitable for applications which requires higher voltage circuit.

■ Ferture(Typical):

- high output voltage accuracy $\pm 3\%$
- low dropout voltage 5.0mV
- low quiescent current 1.6uA
- low output voltage temperature drift 50 PPM / $^{\circ}\text{C}$
- high input voltage up to 24V keeping stable output voltage
- Output short circuit protection Short-circuit current less than 100 mA

■ Applications

- battery-powered devices
- mobile phone devices
- communications equipments
- home electric/toy appliances
- portable medical equipments

■ Selection table

Part NO.	Output voltage (Note)	Tolerance
MD7530	3.0V	$\pm 3\%$
MD7533	3.3V	$\pm 3\%$
MD7536	3.6V	$\pm 3\%$
MD7540	4.0V	$\pm 3\%$
MD7544	4.4V	$\pm 3\%$
MD7550	5.0V	$\pm 3\%$

NOTE: for semi_custom parts selectable output voltage from 1.5~7.0V in 0.1v Increment.

■ Package and Pin Assignment



■ Absolute Maximum Ratings: (Ta=25°C unless otherwise specified)

Item	Symbol	Absolute Maximum Ratings	Unit
Input voltage	V _{IN}	24	V
Output voltage	V _{OUT}	V _{SS} -0.3 ~ V _{IN} +0.3	
Power dissipation	P _D	SOT_89 500 TO_92 300	mW
Operation temperature range	T _{opr}	-40~+85	°C
Storage temperature range	T _{stg}	-40~+125	

Note: The absolute maximum ratings are rated values exceeding which the product could suffer physical damage. These values must therefore not be exceeded under any conditions.

■ Electrical Characteristics:

MD75XXH series (MD7530H, Output voltage +3.0V) (Ta=25°C unless otherwise specified)

ITEM	SYMBOL	CONDITIONS	MIN	TYPE	MAX	UNITS	Test circuits
Output voltage	V _{OUT}	V _{IN} = 5V, I _{OUT} =10mA	2.91	3.0	3.09	V	1
Output current *1	I _{OUT}	V _{IN} = 5V			120	mA	3
Dropout voltage *2	V _{drop}	I _{OUT} =1 mA I _{OUT} =10 mA		5 50		mV	1
Line regulation	$\frac{\Delta V_{OUT1}}{\Delta V_{IN} \cdot V_{OUT}}$	4V ≤ V _{IN} ≤ 24V I _{OUT} =1mA		0.05	0.2	%/V	
Load regulation	ΔV_{OUT2}	V _{IN} =5V 1.0mA ≤ I _{OUT} ≤ 100mA		60	100	mV	
Temperature coefficient	$\frac{\Delta V_{OUT}}{\Delta T_a \cdot V_{OUT}}$	V _{IN} =5V, I _{OUT} =10mA -40°C ≤ T _a ≤ 85°C		± 50	± 100	ppm/ °C	
Current consumption	I _{SS1}	V _{IN} =24V 无负载		1.2	2.5	uA	2
Input voltage	V _{IN}	--		3.0	24	V	
Short current limit	I _{lim}	V _{out} =0V			100		

MD75XXH series(MD7533H, Output voltage +3.3V) (Ta=25°C unless otherwise specified)

ITEM	SYMBOL	CONDITIONS	MIN	TYPE	MAX	UNITS	Test circuits
Output voltage	V _{OUT}	V _{IN} = 5.3V, I _{OUT} =10mA	3.201	3.3	3.399	V	1
Output current *1	I _{OUT}	V _{IN} = 5.3V			120	mA	3
Dropout voltage *2	V _{drop}	I _{OUT} =1 mA I _{OUT} =10 mA		5 45		mV	1
Line regulation	$\frac{\Delta V_{OUT1}}{\Delta V_{IN} \cdot V_{OUT}}$	4.3V ≤ V _{IN} ≤ 24V I _{OUT} =1mA		0.05	0.2	%/V	
Load regulation	ΔV _{OUT2}	V _{IN} =5.3V 1.0mA ≤ I _{OUT} ≤ 100mA		60	100	mV	
Temperature coefficient	$\frac{\Delta V_{OUT}}{\Delta T_a \cdot V_{OUT}}$	V _{IN} =5.3V, I _{OUT} =10mA -40°C ≤ T _a ≤ 85°C		± 50	± 100	ppm/ °C	
Current consumption	I _{SS1}	V _{IN} =24V 无负载		1.2	2.5	uA	2
Input voltage	V _{IN}	--			24	V	
Short current limit	I _{lim}	V _{out} =0V			100	mA	

MD75XXH series(MD7536H, Output voltage +3.6V) (Ta=25°C unless otherwise specified)

ITEM	SYMBOL	CONDITIONS	MIN	TYPE	MAX	UNITS	Test circuits
Output voltage	V _{OUT}	V _{IN} = 5.6V, I _{OUT} =10mA	3.492	3.6	3.708	V	1
Output current *1	I _{OUT}	V _{IN} = 5.6V			120	mA	3
Dropout voltage *2	V _{drop}	I _{OUT} =1 mA I _{OUT} =10mA		5 40		mV	1
Line regulation	$\frac{\Delta V_{OUT1}}{\Delta V_{IN} \cdot V_{OUT}}$	4.6V ≤ V _{IN} ≤ 24V I _{OUT} =1mA		0.05	0.2	%/V	
Load regulation	ΔV _{OUT2}	V _{IN} =5.6V 1.0mA ≤ I _{OUT} ≤ 100mA		60	100	mV	
Temperature coefficient	$\frac{\Delta V_{OUT}}{\Delta T_a \cdot V_{OUT}}$	V _{IN} =5.6V, I _{OUT} =10mA -40°C ≤ T _a ≤ 85°C		± 50	± 100	ppm/ °C	
Current consumption	I _{SS1}	V _{IN} =24V 无负载		1.2	2.5	uA	2
Input voltage	V _{IN}	--			24	V	
Short current limit	I _{lim}	V _{out} =0V			100	mA	

MD75XXH series(MD7540H, Output voltage +4.0V) (Ta=25°C unless otherwise specified)

ITEM	SYMBOL	CONDITIONS	MIN	TYPE	MAX	UNITS	Test circuits
Output voltage	V _{OUT}	V _{IN} = 6.0V, I _{OUT} =10mA	3.880	4.0	4.120	V	1
Output current *1	I _{OUT}	V _{IN} = 6.0V			120	mA	3
Dropout voltage *2	V _{drop}	I _{OUT} =1 mA I _{OUT} =10 mA		5 35		mV	1
Line regulation	$\frac{\Delta V_{OUT1}}{\Delta V_{IN} \cdot V_{OUT}}$	5.4V ≤ V _{IN} ≤ 24V I _{OUT} =1mA		0.05	0.2	%/V	
Load regulation	ΔV _{OUT2}	V _{IN} =6.0V 1.0mA ≤ I _{OUT} ≤ 100mA		60	100	mV	
Temperature coefficient	$\frac{\Delta V_{OUT}}{\Delta T_a \cdot V_{OUT}}$	V _{IN} =6.0V, I _{OUT} =10mA -40°C ≤ T _a ≤ 85°C		± 50	± 100	ppm/ °C	
Current consumption	I _{SS1}	V _{IN} =24V 无负载		1.2	2.5	uA	2
Input voltage	V _{IN}	--			24	V	
Short current limit	I _{lim}	V _{out} =0V			100	mA	

MD75XXH series(MD7544H, Output voltage +4.4V) (Ta=25°C unless otherwise specified)

ITEM	SYMBOL	CONDITIONS	MIN	TYPE	MAX	UNITS	Test circuits
Output voltage	V _{OUT}	V _{IN} = 6.4V, I _{OUT} =10mA	4.268	4.4	4.532	V	1
Output current *1	I _{OUT}	V _{IN} = 6.4V			120	mA	3
Dropout voltage *2	V _{drop}	I _{OUT} =1 mA I _{OUT} =10 mA		5 35		mV	1
Line regulation	$\frac{\Delta V_{OUT1}}{\Delta V_{IN} \cdot V_{OUT}}$	5.4V ≤ V _{IN} ≤ 24V I _{OUT} =1mA		0.05	0.2	%/V	
Load regulation	ΔV _{OUT2}	V _{IN} =6.4V 1.0mA ≤ I _{OUT} ≤ 100mA		60	100	mV	
Temperature coefficient	$\frac{\Delta V_{OUT}}{\Delta T_a \cdot V_{OUT}}$	V _{IN} =6.4V, I _{OUT} =10mA -40°C ≤ T _a ≤ 85°C		± 50	± 100	ppm/ °C	
Current consumption	I _{SS1}	V _{IN} =24V 无负载		1.2	2.5	uA	2
Input voltage	V _{IN}	--			24	V	
Short current limit	I _{lim}	V _{out} =0V			100	mA	

MD75XXH series(MD7550H, Output voltage +5.0V) (Ta=25°C unless otherwise specified)

ITEM	SYMBOL	CONDITIONS	MIN	TYPE	MAX	UNITS	Test circuits
Output voltage	V _{OUT}	V _{IN} = 7V, I _{OUT} =10mA	4.85	5.0	5.15	V	1
Output current *1	I _{OUT}	V _{IN} = 7V			120	mA	3
Dropout voltage *2	V _{drop}	I _{OUT} =1 mA I _{OUT} =10 mA		5 30		mV	1
Line regulation	$\frac{\Delta V_{OUT1}}{\Delta V_{IN} \cdot V_{OUT}}$	6V ≤ V _{IN} ≤ 24V I _{OUT} =1mA		0.05	0.2	%/V	
Load regulation	ΔV _{OUT2}	V _{IN} =7V 1.0mA ≤ I _{OUT} ≤ 100mA		60	100	mV	
Temperature coefficient	$\frac{\Delta V_{OUT}}{\Delta T_a \cdot V_{OUT}}$	V _{IN} =7V, I _{OUT} =10mA -40°C ≤ T _a ≤ 85°C		± 50	± 100	ppm/ °C	
Current consumption	I _{SS1}	V _{IN} =24V 无负载		1.2	2.5	uA	2
Input voltage	V _{IN}	--			24	V	
Short current limit	I _{lim}	V _{out} =0V			100	mA	

* 1. Increasing output current slowly, The I_{OUT} when output voltage decreasing two percent

* 2. $V_{drop} = V_{IN1} - (V_{OUT(E)} \times 0.98V)$

V_{OUT(E)} Effective output voltage, i.e., the output voltage when fixing I_{OUT}(=1mA) and inputting V_{OUT(S)}+2.0 V.

V_{IN1}: is the Input voltage at which output voltage becomes 98 percent of V_{OUT(E)} after gradually decreasing input voltage.

■ Test Circuits

1.

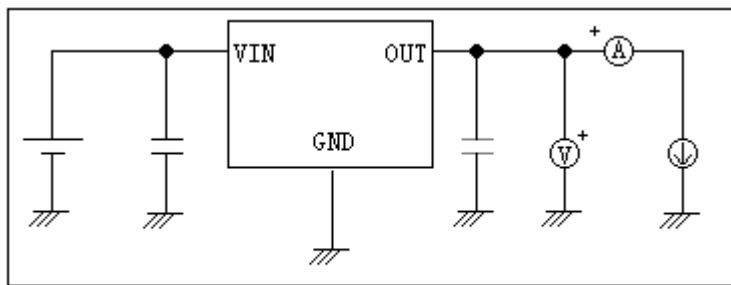

Circuit 1

2.

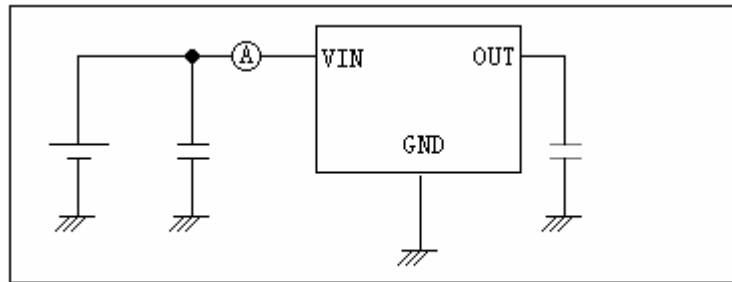

Circuit 2

3.

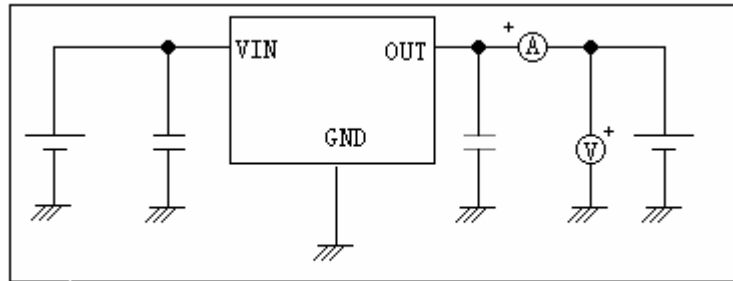

Circuit 3

■Standard Circuit:

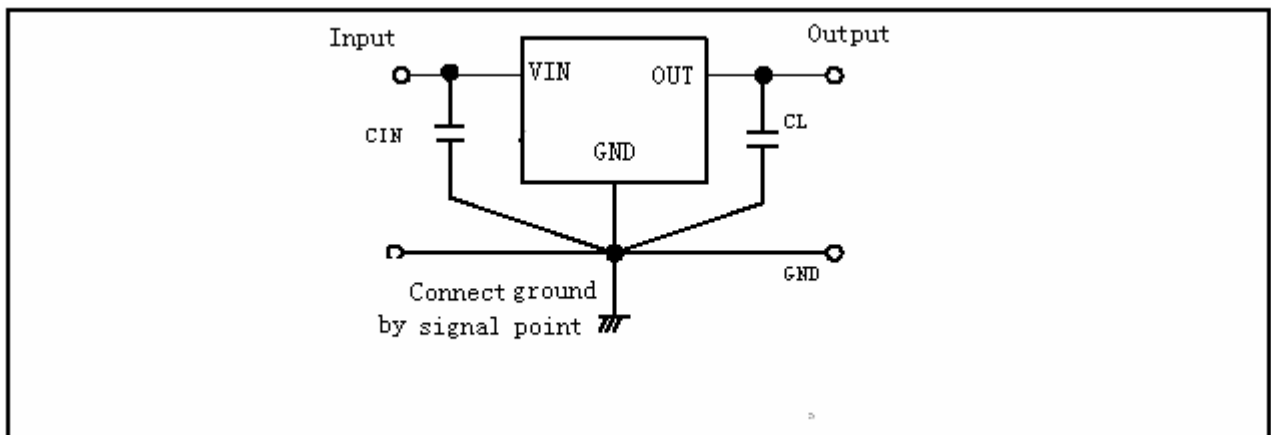

Note: The above connection diagram and constant will not guarantee successful operation. Perform through evaluation using the actual application to set the constant.

■using conditions:

Input capacitors(C_{IN}): $>1.0 \mu\text{F}$.

Output capacitors(C_L): $>2.2 \mu\text{F}$ (tantalum capacitors).

*1. C_{IN} is a capacitor for stabilizing the input.

*2. A ceramic capacitor can be used for C_L besides a tantalum capacitor.

* Note: In general, linear regulated power supply may lead to oscillation by choosing the

different external components. Please make sure the capacitor before used in the application circuit does not oscillate.

■ Technical Terms

1. Output capacitors (C_L)

Output capacitors are generally used to stabilize regulation operation and to improve transient response characteristics. But the MD75XXH series can provide stable operation without output capacitors. Capacitors are used only to improve transient response characteristics. Output capacitors can hence be removed in applications in which transient response can be negligible. When an output capacitor is used, a low ESR (Equivalent Series Resistance) capacitor like ceramic capacitor can also be used.

2. Output voltage (V_{out})

The accuracy of the output voltage is $\pm 3.0\%$ guaranteed under the specified conditions for input voltage, which differs depending upon the product items, output current, and temperature.

Caution: If the above conditions change, the output voltage value may vary and go out of the accuracy range of the output voltage. See the electrical characteristics and characteristics data for details.

3. Line regulations ($\Delta V_{OUT1} / \Delta V_{IN} * V_{OUT}$)

These parameters indicate the input voltage dependence on the output voltage. That is, the values show how much the output voltage changes due to a change in the input voltage with the output current remained unchanged.

4. Load regulation (ΔV_{OUT2})

This parameter indicates the output current dependence on the output voltage. That is, the value shows how much the output voltage changes due to a change in the output current with the input voltage remained unchanged.

5. Dropout voltage (V_{drop})

This parameter indicates the difference between the input voltage (V_{IN1}) and the output voltage when

output voltage falls to 98 % of $V_{OUT(E)}$ by gradually decreasing the input voltage (V_{IN}).

$$V_{drop} = V_{IN1} - [V_{OUT(E)} \times 0.98]$$

■ Description of Operation

1. Basic Operation

Figure 8 shows the block diagram of the MD75XXH series. The error amplifier compares a reference voltage V_{ref} with a part of the output voltage divided by the feedback resistors R_s and R_f , and supplies the gate voltage to the output transistor, necessary to ensure certain output voltage independent from change of input voltage and temperature.

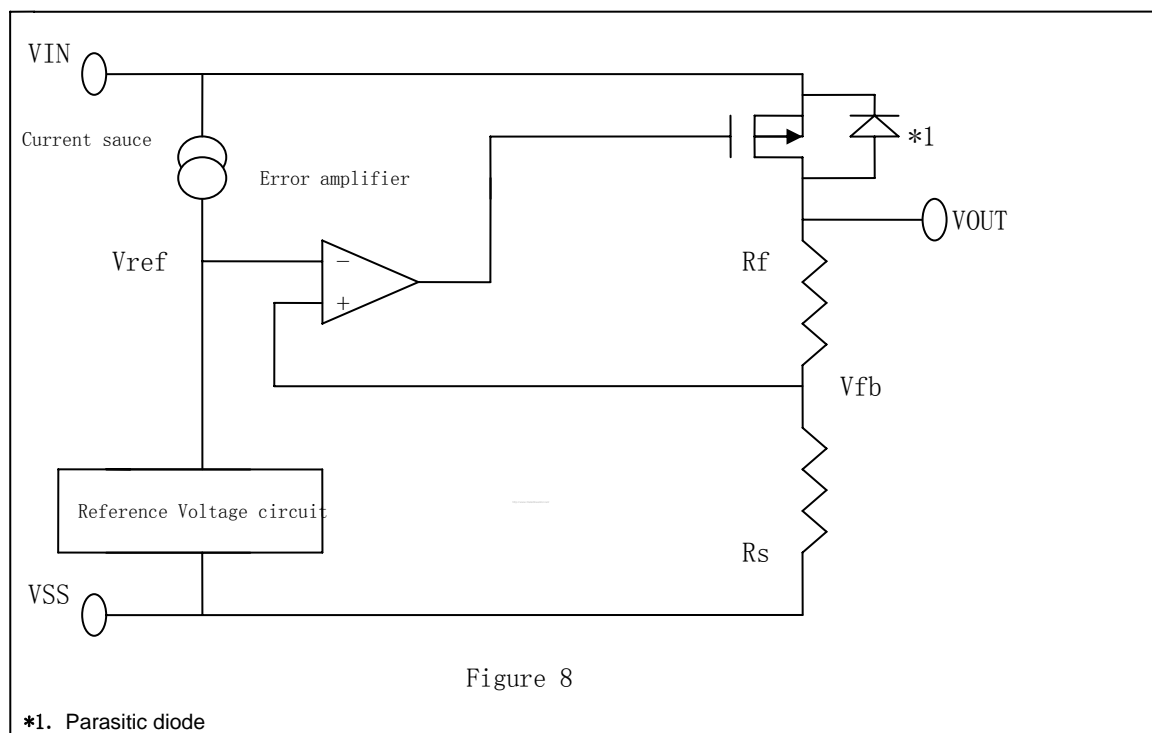

2. Output Transistor

The MD75XXH Series uses a Pch MOS FET as the output transistor.

The voltage at V_{OUT} must not exceed $V_{IN} + 0.3V$. When the V_{OUT} voltage becomes higher than that of V_{IN} , reverse current flows and may break the regulator since a parasitic diode between V_{OUT} and V_{IN} exists inevitably

3. Short-circuit protection

Installation of the short-circuit protection which protects the output transistor against short-circuit between V_{OUT} and V_{SS} can be selected in the MD75XXH series. The short-circuit protection controls output current as shown in the typical characteristics, (1) OUTPUT VOLTAGE versus OUTPUT CURRENT, and suppresses output current at about 40 mA even if V_{OUT} and V_{SS} pins are short-circuited.

The short-circuit protection can not at the same time be a thermal protection. Attention

should be paid to the Input voltage and the load current under the actual condition so as not to exceed the power dissipation of the package including the case for short-circuit.

When the output current is large and the difference between input and output voltage is large even if not shorted, the short-circuit protection may work and the output current is suppressed to the specified value. Products without short-circuit protection can provide comparatively large current by removing a short-circuit protection.

■ Selection of External Components

Output Capacitor (C_L)

The MD75XXH series can provide stable operation without output capacitor (C_L) since the regulator has an internal phase compensation circuit to stabilize operation when the load changes. The transient response of the regulator, however, changes with the output capacitor and the magnitude of overshoot and undershoot on output voltage accordingly changes. Please refer to C_L dependence data in “Transient Response Characteristics” to select suitable value for the capacitor.

When a tantalum or an aluminum electrolytic capacitor is used, the ESR of the capacitor shall be $10\ \Omega$ or less. When an aluminum electrolytic capacitor is used attention should be especially paid to since the ESR of the aluminum electrolytic capacitor increases at low temperature and possibility of oscillation becomes large. Sufficient evaluation including temperature characteristics is indispensable.

■ Precautions:

- Design wiring patterns for VIN, VOUT and GND pins to hold low impedance.

When mounting an output capacitor between the VOUT and VSS pins (C_L) and a capacitor for stabilizing the input between VIN and VSS pins (C_{IN}), the distance from the capacitor to the VOUT pin and to the VSS pin should be as short as possible.

- Note that output voltage may be increased at low load current of less than 1 μ A.
- To prevent oscillation, it is recommended to use the external parts under the following conditions.

Equivalent Series Resistance (ESR): $30\ \Omega$ or less

Input series resistance (R_{IN}): $10\ \Omega$ or less

- A voltage regulator may oscillate when power source impedance is high and input capacitor is low or not connected.
- The application condition for input voltage and load current should not exceed the package power dissipation.
- Pay attention to the operating conditions for input/output voltage and load current so that the power loss in the IC does not exceed the power dissipation of the package.
- Do not apply an electrostatic discharge to this IC that exceeds the performance

ratings of the built-in electrostatic protection circuit.

- SII claims no responsibility for any and all disputes arising out of or in connection with any infringement of the products including this IC upon patents owned by a third party.

Application Circuits

Basic Circuits

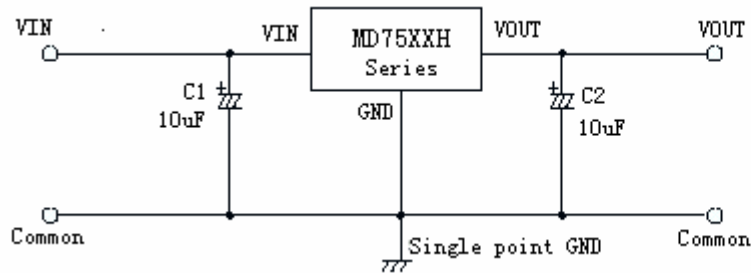

High Output Current Positive Voltage Regulator

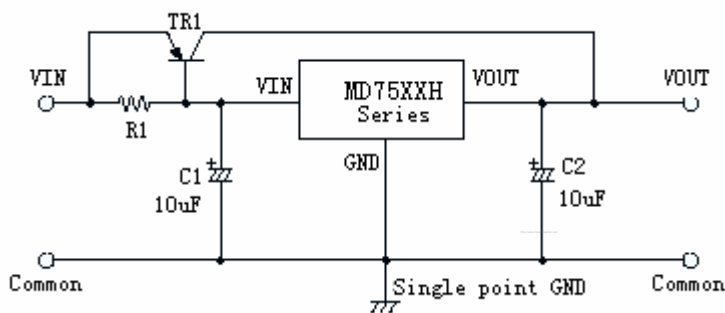

Short-Circuit Protection by Tr1

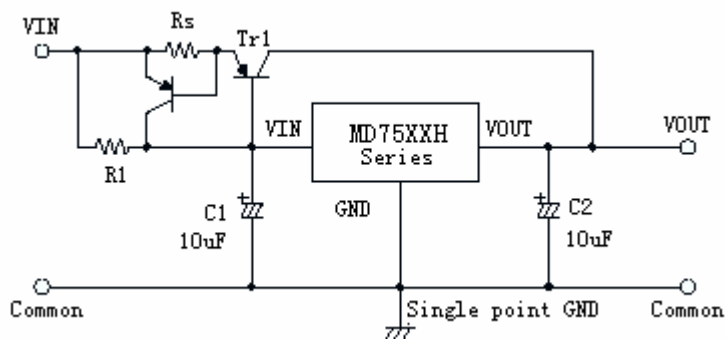

Circuit for Increasing Output Voltage

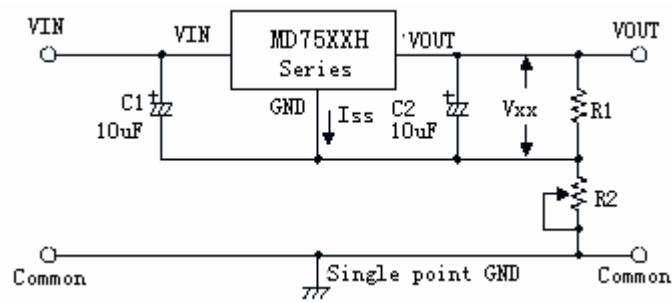

$$V_{OUT} = V_{xx} (1 + R2/R1) + I_{SS} * R2$$

Constant Current Regulator

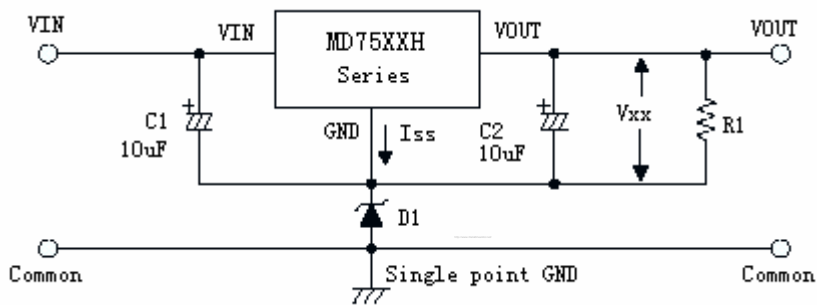

$$V_{OUT} = V_{xx} + V_{D1}$$

Dual Supply

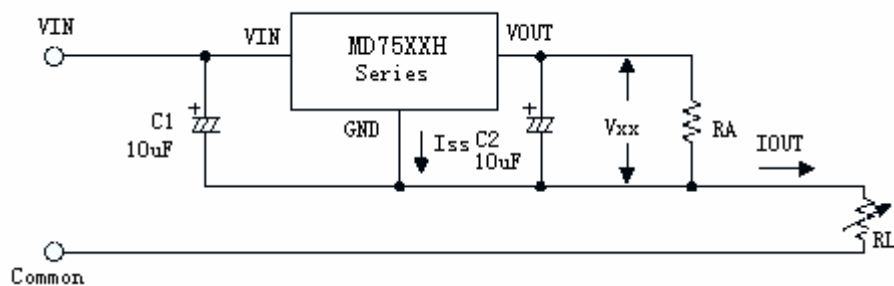

$$I_{OUT} = V_{xx} / R_A + I_{SS}$$