

Quad Low Power Operational Amplifiers

The PJ324 series are low-cost, quad operational amplifiers with true differential inputs. These have several distinct advantages over standard operational amplifier types in single supply applications. The quad amplifiers can operate at supply voltages as low as 3.0V or as high as 32V with very low

quiescent currents and eliminate the necessity for external biasing components in many applications. The output voltage range also includes the negative power supply voltage.

FEATURES

- Short circuited protected outputs
- True differential input stage
- Single supply operation: 3.0V to 32V
- Low input bias currents: 100nA Max
- Four amplifiers per package
- Internally compensated
- Common mode range extends to negative supply
- Industry standard pinouts
- ESD clamps on the inputs increase ruggedness without affecting device operation

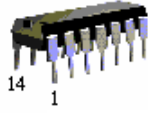
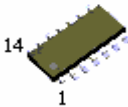
DIP-14	SOP-14
	
Pin:	
1. Output 1	8. Output 3
2. Input 1 (-)	9. Input 3 (-)
3. Input 1 (+)	10. Input 3 (+)
4. Vcc	11. Vee Gnd
5. Input 2 (+)	12. Input 4 (+)
6. Input 2 (-)	13. Input 4 (-)
7. Output 2	14. Output 4

ORDERING INFORMATION

Device	Operating Temperature	Package
PJ324CD	-20°C to +85°C	DIP-14
PJ324CS		SOP-14

MAXIMUM RATING (Ta = +25°C, unless otherwise noted.)

Rating	Symbol	PJ324	Unit
Power Supply Voltage Single Supply Split Supplies	V _{CC} V _{CC} , V _{EE}	±16	Vdc
Input Differential Voltage Range (1)	V _{IDR}	32	Vdc
Input Common Mode Voltage Range	V _{ICR}	-0.3 to 32	Vdc
Output Short Circuit Duration	t _{SC}	Continuous	
Junction Temperature Plastic Packages	T _J	150	°C
Storage Temperature Ceramic Package Plastic Packages	T _{stg}	- 65 to + 150	°C

NOTE : 1. Split Power Supplies.

Quad Low Power Operational Amplifiers

ELECTRICAL CHARACTERISTICS (V_{CC}= 5.0V, V_{EE}=GND, T_A= 25 °C unless otherwise noted.)

Characteristics	Symbol	PJ324			Unit
		Min	Typ	Max	
Input Offset Voltage V _{CC} =5.0V to 30V V _{ICR} =0 V to V _{CC} -0.7V, V _O =1.4V, R _S =0Ω T _A =25°C T _A =T _{high} to T _{low} (Note 1)	V _{IO}	- -	2.0 -	7.0 9.0	mV
Average Temperature Coefficient of Input Offset Voltage T _A =T _{high} to T _{low} (Note 1)	ΔV _{IO} / ΔT	-	7.0	-	μ V / °C
Input Offset Current T _A =T _{high} to T _{low} (Note 1)	I _{IO}	- -	5.0 -	50 150	nA
Average Temperature Coefficient of Input Offset Current T _A =T _{high} to T _{low} (Note 1)	ΔI _{IO} / ΔT	-	10	-	pA / °C
Input Bias Current T _A =T _{high} to T _{low} (Note 1)	I _{IB}	- -	-90 -	-250 -500	nA
Input Common Mode Voltage Range (Note 2) V _{CC} =30V V _{CC} =30V, T _A =T _{high} to T _{low}	V _{ICR}	0 0	- -	28.3 28	V
Differential Input Voltage Range	V _{IDR}	-	-	V _{CC}	V
Large Signal Open-Loop Voltage Gain R _L =2.0K , V _{CC} =15V, for Large V _O Swing T _A =T _{high} to T _{low} (Note 1)	A _{VOL}	25 15	100 -	- -	V/mV
Channel Separation 10KHz ≤ f ≤ 20KHz, Input Referenced	CS	-	-120	-	dB
Common Mode Rejection R _S ≤ 10K Ω	CMR	65	70	-	dB
Power Supply Rejection	PSR	65	100	-	dB
Output Voltage - High Limit (T _A =T _{high} to T _{low}) (Note 1) V _{CC} =5.0V, R _L =10K , T _A =25°C V _{CC} =30V, R _L =2.0K V _{CC} =30V, R _L =10K	V _{OH}	3.3 26 27	3.5 - 28	- - -	V
Output Voltage-Low Limit V _{CC} =5.0V, R _L =10K , T _A =T _{high} to T _{low} (Note 1)	V _{OL}	-	5.0	20	mV
Output Source Current (V _{ID} =+1.0V, V _{CC} =15V) T _A =25°C T _A =T _{high} to T _{low} (Note 1)	I _O ⁺	20 10	40 20	- -	mA
Output Sink Current (V _{ID} = -1.0V, V _{CC} =15V) T _A =25°C T _A =T _{high} to T _{low} (Note 1) (V _{ID} = -1.0V, V _{CC} =200mV, T _A =25°C)	I _O ⁻	10 5.0 12	20 8.0 50	- - -	mA μ A
Output Short Circuit Ground (Note 2)	I _{sc}	-	40	60	mA
Power Supply Current (T _A =T _{high} to T _{low}) (Note 1) V _{CC} =30V (26V for LM2902), V _O =0V, R _L =∞ V _{CC} =5.0V, V _O =0V, R _L =∞	I _{cc}	- -	- -	3.0 1.2	mA

Note: 1. Short circuits from the output to V_{cc} can cause excessive heating and eventual destruction . Destructive dissipation can result from simultaneous shorts on all amplifiers.

2. The input common mode voltage or either input signal voltage should not be allowed to go negative by more than 0.3V The upper end of the common mode voltage range is V_{cc}-1.7V.

Quad Low Power Operational Amplifiers

Representative Circuit Schematic
(One-Fourth of Circuit Shown)

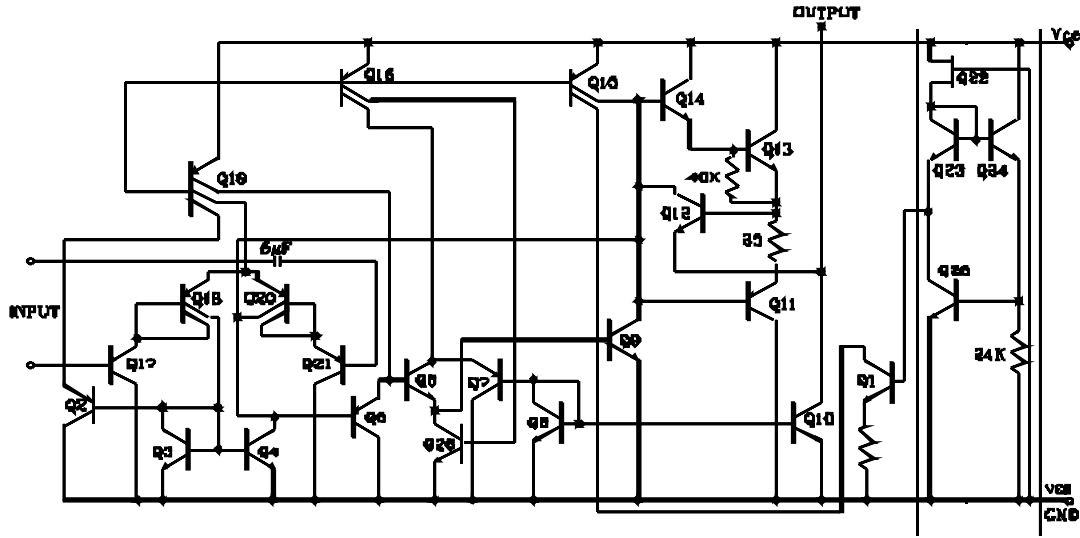

CIRCUIT DESCRIPTION

The PJ324 series is made using four internally compensated, two-stage operational amplifiers. The first stage of each consists of differential input devices Q20 and Q18 with input buffer transistors Q21 and Q17 and the differential to single ended converter Q13 and Q14. The first stage performs not only the first stage gain function but also performs the level shifting and transconductance reduction functions. By reducing the transconductance a smaller compensation capacitor (only 5.0pF) can be employed, thus saving chip area. The transconductance reduction is accomplished by splitting the collectors of Q20 and Q18. Another feature of this input stage is that the input common mode range can include the negative supply or ground, in single supply operation without saturating either the input devices or the differential to single-ended converter. The second stage consists of a standed current source load amplifier stage.

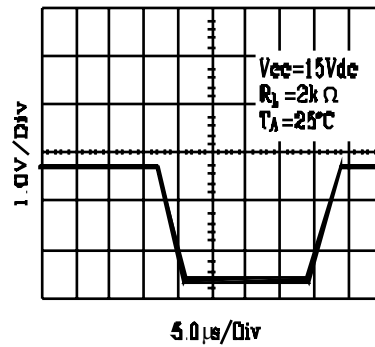

Large Signal Voltage Follower Response
Each amplifier is biased from an internal voltage regulator which has a low temperature coefficient thus giving each amplifier good temperature characteristics as well as excellent power supply rejection.

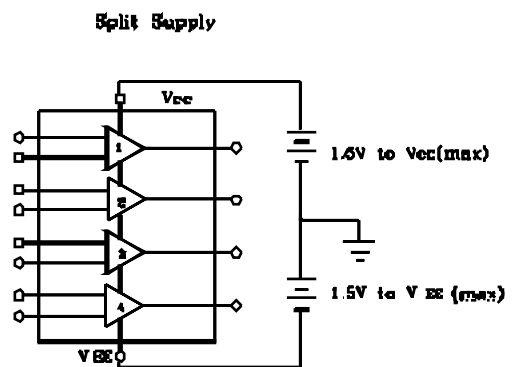
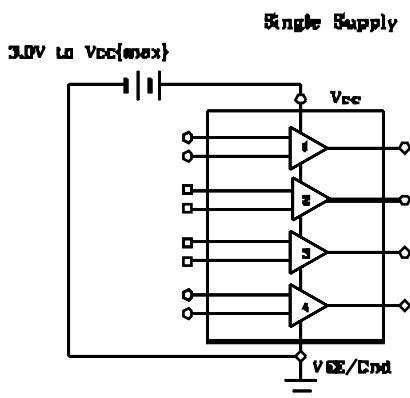

Quad Low Power Operational Amplifiers

Figure 1. Input Voltage Range

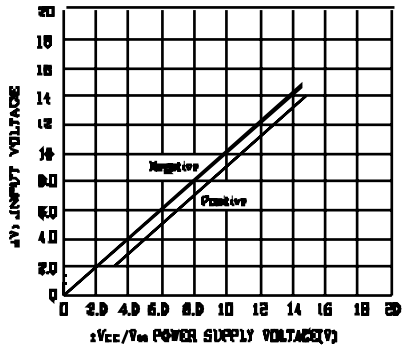

Figure 2. Open-Loop Frequency

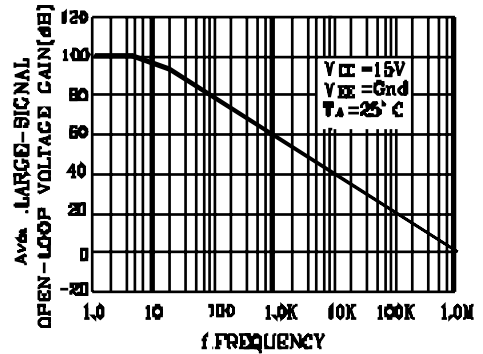

Figure 3. Large-Signal Frequency Response

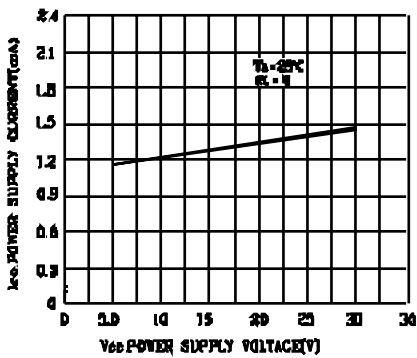

Figure 4. Small-Signal Voltage Follower Pulse Response (Noninverting)

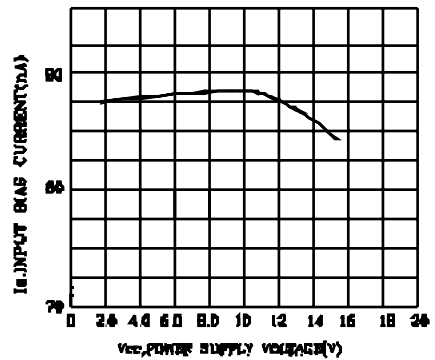

Figure 5. Power Supply Current versus Power Supply Voltage

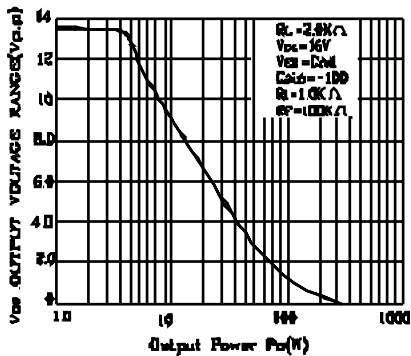
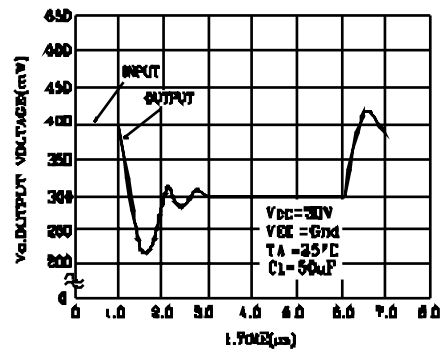
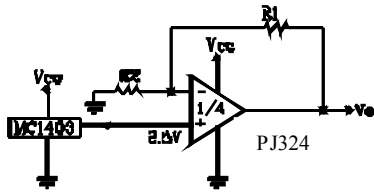

Figure 6. Input Bias Current versus Power Supply Voltage



Quad Low Power Operational Amplifiers

Figure 7. Voltage Reference



$$V_o = 2.5V (1 + R1 / R2)$$

Figure 8. Wlen Bridge Oscillator

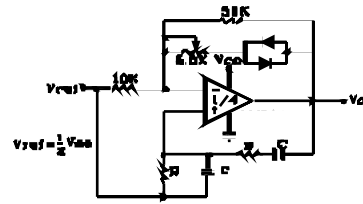

$$f_o = 1 / (2 \pi RC)$$

For: $f_o = 1.0\text{KHz}$

$R = 16\text{K} \Omega$

$C = 0.01 \mu\text{F}$

Figure 9. High Impedance Differential Amplifier

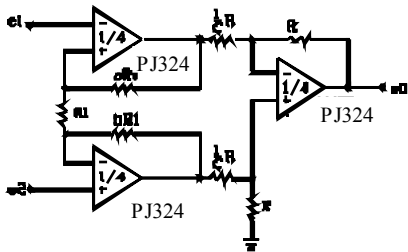

$$e_o = C(1+a+b)(e_2 - e_1)$$

Figure 10. Comparator with Hysteresis

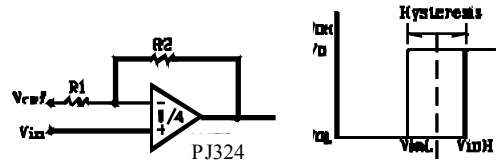

$$V_{inL} = R1 / (R1 + R2) (V_{OL} - V_{ref}) + V_{ref}$$

$$V_{inH} = R1 / (R1 + R2) (V_{OH} - V_{ref}) + V_{ref}$$

$$H = R1 / (R1 + R2) (V_{OH} - V_{OL})$$

Figure 11. Bi-Quad Filter

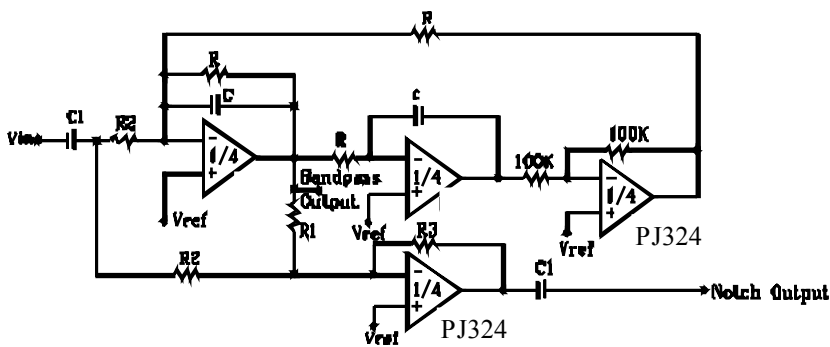

$$f_o = 1 / (2 \pi RC)$$

$R1 = OR$

$R2 = R1 / T_{BP} \quad V_{ref} = 1/2$

$R3 = T_{NR2}$

$C1 = 10C$

For: $f_o = 1.0\text{KHz}$

$Q = 10$

$T_{BP} = 1$

$T_N = 1$

$R = 160\text{K} \Omega$

$C = 0.001 \mu\text{F}$

$R1 = 1.6\text{M} \Omega$

$R2 = 1.6\text{M} \Omega$

$R3 = 1.6\text{M} \Omega$

Where: T_{BP} = Center Frequency
Gain
 T_N = Passband Notch Gain

Quad Low Power Operational Amplifiers

Figure 12. Function Generator

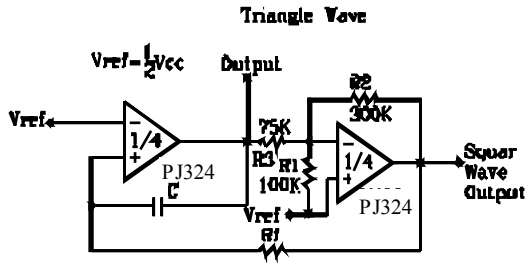

$$f = \frac{(R1+R2)}{4CR1}$$

$$R3 = \frac{(R2R1)}{(R2+R1)}$$

Figure 13. Multiple Feedback Bandpass Filter

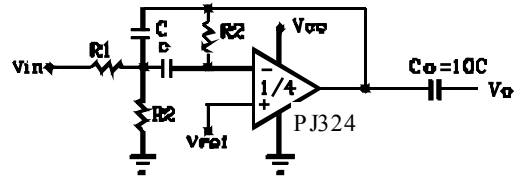

Given: f_0 = center frequency
 $A(f_0)$ = gain at center frequency
 Choose value f_0 C
 Then:

$$R3 = \frac{Q}{\pi f_0 C}$$

$$R1 = \frac{R3}{2A f_0}$$

$$R2 = \frac{(R1R3)}{(4Q^2R1 - R3)}$$

For less than 10% error operational amplifier
 $Q_0 f_0 < 0.1$ where f_0 and BW are expressed in Hz
 BW
 If source impedance varies, filter may be preceded with voltage follow buffer to stabilize filter parameters.

Quad Low Power Operational Amplifiers

DIP-14

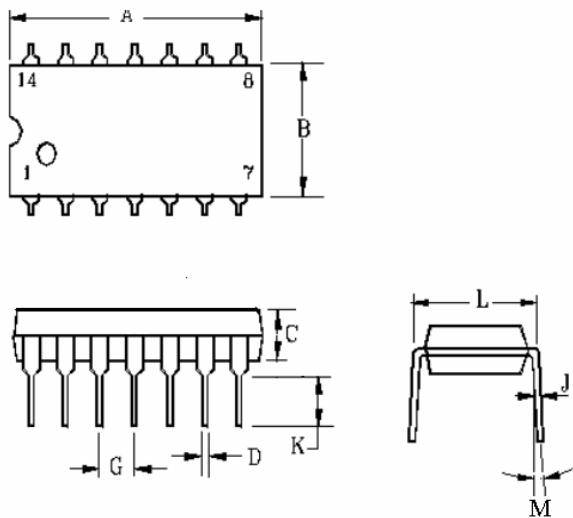

DIM	MILLIMETERS		INCHES	
	MIN	MAX	MIN	MAX
A	18.55	19.56	0.73	0.77
B	6.22	6.48	0.245	0.255
C	3.18	4.43	0.125	0.135
D	0.35	0.55	0.019	0.020
G	2.54BSC		0.10BSC	
J	0.29	0.31	0.011	0.012
K	3.25	3.35	0.128	0.132
L	7.75	8.00	0.305	0.315
M	-	10°	-	10°

SOP-14

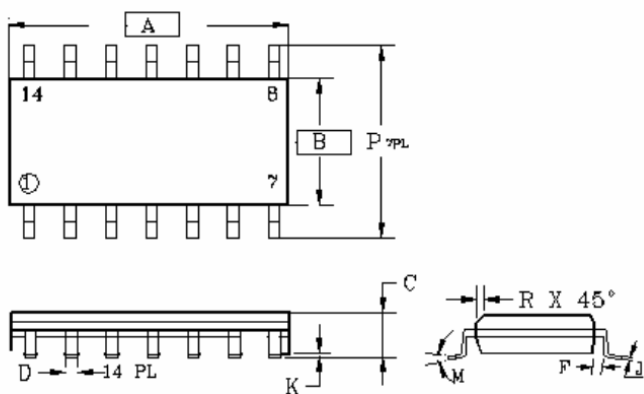

DIM	MILLIMETERS		INCHES	
	MIN	MAX	MIN	MAX
A	8.55	8.75	0.337	0.344
B	3.80	4.00	0.150	0.157
C	1.35	1.75	0.054	0.068
D	0.35	0.49	0.014	0.019
F	0.40	1.25	0.016	0.049
G	1.27BSC		0.05BSC	
K	0.10	0.25	0.004	0.009
M	0°	7°	0°	7°
P	5.80	6.20	0.229	0.244
R	0.25	0.50	0.010	0.019