

Wireless Audio Link IC

BH1415F

The BH1415F is a FM stereo transmitter IC that transmits simple configuration. The IC consists of a stereo modulator for generating stereo composite signals and a FM transmitter for broadcasting a FM signal on the air. The stereo modulator generates a composite signal which consists of the MAIN, SUB, and pilot signal from a 38kHz oscillator. The FM transmitter radiates FM wave on the air by modulating the carrier signal with a composite signal.

●Applications

CD changer, Car TV, Car navigation, Wireless speakers, Personal computer (sound board), Game machine

●Features

- 1) It is possible to improve the timbre because it has the pre-emphasis circuit, limiter circuit, and the low-pass filter circuit.
- 2) Built-in pilot-tone system FM stereo modulator circuit.
- 3) The transmission frequency is stable because it has a PLL system FM transmitter circuit.
- 4) PLL data input (CE, CK, DA) by serial input.

●Absolute maximum ratings (Ta = 25°C, In measurement circuit.)

Parameter	Symbol	Limits	Unit	Conditions
Supply voltage	V _{CC}	+7.0	V	Pin8,12
Data input voltage	V _{IN-D}	-0.3~V _{CC} +0.3	V	Pin15,16,17,18
Phase comparator output voltage	V _{OUT-P}	-0.3~V _{CC} +0.3	V	Pin7
Power dissipation	P _d	450*	mW	
Storage temperature	T _{stg}	-55~+125	°C	

* Derating : 4.5mW/°C for operation above Ta=25°C.

●Recommended operating conditions (Ta = 25°C)

Parameter	Symbol	Min.	Typ.	Max.	Unit	Conditions
Operating supply voltage	V _{CC}	4.0	–	6.0	V	Pin8,12
Operating temperature	T _{opr}	-40	–	+85	°C	
Audio input level	V _{IN-A}	–	–	-10	dBV	Pin1,22
Audio input frequency band	f _{IN-A}	20	–	15k	Hz	Pin1,22
Pre-emphasis time constant set up range	t _{PRE}	–	–	155	μsec	Pin2,21
Transmission frequency	f _{TX}	70	–	120	MHz	Pin9,11
Control terminal "H" level input voltage	V _{IH}	0.8V _{CC}	–	V _{CC}	V	Pin15,16,17,18
Control terminal "L" level input voltage	V _{IL}	GND	–	0.2V _{CC}	V	Pin15,16,17,18

●Block diagram

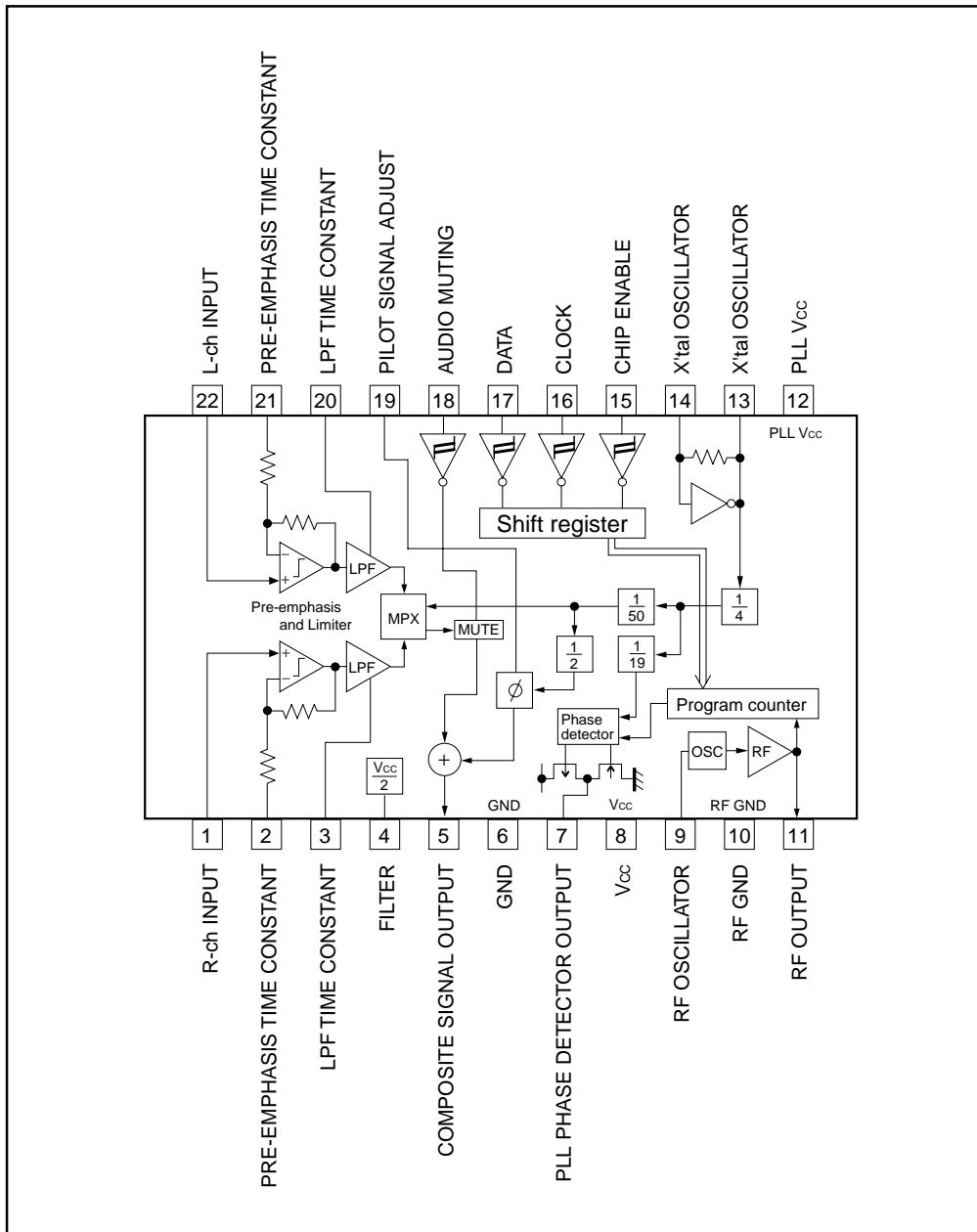

Audio ICs

● Pin descriptions

Pin No.	Pin descriptions	Equivalent circuit	DC (V)
1	R-ch audio source input terminal It cuts DC with the capacitor and it inputs R-ch audio signal.		$\frac{1}{2}V_{CC}$
22	L-ch audio source input terminal It cuts DC with the capacitor and it inputs L-ch audio signal.		$\frac{1}{2}V_{CC}$
2,21	Pre-emphasis time constant terminal It connects a capacitor for the time constant of pre-emphasis. $\tau = 22.7k\Omega \times C$		$\frac{1}{2}V_{CC}$
3,20	LPF time constant terminal This is 15kHz LPF. It connects a 150pF capacitor.		$\frac{1}{2}V_{CC}$
4	Filter terminal It is a ripple filter for the reference voltage of the audio part.		$\frac{1}{2}V_{CC}$
5	Composite signal output terminal It connects to the FM modulator.		$\frac{1}{2}V_{CC}$
6	GND	—	GND
7	PLL phase detector output terminal It connects to the PLL LPF circuit.		—
8	Power supply terminal	—	V_{CC}

Audio ICs

Pin No.	Pin descriptions	Equivalent circuit	DC (V)
9	RF oscillator terminal This is the base terminal of the colpitts oscillator. It connects time constant of the oscillation.		$\frac{4}{7}V_{CC}$
10	RF GND	—————	GND
11	RF transmission output terminal It connects to the antenna through BPF.		$V_{CC} - 1.9$
12	PLL power supply terminal	—————	V_{CC}
13,14	X'tal oscillator terminal It connects a 7.6MHz crystal oscillator.		—
15	Chip enable terminal The terminal to make high level in serial data input.		—
16	Clock input terminal The clock which takes data and synchronization in serial data input.		
17	Data input terminal The input terminal of the serial data which is forwarded from the controller		
18	Audio mute terminal $0.8V_{CC} \leq \text{Pin18}$: Mute ON $0.2V_{CC} \geq \text{Pin18}$: Mute OFF		
19	Pilot signal adjust terminal		$\frac{1}{2}V_{CC}$

Audio ICs

●Electrical characteristics (Unless otherwise noted $T_a = 25^\circ\text{C}$, $V_{CC} = 5.0\text{V}$, Signal source : $f_{IN} = 400\text{Hz}$)

Parameter	Symbol	Min.	Typ.	Max.	Unit	Conditions	Measurement circuit
Quiescent current	I_Q	14	20	28	mA		Fig.1
Channel separation	Sep	25	40	-	dB	$V_{IN} = -20\text{dBV}$ L→R, R→L	Fig.2
Total harmonic distortion	THD	-	0.1	0.3	%	$V_{IN} = -20\text{dBV}$ L+R	Fig.3
Channel balance	C.B	-2	0	+2	dB	$V_{IN} = -20\text{dBV}$ L+R	Fig.2
Input output gain	G_V	-2	0	+2	dB	$V_{IN} = -20\text{dBV}$ L+R	Fig.3
Pilot modulation rate	M_P	12	15	18	%	$V_{IN} = -20\text{dBV}$, L+R Pin5	Fig.3
Sub carrier rejection ratio	SCR	-	-30	-20	dB	$V_{IN} = -20\text{dBV}$ L+R	Fig.3
Pre-emphasis time constant	τ_{PRE}	40	50	60	μsec	$V_{IN} = -20\text{dBV}$ L+R	Fig.3
Limiter input level	$V_{IN(LIM)}$	-16	-13	-10	dBV	Output level at 1dB gain compression	Fig.4
LPF cut off frequency	$f_{C(LPF)}$	12	15	18	kHz	$V_O = -3\text{dB}$ Pin2,21Open	Fig.5
Mute attenuation volume	$V_{O(MUTE)}$	-	-48	-42	dB	$V_{IN} = -20\text{dBV}$ L+R	Fig.3
Transmission output level	V_{TX}	97	100	103	dB μV	$f_{TX} = 100\text{MHz}$	Fig.6
"H" level input current	I_{IH}	-	-	1.0	μA	Pin15,16,17,18 $V_{IN} = 5\text{V}$	Fig.7
"L" level input current	I_{IL}	-1.0	-	-	μA	Pin15,16,17,18 $V_{IN} = 0\text{V}$	Fig.7
"H" level output voltage	V_{OH}	$V_{CC} - 1.0$	$V_{CC} - 0.15$	-	V	Pin7 $I_{OUT} = -1.0\text{mA}$	Fig.7
"L" level output voltage	V_{OL}	-	0.15	1.0	V	Pin7 $I_{OUT} = 1.0\text{mA}$	Fig.7
"off" level leak current1	I_{OFF1}	-	-	100	nA	Pin7 $V_{OUT} = 5\text{V}$	Fig.8
"off" level leak current2	I_{OFF2}	-100	-	-	nA	Pin7 $V_{OUT} = \text{GND}$	Fig.8

Audio ICs

● Measurement circuits

Quiescent current

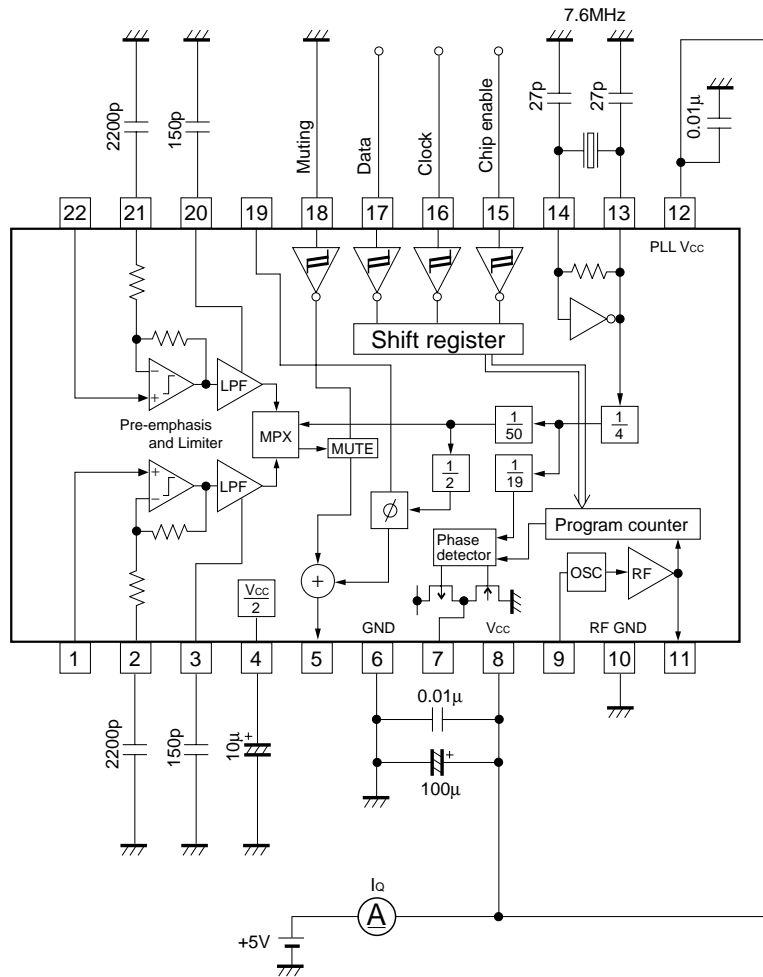

Fig.1

Audio ICs

Channel separation
Channel balance

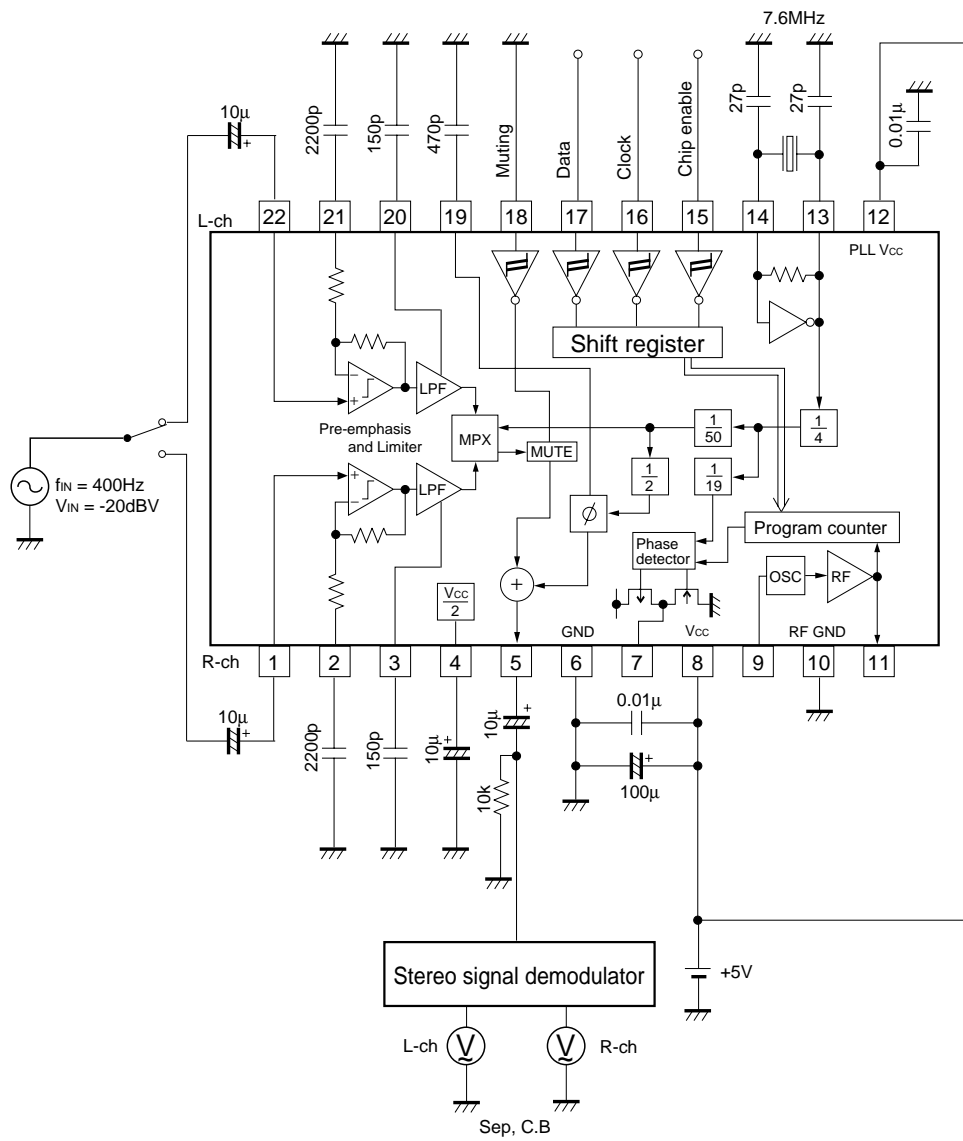

Fig.2

Audio ICs

- Total harmonic distortion
- Input output gain
- Pilot index of modulation
- Sub carrier rejection ratio
- Pre-emphasis time constant
- Mute attenuation volume

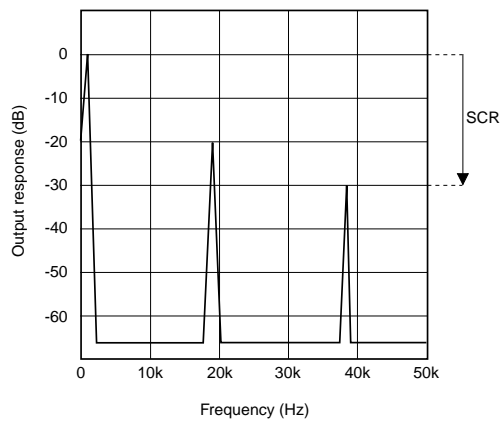
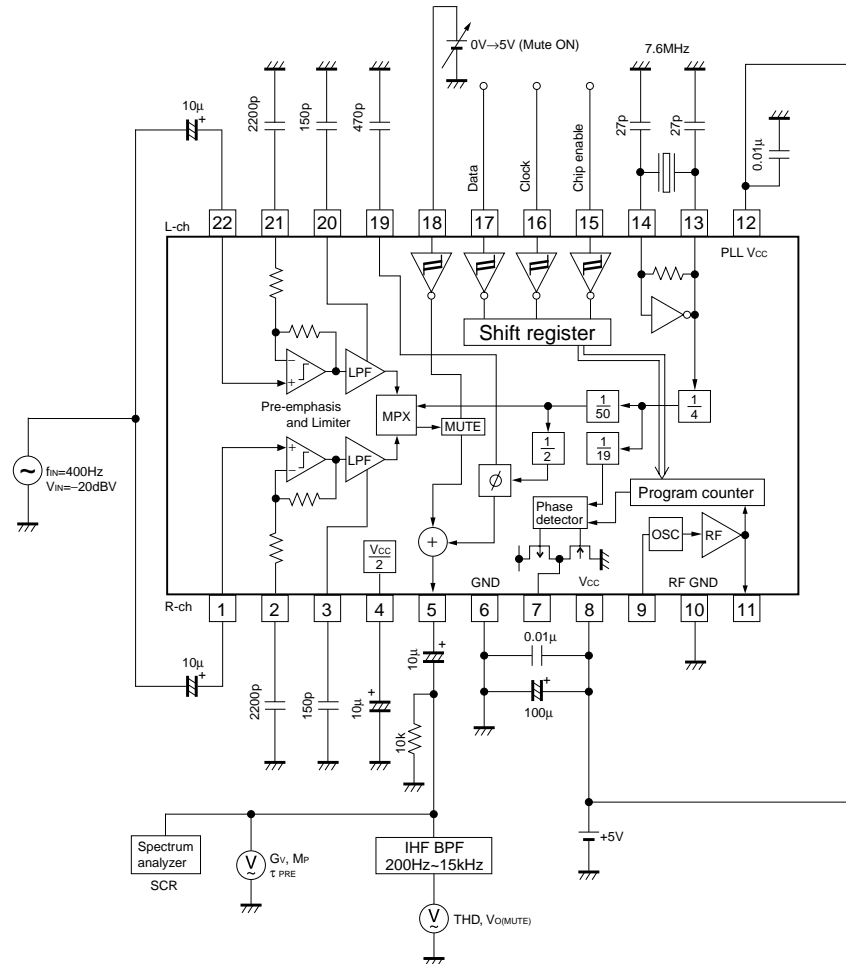

Fig.3

Audio ICs

Limiter input level

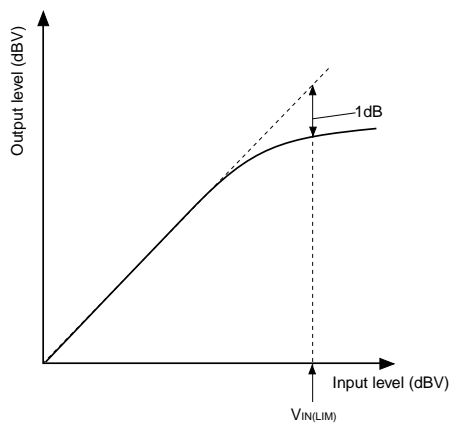
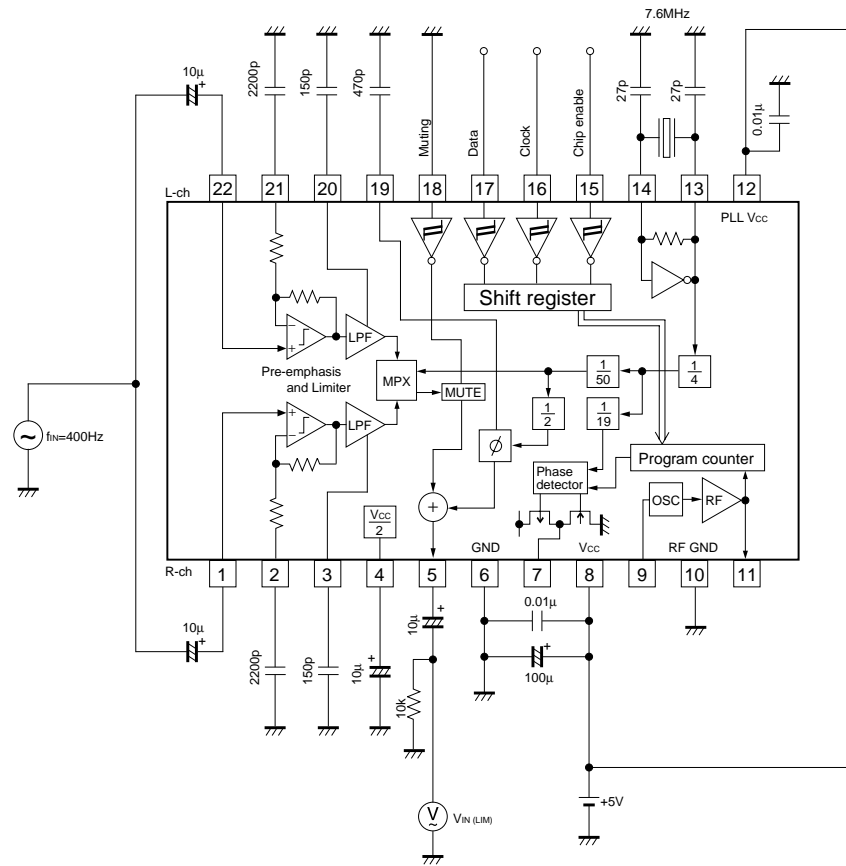

Fig.4

Audio ICs

LPF cut off frequency

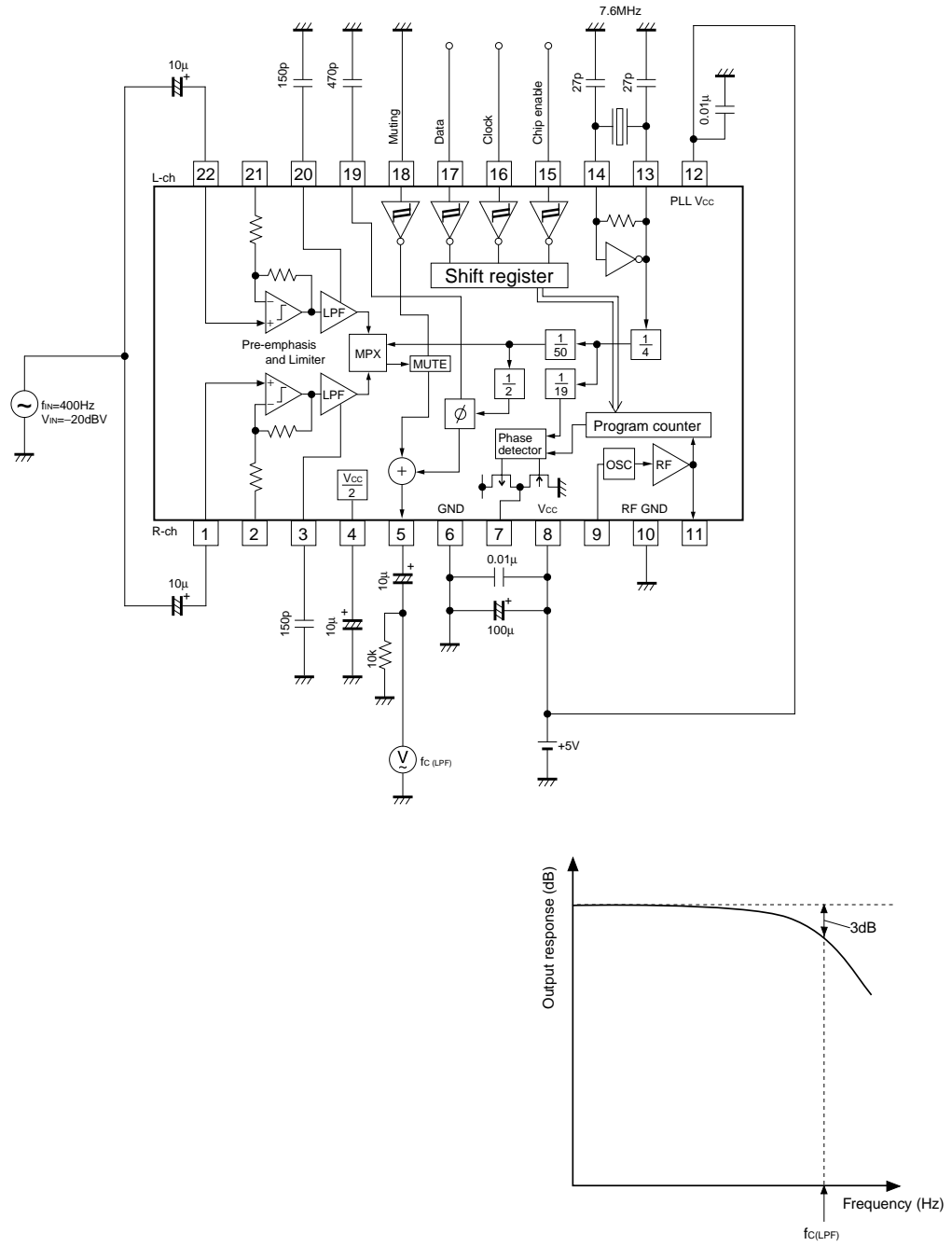

Fig.5

Transmission output level

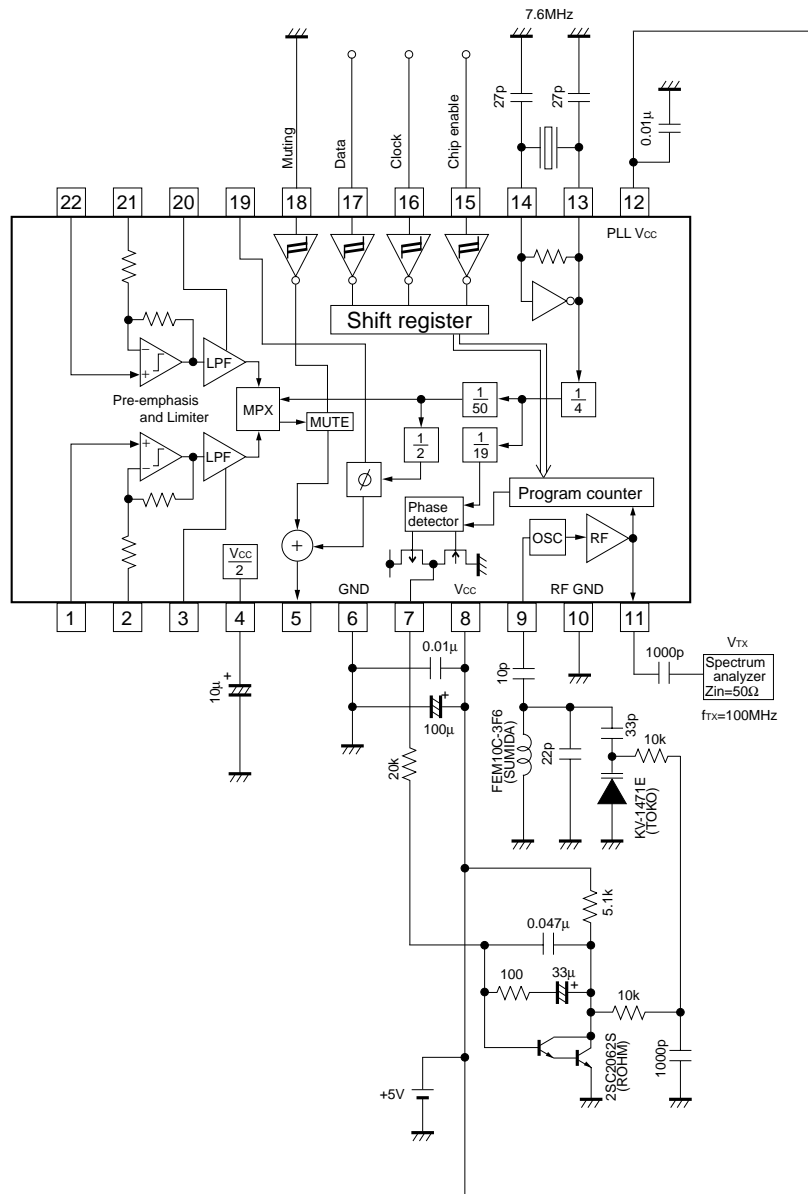

Fig.6

Audio ICs

- “H” level input current
- “L” level input current
- “H” level output voltage
- “L” level output voltage

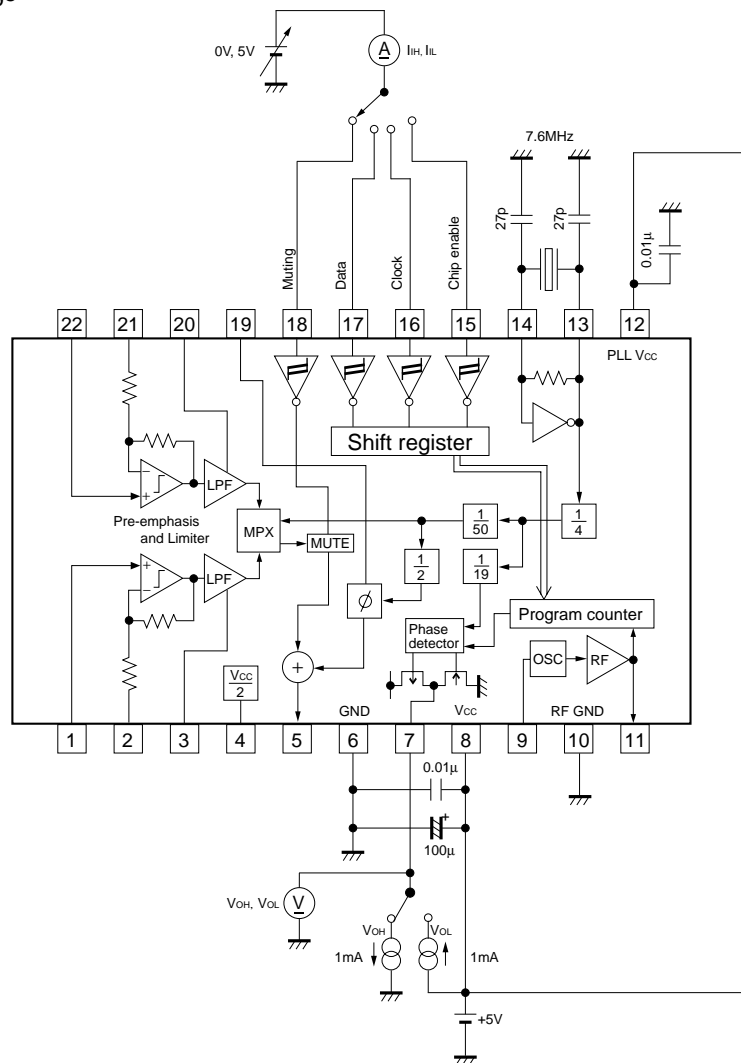

Fig.7

“off” level leak input current

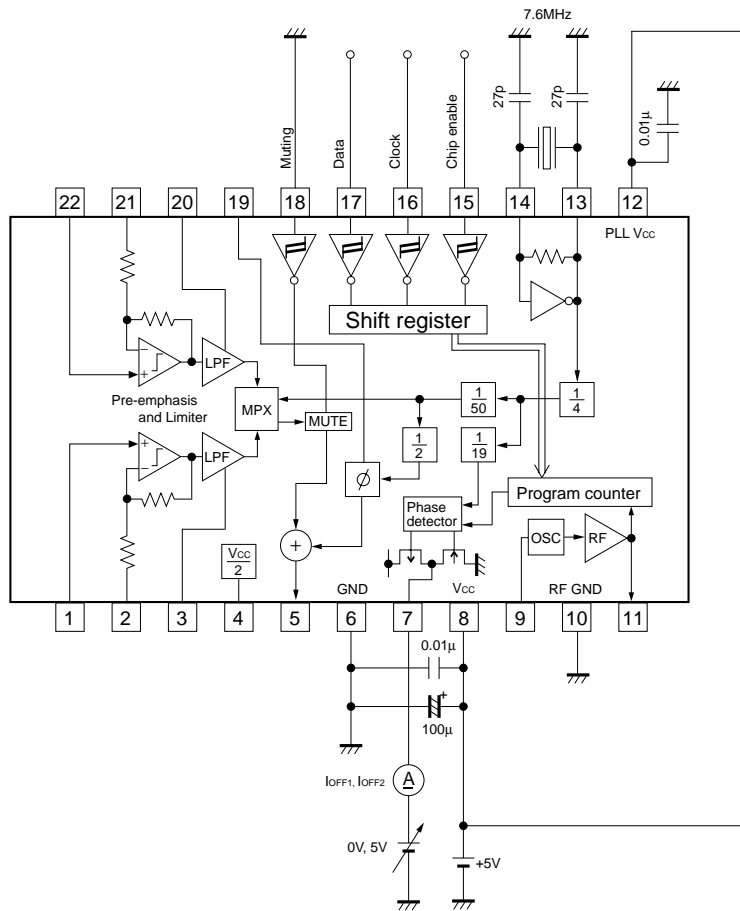

Fig.8

Audio ICs

●Circuit operations

Input of the serial data

$t_1, t_2, t_3, t_4 \geq 1.5\mu\text{sec}$
 $t_5 < 1.5\mu\text{sec}$ (X'tal : 7.6MHz)

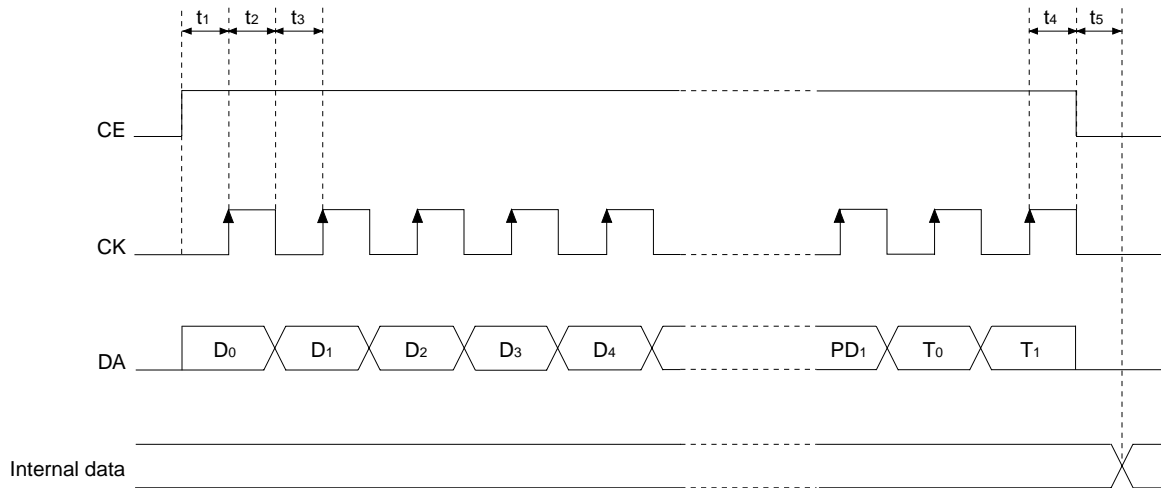

Composition of the serial data

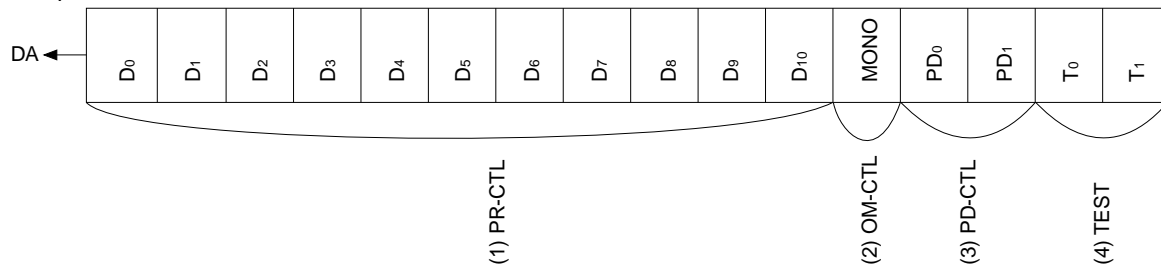

Explanation of the serial data

No.	Control unit / Data	Contents																																												
(1)	PROGRAM COUNTER D ₀ ~ D ₁₀	<ul style="list-style-type: none"> It is the data which sets the program counter number of the dividing. This data can set a transmission frequency. It is a binary value. It sets D₁₀ with MSB and it sets D₀ with LSB. <p>Example In case of 99.7MHz oscillation $99.7\text{MHz} \div 100\text{kHz}(\text{fref}) = 997 \rightarrow 3\text{E5}(\text{HEX})$</p> <div style="text-align: center;"> <table border="1" style="margin: auto;"> <tr> <td colspan="5">5</td> <td colspan="3">E</td> <td colspan="3">3</td> </tr> <tr> <td>1</td><td>0</td><td>1</td><td>0</td><td>0</td><td>1</td><td>1</td><td>1</td><td>1</td><td>1</td><td>0</td> </tr> <tr> <td>D₀</td><td>D₁</td><td>D₂</td><td>D₃</td><td>D₄</td><td>D₅</td><td>D₆</td><td>D₇</td><td>D₈</td><td>D₉</td><td>D₁₀</td> </tr> <tr> <td colspan="5">LSB</td> <td colspan="3"></td> <td colspan="3">MSB</td> </tr> </table> </div>	5					E			3			1	0	1	0	0	1	1	1	1	1	0	D ₀	D ₁	D ₂	D ₃	D ₄	D ₅	D ₆	D ₇	D ₈	D ₉	D ₁₀	LSB								MSB		
5					E			3																																						
1	0	1	0	0	1	1	1	1	1	0																																				
D ₀	D ₁	D ₂	D ₃	D ₄	D ₅	D ₆	D ₇	D ₈	D ₉	D ₁₀																																				
LSB								MSB																																						

Audio ICs

No.	Control unit / Data	Contents															
(2)	MULTIPLEXER MONO	<ul style="list-style-type: none"> It changes a stereo and monaural operation. <table border="1"> <thead> <tr> <th>MONO</th> <th>Condition of the composite signal</th> </tr> </thead> <tbody> <tr> <td>0</td> <td>Monaural operation L+R , Pilot OFF</td> </tr> <tr> <td>1</td> <td>Stereo operation $L+R+(L-R)\sin\omega_s t+P\sin\frac{\omega_s}{2} t$</td> </tr> </tbody> </table>	MONO	Condition of the composite signal	0	Monaural operation L+R , Pilot OFF	1	Stereo operation $L+R+(L-R)\sin\omega_s t+P\sin\frac{\omega_s}{2} t$									
MONO	Condition of the composite signal																
0	Monaural operation L+R , Pilot OFF																
1	Stereo operation $L+R+(L-R)\sin\omega_s t+P\sin\frac{\omega_s}{2} t$																
(2)	PHASE DETECTOR PD ₀ , PD ₁	<ul style="list-style-type: none"> It controls charge pump output by the phase comparator compulsorily. <table border="1"> <thead> <tr> <th>PD₀</th> <th>PD₁</th> <th>Charge pump output</th> </tr> </thead> <tbody> <tr> <td>0</td> <td>0</td> <td>Usual operation</td> </tr> <tr> <td>0</td> <td>1</td> <td>Compulsion by Low</td> </tr> <tr> <td>1</td> <td>0</td> <td>Compulsion by High</td> </tr> <tr> <td>1</td> <td>1</td> <td>High impedance</td> </tr> </tbody> </table>	PD ₀	PD ₁	Charge pump output	0	0	Usual operation	0	1	Compulsion by Low	1	0	Compulsion by High	1	1	High impedance
PD ₀	PD ₁	Charge pump output															
0	0	Usual operation															
0	1	Compulsion by Low															
1	0	Compulsion by High															
1	1	High impedance															
(3)	TEST MODE T ₀ , T ₁	<ul style="list-style-type: none"> It is data for the LSI test. Always in T₀ Input "1". Always in T₁ Input "0". 															

●External dimensions (Units : mm)

