

750

## REMOTE CONTROL VEHICLE SECURITY SYSTEM INSTALLATION INSTRUCTIONS

*The individual delivering the vehicle should review the operation of the vehicle security system, including the location of the valet switch, disarm button and any additional accessories with the customer. Please give the owners manual to the customer.*

### IMPORTANT INSTALLATION NOTICES

**This system requires following a special power-up and programming procedure before the system will operate properly. Complete the power-up and programming steps, beginning on page 9, prior to attempting operation of this system.**

Soldering and solderless crimp connectors are the best methods for making wire to wire connections when installing this vehicle security system. "Self-tapping" type connectors are not recommended for making wire to wire connections when installing this system.

Using "LIGHT BULB" type test lights may cause damage to some vehicle electrical systems. It is **HIGHLY RECOMMENDED** that you use a **VOLTMETER** or **DIGITAL LOGIC PROBE** when testing vehicle electrical circuits. An improper connection can cause serious damage to the vehicle and/or security system components.

**This system is designed for professional installation, there are no user serviceable components. Do not attempt to open the module case, doing so will void all warranties. If service is required return the product to an authorized dealer.**

This device complies with FCC rules part 15. Operation is subject to the following two conditions: (1) this device may not cause harmful interference and (2) this device must accept any interference that may cause undesired operation.

Changes or modifications not expressly approved by the party responsible for compliance could void the user's authority to operate the equipment.

MFG# Y-3  
INS0680  
4/95

This product is protected by U.S. patent number 5,049,867  
© Code Alarm, Inc. 1994 All rights reserved.  
Printed in the USA

# SYSTEM LAYOUT

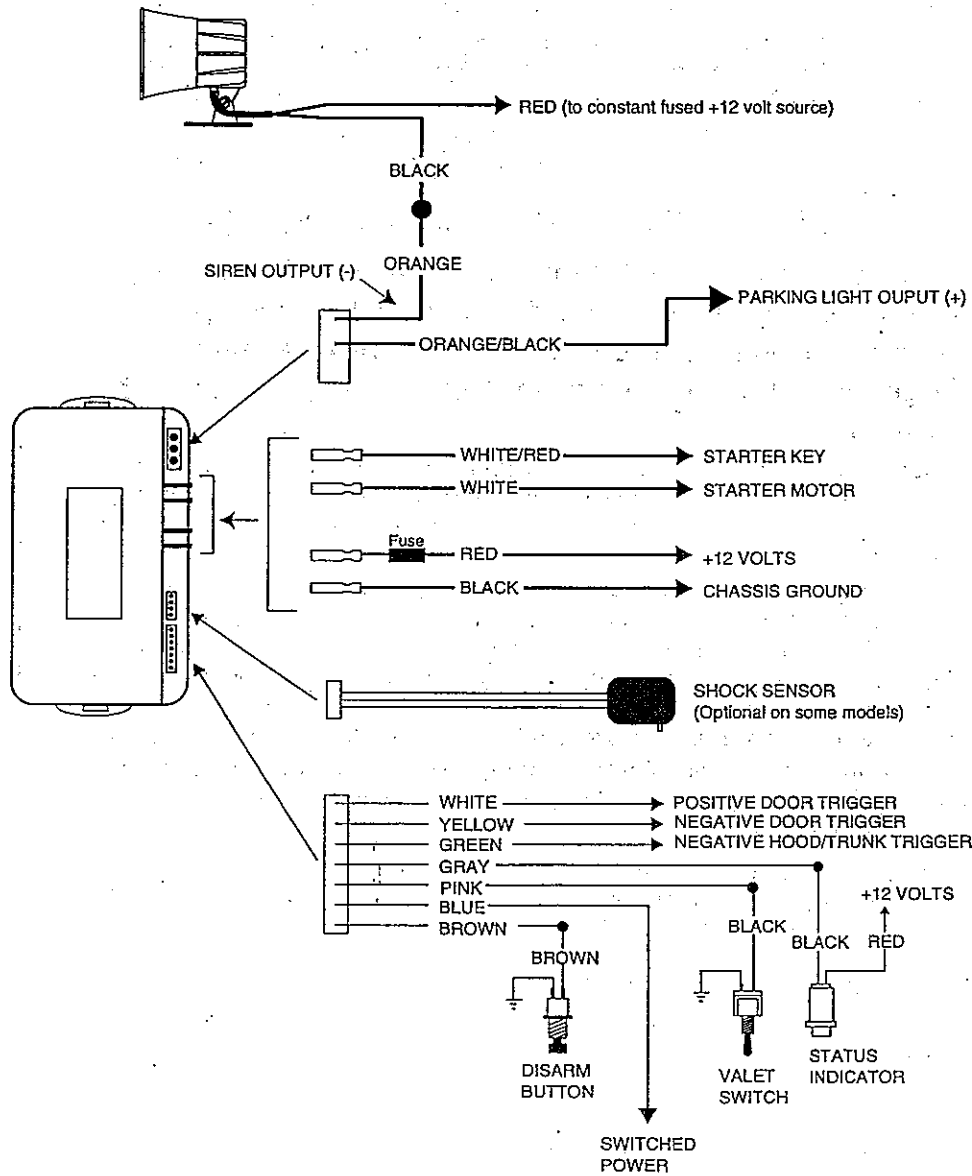

## STEP 1: INTERIOR PREPARATION

Remove interior panels and moldings as needed to access the underdash and ignition switch wiring.

## STEP 2: MODULE PREPARATION

1. Review the system layout and plan the system wire harness routing and connection points.
2. Plug all wiring harnesses and sensor(s) onto the module.
3. Remove all fuses from the wiring harnesses and set aside.
4. Using small tie wraps, bundle the wiring harnesses neatly together as shown in diagram 2. Leave the tie wrap(s) closest to the module loose at this time, you may want to run additional wires through them during the installation.
5. About 6" away from the module, begin branching the harness off into smaller groups bundling those wires together that will run to the same areas underdash.
6. Find a module mounting location underdash that will be as difficult as possible for a potential thief to find.
7. Temporarily mount the control module underdash and begin routing the wire harness.

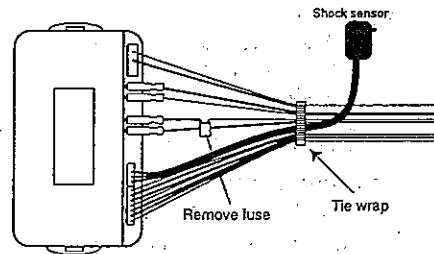

## STEP 3: SIREN MOUNTING & CONNECTION

1. Locate a suitable mounting location in the engine compartment for the siren. When evaluating possible mounting locations, make sure that the potential mounting location will be:
  - ▶ away from hot or moving engine components such as exhaust manifolds or steering linkages.
  - ▶ away from moving body parts such as flip up headlamps.
  - ▶ mounted to a metal body panel where the siren "bell" will be pointed downward.
  - ▶ where water splash is minimal.
2. Mount the siren using three (3) 1/4" sheet metal screws.
  - ▶ It is a good idea to apply a small amount of rust inhibiting paint to the siren mounting screws to prevent corrosion.

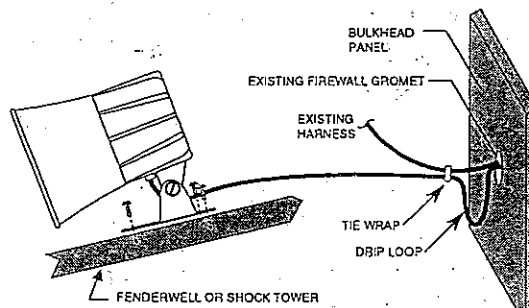

### STEP 3: SIREN MOUNTING & CONNECTION (CON'T)

3. Route the siren wires along existing vehicle wiring harnesses to the bulkhead panel.
  - ▶ Bundle the siren wires in black tape or convoluted tubing to blend in with other vehicle wiring harnesses for a "factory" appearance.
4. Route the siren wires through an existing firewall grommet, forming a drip loop as shown in diagram 3.1, to prevent water from running inside the vehicle through the wire opening.
  - ▶ On some vehicles, it may be necessary to drill a hole through the firewall to route the siren wires. In those cases, use extreme caution not to drill into any vehicle components.
5. Use a small amount of silicone sealant to completely seal the wire opening.
6. Inside the vehicle, route the siren wires to the module mounting location.
7. Connect the BLACK siren wire to the ORANGE module wire (dia. 3.2).
8. Connect the RED siren wire to a fused constant +12 volt source (dia. 3.2).

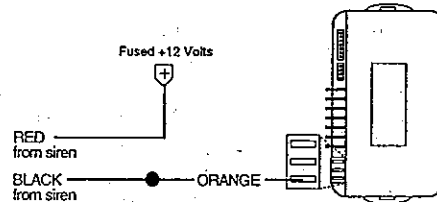

Diagram 3.2

### STEP 4: STARTER INTERRUPT

1. In the ignition switch wiring harness, find the "start" wire. The start wire will show +12 volts only when the ignition key is in the starting position.
2. At an accessible location, cut the vehicle start wire in half.
3. Attempt starting the engine to verify that the correct wire has been cut.
  - ▶ If the vehicle still starts it may have a second "start" wire.
4. Connect the module WHITE/RED wire to the KEY side of the vehicle start wire (dia. 4.1).
  - ▶ The KEY side of the start wire will still show +12 volts when the key is turned to the start position.
5. Connect the module WHITE wire to the STARTER side of the vehicle start wire (dia. 4.1).

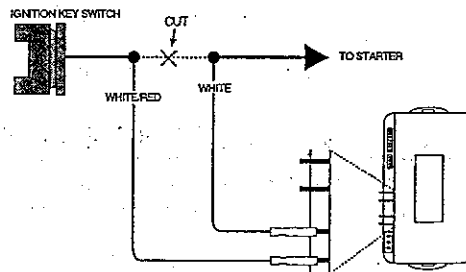

Diagram 4.1

#### Vehicles with two start wires:

*Some vehicles have two (2) "start" wires. If so they will originate from the same terminal on the ignition switch. Refer to the wire color and location chart if you are unsure if the vehicle you are working on has 2 start wires.*

- ▶ On vehicles that have 2 start wires, cut and interrupt both wires as shown in diagram 4.2.

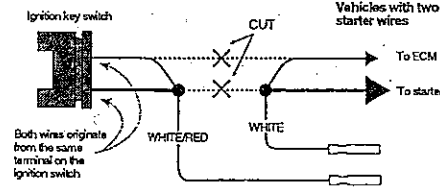
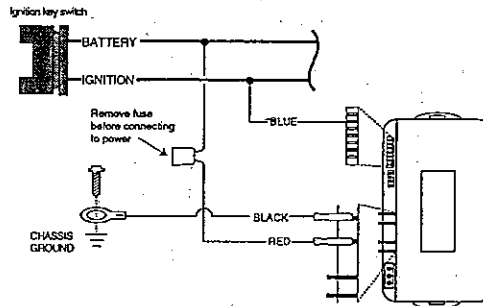

Diagram 4.2

## STEP 5: POWER AND GROUND CONNECTIONS

1. Connect the module RED wire to a vehicle constant power wire.
  - ▶ The target vehicle wire must be capable of supplying at least 15 amps. Do not tie the module RED wire into the vehicle courtesy light circuit.
2. Connect the module BLUE wire to a vehicle switched power wire.
  - ▶ The target vehicle wire must be energized when the ignition key is in the "RUN" and "CRANK" positions.
3. Connect the module BLACK wire to a solid chassis ground.
  - ▶ For the best possible ground connection, find a metal body panel and clean off any paint and corrosion. Next, crimp a ring terminal to the BLACK wire and secure the ring terminal to the metal body panel using a zinc coated sheet metal screw. Cover the ground point with a small amount of rust inhibiting paint or nonconductive grease to prevent corrosion.



## STEP 6: SHOCK SENSOR (OPTIONAL ON SOME SYSTEMS)

1. Select a mounting location for the shock sensor. The ignition switch wiring harness, steering column or a metal dash bracket are good choices. Choose a location that will allow access to the adjustment knob after the sensor is mounted.
2. Stick the supplied piece of two-sided tape to the bottom of the shock sensor case (dia 6.1). The two-sided tape will keep the sensor from sliding on the wire harness or mounting surface that the shock sensor is mounted to.
3. Using one of the supplied long tie wraps, secure the shock sensor to the selected mounting surface as shown (dia 6.2).
4. The shock sensor sensitivity setting will be adjusted during the system test procedures.
5. Plug the shock sensor 3-way connector onto the 4-pin header so that the pin next to the module BLACK wire is exposed as shown in diagram 6.3.

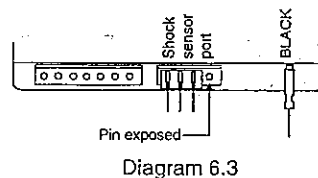
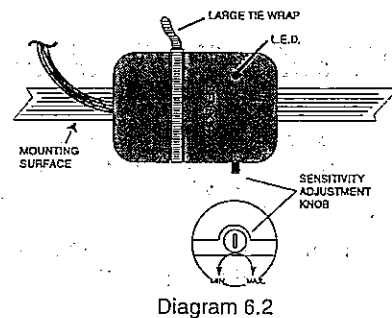
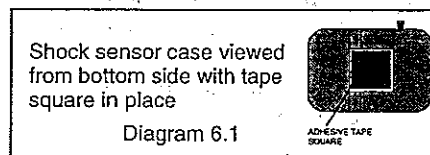

## STEP 7: DOOR TRIGGER INPUT

### Negative courtesy light circuit.

1. Locate an underdash courtesy light or door jamb switch. Identify the wire that shows ground when any door is open.
2. Connect the module 20 gauge YELLOW wire to the negative door trigger wire as shown in diagram 7.1.
3. Tape off the module 20 gauge WHITE wire.

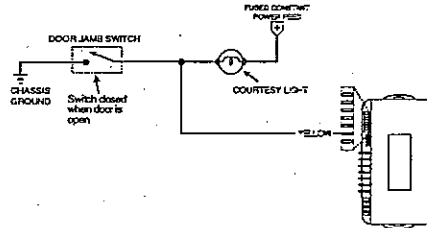

Diagram 7.1

### Positive courtesy light circuit (most FORD vehicles)

1. Locate an underdash courtesy light or door jamb switch. Identify the wire that shows +12 volts when any door is open.
2. Connect the module 20 gauge WHITE wire to the positive door trigger wire as shown in diagram 7.2.
3. Tape off the module 20 gauge YELLOW wire.

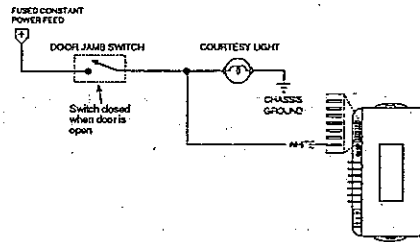

Diagram 7.2

## STEP 8: PIN SWITCHES/ADDITIONAL SENSORS (OPTIONAL)

- ▶ On vehicles that have a rear hatch with a separate dome light circuit trigger, connect the negative trigger from the rear hatch to the module GREEN wire.
- ▶ Connect hood and/or trunk pin switches to the module GREEN wire (on the seven (7) pin header).

### Additional sensors

When connecting additional sensors to the system, connect the trigger output from the additional sensor to the BROWN wire on the shock sensor as shown.

EXISTING SHOCK SENSOR CONNECTOR

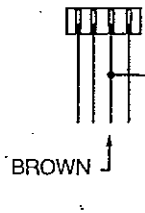

FROM SENSORS TRIGGER OUTPUT

## STEP 9: FLASHING PARKING LIGHTS

The flashing parking light output has a maximum rating of 10A. This output is not designed to flash headlamps. DO NOT connect this output to the vehicle's headlamps. Make the connection below that applies to the vehicle that you are working on.

### Positive polarity circuits

1. Locate the vehicle parking light wire. The correct wire will show +12 volts when the parking lights are on.
2. Connect the module ORANGE/BLACK wire to the vehicle's parking light wire.

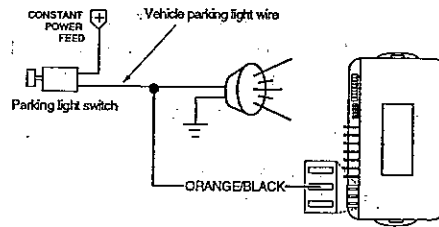

Diagram 13.1

### Negative polarity circuits

An external relay is required for this hookup.

1. Locate the vehicle parking light wire. The correct wire will show ground when the parking lights are on. This wire may show a positive voltage when the parking lights are off.
2. Connect the module ORANGE/BLACK wire to terminal #86 on the relay.
3. Connect both terminals #85 & #87 to chassis ground.
4. Connect terminal #30 to the vehicle parking light wire.

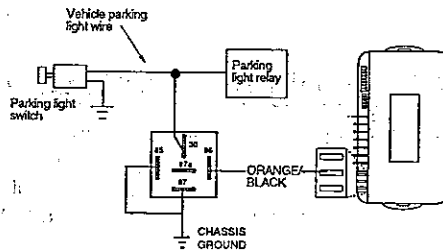
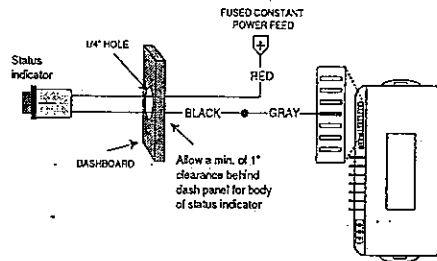

Diagram 13.2

## STEP 10: STATUS INDICATOR

1. Find a location on the dashboard to mount the status indicator that is visible from the outside of the vehicle. Make sure that there is at least 1" clearance behind the selected mounting area.
2. Drill 1/4" mounting hole.
3. Route the status indicator wires through the mounting hole and press the body of the status indicator into the mounting hole until it snaps in place.
4. Connect the status indicator BLACK wire to the module GRAY wire.
5. Connect the status indicator RED wire to a fused constant +12 volt source.



## STEP 11: VALET SWITCH

The valet switch must be installed on all automatic arming systems. The automatic arming option is enabled from the factory. If automatic arming is not desired, the automatic arming option may be disabled during the programming steps.

1. Find a suitable mounting location underdash for the valet switch that is accessible while sitting in the drivers seat.
2. Drill a 1/4" mounting hole and mount the valet switch as shown the diagram.
3. Connect one of the valet switch wires to the module PINK wire.
4. Connect the remaining valet switch wire to a solid chassis ground.

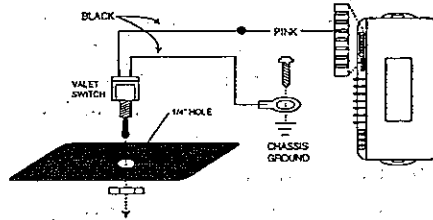

## STEP 12: OVERRIDE/PROGRAMMING BUTTON

The override/programming button must be installed for all installations.

1. Find a suitable mounting location for the override/programming button. The selected mounting location should be as difficult as possible for an unauthorized person to find. It is recommended that the override button be mounted in a different location in each installation.
2. Drill a 9/32" mounting hole in the selected mounting location and mount as shown in the diagram.
3. Connect one of the override button wires to the module BROWN wire.
4. Connect the remaining override/programming button wire to a solid chassis ground.

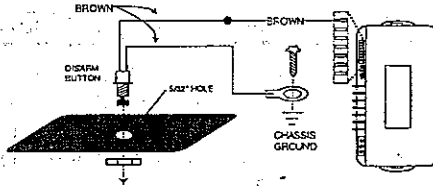



## SYSTEM POWER-UP

1. Double check all connections, making sure they are secure and well insulated.
2. Turn the ignition key to the "RUN" position.
3. Replace the main power fuse on the module RED wire.
4. If not going directly to the next step, turn the ignition off.

## TRANSMITTER PROGRAMMING

The transmitters must be programmed to the system prior to option programming, testing and system operation. The system has memory locations for four (4) transmitter codes. ALL FOUR MEMORY LOCATIONS MUST BE FILLED FOR THE SYSTEM TO OPERATE PROPERLY. UNLESS YOU ARE PROGRAMMING MORE THAN TWO TRANSMITTERS TO THE SYSTEM, PROGRAM EACH OF THE SUPPLIED TRANSMITTERS TWO (2) TIMES. IN ANY SITUATION, MAKE SURE THAT FOUR (4) TRANSMITTERS ARE PROGRAMMED TO THE SYSTEM AT ALL TIMES.

1. Open the drivers door and leave open.
2. If not already on, turn the ignition key to the "RUN" position.
3. Press and hold the programming button.  
*In 15 seconds the system will chirp three (3) times.*
4. Release the override/programming button.
5. Wait five (5) seconds.  
*The system is now in the transmitter learn mode.*
6. Press ARM button on the first transmitter.  
*The system will chirp the siren one time to indicate that this transmitter code has been learned.*
7. Repeat step 6 for transmitter #2 (programming each transmitter twice).
8. Turn the ignition key off to exit the learn mode.
9. Close all doors to reset the system operation.

Option programming steps on next page

## OPTION PROGRAMMING

**Note:** You can go into option programming mode without exiting the transmitter learn mode. To do so, do not turn the ignition key off or close the doors at the end of the transmitter programming section and proceed directly to step 2 below.

1. Enter the transmitter programming mode as indicated on page 13.
2. Press and release the programming button one time.  
*The siren will chirp three (3) times to indicate the system is in the option programming mode.*
3. Press the "A" button on the remote control transmitter one time to select option #1.  
*The siren will chirp one time.*
  - ▶ Pressing the DISARM button on a programmed transmitter toggles the selected option's state on or off.  
*The status indicator (LED) will display the state of the selected option.*
  - ▶ Pressing the ARM button on a programmed transmitter selects the next option.  
*The siren will emit a number of short chirps corresponding to the selected option number.*
  - ▶ Pressing "A" and "D" buttons at the same time will reset all options to their factory preset states.  
*The siren will chirp one time to indicating that the options have been reset to their factory preset programming.*
4. When all options are set as desired, turn the ignition key off to exit the options programming mode.
5. Close all doors to reset the system operation.

Selectable options	
#1 Arm/Disarm chirps	
LED ON	Arm/Disarm chirps enabled
LED OFF	Arm/Disarm chirps disabled
#2 Automatic arming	
LED ON	Automatic arming enabled
LED OFF	Automatic arming disabled

**Bold type indicates factory preset programming**

### Programmable features descriptions

#### Arm/Disarm chirps

When the system is armed the siren will emit 2 short chirps to confirm arming. On disarm the siren will emit one longer chirp to confirm the system is disarmed.

#### Automatic arming

The system will arm automatically after:

1. The ignition key is shut off.
2. A door is opened then closed.
3. One minute has elapsed after the door was closed.

## SYSTEM TEST AND ADJUSTMENT PROCEDURE

### Shock sensor sensitivity adjustment

1. Close all protected vehicle openings and arm system.
2. Wait at least 5 seconds.
3. Moving around the vehicle, using an open palm slap various body panels on the vehicle. A medium to heavy impact should trip a full alarm cycle.
4. Adjust the shock sensitivity up or down as need to achieve the desired setting.

### System test

Prior to mounting the module and reinstalling interior panel removed during the installation, check all connections and test all system functions. Make sure that all protected openings trip a full alarm cycle, the starter interrupt functions properly and that the valet switch and emergency override button works properly. Once all system functions have been tested and verified, go ahead and finish mounting the system control module, securing all wire harnesses and reinstall any interior panels removed during the installation. After reinstalling the interior components, retest the systems operation.

### Maximum ratings

Operating voltage	+7 VDC to +16 VDC
Operating temperature	-40C to +85C
Starter interrupt	30A (+)
Parking light output	10A (+)
Siren output	2A (-)
Status indicator output	26mA (-)
Negative trigger input threshold	0 - 4 VDC
Positive trigger input threshold	6 - 12 VDC

#### NOTE:

This system is equipped with an Output Short Circuit Protection feature. The OSCP feature will shut the system down for 10 seconds should any of the outputs exceed their rated outputs.

Q

C

Q

C

Q

C