



# Control unit AV and AV1

## CONTROL UNIT WITH EXTRACTIBLE MEMORY

### 1. Introduction.

Control unit for a motor in alternative current with torque adjuster (AV1), output contact for limit switch or Open/close buttons, selectable, output contact for photo dispositive, stop button, step-by-step, with radio modular and memory of expansion and possibilità to install an additional card for courtesy light and electrolock (AV1).

This control unit has been designed for the automation of rolling shutters, shutters and sliding doors.

### 2. Configuration.

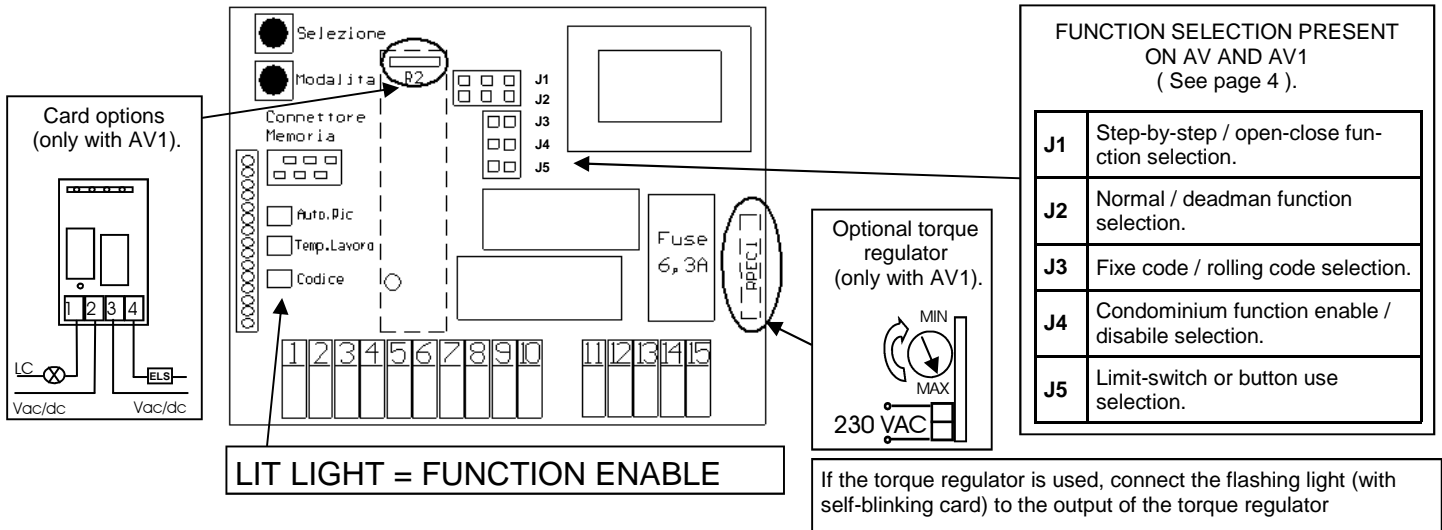

### 3. Electrical connections.

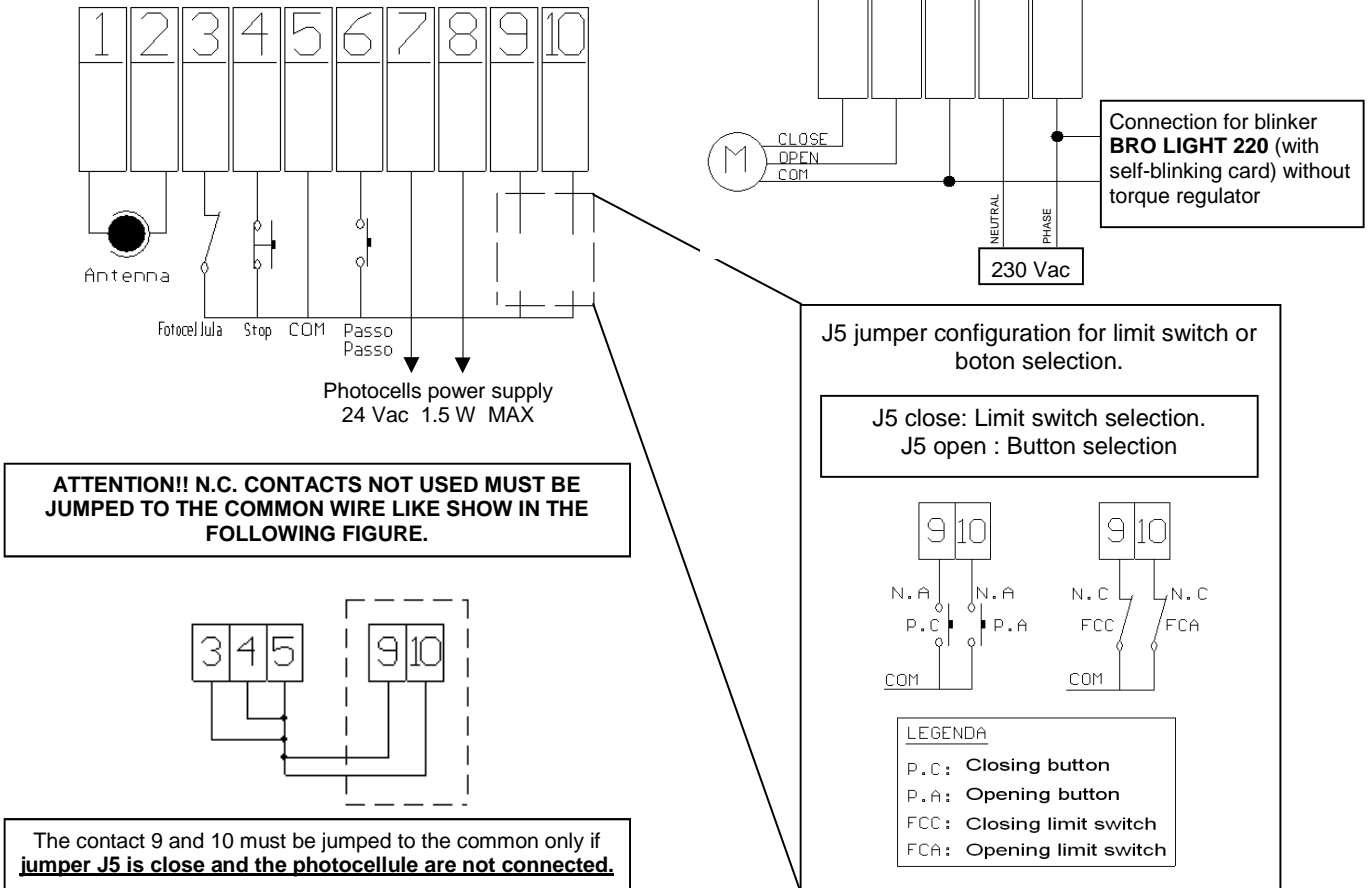

## 4. Learning.

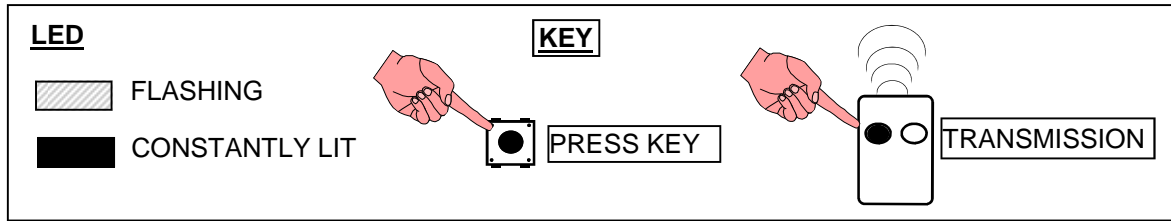

It's not possible to enter in the configuration menu with the automation in movement.  
**IT IS NECESSARY THAT THE AUTOMATION IS CLOSED !**

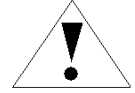

### 4.1 Remote control setting.

**Learning:**

- 1) Press the selection key, the **CODE** led is now flashing.
- 2) Press the radio control key "a". The control unit memorised automatically the second key "b" (Can be used like pedestrian run).  
When the code led remains lit the learning operation is finished.

**CANCEL:**

- 1) Press the **SELECTION** key until the code led is flashing.
- 2) Press the **MODE** key. All the leds are now lit and at the end all the codes of the learned transmitters will be deleted (the **CODE** led remain off).

### 4.2 Setting the gate.

**Programming work time from 1 sec to 3 min.**  
 The control box is supplied with a work time of 3 min.

Work time setting:

- 1) Make sure the **GATE** is **CLOSED**.
- 2) Press 2 times the **SELECTION** key. The **WORK TIME** led is now flashing.
- 3) Press the **MODE** key: the automation start to **OPEN** and continue to open until the **MODE** key is released. It is at this point that the **WORK TIME** is memorised.
- 4) The **WORK TIME** LED flashes for a few seconds and the gate re-closes, after which it remains permanently ON.

In order to vary this time repeat the described procedure. If you want to obtain an INFINITE WORK TIME and use the limit switch, you will need to carry out the procedure by keeping the **MODE** key pressed for less than 1 second and the signal will be given from the **WORK TIME OFF** LED.

**ATTENTION:**  
**EVERY TIME THAT THE CONTROL UNIT IS TURNED ON THE WORKING TIME IS RELOADED. THE FIRST STEP BY STEP COMMAND IS ALWAYS OPEN EXCEPT WHEN THE OPEN LIMIT SWITCH ( IF PRESENT) IS ACTIVATED.**

## 5. Configuration.

### 5.1 Automatic closure.

**Programming of the automatic closure time from 4 seconds to 2 min.**  
 The unit is provided with an active automatic reclosure, the time set is 30 seconds.

Setting automatic re-closing time

- 1) Press 3 times on the **SELECTION** key, the **Auto close** led is now flashing.
- 2) Press the mode key: from this moment the number of flashig corresponds to the closure time in seconds. The first 3 seconds of pressing the key activates the closure; on releasing the key the automatic closure and the **AUTO CLOSE** LED remains lit. The re-closure occurs also in the pedestrian function if active.

The unit starts counting the reclosure as soon as it has reached a condition of complete opening, or as soon as the opening operational time is finished, or the opening control is activated. The reclosure takes place in no other intermediate phase of automation stop.

To disable the automatic closure, follow the procedure keeping the **MODE** KEY PRESSED FOR LESS THAN 3 SECONDS. On releasing the **AUTOMATIC RE-CLOSURE** LED remains off.

## 5.2 Pedestrian function.

**ENABLE**

PRESS 4 TIMES SEL

**SETTING THE PEDESTRIAN FEATURE**

The control box is supplied with the pedestrian feature deactivated. In order to use this function, the use of the 2nd transmitter channel is indispensable (see paragraph 4).

**Activation and setting:**

- 1) Press 4 times on the **SELECTION** key, **CODE** and **WORK TIME** are lit.
- 2) Press the **Mode** key, the **CODE** and **WORK TIME** led are now flashing.
- 3) Exit from the configuration menu.
- 4) Press step by step key, the automation starts to open and continue to open until **selection or mode** key are pressed. Once release the key, the motor stops and that position is memorised as pedestrian run. Now, the second channel learned (b) will manage the pedestrian function. If we want to change the pedestrian run, it's enough to repeat the procedure described upside.

**To disable the pedestrian function:**  
Use the **SELECTION** key to disable the pedestrian feature. (Led **CODE** and **WORK TIME** FLASHING). Pressing the **MODE** key again will disable the function with the relative signalling of the two LEDs: **CODE** and **WORK TIME ON** for a few seconds. If disabled, each time it is re-enabled, it will be necessary to reset the time.

## 5.3 Electric lock (only on AV1 with optional card).

**ENABLE**

PRESS 5 TIMES SEL

**TO DISABLE IT**

Use the **SELECTION** key on the electric lock ability (**WORK TIME & AUTO CLOSE LED FLASHING**). Pressing the **MODE** key again will disable the function with the relative signalling of the two LEDs: **WORK TIME** and **AUTO CLOSE LIT** for a few seconds. In the event that the function is activated on the AV version, you will note a delay of 1 second in the opening phase.

The control box is supplied with the function deactivated. To use this function, it's necessary to use the optional additional card.

There is an auxiliary output for the use of an electric lock. The activation time is **3 SECONDS** fixed. With a closed gate, giving a command of opening the activation is immediate and the gate has a delay of 1 second. The electric lock remains active for another two seconds after the start of the movement.

**To enable this function:**

1. Press 5 times the key **SELECTION**, the **WORK TIME & AUTO CLOSE** Led LIT
2. Pressing the **MODE** key once will **ENABLE** the **ELECTRIC LOCK** feature and the signal will be given by way of a few **FLASHES** of **WORK TIME** and **AUTO CLOSE**.

## 5.4 Allmatic or customized variable code:

**Enable**

PRESS 6 TIMES SEL

**TO ENABLE THE ALLMATIC VARIABLE CODE DECODING**

Act on the **SELECTION** key to use the new parameter (Led **CODE** and **AUT RECL. FLASHING**). A pressure of the **MODE** key shall again enable the Allmatic variable code coding, and the signalling will be given by the permanent lighting of the **CODE** and **AUT RECL** leds . Reset the control unit.

**Allmatic / Customized variable code:**  
The unit is fitted with the Allmatic variable decoding code.

**Enable:**

- 1) Press 6 times the key **SELECTION**, The **Code** and **Auto.ric** led are now lit.
- 2) Press the key **MODE**, The led **code** and **Auto ric** flash for a few second.
- 3) Reset the control unit pressing in the same time the key selection and mode.

## 5.5 Exit from the programming.

Every time that you alter the parameters the control box exits from the menu of this parameter. The time available to act on the settings is 10 seconds. Otherwise the control box automatically exits from the programming phase. Skipping the programming phase the 7th time that you press SEL determines the exit from the programming mode.

## 5.6 Reset.

To reset the control unit with the factory settings, or to vary between receipt with fixed code or variable code, press the **SELECTION AND MODE** keys **CONTEMPORARILY**: all the LEDs will light up, flash and then turn off.

## 6. Advanced programming:

### FUNCTIONS SELECTION

By operating on the jumpers present on the central control panel it is possible to personalize the automation. The table on the following page describes the working and the effect that the action on each single jumper has on the central control panel.

**N.B.: DISCONNECT THE POWER SUPPLY EACH TIME THAT YOU OPERATE THE JUMPER!!!**

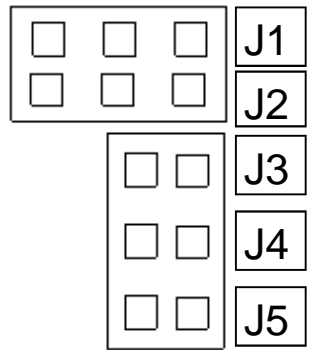

**IN ORDER TO MAKE THE PERSONALISATION PHASE EASIER IT IS ADVISABLE TO SET THE JUMPER BY REMOVING THE OPTIONAL ADDITIONAL CARD.**

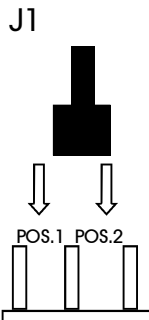
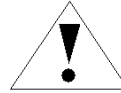

**POS.1:** The transmitter works in **IMPULSE MODE**. The memorised key runs these functions: **OPEN...STOP...CLOSE...STOP**.

**THE SECOND CHANNEL** memorised BY THE TRANSMITTER manages the PEDESTRIAN mode. (In this mode the transmitter cannot carry out either the deadman function or the normal working function).

**POS.2:** The **OPEN/CLOSE FUNCTION**, manages the automation acting on the 2 transmitter keys. The first commands the gate to open, the second to close. J1 in position 2 has another possibility of personalising the central computer acting on jumper 2.

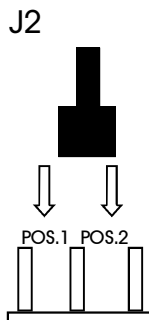
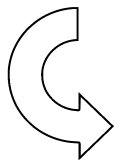

**POS.1:** Determines the **NORMAL WORKING** of the wall keys and the transmitter. By pressing the open key the gate opens completely, pressing the key a second time blocks the gate. If it is necessary to stop the movement it is necessary to press the key relative to the other direction, in this case the close key. To close re-press the close key. The same applies to open the gate.

**-In this J2 configuration the intervention of the photoelectric cells during closure blocks the gate and inverts the movement.**

**POS.2:** Determines the **PERSON PRESENT** function both with the keys on the wall and the transmitter (if jumper 1 = POS.2). The automation begins to open or close for the precision time of the relative transmitter button or the key.

**-In this J2 configuration the intervention of the photoelectric cells stops the movement until the obstacle has been removed. The movement will re-commence, either opening or closing as selected.**

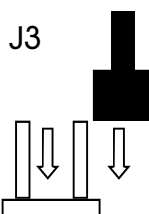

**OPEN:** The central computer allows **FIXED CODE** transmitter setting.  
**IN ORDER TO PASS FROM FIXED CODE TO VARIABLE AND VICE VERSA IT IS NECESSARY TO RESET THE CONTROL PANEL!**

**CLOSED:** The central computer allows **VARIABLE CODE** transmitter setting. The closure of the jumper **DECODE** gives another possibility of personalisation by acting on the jumper type **VARIABLE CODE**.

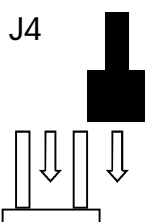

### Condominium function:

The unit is provided with a deactivated master function. The master function is activated and deactivated by using jumper J4.

**J4 CLOSED = CONDOMINIUM FUNCTION ACTIVATED**

**J4 OPEN = CONDOMINIUM FUNCTION DEACTIVATED**

To activate the master function, switch the unit first on and then

### CONDOMINIUM FUNCTION:

The opening mechanism starts with an impulse command when the gate is closed. Any other impulse command is ignored. Once completely opened, the reclosure is commanded only by time. If this is not set, the gate remains open without possibility of closing again.

For this reason a preset reclosing time of 30 seconds has been considered.

The photocell is engaged to reload the entire reclosing time when the gate is open. If the photocell remains interrupted the gate does not restart. During reclosure, an impulse command stops the unit and makes the automation totally reopen.

**7. Additional card for AV1 (not supplied as standard):**

The AV1 version has a connector (see diagram on page 1) where it is possible to insert an additional card in order to have the outputs for connection of the electric lock and the sensor light. The lighting time of the sensor light is fixed at 1 minute and 30 seconds. It lights each time the motor begins.

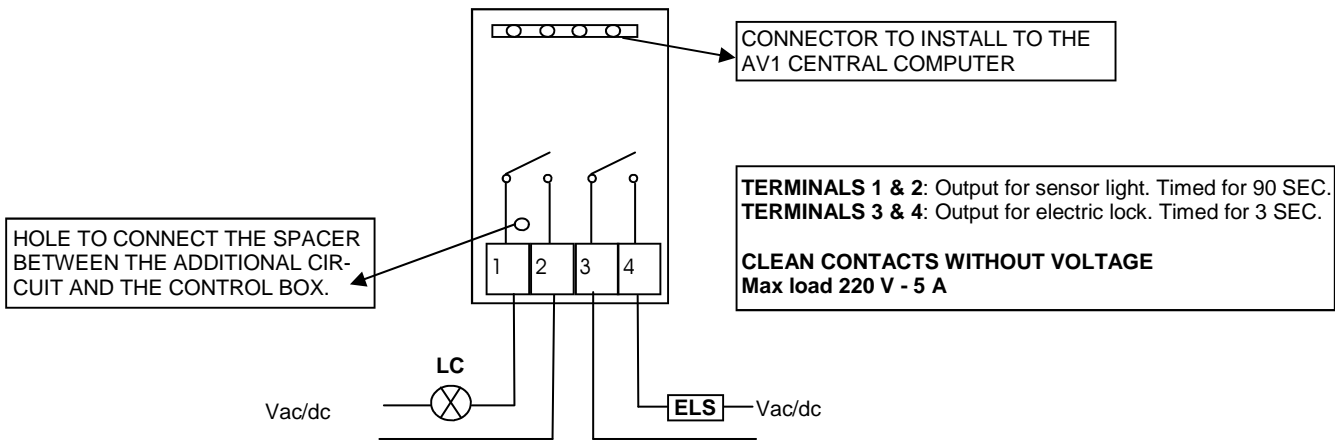

**WARNING:**

- Some points on the electrical control panel have a dangerously high voltage. Therefore the installation, the opening and the programming of the panel must be carried out by qualified personnel only.
- Use equipment that ensures the omnipolar disconnection of the system's power supply. This can be a switch (directly connected to the power terminals) with a minimum distance of the contacts of 3 mm in each pole, or a device integrated into the power network.
- It is advised that you control the absorption of all the devices connected to the control panel's outputs, such as pilot lights, photoelectric cells, safety devices etc. in order to enter within the limits shown in the technical details table. We cannot guarantee correct working of the product if these limits are not observed.
- In order to maximize the capacity of the central unit, it is necessary to pay attention to the antenna: it must not be directed towards walls and/or metallic screens. The terminals of the antenna's screened cable must be tightly closed.
- The tuned antenna is necessary in order to be able to obtain the maximum performance from the system. Contrarily the range could be reduced to a few metres.
- The manufacturer accepts no responsibility for damage caused by ignoring these warnings.

| <b>Technical details</b> |   |                           |                           |                             |
|--------------------------|---|---------------------------|---------------------------|-----------------------------|
| Power voltage            | 230 Vac +10% -15% 50Hz  |                           |                           |                             |
| Power accessories        | 24 Vac 1,5W MAX   |                           |                           |                             |
| Motor output             | 230Vac 500W MAX   |                           |                           |                             |
| Working temperature      | -10 +60 °C  |                           |                           |                             |
| Working time             | from 1 to 180 s   |                           |                           |                             |
| Automatic reclosure time | from 4 to 120 s   |                           |                           |                             |
| Receiver frequency       | 433.92 MHz  | 30.875 MHz quartz         | 40.665 MHz quartz         | 306 MHz (*) extra-reactive  |
| Available reception      | Fixed code<br>Rolling Code  | Fixed code                | Rolling Code              | Fixed code                  |
| Impedance of antenna     | 50 W  |                           |                           | * Device not for UE market. |
| Number of codes          | 4096 (receipt of fixed code)<br>18 billion billion (Rolling Code receipt) |                           |                           |                             |
| Capacity                 | 50-150 in unlimited space   | 50-150 in unlimited space | 50-150 in unlimited space | 50-150 in unlimited space   |

**GUARANTEE** - The producer's guarantee is valid in compliance with the law, from the date stamped on the product and is limited to repair work and free replacement of pieces recognised as faulty for problems with the quality and/or materials due to bad workmanship. The guarantee does not cover damage caused by foreign elements, maintenance errors, overloading, natural wear, incorrect choice, faults in the assembly, or other causes not controllable by the manufacturer. Products which have been tampered with are not covered by the guarantee and will not be repaired. The information stated here is purely indicative. No responsibility will be accepted for capacity reduction or malfunctions caused by environmental interferences. The reasonability that lies with the Producer for damage that derives from accidents of any kind caused by our faulty products is exclusively that which is stated in the Italian law.