

- |          |                |          |             |
|----------|----------------|----------|-------------|
| S1 a ~ b | SELECTOR       | S4 a ~ b | LOUDNESS    |
| 1        | PHONO          | 1        | OFF         |
| 2        | TUNER          | 2        | ON          |
| 3        | AUX            |          |             |
| S2 a ~ b | TAPE MONITOR 1 | S5 a ~ b | HIGH FILTER |
| 1        | SOURCE         | 1        | OFF         |
| 2        | MON. 1         | 2        | ON          |
| S3 a ~ b | TAPE MONITOR 2 | S6 a ~ b | SPEAKER     |
| 1        | SOURCE         | 1        | OFF         |
| 2        | MON. 2         | 2        | A           |
|          |                | 3        | B           |
|          |                | 4        | A + B       |

(v): DC VOLT AT NO INPUT SIGNAL.  
 □ v: DC VOLT AT 35W x 2 (80HM-1KHz)

# WIRING DIAGRAM

# TRM-650

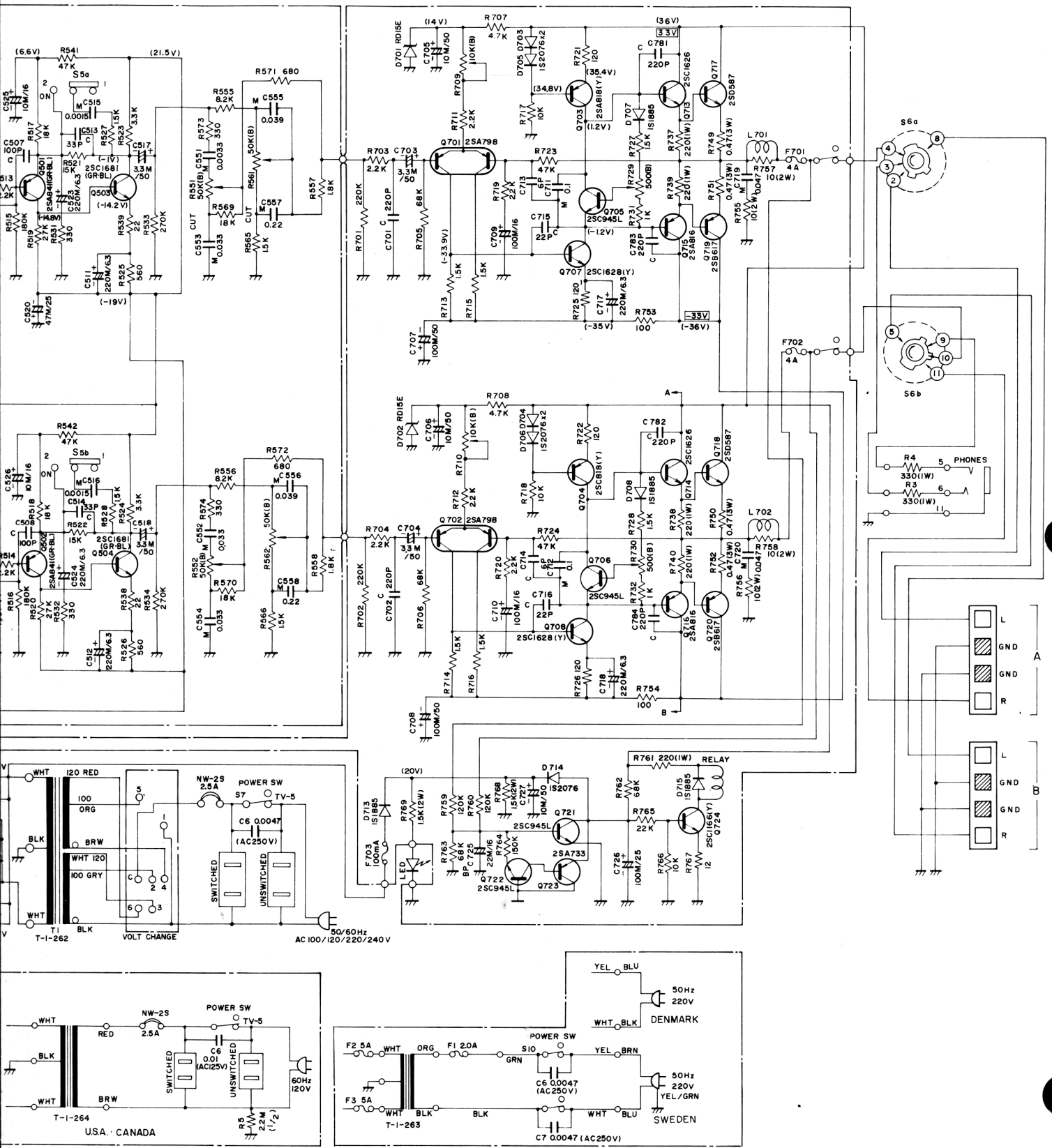

# BLOCK DIAGRAM

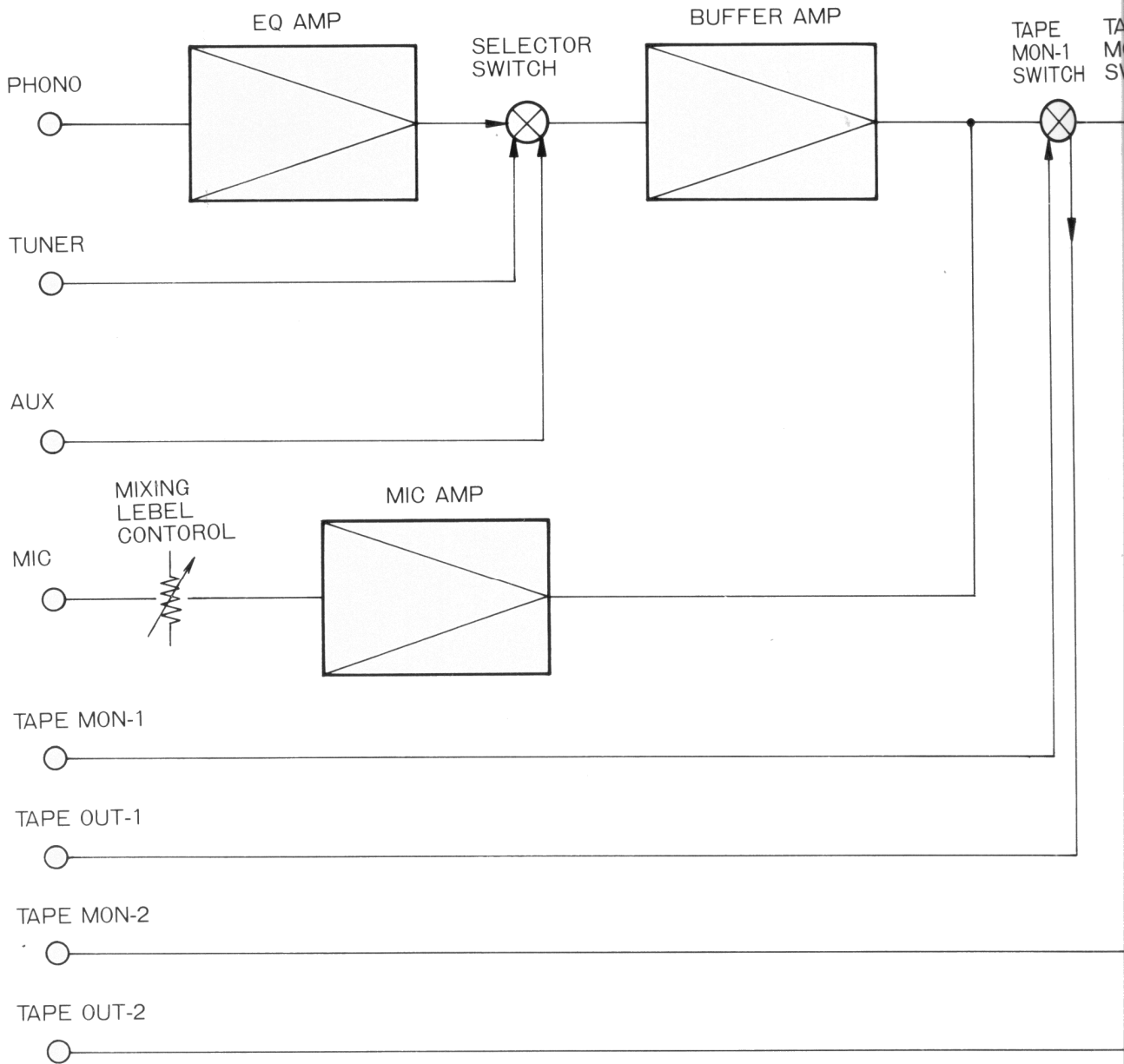

= ONE CHANNEL ONLY =

# GRAM TRM-650

