

# Acer AL2216W Service Guide

Service guide files and updates are available on the CSD web: for more information, Please refer to <http://csd.acer.com.tw>

## Copyright

Copyright © 2003 by Acer Incorporated. All rights reserved. No part of this publication may be reproduced, transmitted, transcribed, stored in a retrieval system, or translated into any language or computer language, in any form or by any means, electronic, mechanical, magnetic, optical, chemical, manual or otherwise, without the prior written permission of Acer Incorporated.

## Disclaimer

The information in this guide is subject to change without notice. Acer Incorporated makes no representations or warranties, either expresses or implied, with respect to the contents hereof and specifically disclaims any warranties of merchantability or fitness for any particular purpose. Any Acer Incorporated software described in this manual is sold or licensed "as is". Should the programs prove defective following their purchase, the buyer (and not Acer Incorporated, its distributor, or its dealer) assumes the entire cost of all necessary servicing, repair, and any incidental or consequential damages resulting from any defect in the software.

Acer is a registered trademark of Acer Corporation.

Intel is a registered trademark of Intel Corporation.

Pentium and Pentium II/III are trademarks of Intel Corporation.

Other brand and product names are trademarks and/or registered trademarks of their respective holders.

## Conventions

The following conventions are used in this manual:

<b>Screen messages</b>	Denotes actual messages that appear on screen
<b>Note</b>	Gives bits and pieces of additional information related to the current topic.
<b>Warning</b>	Alerts you to any damage that might result from doing or not doing specific actions.
<b>Caution</b>	Gives precautionary measures to avoid possible hardware or software problems.
<b>Important</b>	Reminds you to do specific actions relevant to the accomplishment of procedures.

## Preface

Before using this information and the product it supports, please read the following general information.

1. this Service Guide provides you with all technical information relating to the BASICCONFIGURATION decided for Acer's "global" product offering. To better fit local market requirements and enhance product competitiveness, your regional office MAY have decided to extend the functionality of a machine (e.g. add-on card, modem, or extra memory capability). These LOCALIZED FEATURES will NOT be covered in this generic service guide. In such cases, please contact your regional offices or the responsible personnel/channel to provide you with further technical details.
2. please not WHEN ORDERING FRU PARTS, that you should check the most up-to-date information available on your regional web or channel. If, for whatever reason, a part number change is made, it will not be noted in the printed Service Guide, for ACER-AUTHORIZED SERVICE PROVIDERS, your Acer office may have a DIFFERENT part number code to those given in the FRU list of this printed Service Guide. You MUST use the list provided by your regional Acer office to order FRU parts for repair and Service of customer machines.

## **WARNING: (FOR FCC CERTIFIED MODELS)**

**NOTE:** this equipment has been tested and found to comply with the limits for a Class B digital device, pursuant to Part 15 of the FCC Rules. These limits are designed to provide reasonable protection against harmful interference in a residential installation. This equipment generates, uses and can radiate radio frequency energy, and if not installed and used in accordance with the instructions, may cause harmful interference to radio communications. However, there is no guarantee that interference will not occur in a particular installation. If this equipment does cause harmful interference to radio or television reception, Which can be determined by turning the equipment off and on, the user is encouraged to try to correct the interference by one or more of the following measures:

1. Reorient or relocate the receiving antenna.
2. Increase the separation between the equipment and receiver.
3. Connect the equipment into an outlet on a circuit different from that to which the receiver is connected.
4. Consult the dealer or an experienced radio/TV technician for help.

## **WARNING**

Use only shielded signal cables to connect I/O devices to this equipment. You are cautioned that changes or modifications not expressly approved by the party responsible for compliance could void your authority to operate the equipment.

As an ENERGY STAR® Partner our company has determined that this product meets the ENERGY STAR® guidelines for energy efficiency.

## **WARNING:**

To prevent fire or shock hazard, do not expose the monitor to rain or moisture. Dangerously high voltages are present inside the monitor. Do not open the cabinet. Refer servicing to qualified personnel only.

## PRECAUTIONS

- Do not use the monitor near water, e.g. near a bathtub, washbowl, kitchen sink, laundry tub, Swimming pool or in a wet basement.
- Do not place the monitor on an unstable trolley, stand, or table. If the monitor falls, it can injure a person and cause serious damage to the appliance. Use only a trolley or stand recommended by the manufacture or sold with the monitor. If you mount the monitor on a wall or shelf, use a mounting kit approved by the manufacture and follow the kit instructions.
- Slots and openings in the back and bottom of the cabinet area provided for ventilation. To ensure reliable operation of the monitor and to protect it from overheating, be sure these openings are not blocked or covered. Do not place the monitor on a bed, sofa, rug or similar surface. Do not place the monitor near or over a radiator or heat register. Do not place the monitor in a bookcase or cabinet unless proper ventilation is provided.
- The monitor should be operated only from the type of power source indicated on the label. If you are not sure of the type of power supplied to your home, consult your dealer or local power company.
- The monitor is equipped with a three-pronged grounded plug, a plug with a third (grounding) pin. This plug will fit only into a grounded power outlet as a safety feature. If your outlet does not accommodate the three-wire plug, have an electrician install the correct outlet, or use an adapter to ground the appliance safely. Do not defeat the safety purpose of the grounded plug.
- Unplug the unit during a lightning storm or when it will not be used for long periods of time. This will protect the monitor from damage due to power surges.
- Do not overload power strips and extension cords. Overloading can result in fire or electric shock.
- Never push any object into the slot on the monitor cabinet. It could short circuit parts causing a fire or electric shock. Never spill liquids on the monitor.
- Do not attempt to service the monitor yourself; opening or removing covers can expose you to dangerous voltages and other hazards. Please refer all servicing to qualified service personnel.
- To ensure satisfactory operation, use the monitor only with UL listed computers which have appropriate configured receptacles marked between 100-240V AC, Min. 3.5A.
- The wall socket shall be installed near the equipment and shall be easily accessible.
- For use only with the attached power adapter (output 12V DC) which have UL,CSA listed license

## SPECIAL NOTES ON LCD MONITORS

The following symptoms are normal with LCD monitor and do not indicate a problem.

### NOTES

- Due to the nature of the fluorescent light, the screen may flicker during initial use. Turn off the Power Switch and then turn it on again to make sure the flicker disappears.
- You may find slightly uneven brightness in the screen depending on the desktop pattern you use.
- The LCD screen has effective pixels of 99.99% or more. It may include blemishes of 0.01% or less such as a missing pixel or a pixel lit all of the time.
- Due to the nature of the LCD screen, an afterimage of the previous screen may remain after switching the image, when the same image is displayed for hours. In this case, the screen is recovered slowly by changing the image or turning off the Power Switch for hours.

# Table of Contents

Chapter 1 Monitor Features.....	8
1.1 Test Conditions.....	8
1.2 Features.....	8
1.3 LCD Panel Specification.....	9
Chapter 2 OPERATING INSTRUCTIONS.....	13
2.1 Function Name.....	13
2.2 OSD Menu Description.....	15
2.3 OSD Control.....	16
2.4 OSD Menu Screen.....	16
2.5 OSD Function Definition .....	17
2.6 Plug and Play.....	18
2.7 Power Saver.....	18
Chapter 3 Machine Disassembly and Assembly.....	19
3.1 Machine Disassembly.....	19
3.2 Machine Assembly.....	23
Chapter 4 Troubleshooting.....	27
4.1 Abnormal display Troubleshooting.....	27
4.2 Abnormal (On/Off, LCD Display, K/B) Troubleshooting...29	
4.3 Abnormal (BIOS, OSD, Other Display) Troubleshooting. .30	
4.4 Audio Abnormal.....	31
Chapter 5 Connector Information .....	32
5.1 Function Block Diagram.....	32
5.2 Connector Location.....	33
5.3 D-sub Mini 15Pin Connector.....	33
5.4 DC Connector.....	33
Chapter 6 FRU (Field Replaceable Unit).....	34
Chapter 7 Schematic Diagram.....	38

### 1.1 Test Conditions

Item	Condition
Temperature	Normal room temperature (25±2 )
Humidity	50±10%
AC input voltage	100V±2V, 120±2V, 60Hz / 240±2V, 50Hz
Brightness	Maximum with OSD setting
Contrast	Middle with OSD setting
Resolution setting	1680 x 1050 @60HZ
Color temperature	With OSD setting. (For TCO03 CCT test condition requirement, the brightness setting on OSD shall be adjusted to meet 125 nit.)
Measuring instrument	Minolta CS-1000T Spectrometer and Photometer CA-210 or equivalent
Others	Before measuring, "Auto Adjust" & "Auto Balance" must be done in advance

### 1.2 Features

- 22" wide WSXGA+ TFT LCD Panel
- TN Mode Liquid Crystal
- D-SUB/ DVI-D Input
- Audio Function (Optional)
- Support to 75Hz Refresh Rate
- Support VESA-DCC 2B plug & play function
- Support VESA-DPMS & DVI DMPM Power Management Function
- Super Wide Viewing Angle
- High Brightness & Contrast Ratio
- High Brightness & Contrast Angular Dependent
- Fast LC Response Time
- Light Weight



## 1.3 LCD panel Specification

### Technical Specification

	Item	Specification	Unit
LCD panel	Active Area	473.76 (H) x 296.1 (V) (22" wide diagonal)	mm
	Driver Element	a-si TFT Active Matrix	-
	Pixel Number	1680 x R.G.B. x 1050	pixel
	Pixel Pitch	0.282 (H) x 0.282 (V)	mm
	Pixel Arrangement	RGB Vertical Stripe	-
	Display Color	16.2M	color
	Transmissive Mode	Normally White	-
	Viewing Angle (H / V)	Typical 170 / 160	degree
	Brightness	Typical 300	cd/m <sup>2</sup>
	Contrast Ratio	Typical 700	-
	LC Response Time (Tr+Tf)	5 (Tr: 2 + Tf: 3)	msec
	Graphic	Separate Sync.	TTL Level
Horizontal Sync.		Positive / Negative	-
Vertical Sync.		Positive / Negative	-
Input Connector		D-Sub mini 15 pins, DVI-D 24 pins	-
Performance	Auto Adjust	Clock, Phase, H Position & V Position	-
	Screen Scaling	VGA/SVGA/XGA/SXGA Full Screen Display	-
	Power Management	VESA DPMS, DVI DMPM, ENERGY STAR <sup>®</sup> Compliance	-
	Color Adjustment	User, 6500K, 7500K & 9300K	-
	OSD Language	English, French, German, Spanish, Italian, Japanese, Traditional Chinese, Simplified Chinese, Russian, Korean	-
Power source	Supplier (Model No.)	DELTA /DAC-19xxx	
	Power Input	AC100~240 (Worldwide)	V
	Input frequency	50 ~ 60	Hz
	Input Current	1600 (max)	mA
	Efficiency	AC input 100V <sub>AC</sub> 80% (min)	
	Inrush Current (Cold Start at 25 °C, Full Load)	120 Max./ 240V <sub>AC</sub> / 50Hz	A
Power consumption	Operation Mode	< 48W (typ.)	W
	Power Saving Sleep Mode	< 2W @230VAC 50Hz	W
	Power Saving OFF Mode	< 1W @230VAC 50Hz	W
Tilt angle	Upward / Downward	20 / 0	degree
Physical	Dimension, weight	532 x 401.5 x 244 (W x H x T) , 4.5	mm, kg
DDC	Plug & Play	DDC 2B Compliance	-
Function	Function key	6keys	-
	Audio Amplifier Output	2W (max.)	W
	Speaker Rating	N.A.	W

(1) Definition of Viewing Angle ( $\theta_x, \theta_y$ ):

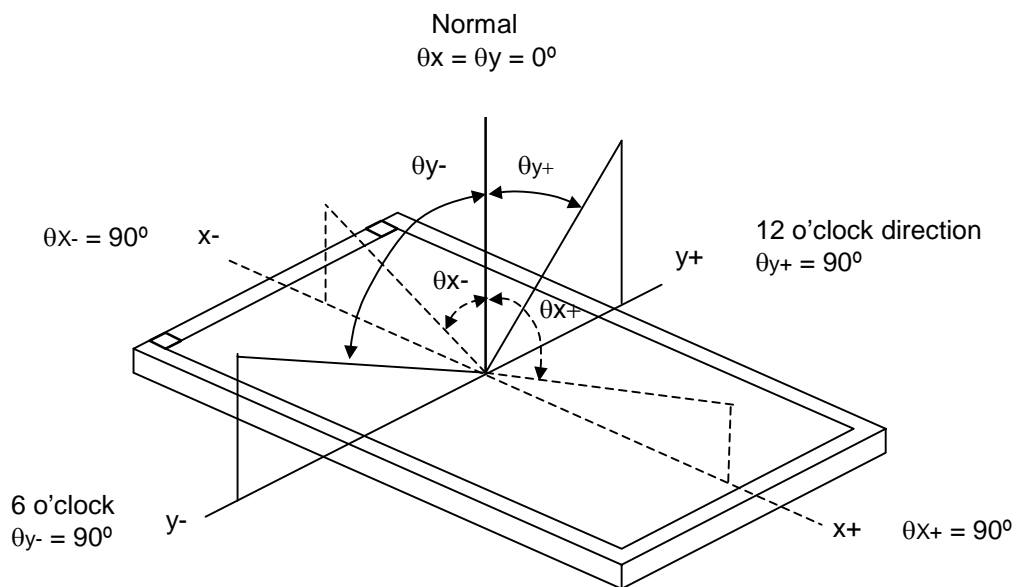
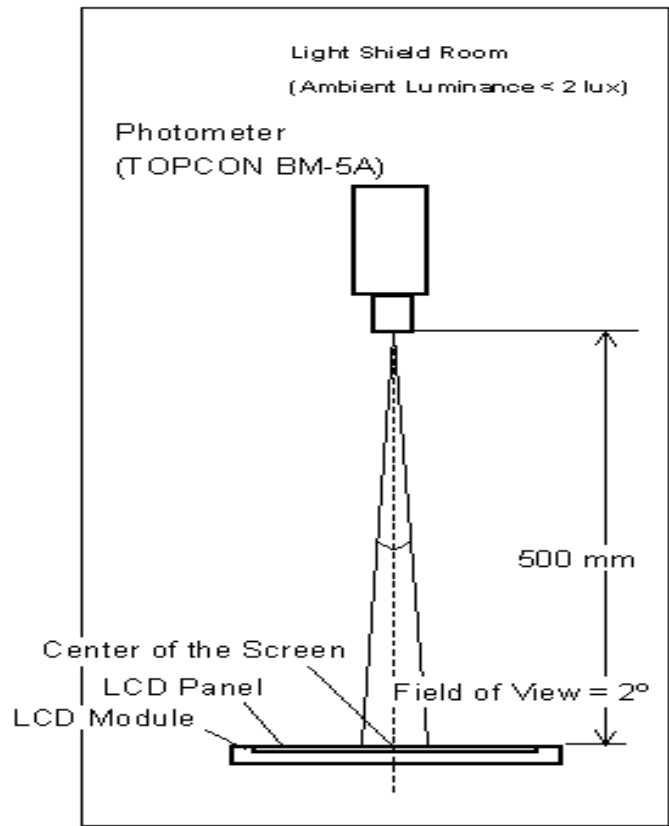

**(2) Definition of Contrast Ratio (CR):**

The contrast ratio can be calculated by the following expression and figure below.

$$\text{Contrast Ratio (CR)} = L_{255} / L_0$$

L255: Luminance of gray level 255

L 0: Luminance of gray level 0

$$\text{CR} = \text{CR} (1)$$

CR (X) is corresponding to the Contrast Ratio of the point X at Figure in Note (5).

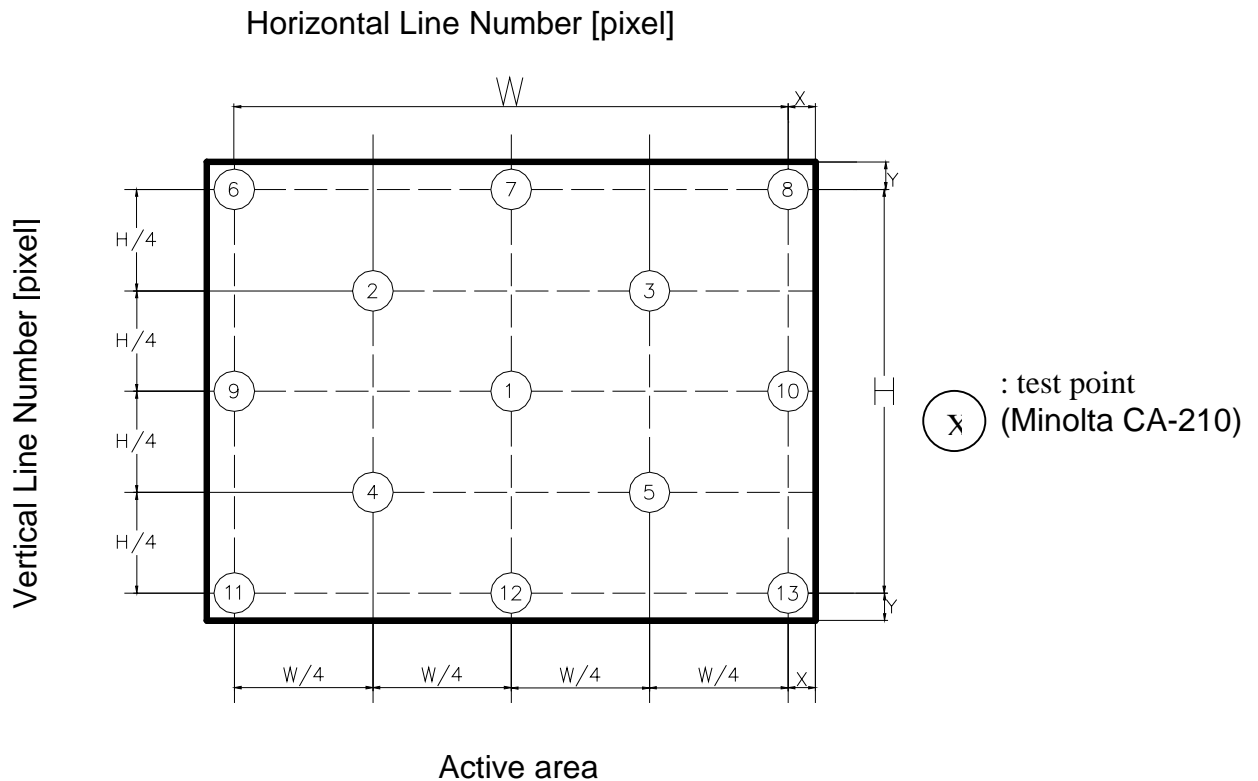

The position of measuring area corner: X=10.0mm ; Y=10.0mm

Luminance of center point: L=L(1)

Brightness Uniformity Measurement points: Thirteen specified points 1-13

Formula: Maximum [L (1), L (2), L (3), L (4), L (5), L (6), L (7), L (8), L (9), L (10), L (11), L (12), L (13)]/Minimum [L (1), L (2), L (3), L (4), L (5), L (6), L (7), L (8), L (9), L (10), L (11), L (12), L (13)]

**(3) Definition of Response Time ( $T_R$ ,  $T_F$ ) and Measurement Method:**

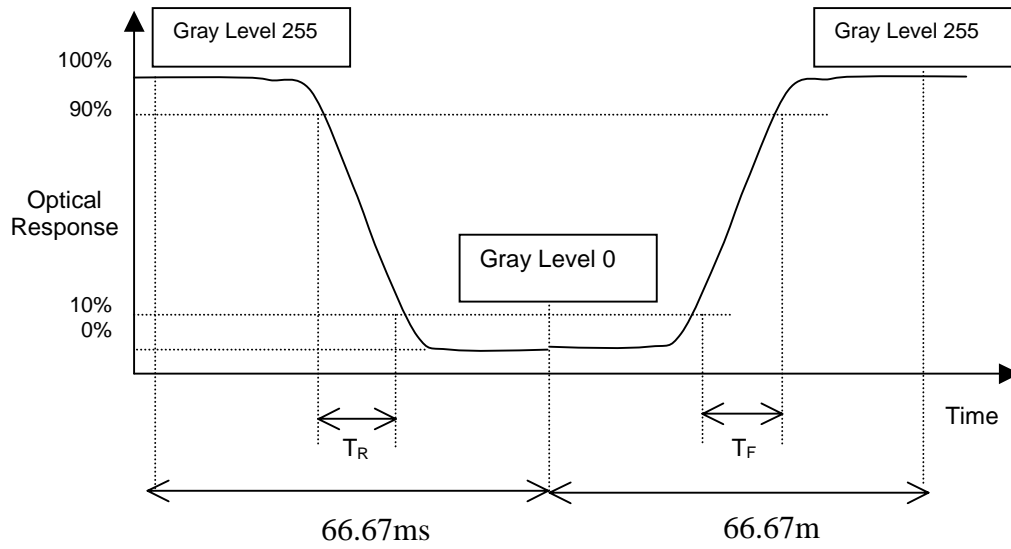

**(4) Luminance, Chromaticity and CCT Measurement**

The LCD module should be stabilized at given temperature for 20 minutes to avoid abrupt temperature change during measuring. In order to stabilize the luminance, the measurement should be executed after lighting Backlight for 20 minutes in a windless room.

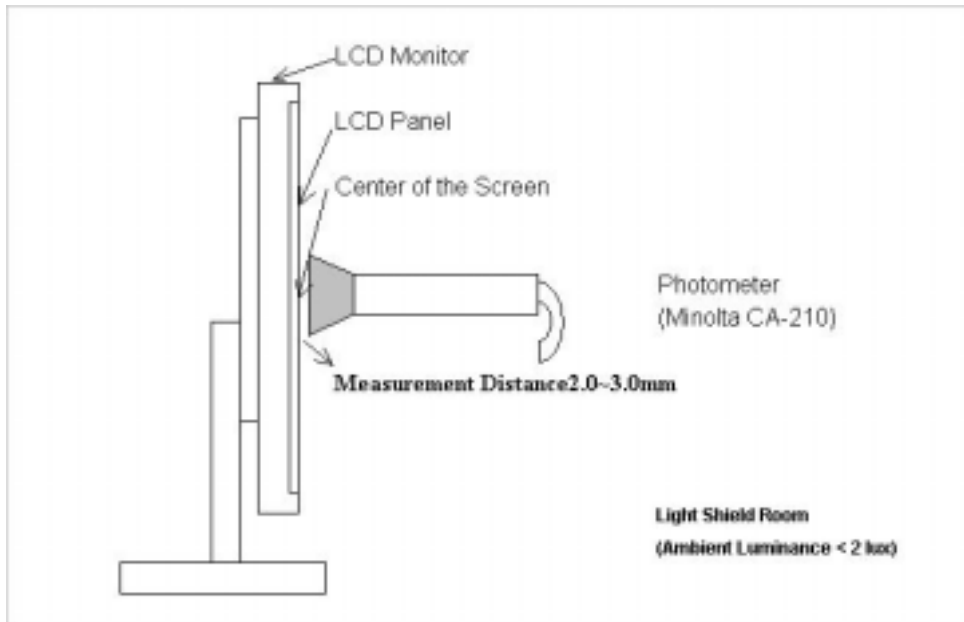

2.1 Function Name

2.1.1 Front

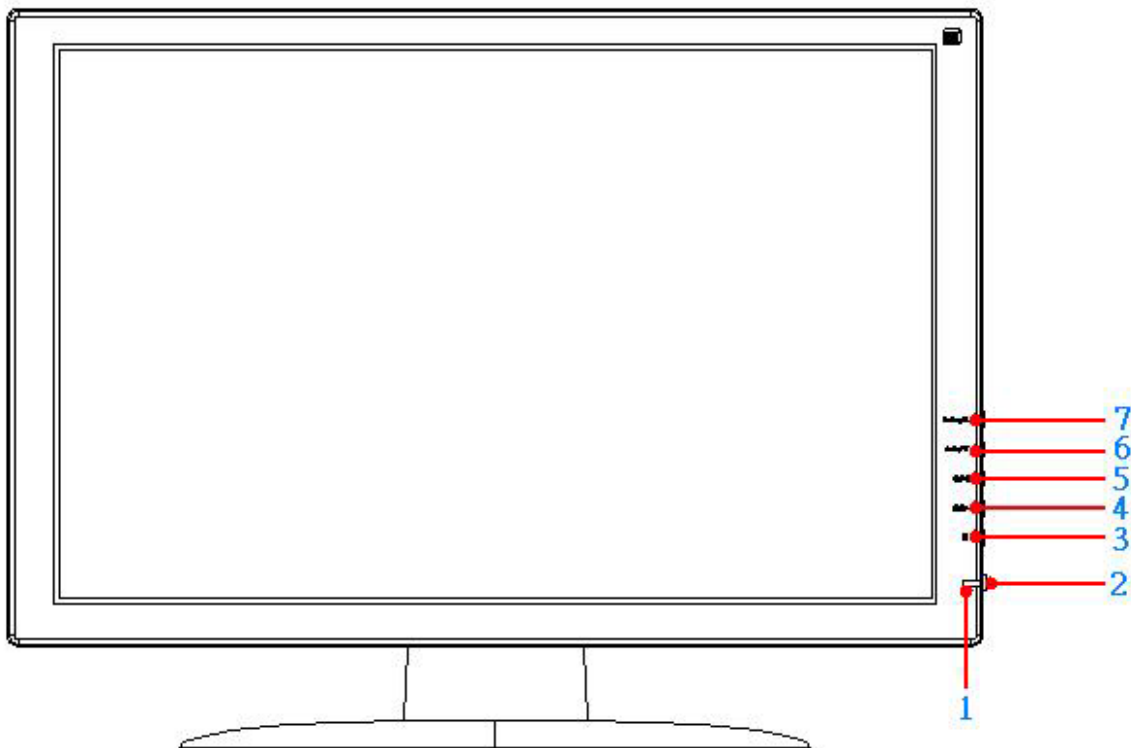

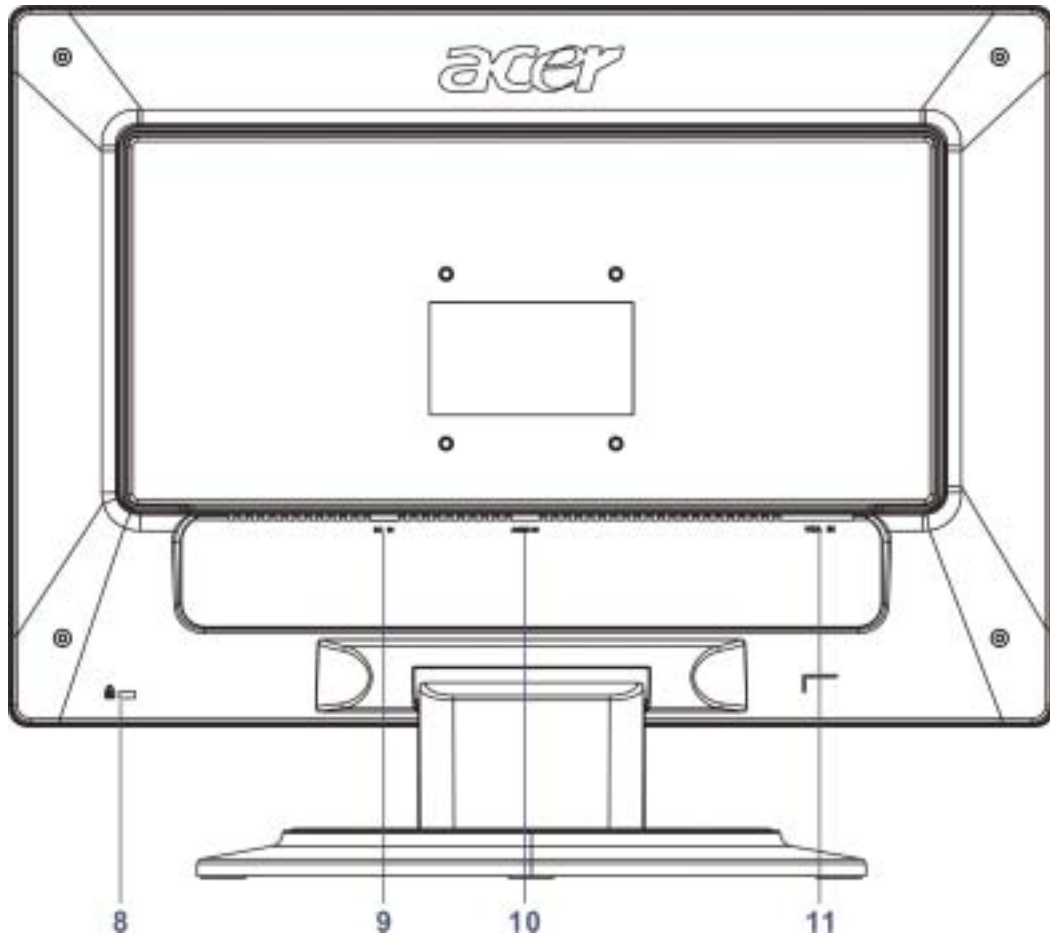

No.	Key		Descriptions
1`	LED Indicator	Green	Normal operation
		Orange	Power Management
2			Power on / Power off
3			OSD control MENU button/Access Main/Sub-menu/Quick Menu Selection
4			+ /QUICK MENU Access (Brightness, Contrast and Volume)
5			- /QUICK MENU Access (Brightness, Contrast and Volume)
6			Adjust Clock, Phase, H Position and V Position automatically / Exit
7			D-Sub, DVI Input Source Selection/Turbo Brightness Switch

### 2.1.2 Back



No.	Name	Descriptions
8	D-Sub	D-sub mini 15pin Connector
9	DVI-D	DVI-D 24pin Connector
10	AC-IN	AC Power Jack
11	Lock hole	Kensington

## 2.2 OSD Menu Description

1. **Power:** Press this key to control power ON/OFF of the Monitor.  
Green: normal display.  
Orange flicker: no signal input.  
Orange: power off.
2. **Auto/Exit:** When the input signal source is PC, used to execute auto adjustment  
>: Press this button for selection or adjustment when OSD is shown.
3. **+/** : Used to select the OSD function; when there is OSD menu, used to increase function value.  
Enter brightness control function directly when there is no OSD menu.
4. **-/**: Used to select the OSD function; when there is OSD menu, used to decrease function value.  
Enter contract control function directly when there is no OSD menu.
6. **Menu:** Use to display OSD menu; when there is OSD menu, used to execute OSD function or enter next layer of OSD menu; if executing OSD function, exit OSD function and save the value adjusted.

### 2.3 OSD Control

1. Click MENU to display the OSD window as shown in the following figure.
2. Click < or > to select the function to be adjusted as shown in the following figure.
3. Click the MENU to select the function to be adjusted.
4. Click < or > to change current settings.
5. To exit OSD, select “EXIT” to close the OSD window and save changes. To change other settings, repeat steps 2-4.



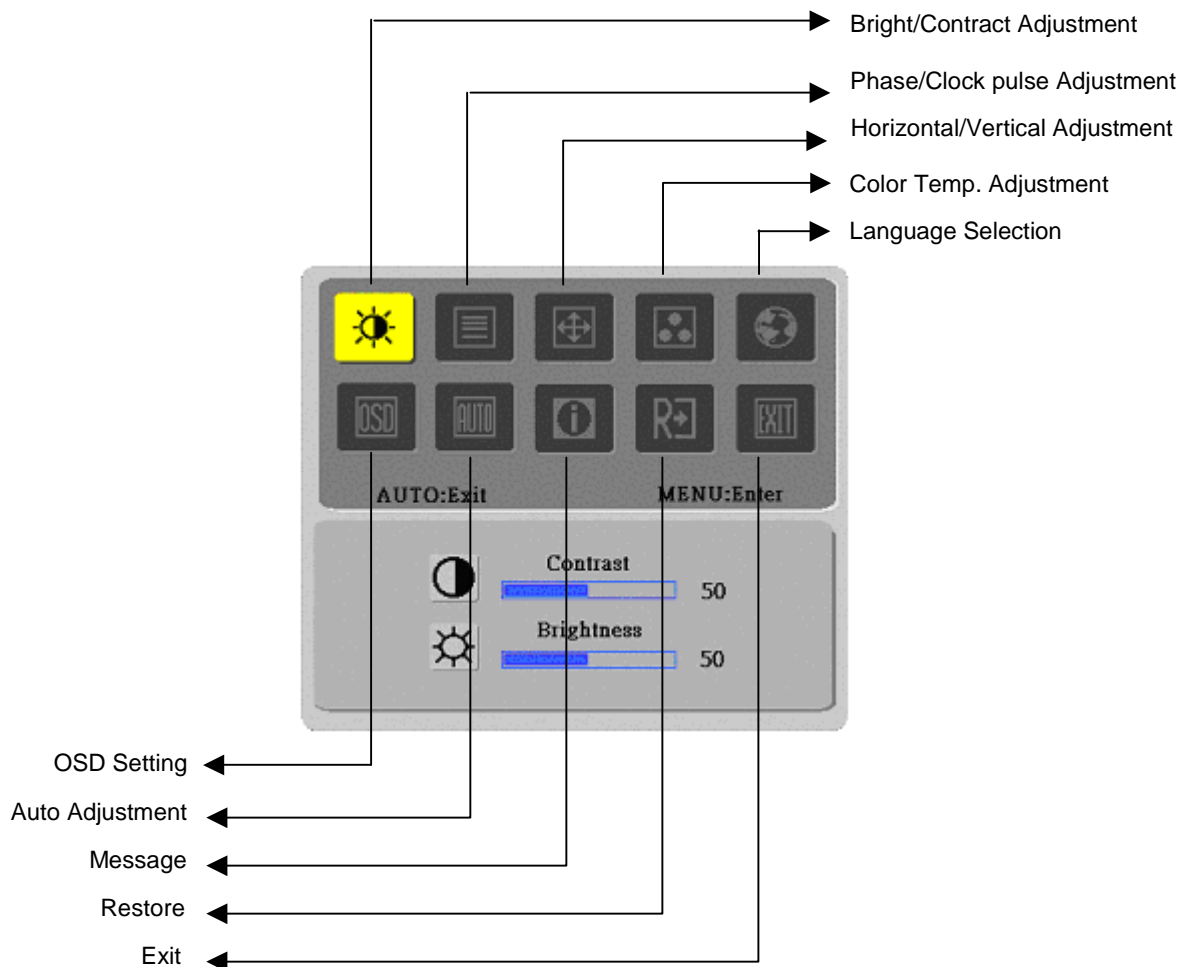



















### 2.4 OSD Menu Screen



- ◆ The OSD disappears several seconds after you stop pressing the buttons while performing an adjustment.
- ◆ Any changes are automatically saved in the memory when the OSD disappears. Turning off the power should be avoided while using the menu.
- ◆ Adjustments for clock, phase and positions are saved for each signal timing. Except for these adjustments, all other adjustments have only one setting, which applies to all signal timings.
- ◆ The color will change from white to pink while the function is selected.



## 2.5 OSD Function Definition

Primary Directory Symbol	Secondary Directory Symbol	Secondary Directory Items	Description
		Contrast	Adjust the contrast between the foreground and background of an image on the screen
		Brightness	Adjust the background brightness of the screen
		Phase	Adjust the focus of the image (for analog input adjustment only)
		Clock Pulse	Adjust the clock pulse of the image (for analog input adjustment only)
		Horizontal	Move the image left and right on the screen (for analog input adjustment only)
		Vertical	Move the image up and down on the screen (for analog input adjustment only)
	N/A	Warm Color Temp.	Set up the color temp. to be warm white color
	N/A	Cold Color Temp.	Set up the color temp. to be cold white color
		User Definition/Red	Adjust red/green/blue gain
		User Definition/Green	
		User Definition/Blue	
	N/A	English	Select the language you want
	N/A	繁體中文	
	N/A	Deutsch	
	N/A	Francis	
	N/A	Espanola	
	N/A	Italian	
	N/A	简体中文	
	N/A	日本語	
		Horizontal	Move OSD left and right
		Vertical	Move OSD up and down
		OSD Time Display	Adjust OSD time display settings
	N/A	Auto Adjustment	Set up horizontal, vertical, sequence and focus automatically (for analog input only)
	N/A	Analog Digital	Select the input source you want (for DVI Input only)
	N/A	Message	Display resolution, H/V frequency and the input port used for current input timing function
	N/A	Restore	Restore to factory settings
	N/A	Exit	Close the OSD window and save changes

## 2.6 Plug and Play

- ◆ The new **VESA Plug and Play** function is used which eliminates the complicated and time-consuming installation process.
- ◆ You can use the **Plug and Play** system without encountering usual installation problems. Your computer system can easily identify and automatically adjust the monitor.
- ◆ The LCD Monitor uses **Display Data Channel (DDC)** to send **Extended Display Identification Data (EDID)** to the computer system, so the computer system can be set to monitor auto adjust.

## 2.7 Power Saver

- ◆ Power control system, also called (**Power Saver**), is installed inside the LCD Monitor.
- ◆ If the monitor has not been used for a certain period of time, the system will turn the monitor to low voltage mode to save power. Slight moving or any click will return to the original image.
- ◆ The VGA card inside the computer handles **Power Saver**. You can use computer software to set the function.
- ◆ The LCD Monitor is compatible with EPA ENERGY STAR and NÜTEK if used with a VESA DPMS computer.
- ◆ To save power, turn off the power of the LCD monitor when not in use.



# MACHINE DISASSEMBLY AND ASSEMBLY







## Chapter 3

### 3.1 Disassembly Procedures



Picture	Description
	Push the hooks and stand bottom away
	Remove Hinge Cover
	Loosen and remove 4 screws to remove Stand Assay
	Completed
	Loose and remove 5 screws.
	Separate Bezel hooks to take Bezel and Rear Cover Apart.
	Lift up Rear Cover

	<p>Completed</p>
	<p>Remove FFC</p>
	<p>Lift up LCD module and remove bezel.</p>
	<p>Completed</p>
	<p>Loose and remove 2 screws</p>
	<p>Remove Cover AD</p>
	<p>Completed</p>
	<p>Loose and remove 2 screws</p>

	<p>Remove 4 pieces of Backlight wires.</p>
	<p>Loose and remove 4 screws</p>
	<p>Loose and remove 2 screws</p>
	<p>Remove the PCBA Cover</p>
	<p>Completed</p>
	<p>Loose and remove 4 screws</p>
	<p>Remove Lips Board</p>
	<p>Completed</p>









	<p>Remove 2 pieces of FFC from AD PCBA and Backlight</p>
	<p>Loose and remove 4 screws</p>
	<p>Remove FFC</p>
	<p>Remove AD PCBA</p>
	<p>Completed</p>
	<p>Separate OSD PCBA.</p>
	<p>Take OSD PCBA apart</p>

### 3.2 Assembly Procedures

	Place OSD PCBA.
	Push OSD PCBA
	Place LCD module
	Insert new AD PCBA
	Insert a piece of FFC to AD PCBA
	Fasten 4 fixed screws of AD PCBA
	Insert 2 pieces of FFC to AD PCBA and Backlight

	<p>Completed</p>
	<p>Insert new Lips Board</p>
	<p>Fasten 4 fixed screws of Lips Board</p>
	<p>Completed</p>
	<p>Join the PCBA Cover</p>
	<p>Fasten 2 screws</p>
	<p>Fasten 4 screws</p>
	<p>Insert 4 pieces of Backlight wires.</p>



	<p>Fasten 2 screws</p>
	<p>Completed</p>
	<p>Join hooks of Cover AD with Bezel</p>
	<p>Fasten 2 screws</p>
	<p>Completed</p>
	<p>Place LCD module to LCD Bezel.</p>
	<p>Insert a piece of FFC to OSD Board</p>
	<p>Completed</p>

	<p>Join hooks of Rear Cover with Bezel</p>
	<p>Fasten 5 screws</p>
	<p>Completed</p>
	<p>Place Stand Assy and fasten 4 screws</p>
	<p>Insert Stand Cover</p>
	<p>Have the hook latched</p>

## 4.1 Abnormal Display Troubleshooting

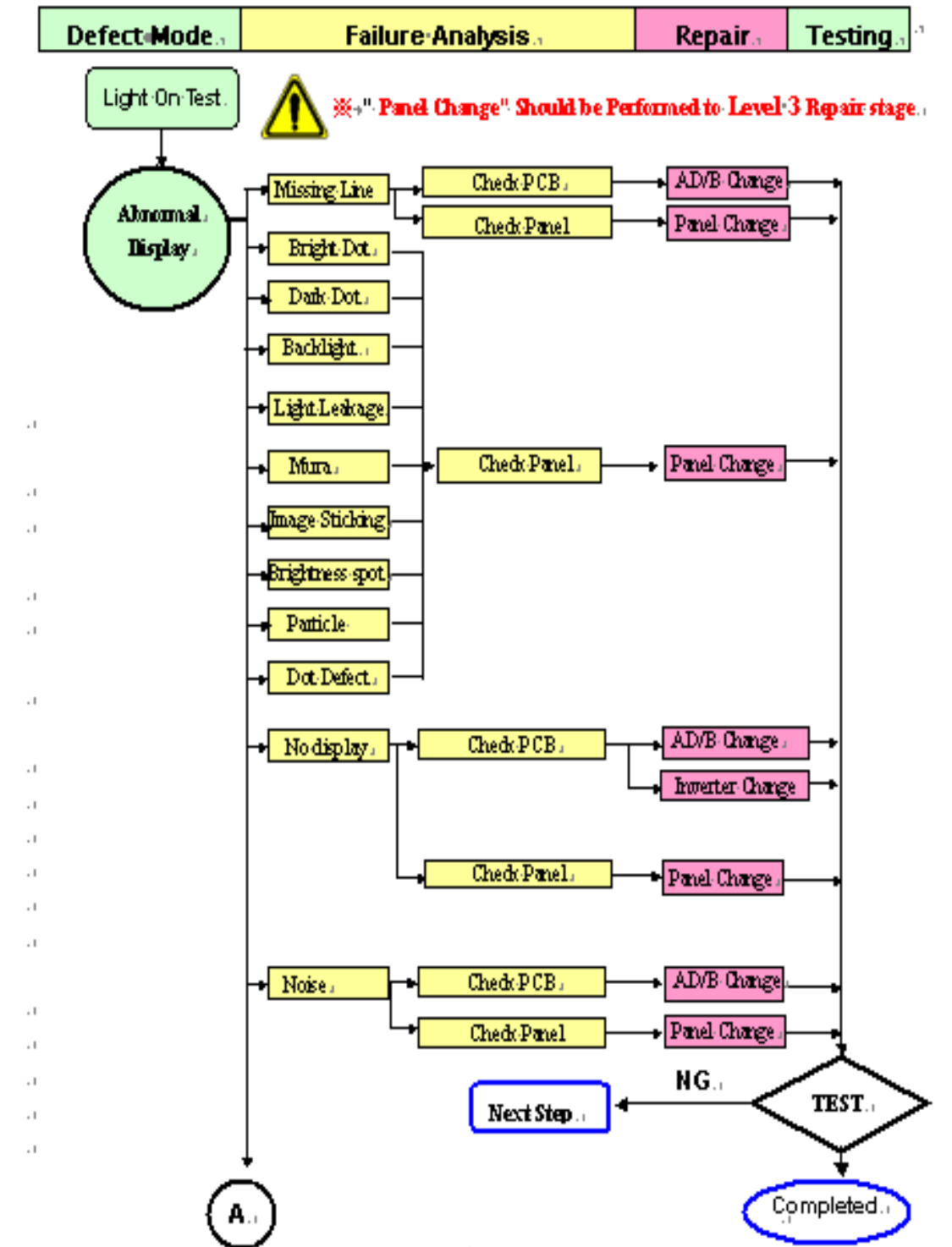

A.



"Panel Change" Should be Performed to Level-3 Repair stage.

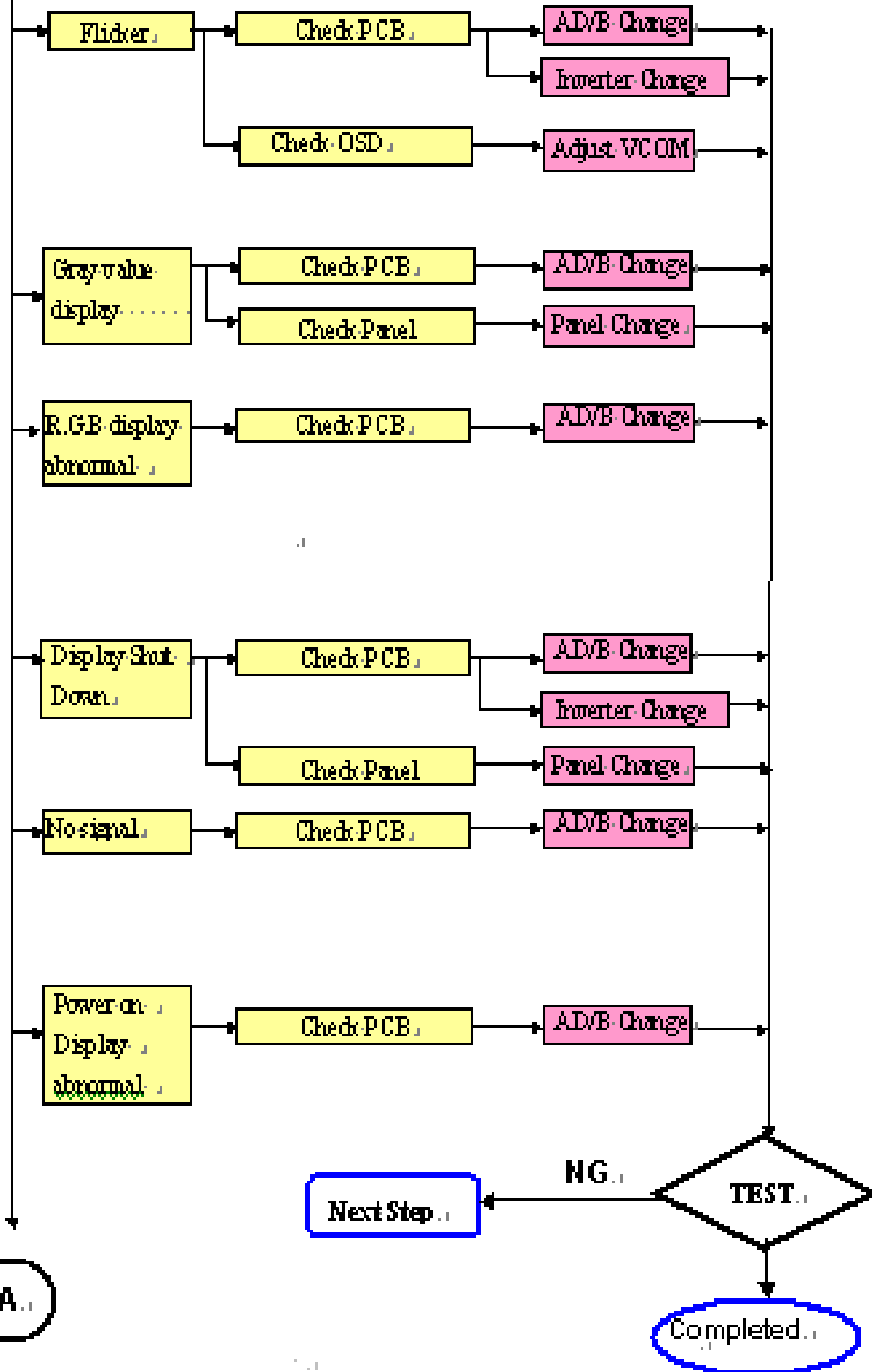

## 4.2 Abnormal (ON/OFF, LCD display, Keyboard) Troubleshooting



※ "Panel Change" should be performed to Level 3 Repair stage.

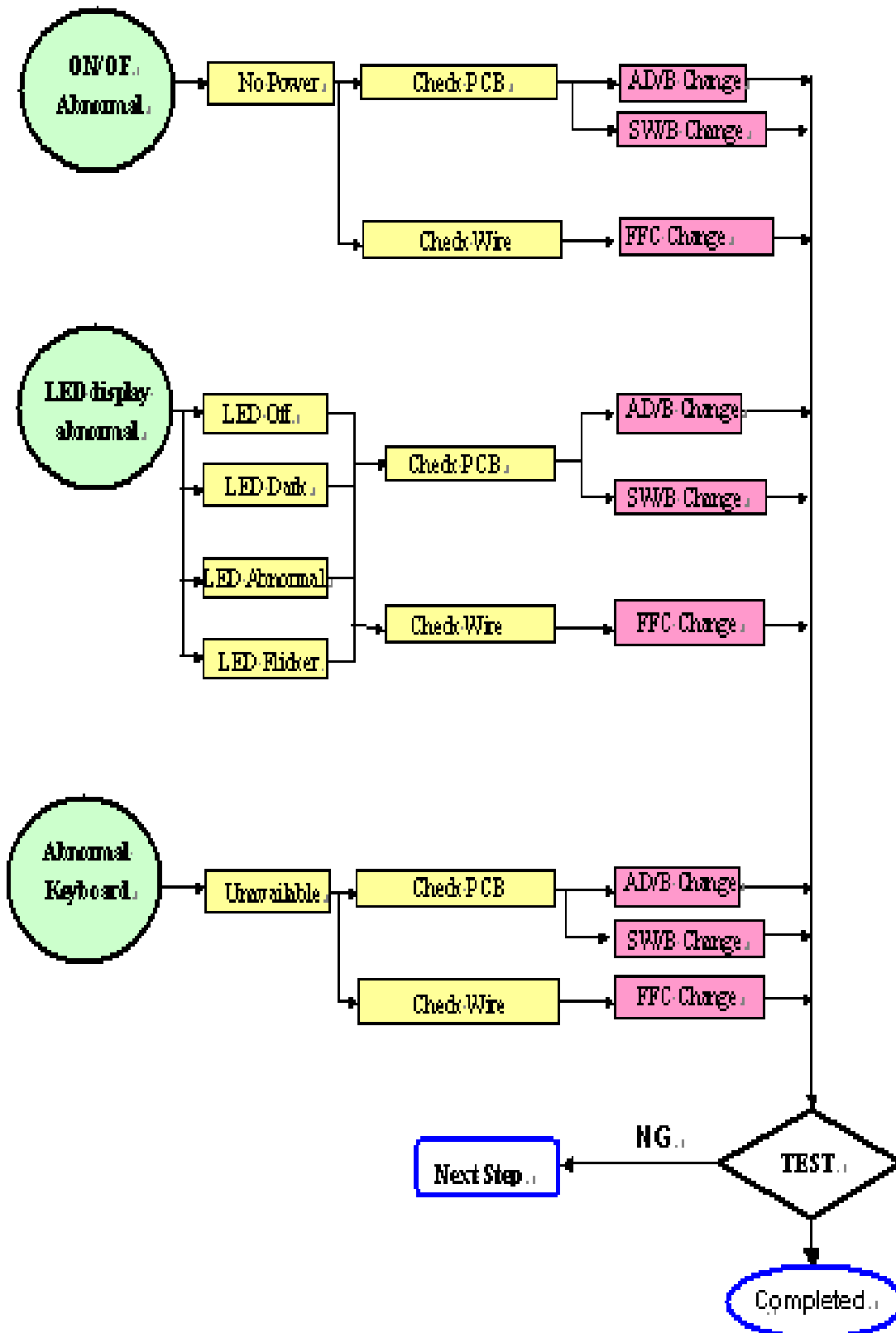

### 4.3 Abnormal (BIOS, OSD, Other Display) Troubleshooting



※ "Panel Change" Should be Performed at Level-3 Repair stage.

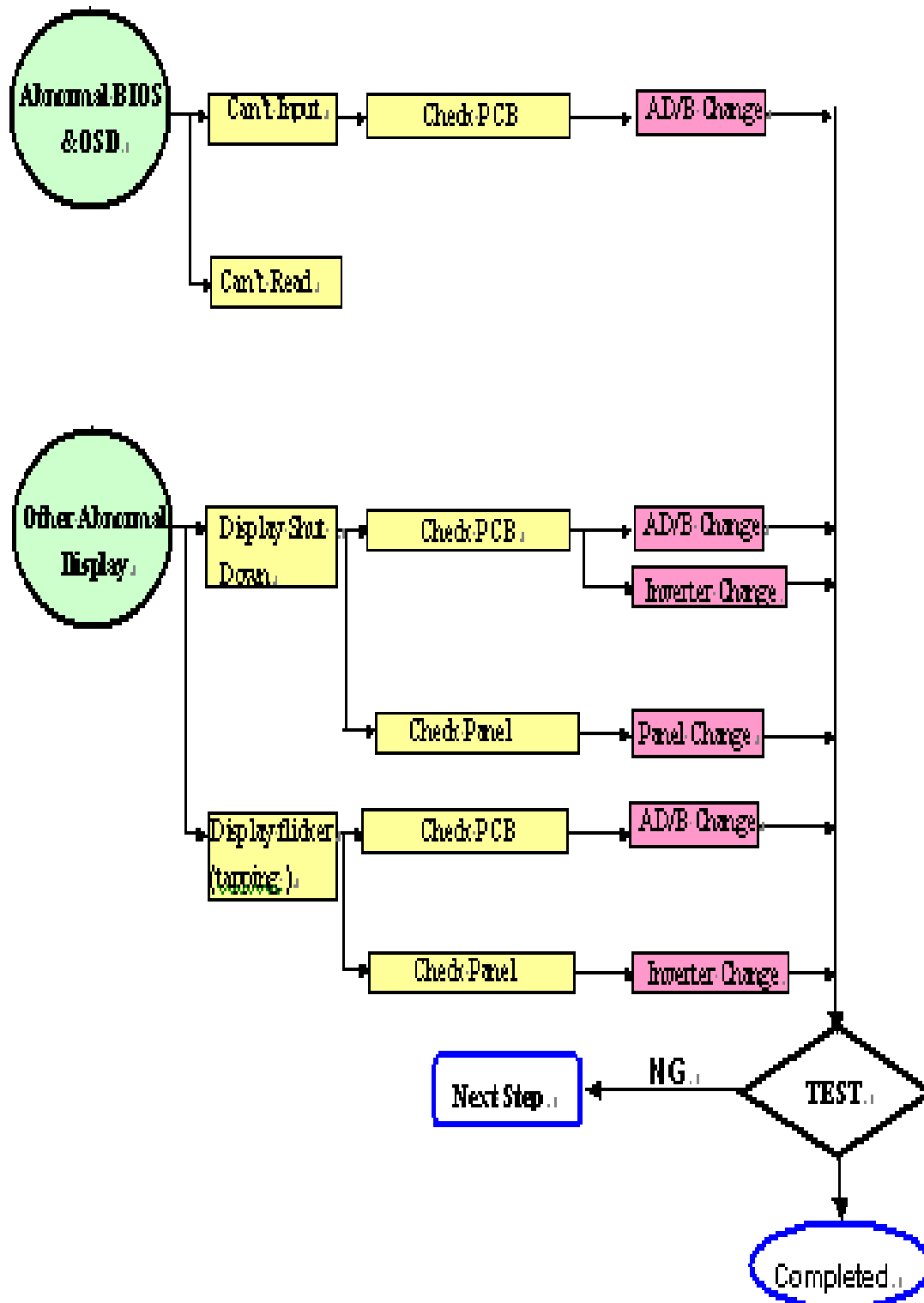



※+ "Panel Change" Should be Performed at Level-3 Repair stage.

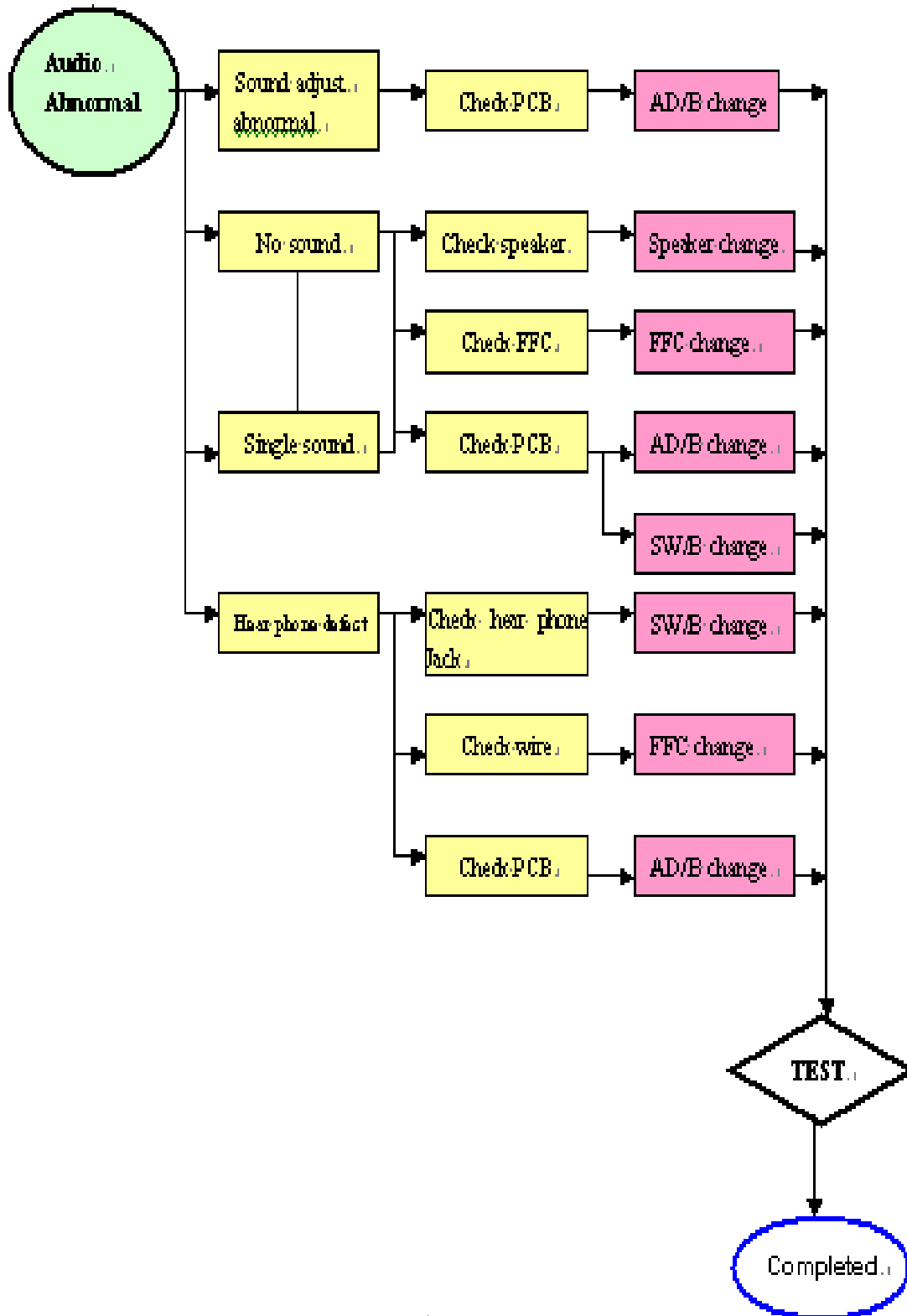

## 5.1 Function Block Diagram

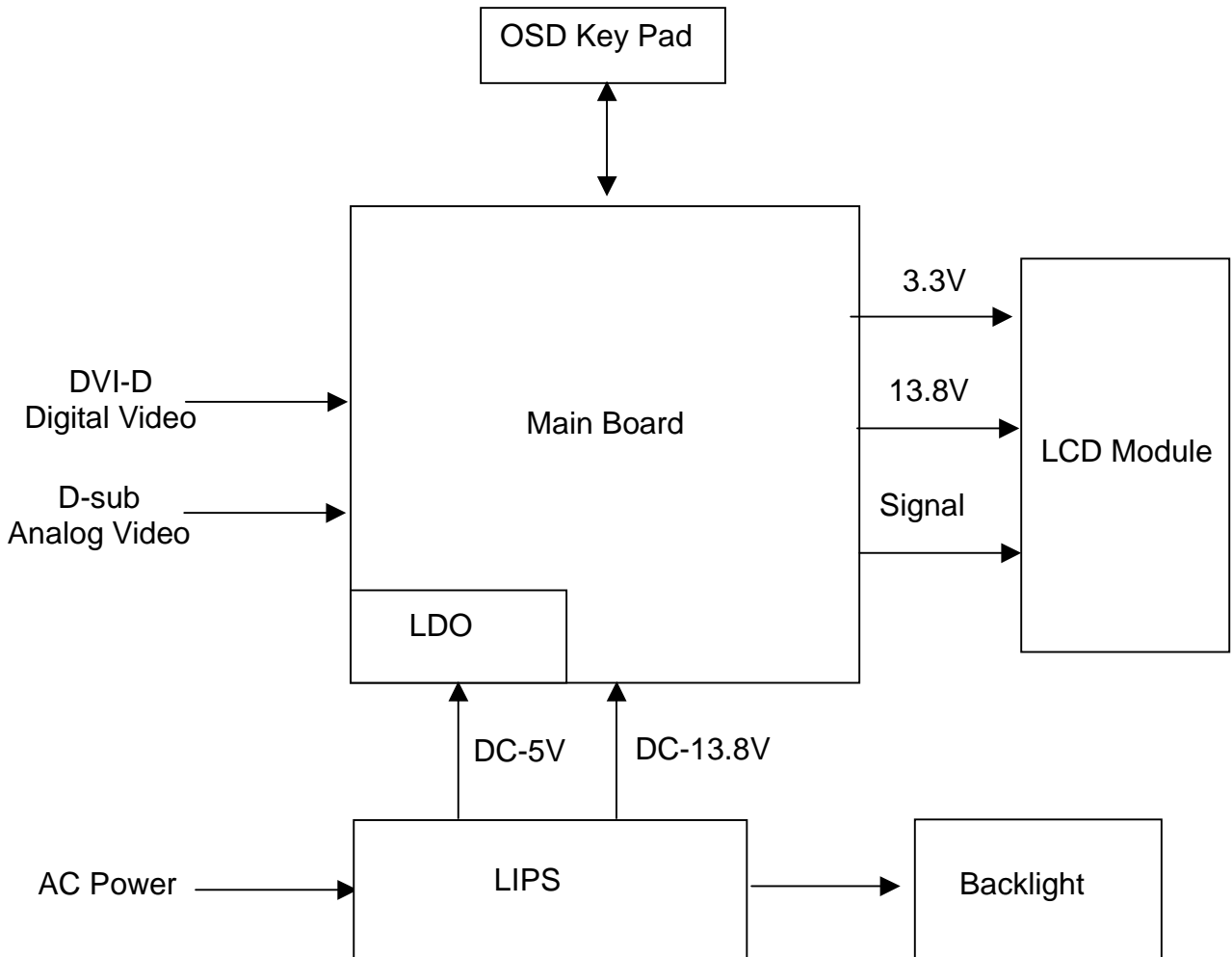



## 5.2 D-sub mini 15pin Connector

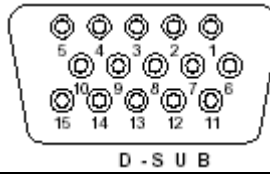

Pin No.	Pin Function	Pin No.	Pin Function
1	Red video input	9	NC
2	Green video input	10	Ground
3	Blue video input	11	No connection
4	NC	12	(SDA)
5	Ground	13	Horizontal sync (Composite sync)
6	Red video ground	14	Vertical sync
7	Green video ground	15	(SCL)
8	Blue video ground		

## 5.3 DC Connector

DC Power Jack, d=3.0mm

## 5.4 Audio Connector

Phone Jack, d=3.5mm

# FRU (Field Replaceable Unit) List

## Chapter 6

### Part List

Picture	Part name	Description	Vendor Part No.
	FUNCTION BUTTON BOARD	PCBA FOR ,A190A2-H,A190A2-H-K2,106-02,REV.01	35-D003068
	Lips	Lips Without Audio, DAC-19M009 BF	27-D008552
	Main Board	PCBA for ,A220Z1-Z01-H,A170E2-E03-H-S6,1101-01,Rev.04	35-D007790
	CABLES	FFC,15 Pins, A220Z1-H02,OSD_FFC	32-D009095
	CABLE	FFC,CFC2128/862P0600 68D,36 Pins	32-D008479
	MONITOR CABLE	Accessory Cable,D-Sub,BLACK	32F3018003

Picture	Part name	Description	Vendor Part No.
	STAND BASE	Stand Assy,A220Z1-H02,	40-D009177
	LCD FRONT BEZEL	Bezel Assy,A220Z1-H02	40-D009188
	LCD BACK COVER	Rear Assy,A220Z1-H02	40-D009181
	LCD STAND NECK	Stand Assy,A220Z1-H02	40-D009177
	Hinge Cover	Cover Hinge Assy,A220Z1-H02	40-D009185
	Support Plate	Support Plate,A220Z1-H02	41-D009178
	Cover AD	Cover AD Assy,A190A2	41-D008025



<b>Item</b>	<b>Parts Name</b>	<b>Q'ty</b>
1	Backlight Unit, A220Z1	1
2	PANEL_ASSY_A220Z1-L01	1
3	Metal Frame Front,M220Z1-L01	1
4	Lips Without Audio	1
5	PCBA for,A220Z1-Z01-T	1
6	FFC,CFC2128/862P060068D,36 Pins	2
7	SCREW,M3,P=0.5mm, L=2.5mm	3
8	SCREW,M3,P=0.5mm, L=4mm	13
9	SCREW,M4 ,P=0.7mm, L=8mm	1
10	FFC,15Pins,A220Z1-H02,OSD	1
11	Cover AD Assy,A190A2	1
12	SCREW,M4 ,P=0.7mm, L=11.8mm	2
13	Support Plate,A220Z1-H02	1
14	Bezel Assy,A220Z1-H02	1
15	PCBA for ,A190A2-H-K2	1
16	Rear Assy,A220Z1-H02	1
17	SCREW_M3*8L_PWH_PHC	4
18	SCREW,M3 ,P=1.27mm, L=8mm	1
19	Stand Assy,A220Z1-H02	1
20	SCREW,M4 ,P=0.7mm, L=15mm	4
21	Cover Hinge Assy,A220Z1-H02	2
22	Seat Assy,A220Z1-H02	1



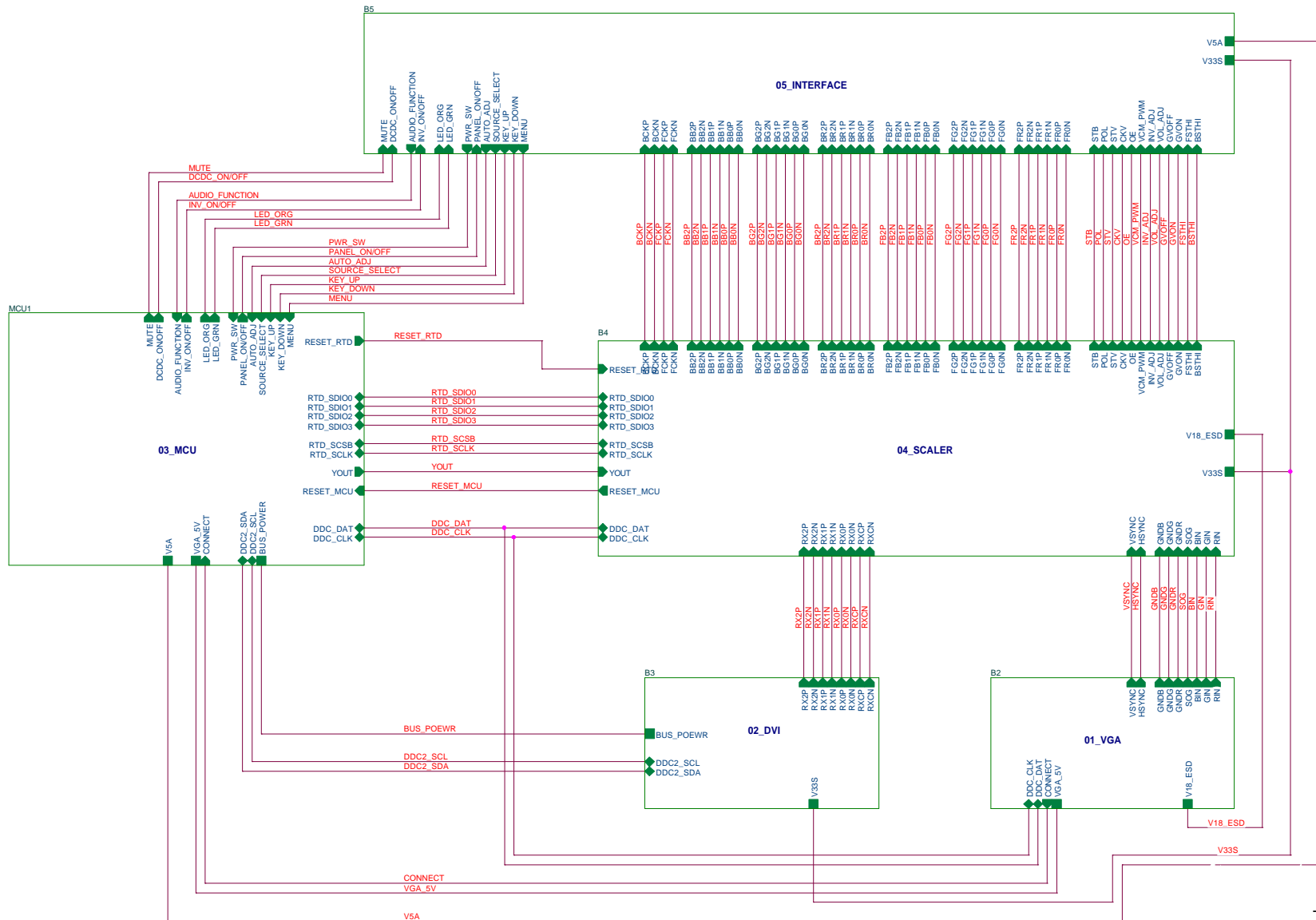

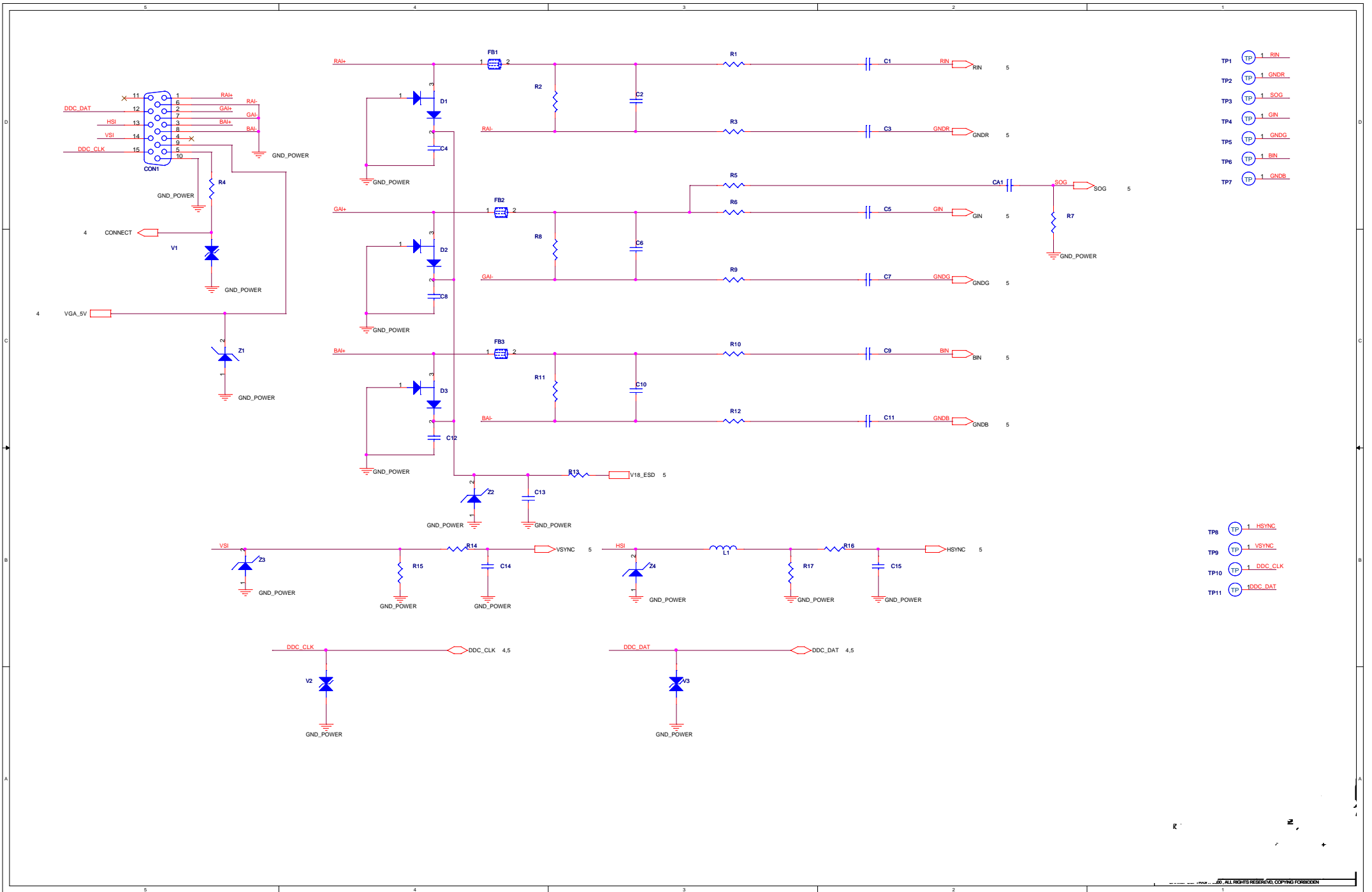

- TP1 (TP -1\_RIN)
- TP2 (TP -1\_GNDR)
- TP3 (TP -1\_GIN)
- TP4 (TP -1\_GNDG)
- TP5 (TP -1\_BIN)
- TP6 (TP -1\_GNDB)
- TP7 (TP -1\_GNDB)

- TP8 (TP 1\_HSYNC)
- TP9 (TP 1\_VSYNC)
- TP10 (TP 1\_DDC\_CLK)
- TP11 (TP 1\_DDC\_DAT)



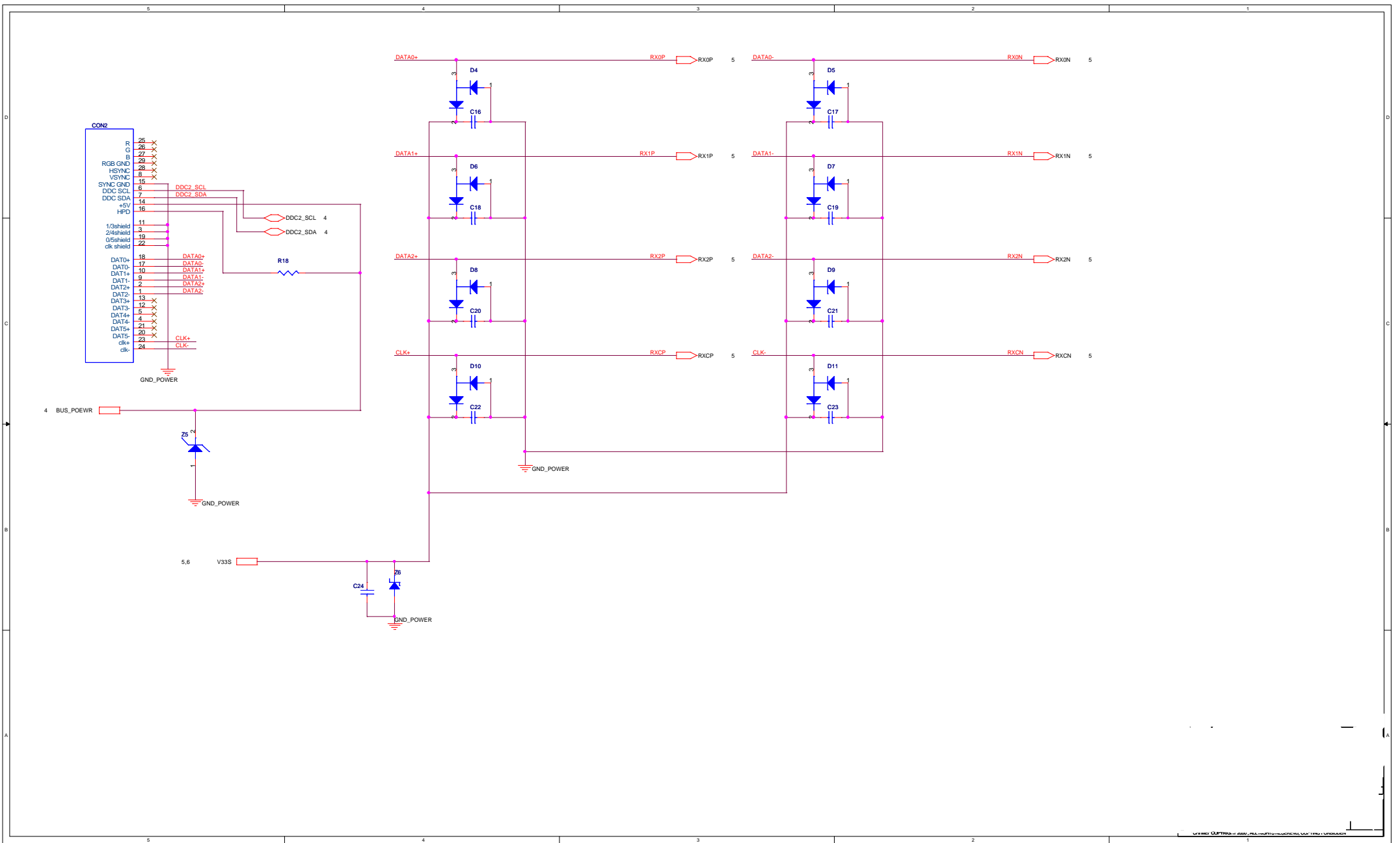

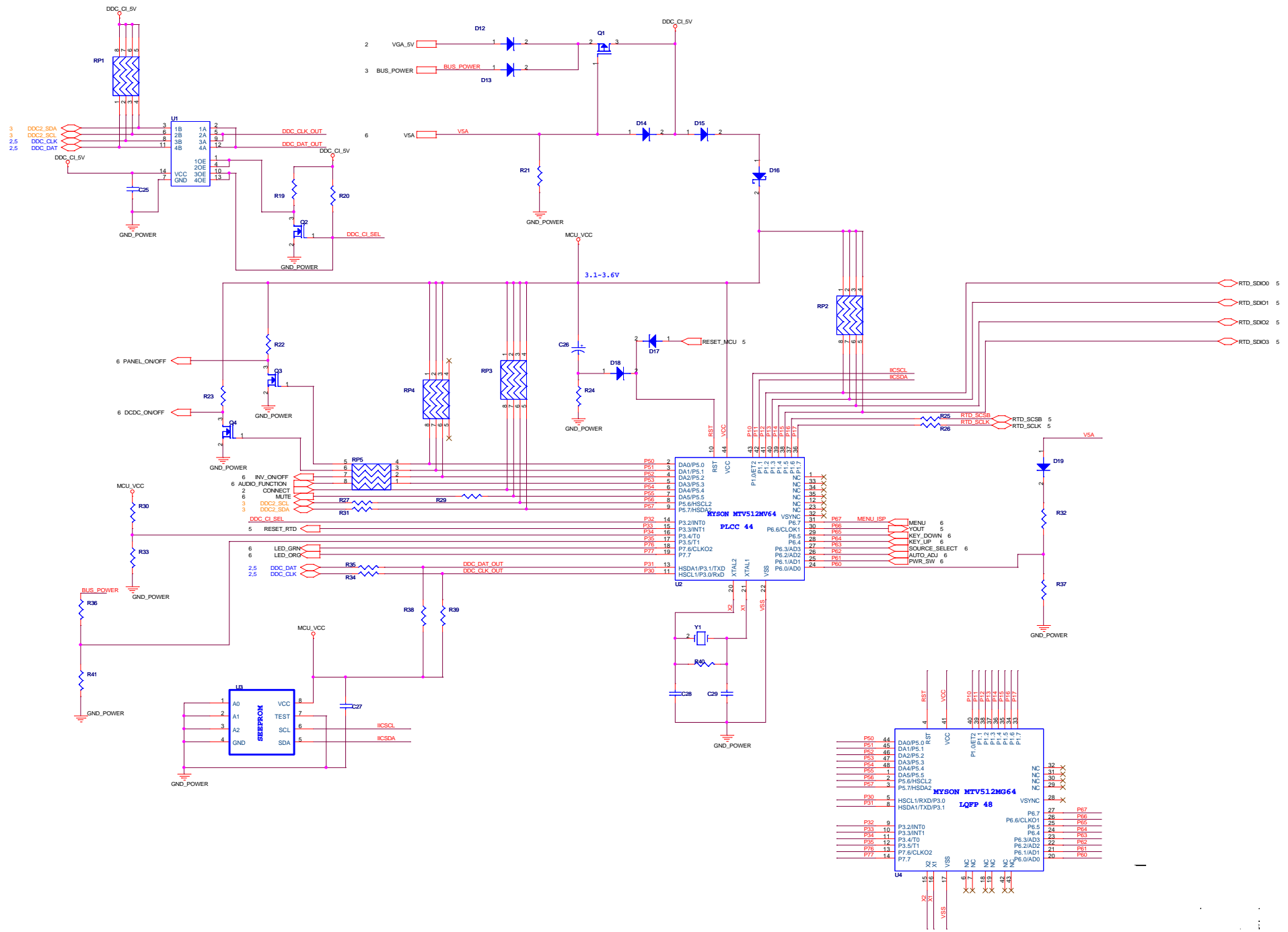

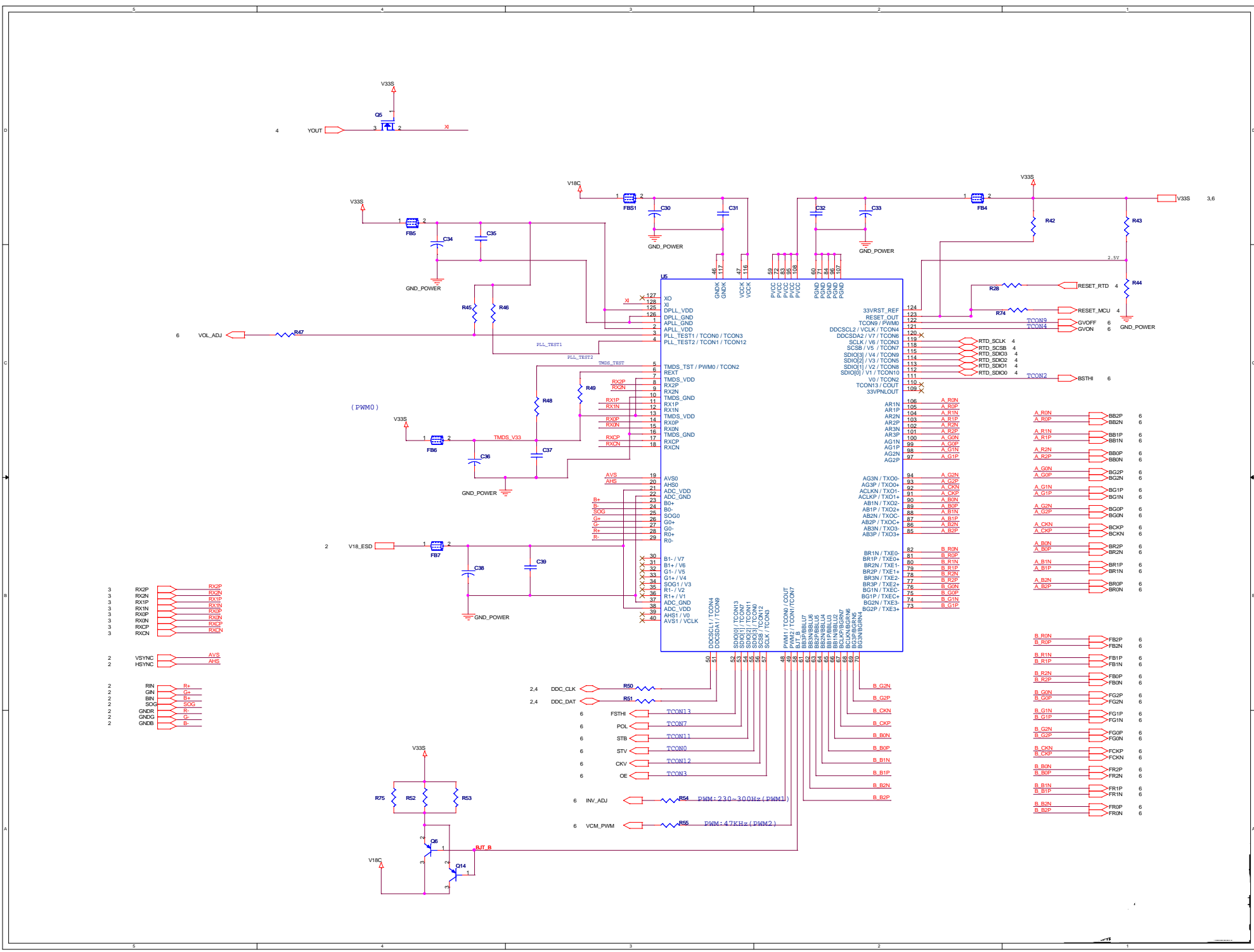

- 3 RX2P RX2P
- 3 RX2N RX2N
- 3 RX1P RX1P
- 3 RX1N RX1N
- 3 RX0P RX0P
- 3 RX0N RX0N
- 3 RXCP RXCP
- 3 RXCN RXCN
  
- 2 VSYNC AVS
- 2 HSYNC AHS
  
- 2 RIN R+
- 2 GIN G+
- 2 BIN B+
- 2 SOG SOG
- 2 GNR G-
- 2 GNDG G-
- 2 GNDG B-

- 2.4 DDC\_CLK R50
- 2.4 DDC\_DAT R51
- 6 FSTH TCON13
- 6 POL TCON7
- 6 STB TCON11
- 6 STV TCON0
- 6 CKV TCON12
- 6 OE TCON3
- 6 INV\_ADJ R54 PWM: 230~300Hz (PWM1)
- 6 VCM\_PWM R55 PWM: 47KHz (PWM2)

- A RON BB2P
- A ROP BB2N
- A R1N BB1P
- A R1P BB1N
- A RON BB0P
- A ROP BB0N
- A G2N BG2P
- A G2P BG2N
- A G1N BG1P
- A G1P BG1N
- A G2N BG0P
- A G2P BG0N
- A CKN BCKP
- A CKP BCKN
- A B0N BR2P
- A B0P BR2N
- A B1N BR1P
- A B1P BR1N
- A B2N BR0P
- A B2P BR0N
- B RON FB2P
- B ROP FB2N
- B R1N FB1P
- B R1P FB1N
- B R2N FB0P
- B R2P FB0N
- B G2N FG2P
- B G2P FG2N
- B G1N FG1P
- B G1P FG1N
- B G2N FG0P
- B G2P FG0N
- B CKN FCKP
- B CKP FCKN
- B B0N FR2P
- B B0P FR2N
- B B1N FR1P
- B B1P FR1N
- B B2N FR0P
- B B2P FR0N

