

LAMBDA CONTROL SYSTEM A1 V05

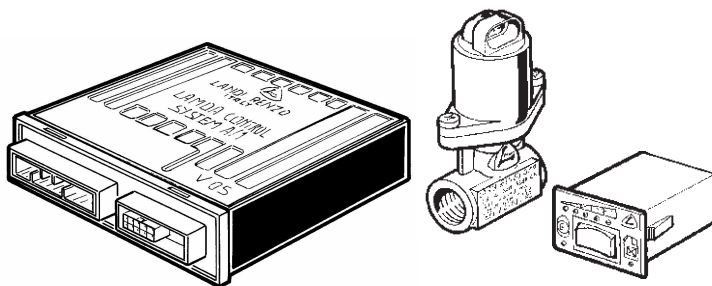

LANDI RENZO

LPG & CNG CONVERSION SYSTEMS FOR VEHICLES

LANDI RENZO S. p. A. - Via F.lli Cervi, 75/2 - 42100 Reggio Emilia - Italy
Tel. +39 / 05 22 38 26 78 - Fax +39 / 05 22 38 29 06
E-mail: Info@landi.it - <http://www.landi.it>



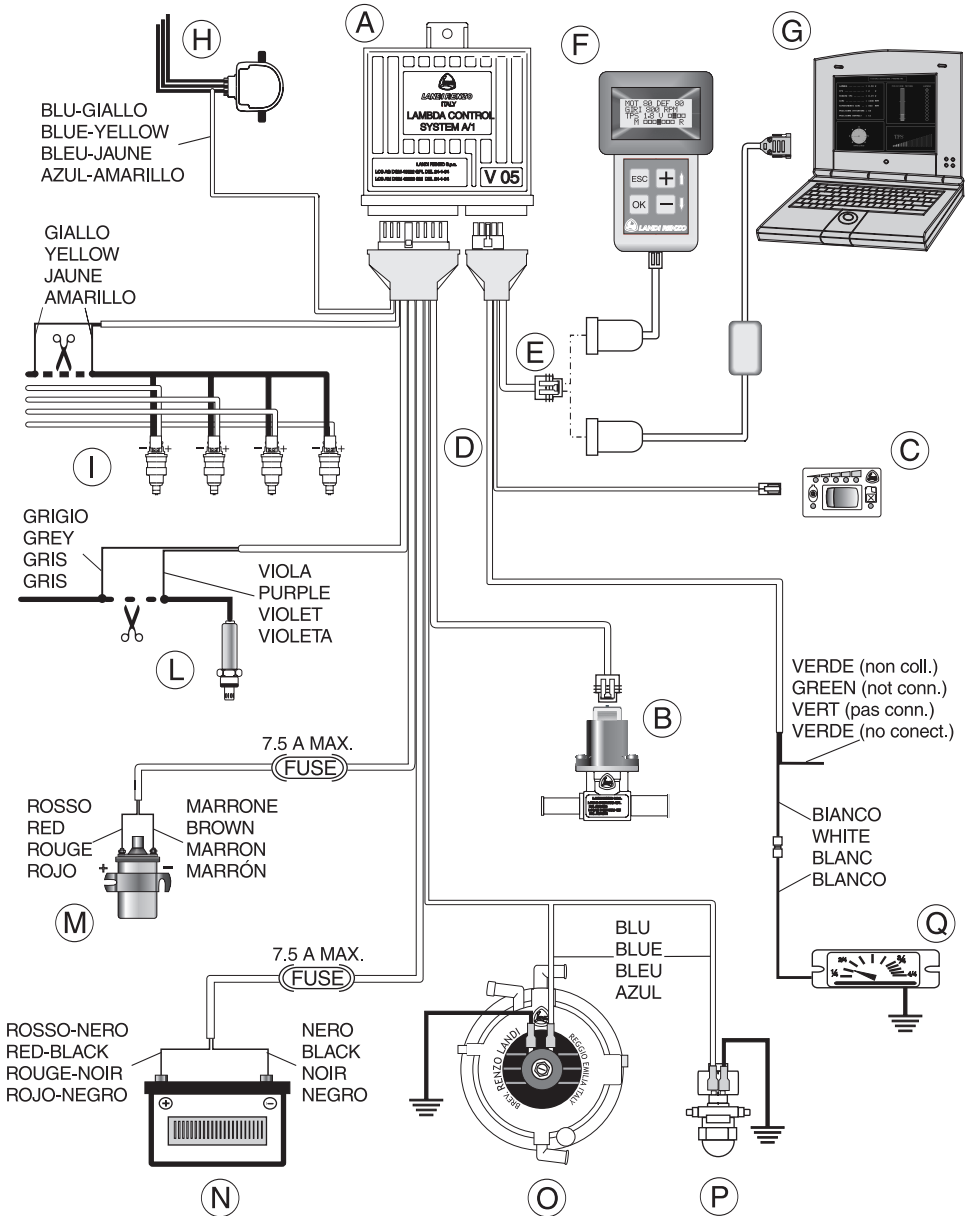

Fig. 1

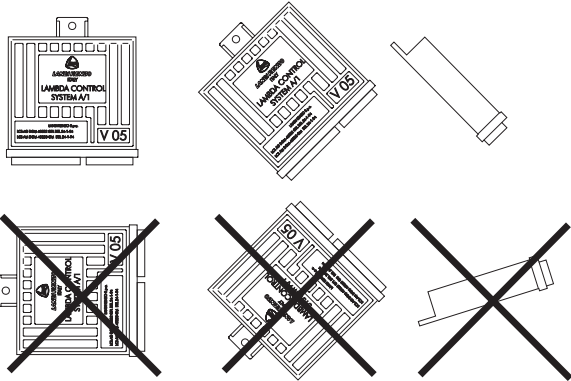

Fig. 3

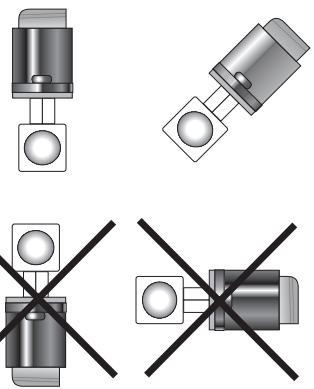

Fig. 4

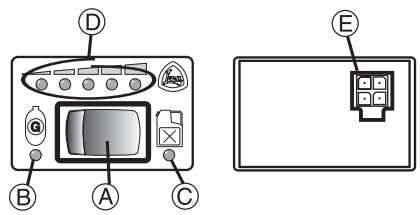

Fig. 5

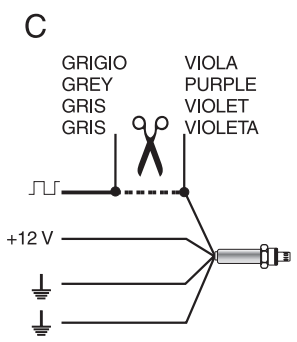
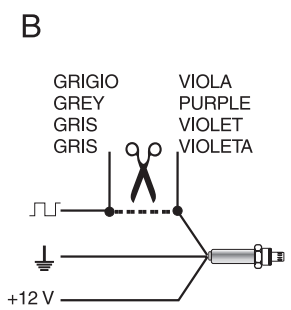
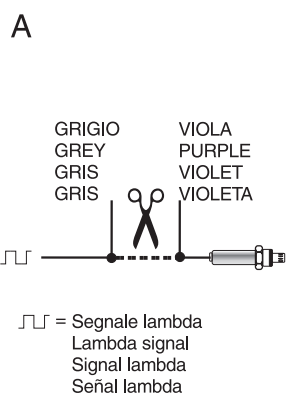

Fig. 6

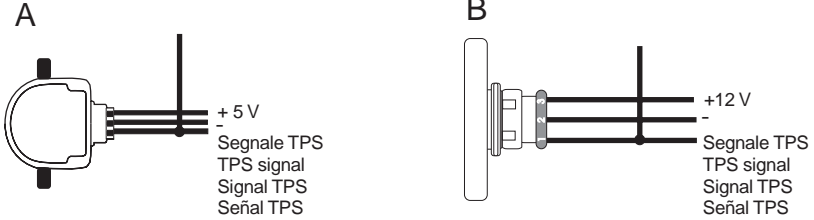
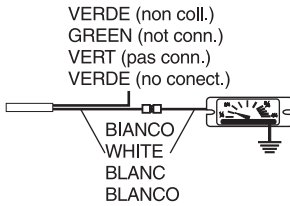
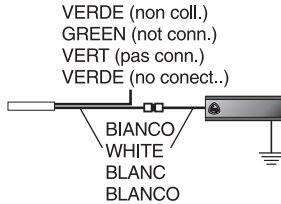

Fig. 7



LANDI RENZO GPL



LANDI RENZO METANO

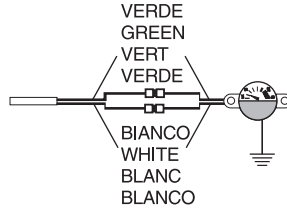

A.E.B.

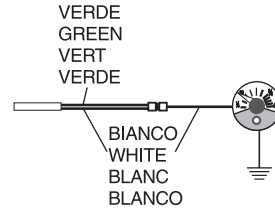

0-90 Ω

Fig. 8

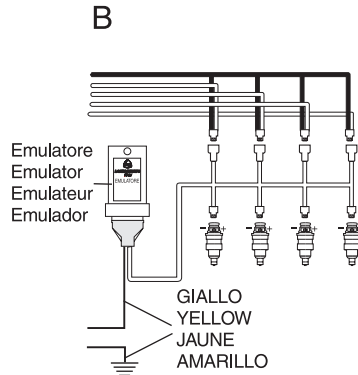
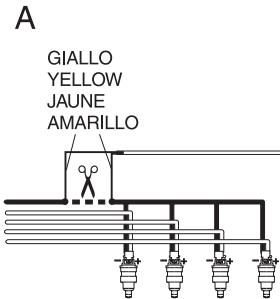

Fig. 9

2. LCS A1 V05 FUNCTIONS

LCS A1 V05 is used with following Lpg or Cng LANDI RENZO pressure regulator: SE 81, SE 81 SIC, TN1, TN1/B, TN1 SIC, TN1/B SIC.

The LCS A1 V05 Computer processes the signals from the lambda sensor, ignition, throttle position sensor TPS and holds in memory a lambda sensor tension value corresponding to the stoichiometric mixture that needs to be maintained for ever operating condition of the engine.

The lambda sensor in the exhaust manifold indicates the mixture ratio and at every moment sends a value of voltage to the LCS A1 V05 Computer which checks whether the mixture is correct by comparing it with the value set in memory; if there is a difference, the computer will drive the Linear Electromechanical Actuator, suitably changing the rate of flow of gas until the mixture comes back into the lambda stoichiometric value.

The main functions of the LAMBDA CONTROL SYSTEM A1 V05 include:

- control of carburation during gas operation;
- petrol starting with automatic switch over to gas;
- possibility of emergency gas starting by simple operation on the switch;
- electronic safety device that cuts off gas solenoid valve supply in the event of the engine accidentally stalling;
- built-in relay to cut off petrol injection with automatic change over to petrol in case of LCS A1 V05 damage;
- 'Petrol-Start' function: the Linear Electromechanical Actuator closes the gas line while running on petrol and when the engine is stopped.
- interface system (using a diagnostic connector) with a diagnostic and programming instrument Programmer - Tester V05 or Interface Kit V05 with dedicated software and serial interface for personal Computer.

3. INSTALLATION OF COMPUTER LCS A1 V05 (Fig. 3)

The Computer must be attached to the car chassis inside the engine compartment according following instructions:

- remove the fuses located on the wiring before installing the parts and replace them once installation has been completed;
- position the Computer away from sources of heat (exhaust header, radiators, etc.), protected b water and away from ignition high voltage wires;
- position the Computer with the connector side facing down to prevent any water droplets from penetrating inside the control unit through the connectors.

4. INSTALLATION OF THE LINEAR ELECTRO-MECHANICAL ACTUATOR (Fig. 4)

The Linear Electromechanical Actuator must be installed preferably at the mixer inlet (in order to optimise the cut-off function) or, in alternative, along the gas hose or on the regulator outlet.

Insert the male pin coming from the LCS A1 V05 computer to the connector on the Actuator.

IMPORTANT: never position the Linear Electromechanical Actuator with the motor facing down or in such a way that oil deposits can penetrate inside the motor.

5. INSTALLATION AND OPERATION OF SWITCH / GAUGE LCS A1 V05 (Fig. 5)

Install the Switch / Gauge LCS A1 V05 on the dashboard according following possibilities:

- insert the Switch / Gauge LCS A1 V05 in an existing hole with suitable dimensions;
- insert the Switch / Gauge LCS A1 V05 in the dashboard after making a rectangular hole (about 25x38 mm) with the LANDI RENZO cutting device for switches;
- position the Switch / Gauge LCS A1 V05 in the dashboard by using the external support provided.

5.1 SWITCH / GAUGE LCS A1 V05 OPERATION EXPLANATION

(A) gas / petrol selector

- with 2 position and indication of used fuel b mean of 2 leds (B) and (C);

(B) green led

- *turned on*: indicates the car is regular running on gas;
- *rapid flashing*: indicates the stand by for the automatic change over during the starting (that is always on petrol);
- *slow flashing*: indicates the malfunctioning of LCS A1 V05 during gas operation (see par. 5.3).

(C) yellow led

- *turned on*: indicates the car is running on petrol.

(D) led series

- indicates the level of gas (divided into fourths) present in the tank: the red led indicates the car is running on reserve.

(E) connector

- connect the switch to the wires coming from the LCS A1 V05 Computer.

5.2 EMERGENCY STARTING ON GAS WITH SWITCH / GAUGE LCS A1 V05

In case of malfunctioning during the petrol starting (ex. petrol pump damage, etc.), it is possible to start directly on gas following listed instruction:

- Turn the ignition key until the board is turned on;
- Set the switch (A) to the petrol position and return it to the gas position without starting;
- Now the green led (B) turns on;
- Start the vehicle (without turn off the board). In this condition the vehicle begin running directl with gas.

6. LCS A1 V05 ELECTRICAL CONNECTIONS

It is recommended to solder listed wire connections and insulate them properly.

6.1 RED-BLACK AND BLACK WIRES (It. N Fig. 1 and 2) COMPUTER LCS A1 V05 POWER SUPPL To deliver a continuous power to the system, made following connections of LCS A1 V05 wiring:

- *red-black wire*: connect to the battery positive

- *black wire*: connect to the battery negative

In the case the vehicle has the battery in the luggage compartment, connect the red-black wire to the positive pole in the engine compartment and the black wire to an original common earth of the electric equipment of the vehicle (ex. earth of the petrol computer or other devices such as ABS, power steering, etc.)

6.2 GREY AND VIOLET WIRES (Fig. 6) LAMBDA SENSOR CONNECTION

The connection of the lambda sensor to the LCS A1 V05 wiring is generally made by connecting both the *violet* than the *grey wires* of the LCS A1 V05 Computer on the outlet signal of lambda sensor.

In some model of vehicles it could be necessary to connect only the *violet wire* of the LCS A1 V05 Computer, while the *grey* one will be proper insulated.

The explanation are shown case per case in the TECHNICAL SHEET of the Technical Assistance Service *LANDI RENZO*.

In order to facilitate the identification of the lambda signal wire, herebelow are listed the most common type of lambda sensor:

- *one-wire lambda sensor*: individuate the wire that from the lambda sensor reaches the petrol computer (Fig. 6A);
- *two-wire lambda sensor*: use a tester to individuate the lambda signal wire: on this wire the voltage with respect to ground could varies between 0÷1V, 0,8÷1,6V or 0÷5V);

• three-wires lambda sensor: individuate the lambda signal wire as previous point. The other 2 wires are used to heat the sensor: one has a 12V tension and the other is a negative (Fig. 6B).

• four-wires lambda sensor: individuate the lambda signal wire as previous point. Other 2 wires are used to heat the sensor (see above), while one wire is the negative of the lambda sensor (Fig. 6C).

6.3 BLUE-YELLOW WIRE (Fig. 7) TPS SIGNAL CONNECTION

The TPS signal communicates the position of the acceleration throttle to the petrol computer. The connection of the TPS to the LCS A1 V05 wiring is made according following instructions:

• Proportional TPS (Fig.7A): the output signal from this sensor has a voltage that is proportional to the throttle position. This type of sensor has 3 wires:

- one has a power supply voltage of +5V, with the instrument panel on;

- one is connected to the battery negative;

- one is the sensor output and must be connected to the blue-yellow wire of the LCS A1 V05. The voltage at the ends of this wires, with respect to ground, varies from 0 to 5V.

• Switch type TPS (Fig. 7B): the wires on this sensor are similar to those on a proportional TPS above described. The output signal from this sensor has only 2 conditions: 0 Volts with throttle closed and 12 Volts with the throttle is in out of idling condition or vice versa. Identify the wire that is the output signal of TPS by means of a tester (making sure that the measurements are performed with reference to ground) and connect the same to the blue-yellow wire of the LCS A1 V05.

6.4 BROWN WIRE (It. M Fig. 1 and 2) ENGINE RPM SIGNAL CONNECTION

Connect the brown wire of LCS A1 V05 to the negative of the ignition coil or, as an alternative, to the speed indicator wire according following instructions:

• connection to the coil negative of a vehicle with a 4 cylinder engine with 2 coils or 1 double coil: set the LCS A1 V05 Computer at the parameter 'NUMBER OF CYLINDERS / TYPE OF IGNITION' ⇒ DOUBLE COIL.

• connection to the coil negative of a vehicle with one coil that supply all the cylinders by means of a distributor: set the LCS A1 V05 Computer at the parameter 'NUMBER OF CYLINDERS / TYPE OF IGNITION' ⇒ MONO COIL.

In both cases you have not to set the parameter concerning the number of cylinders. On the contrary, in the case in which the ignition system of the vehicle has a distributor or in the case you made a connection to the speed indicator of the vehicle, it is necessary to set the number of cylinder (and not to set the type of coil).

6.5 RED WIRE (It. M Fig. 1 and 2) 12V IGNITION KEY CONNECTION

Connect the red wire of LCS A1 V05 to a key device such as the positive of the ignition coil or to another wire that supplies 12V when the board is turned on.

6.6 WHITE AND GREEN WIRES (Fig. 8) CONNECTION TO THE GAS LEVEL SENSOR

The LCS A1 V05 Computer operates with different gas level sensors available on the market according following instructions:

- LANDI RENZO type Lpg/Cng sensor: connect the white wire of LCS A1 V05 to the white wire of the gas level sensor; the green wire remains disconnected, insulating its end.

- A.E.B. type sensor: connect both green and white wires of LCS A1 V05 to the respective green and white wires of the gas level sensor.

- 0-90 Ω type sensor: connect both green and white wires of LCS A1 V05 to the gas level sensor wire.

Electrical connections

LCS A1 V05 operation

6.7 YELLOW WIRES (Fig. 9)

DISCONNECTING THE INJECTORS

The yellow wires of LCS A1 V05 are connected to the contacts of a normally closed relay. During gas operation, (Fig. 9A) the contacts of the relay open, thus preventing the injectors from operating; when the engine is fed with petrol, these contacts remain closed.

Set the LCS A1 V05 Computer at the parameter 'OVERLAP TIME' preferable retard timing (in seconds) of the contacts open in order to have a suitable fuel overlapping during change from petrol to gas. The maximum applicable current as a continuous load is 6.5 A.

If an *electronic emulator* is used to disconnect the injectors (Fig. 9B) and it is necessary to set a fuel overlapping time, connect one end of the yellow wires of LCS A1 V05 to ground and the other to the special connector on the electronic emulator.

NOTE: during gas operation, in case of eventual malfunctioning of the injector disconnection system, LCS A1 V05 will change automatically on petrol.

7. LCS A1 V05 OPERATION

The programmable functions of LCS A1 V05 can be set only by the Programmer Tester V05 or by a personal computer with Interface Kit V05 and dedicated software.

Also when the LCS A1 V05 is not fed (ex. batter disconnected), the memorised functions are stored.

For more details, see the 'Instruction Manual Programmer Tester V05'.

Data display

LCS A1 V05 progr. functions

7.1 DATA DISPLAY

By the Programmer Tester V05 (or personal computer with Interface Kit V05 installed) following data are displayed:

- **ACT:** indicates (in number of steps) the actual position of the Linear Electromechanical Actuator
- **DEF:** indicates (in number of steps) the acquired default position (standard value) of the Linear Electromechanical Actuator
- **RPM:** indicates (in rpm) the actual number of revolutions of the engine
- **TPS:** indicates (in volt) the position of the throttle position sensor
- **TPS LEARNING RANGE:** indicate if you are in an idling condition, cruise condition or maximum open throttle condition
- **LAMBDA SENSOR LEARNING RANGE:** indicate if you are in a poor or rich mixture condition

With LCS A1 V05 Computer new or resetted the 'DEF' position of the Linear Electromechanical Actuator is *100 steps*.

The *minimum TPS position* and the *default position* of the Linear Electromechanical Actuator are acquired at every ignition of the system; the last acquired default is used as starting position.



7.2 LCS A1 V05 PROGRAMMABLE FUNCTIONS

Here below are indicated the programmable functions of LCS A1 V05 with relevant programming menu and options in which are pointed out in **bold type** the standard parameters settled with Computer new or resetted.

- NUMBER OF CYLINDER / TYPE OF IGNITION:
DOUBLE-COIL, SINGLE-COIL, 4/5/6/8 CYLINDERS

- RPM SIGNAL:
STANDARD, WEAK

- PETROL/GAS AUTOMATIC CHANGE:
IN DECELERATION, IN ACCELERATION, GAS STARTING (only if enabled)

- PRIMING TIME: (only if enabled gas starting)
0,0 - 5,0 sec (0,8 sec)

- TEMPERATURE FOR CHANGE: (only if enabled)
20° - 40° (30°)

- RPM FOR AUTOMATIC CHANGE:
400 - 9.000 RP (2.000 RPM)

- FUEL OVERLAPPING TIME DURING AUTOMATIC CHANGE:
0,000 - 1,000 SEC. (0,400 SEC.)

- TPS (THROTTLE POSITION SENSOR):
LINEAR 0-5V, LINEAR 5 - 0V, SWITCH 0 - 12V, SWITCH 12 - 0V, MONO BOSCH, TPS ADAPTER

- GAS LEVEL SENSOR:
LANDI RENZO, A.E.B., 0-90 OH

- LAMBDA SENSOR:
0 - 1V, 0,8 - 1,6V, 0 - 5V 'A', 0 - 5V 'B', 5 - 0V 'A', 5 - 0V 'B'

- LAMBDA SENSOR READING DELAY:
0 - 1.250 SEC. (5 SEC.)

- LAMBDA SENSOR EMULATION:
SQUARE WAVE, DISCONNECTED, GROUND

- SQUARE WAVE EMULATION (only if selected previous option): **HIGH TIM (0,36 SEC.), LOW TIME (0,36 SEC.), DISCONNECTED SENSOR TIME (0,00 SEC.), NUMBER OF WAVES AFTER DISCONNECTION (0)**

- ACTUATOR-MAX DEVIATION IN ACCELERATION:
NOT ENABLED, 40 - 240 STEPS (100 STEPS if enabled)

- TPS DURING DEVIATION: (only if selected previous option) **1,5 - 5,0V (2,8V)**

- ACTUATOR-MAX HIGH POSITION:
20 - 240 STEPS (240 STEPS)

- TPS TO RELEASE LIMITATION: (only if selected relevant options) **0,0 - 5,0V (2,8V)**

- ACTUATOR-MAX LOW POSITION:
20 - 240 STEPS (20 STEPS)

- CUT-OFF OPTION:
NOT ENABLED, ENABLED

- MINIMUM RPM FOR CUT-OFF: (only if selected previous option) **400 - 9.000 RP (1.500 RPM)**

- ACTUATOR-MAX POSITION FOR CUT- OFF: (only if selected previous option) **40 - 240 STEPS (80 STEPS)**

- ACTUATOR-MAX INCREASE IN ACCELERATION:
NOT ENABLED, ENABLED

- TPS DEVIATION FOR INCREASE: (only if selected previous option) **0,1 - 3,0V (0,3V)**

- NUMBER STEPS FOR INCREASE: (only if selected previous option) **0 - 30 STEPS (5 STEPS)**

- ACTUATOR-MAX POSITION FOR FIXED DEFAULT:
NOT ENABLED, 20 - 240 STEPS (100 STEPS if enabled)

- LCS A1 V05 MEMORY RESETTING: OK TO CONFIRM allows to re-set the standard values (in **bold type**) of LCS A1 V05 Computer

7.3 NOTES CONCERNING THE LCS A1 V05 PROGRAMMATION

The standard emulation of the lambda sensor is settled as TYPE OF LAMBDA SENSOR EMULATION ⇒ SQUARE WAVE. This kind of emulation is used for the main part of the vehicles and must be changed only if allowed from the TECHNICAL MANUAL LANDI RENZO MT012.

The lambda sensor emulation of vehicles with *Monoinjector Bosch* (for which the parameter TYPE OF TPS ⇒ MONO BOSCH) is made programming the parameter TYPE OF EMULATION ⇒ GROUND. On this vehicles the yellow-blue wire of LCS A1 V05 must be connected to the wire n. 2 (and not to the wire n. 4) of the TPS connector at side of the throttle body.

In the case some *error messages* are displayed on the Programmer Tester V05 (or personal computer with Interface Kit V05) as for example 'OK TO RESET TESTER', or in the case it is not possible to dialogue with LCS A1 V05 Computer, it is necessary to disconnect both the computer connectors and let them disconnected for at least 3 minutes in order to reset completely the internal circuits. After you will precede with a ne programmation.

7.4 MALFUNCTIONING DIAGNOSIS

The Switch / Gauge LCS A1 V05 is in the position to point out to the installer or the driver some error conditions. While the car is running on gas, if the green led D (letter B Fig. 5) begins flashing slowly, this indicates that one of the following error conditions has occurred:

- lambda sensor is not working;
- lambda sensor detects a rich mixture for too long;
- lambda sensor detects a lean mixture for too long;

The type of error, even if no longer indicated the next time the car is started, is permanent recorded in the memory of the LCS-A1 V05. Use the Programmer Tester V05 or the Interface Kit V05 to display the type of error and, once the problem has been solved, it can be cancelled from memory.

8. CARBURATION LEARNING PROCEDURE WITH LCS A1 V05

To learn the carburation with LCS A1 V05 follow listed instructions:

- a) Replace the fuses on the wiring (fuses removed during the installation of LCS A1 V05).
- b) Connect the Programmer Tester V05 (or the personal computer with Interface Kit V05 installed) to the diagnostic and programming outlet located on the LCS A1 V05 Computer wiring,
- c) Use the Programming Tester V05 (or the personal computer) to adequate option per option the parameters of LCS A1 V05 Computer to the specification of the vehicles (see par. 7.2).

d) Check that the set values on LCS A1 V05 Computer are exactly correspondent to the characteristics of the vehicles. If not, reset the memory of LCS A1 V05 and check that it memorise the standard values pointed out in bold type on the paragraph 7.2; after, set another time the parameters of LCS A1 V05 Computer and repeat the verify.

e) Start the car with the Switch / Gauge LCS A1 V05 in petrol position and wait a few minutes for the lambda sensor to heat up.

f) Enter in the 'DISPLAY' page of the Programming Tester V05 (or personal computer).
0,0 - 5,0V (2,8V)

g) With the car stationary, switch to gas and accelerate and decelerate at intervals of a few seconds; this will allow the LCS A1 V05 Computer to learn the position of the TPS minimum.

h) At this point the regulator peak speed is adjusted: rev the engine to about 3.500 rpm. until when the default value is learned (the number on the Tester Programmer displayed at the parameter 'DEF' will change).

i) Then the regulator idling speed is adjusted: with the engine running, turn the idle speed setting screw until, on the Tester Programmer V05 (or personal computer) the number of steps of the Actuator indicated in menu 'Display' at the word 'ACT' is equal (or as close as possible) to the value indicated at the word 'DEF'.

l) After a few seconds, the lambda signal will begin shifting, indicating that the carburation has been learned.

m) Check with the exhaust gas analyser that the lambda value is equal to about 1,000 and that CO, HC and CO₂ are as shown on the prospect of the LANDI RENZO regulators installation and adjustment manual.

n) When idling and peak speed are adjusted, carry out a road test.

Date, descriptions and illustrations are indicatory. LANDI RENZO S.p.A. reserves the right to improve or modify them without prior notification.