

Cree® XLamp® XR LED

Data Sheet

Cree XLamp LEDs combine the brightness of power LED chips with a rugged package capable of operating in excess of one watt. Cree XLamp LEDs lead the solid-state lighting industry in brightness while providing a reflow-solderable design that is optimized for ease of use and thermal management. Lighting applications featuring XLamp LEDs maximize light output and increase design flexibility, while minimizing environmental impact.

Cree XLamp LEDs bring the power of brightness to a wide range of lighting and backlighting applications including portable lighting and flashlights, computer and television screens, signaling, architectural, landscaping and entertainment/advertising installations.



FEATURES

- Full range of drive currents up to 700 mA
- Surface-mount technology — reflow solderable
- Wide range of colors
 - White, Royal Blue, Blue, Cyan, Green, Amber, Red-Orange and Red
- Low operating voltage
- Electrically neutral thermal path
- RoHS-compliant — lead-free
- Integrated lens
- Small footprint — 7.0 mm x 9.0 mm
- ESD > 2000 V
- Lumen Maintenance of greater than 70% on average after 50,000 hours

Table of Contents

Flux Characteristics ($T_j = 25^\circ\text{C}$).....	2
Characteristics	2
Relative Spectral Power Distribution	3
Typical Electrical Characteristics ($T_j = 25^\circ\text{C}$)	4
Thermal Design.....	4
Relative Flux vs. Current ($T_j = 25^\circ\text{C}$)	5
Typical Spatial Distribution.....	5
Photometric Output vs. Junction Temperature ($I_f = 350\text{ mA}$)	6
Reflow Soldering Characteristics	7
Notes.....	8
Mechanical Dimensions ($T_j = 25^\circ\text{C}$).....	9
Tape and Reel	10
Dry Packaging and Packaging	11

Flux Characteristics (T_j = 25°C)

Color	Dominant wavelength (nm)		Typical Luminous or Radiant flux @ 350 mA
	Min.	Max.	
Royal Blue	455	465	255 mW
Blue	465	475	15 lm
Cyan	500	510	45 lm
Green	520	535	52 lm
Amber	585	595	42 lm
Red-Orange	610	620	49 lm
Red	620	635	40 lm

Color	CCT (K)		Typical Luminous or Radiant flux @ 350 mA
	Min.	Max.	
Global White	5000	10000	51 lm
White	5000	10000	46 lm
	3500	5000	43 lm
	2600	3500	37 lm

Note: Cree maintains a tolerance of +/- 7% on flux and power measurements.

Characteristics

Characteristics	Unit	Min	Typical	Max
Thermal Resistance, junction to solder point (white, royal blue, blue, cyan, green)	°C/W		8	
Thermal Resistance, junction to solder point (amber, red-orange, red)	°C/W		15	
Viewing angle (FWHM)	degrees		100	
Temperature coefficient of voltage (royal blue, blue, cyan, green, white)	mV/°C		-3.0 to -2.8	
Temperature coefficient of voltage (amber, red-orange, red)	mV/°C		-3.2 to -3.0	
ESD Classification (HBM per Mil-Std-883D)			Class 2	
DC Forward Current (royal blue, blue, cyan, green, red-orange, red, white > 4444K)	mA			700
DC Forward Current (amber, white < 4444K)	mA			350
DC Pulse Current (white, royal blue, blue, cyan, green @ 1 kHz, 10% duty cycle)	A			1.8
DC Pulse Current (amber, red-orange, red @ 1 kHz, 10% duty cycle)	A			1.0
Reverse Voltage	V			5
Forward Voltage @ 350 mA (royal blue, blue, cyan, green, white)	V		3.4	4.0
Forward Voltage @ 350 mA (amber, red-orange, red)	V		2.25	3.0
LED Junction Temperature	°C			145
Operating Temperature	°C	-40		85

For details on Cree's procedures for sorting, binning and labeling and a list of standard order codes, see the application note [Cree XLamp XR LED Binning and Labeling](#).

Relative Spectral Power Distribution

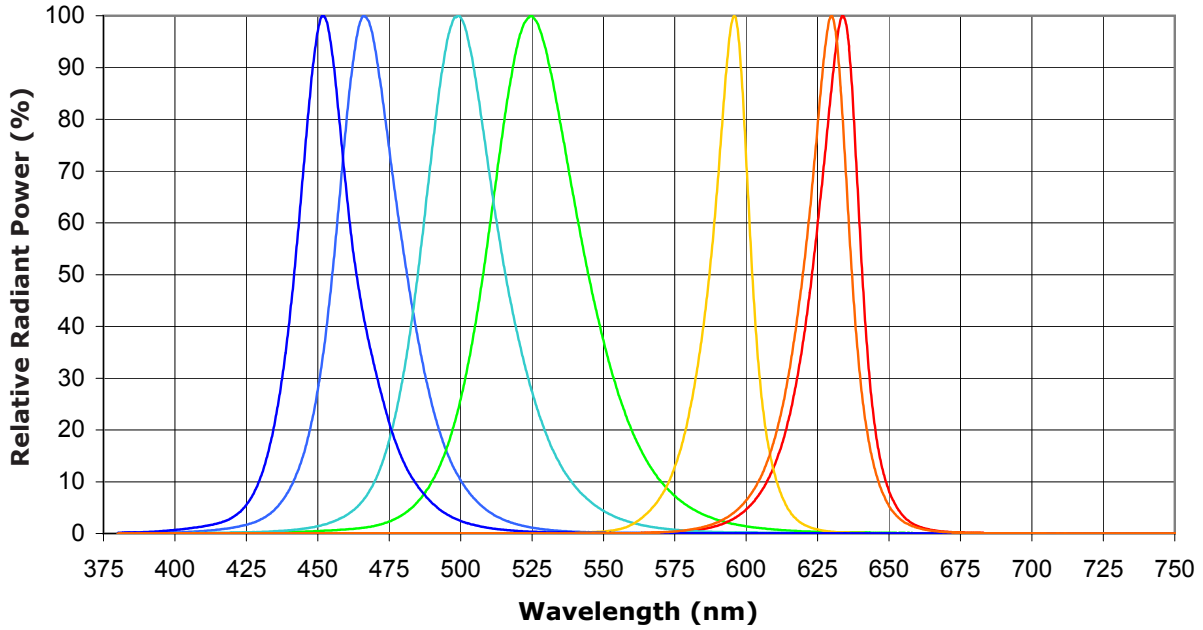

Royal Blue, Blue, Cyan, Green, Amber, Red-Orange, Red

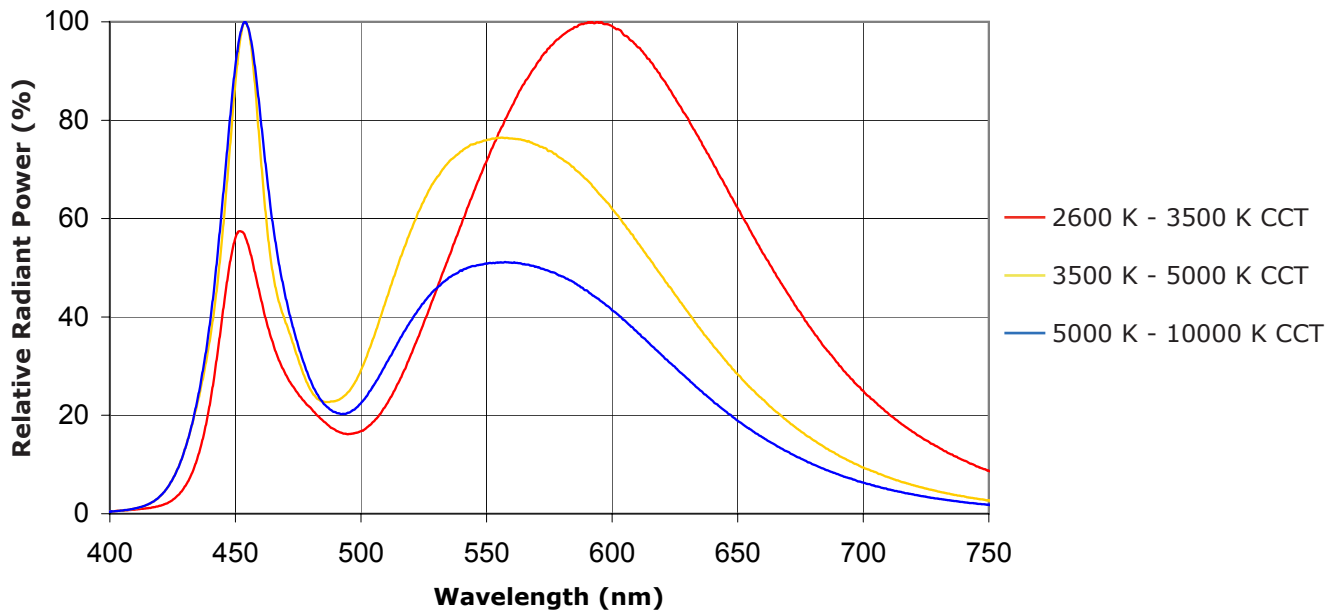

White

Typical Electrical Characteristics ($T_j = 25^\circ\text{C}$)

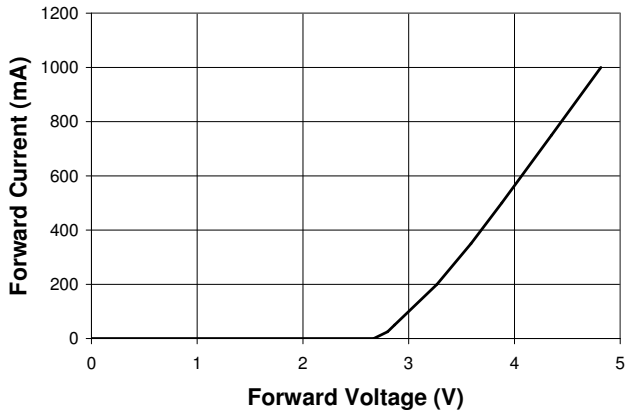

White, Royal Blue, Blue, Cyan, Green

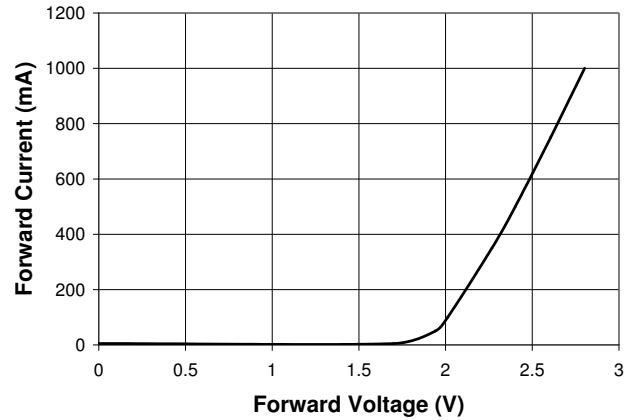

Red, Red-Orange, Amber

Thermal Design

The maximum forward current is determined by the thermal resistance between the LED junction and ambient. Given an existing thermal resistance of $8^\circ\text{C}/\text{W}$ between the junction and the solder point, it is crucial for the end product to be designed in a manner that minimizes the thermal resistance from the solder point to ambient in order to optimize lamp life and optical characteristics.

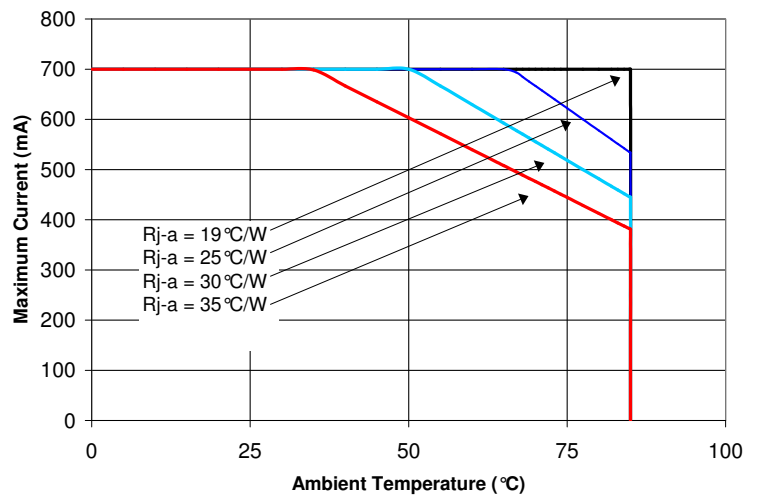

Relative Flux vs. Current ($T_1 = 25^\circ\text{C}$)

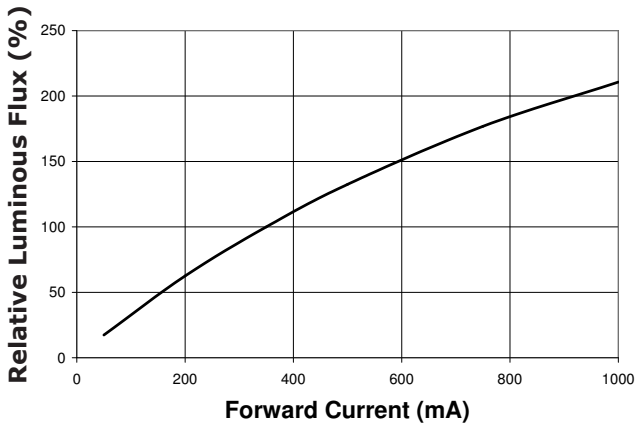

White, Royal Blue, Blue, Cyan, Green

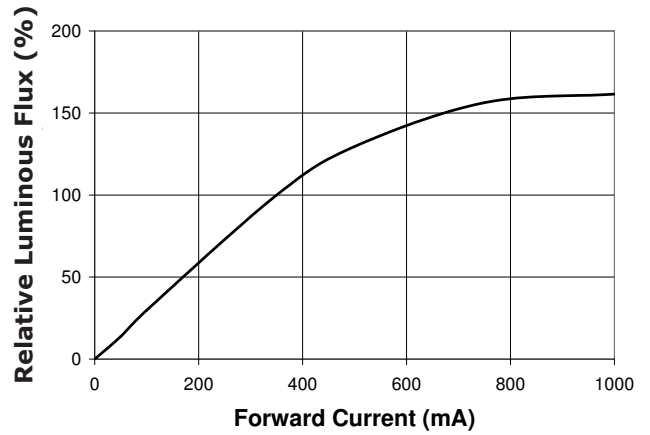

Red, Red-Orange, Amber

Typical Spatial Distribution

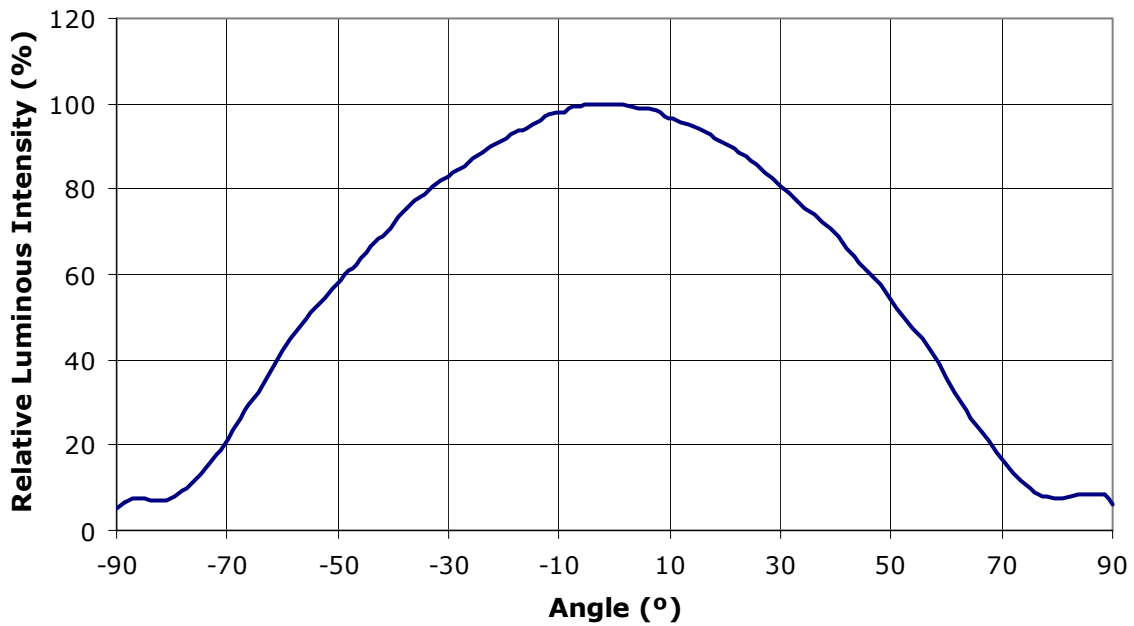

Photometric Output vs. Junction Temperature ($I_f = 350$ mA)

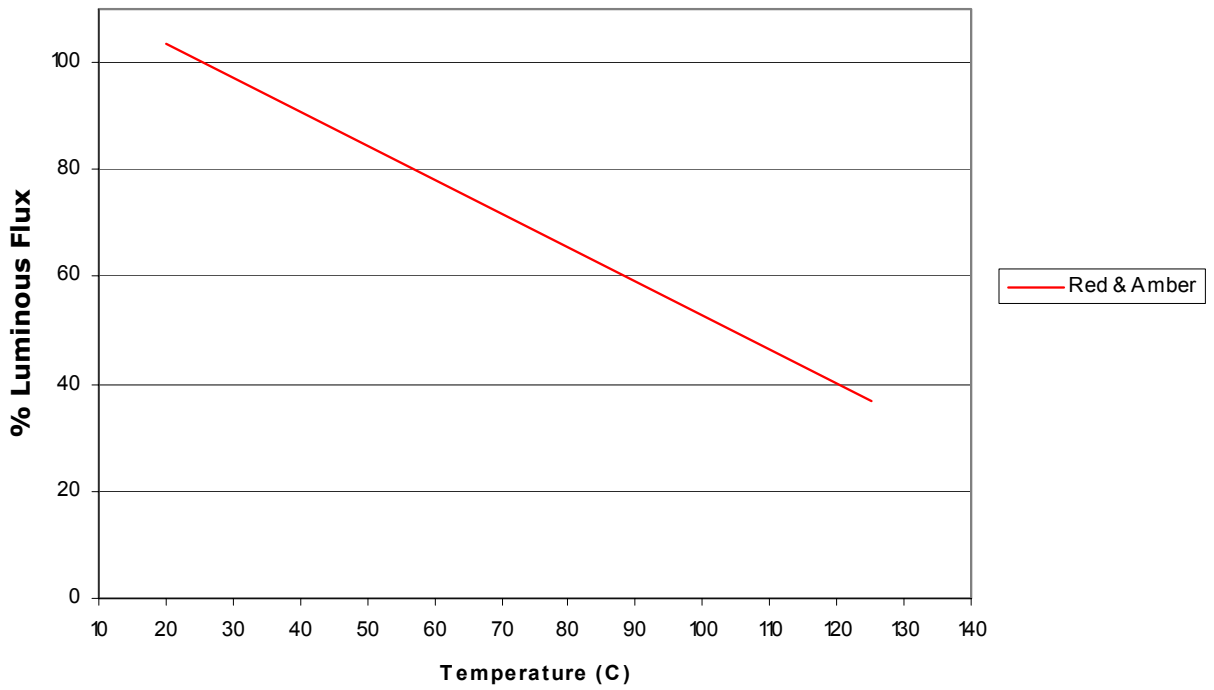
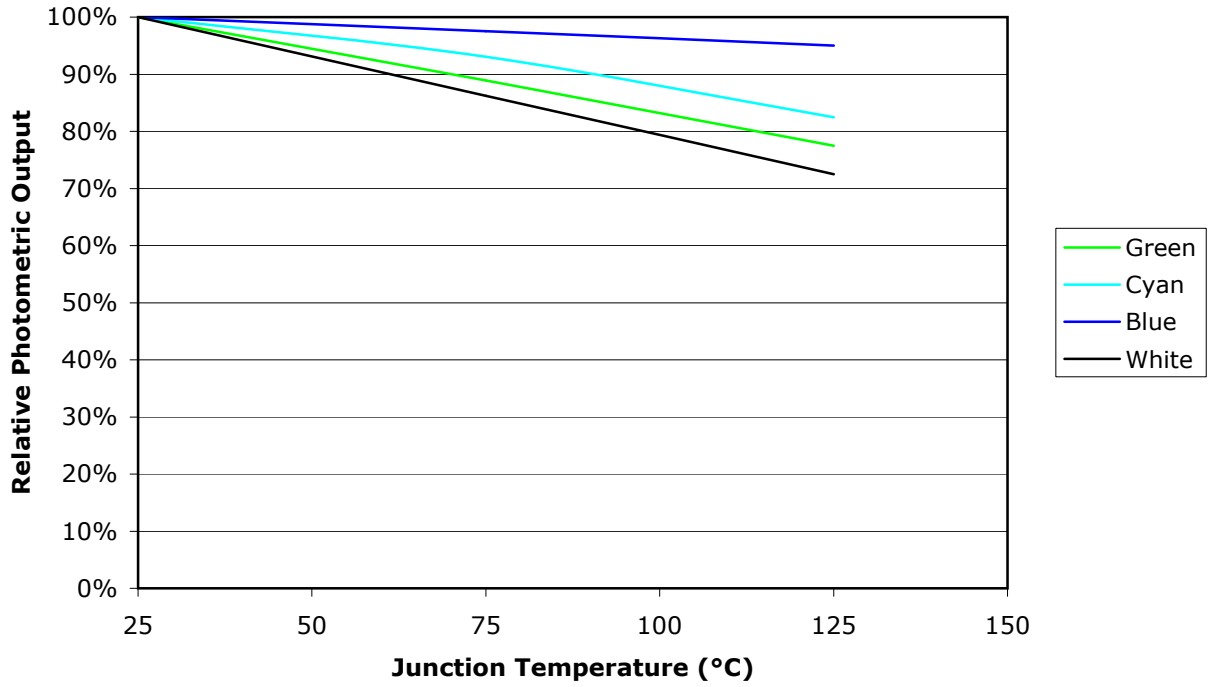

Reflow Soldering Characteristics

The following reflow soldering profiles are provided for reference. Cree recommends that users follow the recommended soldering profile provided by the manufacturer of the solder paste used. Cree XLamp LEDs are compatible with JEDEC J-STD-020C.

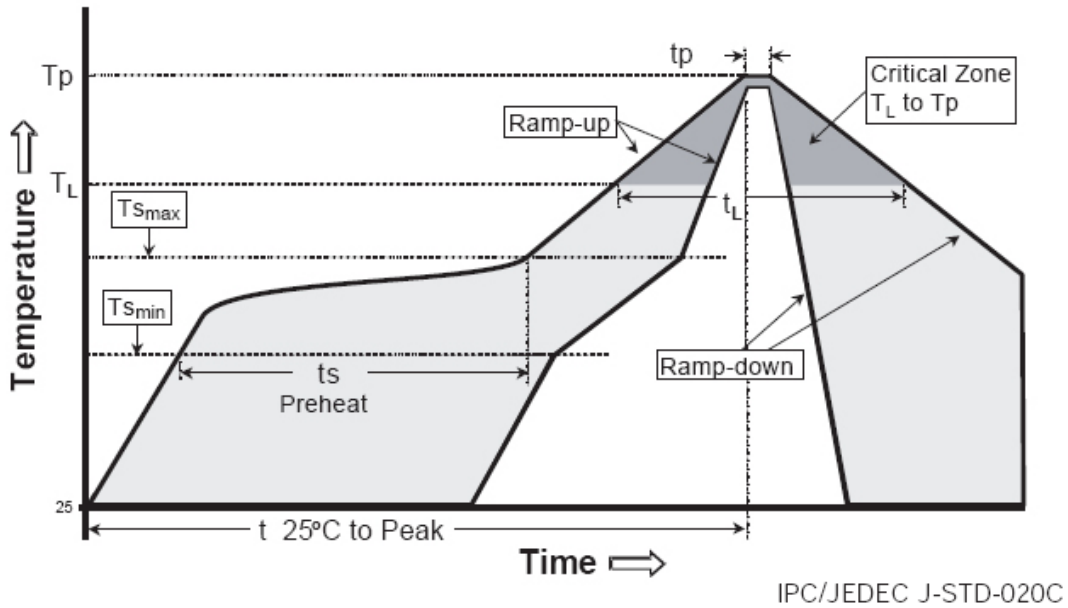

Profile Feature	Lead-Based Solder	Lead-Free Solder
Average Ramp-Up Rate ($T_{s_{max}}$ to T_p)	3°C/second max.	3°C/second max.
Preheat: Temperature Min ($T_{s_{min}}$)	100°C	150°C
Preheat: Temperature Max ($T_{s_{max}}$)	150°C	200°C
Preheat: Time ($t_{s_{min}}$ to $t_{s_{max}}$)	60-120 seconds	60-180 seconds
Time Maintained Above: Temperature (T_L)	183°C	217°C
Time Maintained Above: Time (t_L)	60-150 seconds	60-150 seconds
Peak/Classification Temperature (T_p)	215°C	260°C
Time Within 5°C of Actual Peak Temperature (t_p)	10-30 seconds	20-40 seconds
Ramp-Down Rate	6°C/second max.	6°C/second max.
Time 25°C to Peak Temperature	6 minutes max.	8 minutes max.

Note: All temperatures refer to topside of the package, measured on the package body surface.

Notes

Lumen Maintenance Projections

Based on internal long-term reliability testing and standardized forecasting methods, Cree projects XLamp LEDs to maintain an average of 70% lumen maintenance after 50,000 hours, provided the LED junction temperature is maintained at or below 80°C.

Please read the XLamp Reliability application note for more details on Cree’s lumen maintenance testing and forecasting. Please read the XLamp Thermal Management application note for details on how thermal design, ambient temperature, and drive current affect the LED junction temperature.

Moisture Sensitivity

XLamp LEDs are shipped in sealed, moisture-barrier bags (MBB) designed for long shelf life. If XLamp LEDs are exposed to moist environments after opening the MBB packaging but before soldering, damage to the LED may occur during the soldering operation. The following derating table defines the maximum exposure time (in days) for an XLamp LED in the listed humidity and temperature conditions. LEDs with exposure time longer than the time specified below must be baked according to the baking conditions listed below.

Temperature	Maximum Percent Relative Humidity						
	30%	40%	50%	60%	70%	80%	90%
30°C	9	5	4	3	1	1	1
25°C	12	7	5	4	2	1	1
20°C	17	9	7	6	2	2	1

Baking Conditions

It is not necessary to bake all XLamp LEDs. Only the LEDs that meet all of the following criteria must be baked:

1. LEDs that have been removed from the original MBB packaging
2. LEDs that have been exposed to a humid environment longer than listed in the Moisture Sensitivity section above
3. LEDs that have not been soldered

LEDs should be baked at 80°C for 24 hours. LEDs may be baked on the original reels. Remove LEDs from MBB packaging before baking. Do not bake parts at temperatures higher than 80°C. This baking operation resets the exposure time as defined in the Moisture Sensitivity section above.

Storage Conditions

XLamp LEDs that have been removed from original MBB packaging but not soldered yet should be stored in a room or cabinet that will maintain an atmosphere of 25 ± 5°C and no greater than 10% RH (relative humidity). For LEDs stored in these conditions, storage time does not add to exposure time as defined in the Moisture Sensitivity section above.

RoHS Compliance

The levels of environmentally sensitive, persistent biologically toxic (PBT), persistent organic pollutants (POP), or otherwise restricted materials in this product are below the maximum concentration values (also referred to as the threshold limits) permitted for such substances, or are used in an exempted application, in accordance with EU Directive 2002/95/EC on the restriction of the use of certain hazardous substances in electrical and electronic equipment (RoHS), as amended through April 21, 2006.

Vision Advisory Claim

Users should be cautioned not to stare at the light of this LED product. The bright light can damage the eye.

Mechanical Dimensions (T_a = 25°C)

All measurements are ±.1mm unless otherwise indicated.

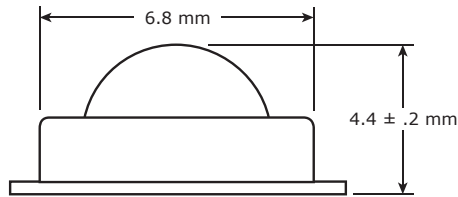
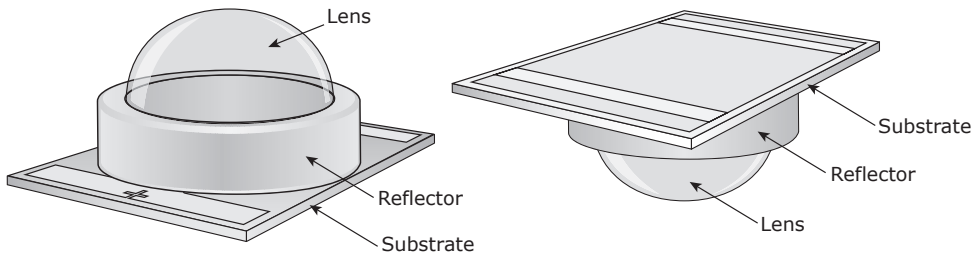

Side View

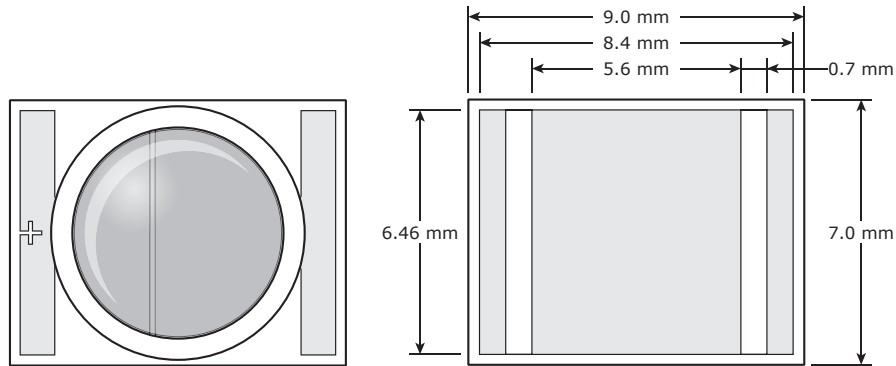

Top View

Bottom View

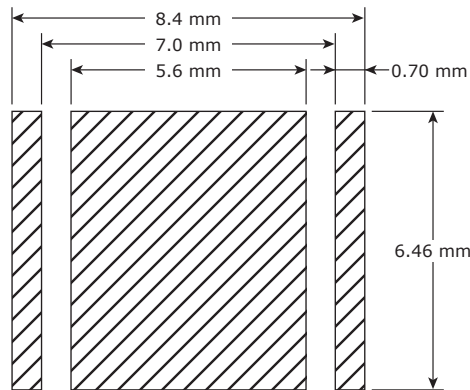

Recommended PC Board Solder Pad

Tape and Reel

All dimensions in mm.

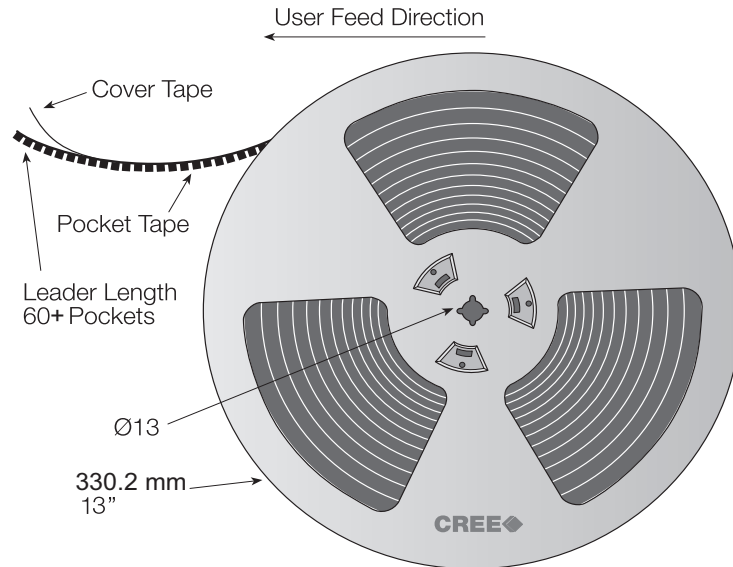
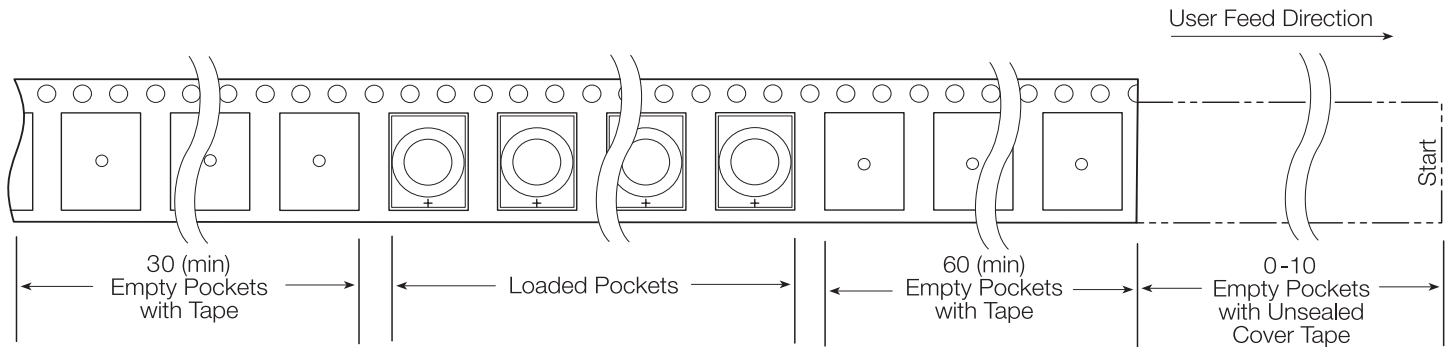
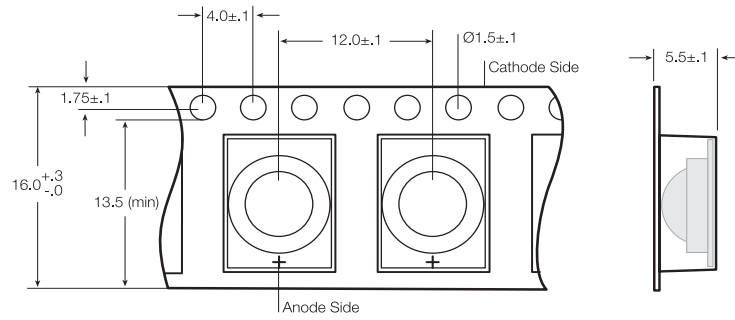

Dry Packaging and Packaging

