

Audio IC Application Circuit

TAN-327

Example of 3-V FM Radio Circuit
TA2159F Compact FM Tuner Module Reference Model

Outline

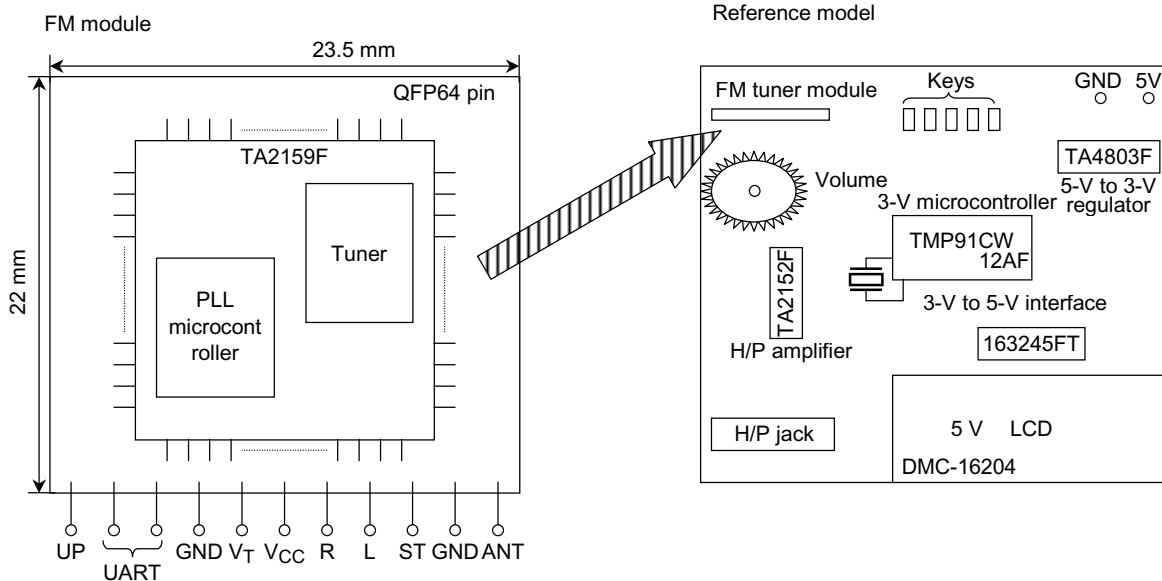

This is an application circuit example of an FM radio reference model targeting compact sets such as cellular phones, mobile devices, PDA, and MP3. The TA2159F is a QFP64-pin IC, which is integrated an FM front-end, an FM IF amp detector, a stereo decoder, a PLL circuit, and a PLL control microcontroller. The FM tuner module can be used to tune in FM by itself. Please refer to the specifications for microcontroller from the page nine of this technical datasheet and the reference model diagram.

FM Tuner Module Characteristics

Characteristic	Rating	Unit
Supply voltage	3	V
Current dissipation (quiescent)	19	mA
Signal frequency range	87.5 to 108	MHz
Intermediate frequency	10.7	MHz
Sensitivity	18	dB μ V EMF

Diagram showing all circuits in reference model

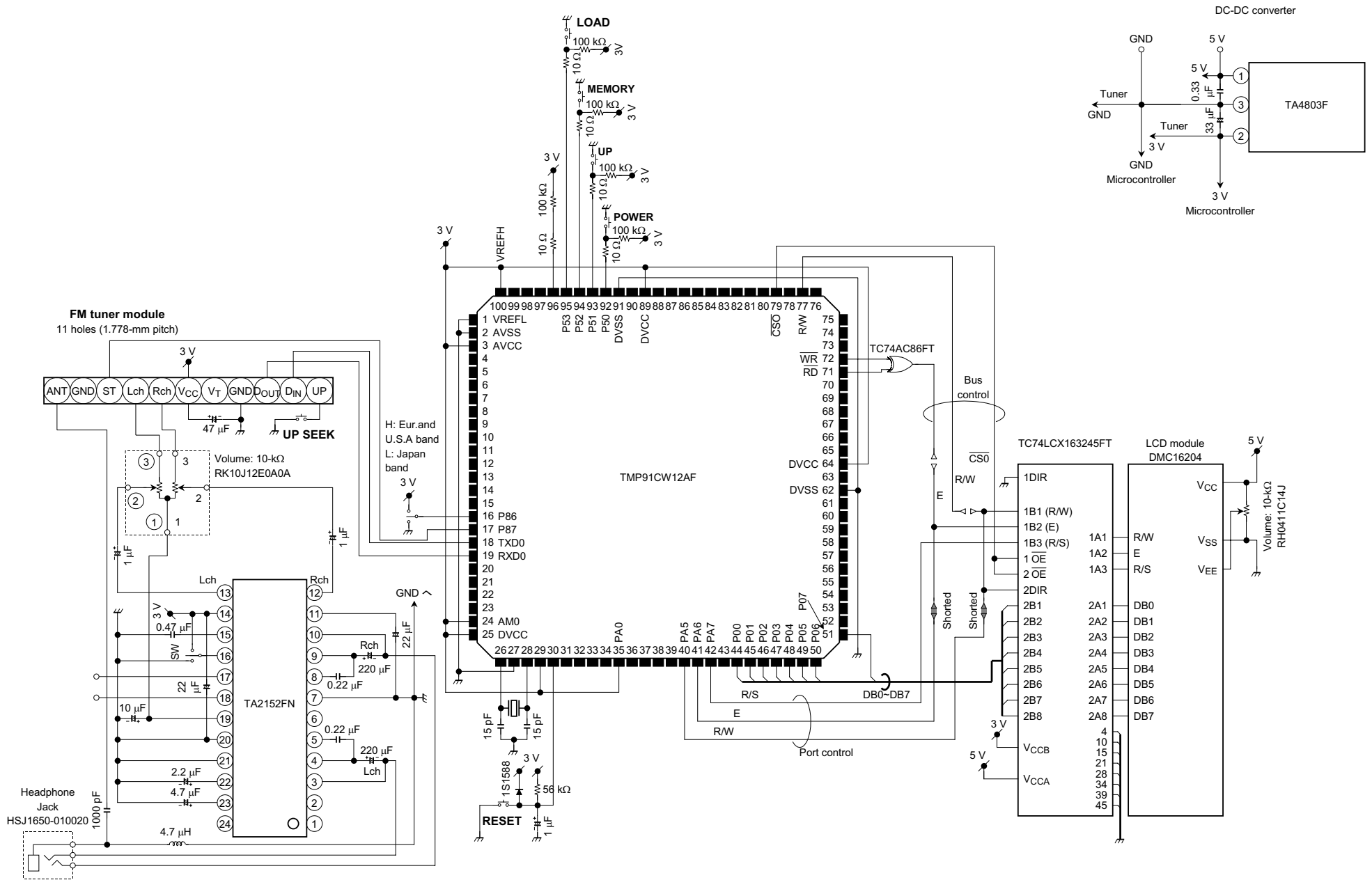

Application circuit of FM tuner module

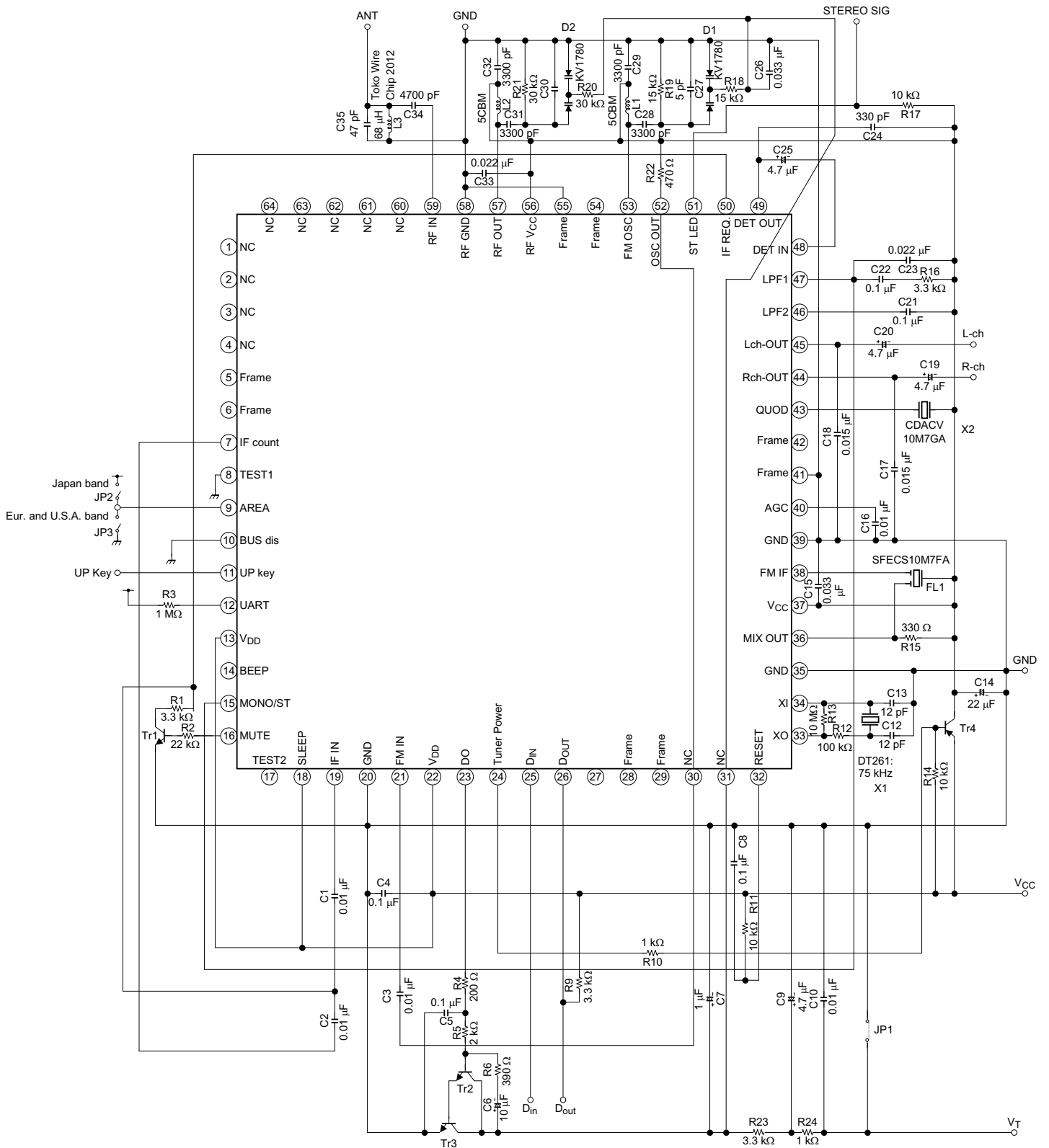

Coil specifications

No.	Application	f (Hz)	L (μH)	C _O (pF)	Q _O	Turns				Wire	Reference
						1-2	2-3	1-3	4-6		
L1	RF1 in Eur. and U.S.A.	100 M	—	33.4	61	—	—	3	—		657AN-1609 (red)
L2	OSC in U.S.A.	100 M	—	40.2	67	—	—	3	—		657AN-1608BIT (black)
L1	RF in Japan	100 M	—	24.9	66	—	—	4	—		657AN-1611 (green)
L2	OSC in Japan	100 M	—	17.9	69	—	—	5	—		657AN-1610BIT (black)
L2	RF2 in Eur. and U.S.A.	100 M	—	34.4	62	—	—	3	—		657AN-1591 (green)

(T) : TOKO Co., Ltd.

Pin connection (back view)

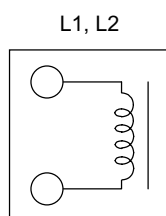

FM tuner module parts list for Eur. and U.S.A. band when variable coil is used.

No.	Ref No.	Product number	Specification	Remarks
1	IC1	TA2159F		
2	TR1	2SC4738		
3	TR2	2SC4738		
4	TR3	2SC4738		
5	TR4	2SA1832		
6	D1, D2	KV1780S	TOKO Co., Ltd.	Eur. and U.S.A.
7	L1 (Note)	5CBM 657AN-1608BIT	TOKO Co., Ltd.	BAND OSC
8	L2 (Note)	5CBM 657AN-1609	TOKO Co., Ltd.	BAND RF
9	L3	LLQ2012-E68NJ	TOKO Co., Ltd.	Eur. and U.S.A.
10	FL1	SFECS10M7FA00-B0	MURATA manufacturing Co., Ltd.	
11	X1	DT-261 75 kHz (9 pF)	Daishinku corp.	
12	X2	CDACV10M7GA116-B0	MURATA manufacturing Co., Ltd.	
13	JP1, 2, 3	MCR01MZSJ000	0 Ω ±5% 1005 model	Rohm · Other similar products can be usable
14	R4	MCR01MZSJ201	200 Ω ±5% 1005 model	Rohm · Other similar products can be usable
15	R10, 24	MCR01MZSJ102	1 kΩ ±5% 1005 model	Rohm · Other similar products can be usable
16	R11, 14, 17	MCR01MZSJ103	10 kΩ ±5% 1005 model	Rohm · Other similar products can be usable
17	R12	MCR01MZSJ104	100 kΩ ±5% 1005 model	Rohm · Other similar products can be usable
18	R3	MCR01MZSJ105	1 MΩ ±5% 1005 model	Rohm · Other similar products can be usable

No.	Ref No.	Product number	Specification	Remarks
19	R13	MCR01MZSJ106	10 M Ω \pm 5% 1005 model	Rohm · Other similar products can be usable
20	R18, 19	MCR01MZSJ153	15 k Ω \pm 5% 1005 model	Rohm · Other similar products can be usable
21	R5	MCR01MZSJ202	2 k Ω \pm 5% 1005 model	Rohm · Other similar products can be usable
22	R2	MCR01MZSJ223	22 k Ω \pm 5% 1005 model	Rohm · Other similar products can be usable
23	R20, 21	MCR01MZSJ303	30 k Ω \pm 5% 1005 model	Rohm · Other similar products can be usable
24	R15	MCR01MZSJ331	330 k Ω \pm 5% 1005 model	Rohm · Other similar products can be usable
25	R1, 9, 16, 23	MCR01MZSJ332	3.3 k Ω \pm 5% 1005 model	Rohm · Other similar products can be usable
26	R6	MCR01MZSJ391	390 Ω \pm 5% 1005 model	Rohm · Other similar products can be usable
27	R22	MCR01MZSJ471	470 Ω \pm 5% 1005 model	Rohm · Other similar products can be usable
28	C15, 26	CM05B333K16AH	0.033 μ F B K 16 V 1005 model	Kyocera · Other similar products can be usable
29	C27 (Note)	CM05CH050C50AH	5 pF CH J 50 V 1005 model	Kyocera · Other similar products can be usable
30	C30 (Note)	CM05CH030C50AH	3 pF CH J 50 V 1005 model	Kyocera · Other similar products can be usable
31	C35	CM05CH470J50AH	47 pF CH J 50 V 1005 model	Kyocera · Other similar products can be usable
32	C12, 13	CM05CH120J50AH	12 pF CH J 50 V 1005 model	Kyocera · Other similar products can be usable
33	C1, 2, 3, 10, 16	CM05W5R103K16AH	0.01 μ F W5R K 16 V 1005 model	Kyocera · Other similar products can be usable
34	C17, 18	CM05W5R153K16AH	0.015 μ F W5R K 16 V 1005 model	Kyocera · Other similar products can be usable
35	C23, 33	CM05W5R223K16AH	0.022 μ F W5R K 16 V 1005 model	Kyocera · Other similar products can be usable
36	C28, 29, 31, 32	CM05W5R272K50AH	2700 pF W5R K 50 V 1005 model	Kyocera · Other similar products can be usable
37	C24	CM05W5R331K50AH	330 pF W5R K 50 V 1005 model	Kyocera · Other similar products can be usable
38	C34	CM05W5R472K25AH	4700 pF W5R K 25 V 1005 model	Kyocera · Other similar products can be usable
39	C4, 5, 8, 21, 22	CM05Y5V104Z16AH	0.1 μ F Y5V Z 16 V 1005 model	Kyocera · Other similar products can be usable
40	C14	TMCMA0J226MTR	22 μ F M 6.3 V Case A	Kyocera · Other similar products can be usable
41	C7	TMCP0J105MTR	1 μ F M 6.3 V Case P	Kyocera · Other similar products can be usable
42	C6	TMCP0J106MTR	10 μ F M 6.3 V Case P	Kyocera · Other similar products can be usable
43	C9, 19, 20, 25	TMCP0J475MTR	4.7 μ F M 6.3 V Case P	Kyocera · Other similar products can be usable
44	Lead frame	180 (0.8)	1.8 mm-pitch	

Note:

1. Install JP2 and uninstall JP3 for Japan band.

7	L1	5CBM 657AN-1610BIT	TOKO Co., Ltd.	OSC for Japan band
8	L2	5CBM 657AN-1611	TOKO Co., Ltd.	RF for Japan band
28	C27	CM05CH010C50AH	1 pF CH J 50 V 1005 model	Kyocera · Other similar products can be usable
29	C30	CM05CH050C50AH	5 pF CH J 50 V 1005 model	Kyocera · Other similar products can be usable

2. OSC fixed coil version for Eur. and U.S.A. band (economy model)

7	L1	LLQ2012-E47NG	47nH 2012 model, TOKO Co., Ltd.	OSC for Eur. and U.S.A. band
8	L2	5CBM657AN-1591	TOKO Co., Ltd.	RF for Eur. and U.S.A. band
28	C27	CM05CH050C50AH	5 pF CH J 50 V 1005 model	Kyocera · Other similar products can be usable
29	C30	CM05CH050C50AH	5 pF CH J 50 V 1005 model	Kyocera · Other similar products can be usable

Example of Printed Circuit Board Pattern of FM tuner module (top view)

This module consists of four layers of PCB. The first and the fourth layers are shown here.

Figure of PCB with parts mounted

IC-mounted side

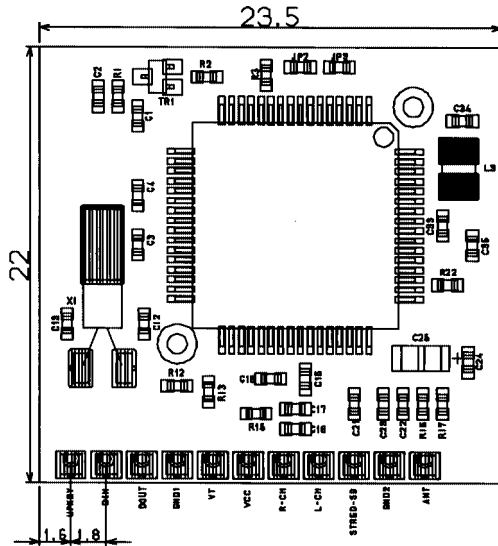

Chip-mounted side

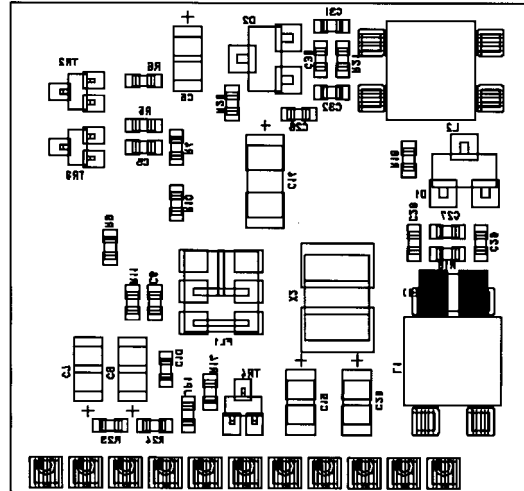

Pattern layout

IC-mounted side

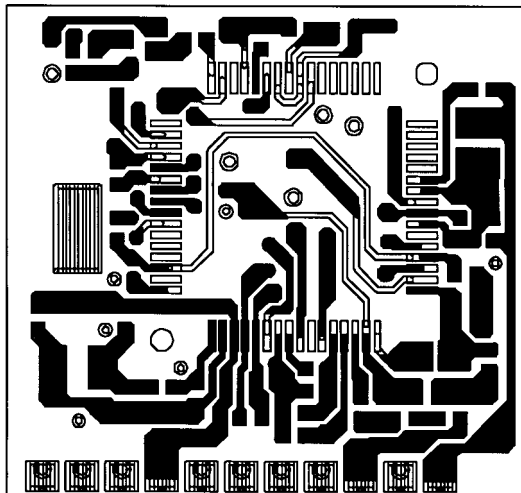

Chip-mounted side

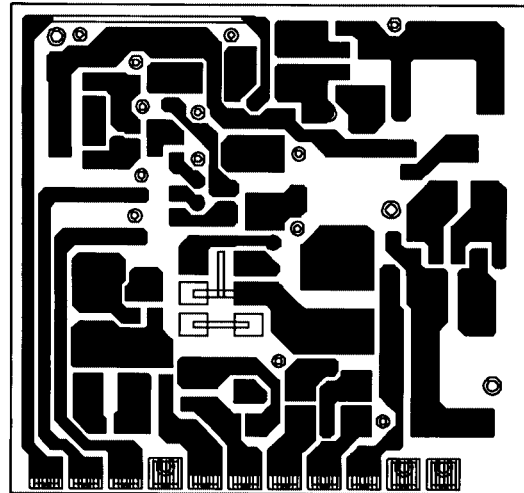

FM tuner characteristic data

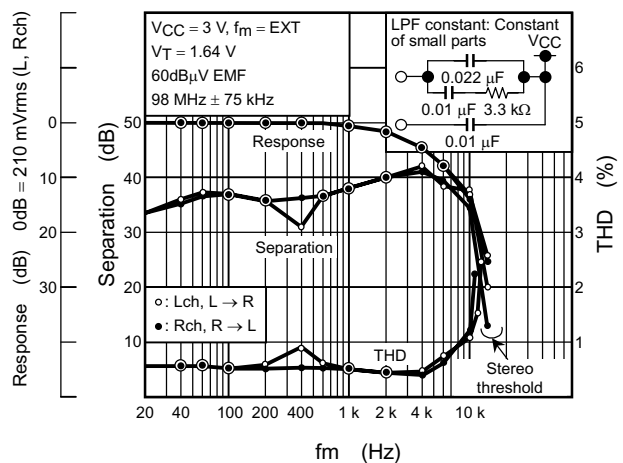
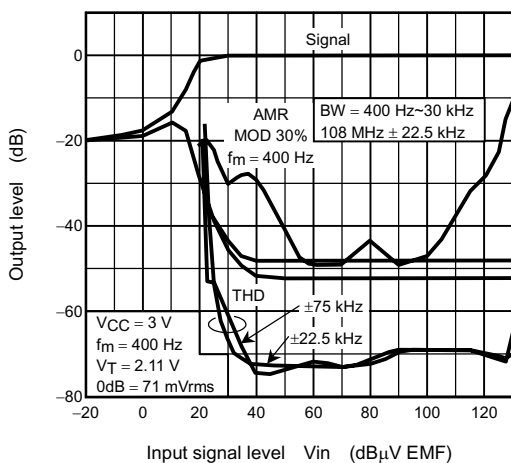
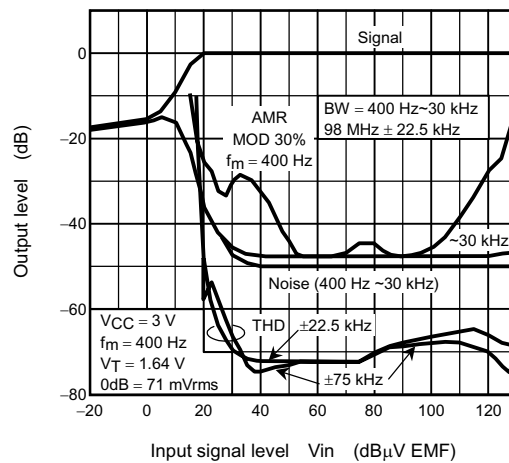
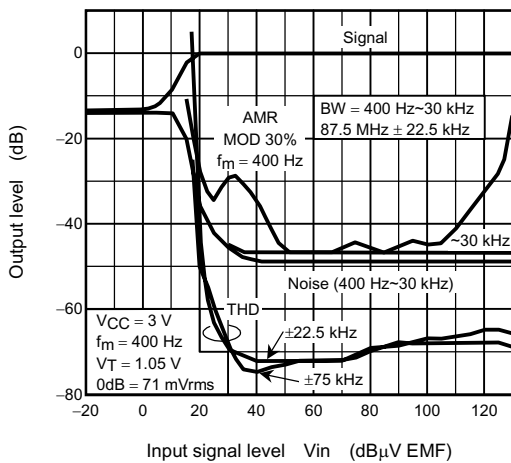
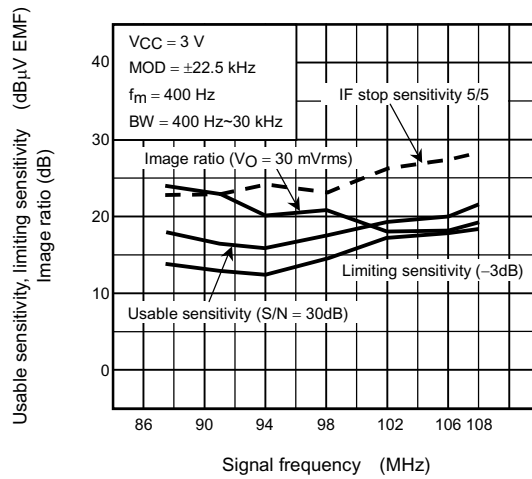
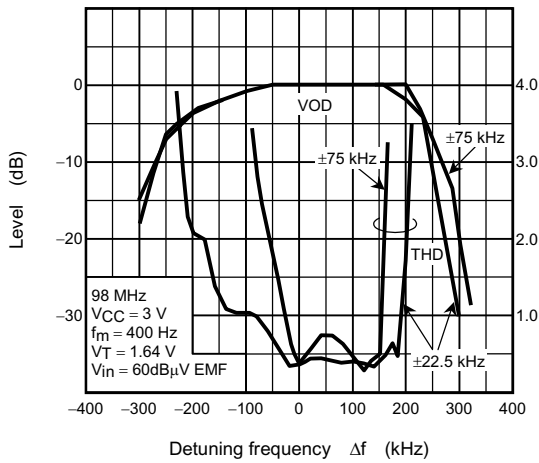

Software Specifications

Precautions

- Please refer the Setting Formats on the TA2159F data sheet.
- Control software in C language is provided free of charge, but operations cannot be guaranteed, and technical support cannot be provided.
- The operation is guaranteed and technical support is provided only when Toshiba's microcontroller is used.

1. Main Features	11
1.1 Function (1): Power ON/OFF	12
1.2 Function (2): 1 Step Up	12
1.3 Function (3): UP Searching	12
1.4 Function (4): Memory Scan	12
1.5 Function (5): Memory Reading	12
1.6 Function (6): Frequency Loading	12
1.7 Function (7): LCD Display	12
1.8 Function (8): UART Controlling	12
1.9 Function (9): BAND Controlling in Japan/other countries	12
2. System Overview	13
3. Description of Modules	14
3.1 System Management Module	14
3.1.1 RAM configuration	14
3.1.2 System Management Module Initializing	15
3.1.3 System Operation Mode Management	15
3.1.4 Timer Interrupt	15
3.1.5 System Management Module Flow Diagrams	15
3.2 Tuner Control Module	17
3.2.1 RAM configuration	17
3.2.2 Tuner Control Module Initializing Process	18
3.2.3 Tuner Communication Control Process	18
3.2.4 Data Transmission Interrupt Process	18
3.2.5 Data Reception Interrupt Process	18
3.2.6 Tuner Control Module Flow Diagrams	18
3.3 Key Control Module	20
3.3.1 RAM configuration	20
3.3.2 Key Control Module Initializing Process	20
3.3.3 Key Scan Process	20
3.3.4 Key Decoding Process	20
3.3.5 Key Control Module Flow Diagrams	21
3.4 Display Control Module	22
3.4.1 RAM configuration	22

3.4.2	Initializing Display Control Module	22
3.4.3	Display Mode Management Process.....	22
3.4.4	Display Control Module Flow Diagram	23
3.5	LCD Driver Module	24
3.5.1	LCD Driver Module Initialization Process.....	25
3.5.2	LCD Display Data Transfer Process.....	25
3.5.3	LCD Driver Module Flow Diagram.....	26

1. Main Features

- Application TA2159 Tuner Controller Reference Model
- MCU TMP91CW12F
- Program Language C Language

- Function
- (1) Power ON/OFF
- (2) One Step UP
- (3) UP Searching
- (4) Memory Scan (up to 20 stations)
- (5) Memory Reading
- (6) Frequency Loading
- (7) LCD Display
- (8) UART Controlling
- (9) BAND Controlling in Japan/other countries

1.1 Function (1): Power ON/OFF

Switches ON/OFF whenever the Power Key is pressed once.

ON → Sets the saved status.

OFF → Saves the status when the Power Key was switched OFF.

(During the UP Search and the Memory Scan, saves the settings of when those functions were started.)

1.2 Function (2): 1 Step Up

Receiver frequency goes up one step whenever the UP Key is pressed once.

1.3 Function (3): UP Searching

Searches a receiving station when the UP Key is pressed for longer than 500 ms.

If a key input is applied during the Search, returns to the status of when the Search was started.

1.4 Function (4): Memory Scan

Holding the Memory Key down and pressing the UP Key twice start the Memory Scan at the current receiving station.

When 20 stations (max) are entered into the Memory, or Memory Scan is returned to the starting receiving station, completes Memory Scan.

If a key input is applied during the Memory Scan, returns to the status of when the Memory Scan was started.

1.5 Function (5): Memory Reading

Reads out receiving stations in the Memory whenever the Memory Key is pressed once.

1.6 Function (6): Frequency Loading

Loads frequency of the current receiving station from the FM tuner module whenever the Load Key is pressed once.

1.7 Function (7): LCD Display

Shows "FM" and "receiver frequency" on a display at power on, "MEMO" and "station numbers in memory (up to 20 stations)" at Memory reading, "SEEK" at the UP Search and the Memory Scan, and "st" when receives STEREO signals from the tuner.

1.8 Function (8): UART Controlling

Uses UART (data transmission rate: 1200 bps) to communicate with the FM tuner module, and transmits/receives commands, frequency to be set, and frequency that the tuner has received.

1.9 Function (9): BAND Controlling in Japan/other countries

Checks High-/Low-input of BAND switch at power on, and determines the minimum and the maximum frequencies, and frequency step width of BAND in Japan/other countries.

BAND in Japan: 76.00 to 90.00 MHz (100-kHz step)

BAND in other countries: 87.50 to 108.00 MHz (50-kHz step)

2. System Overview

The TMP91CW12F consists of System Management Module, Tuner Control Module, Key Control Module, Display Control Module, and LCD Driver Module.

Module Name	Process Description
System Management Module (Sos.c)	System Management Module initializing process System Operation Mode management process Timer interrupt (INTTA1) process: 5 ms
Tuner Control Module (Tuner.c)	Tuner Control Module initializing process Tuner communication control process Data transmission interrupt (INTTX0) process Data reception interrupt (INTRX0) process
Key Control Module (Key.c)	Key Control Module initializing process Key scan (INTTA0) process: 2 [ms] Key decoding process
Display Control Module (Display.c)	Display Control Module initializing process Display Mode management process
LCD Driver Module (LcdDriver.c)	LCD Driver Module initializing process LCD display data transmission process

The followings are the TMP91CW12F system configuration.

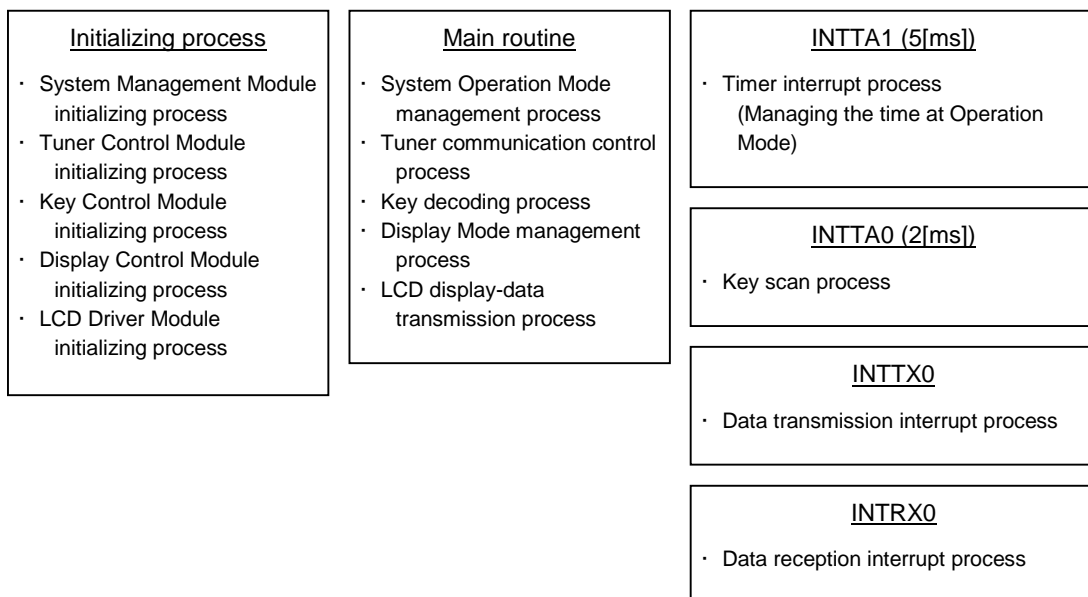

3. Description of Modules

3.1 System Management Module

This Module consists of System Management Module initializing process, System Operation Mode management process, and timer interrupt (INTTA1) process that manages time to be used at Operation Mode.

Note: Source file = Sos.c, Sos.h.

3.1.1 RAM configuration

The following RAM chips are used in this module.

Name	Data Length (byte)	Contents
gSosMode	1	Operation Mode
gSosModeSave	1	Saves the operation Mode temporarily
gSosFrequData	2	Frequency data
gSosFrequLowEnd	2	Minimum frequency data
gSosFrequHightEnd	2	Maximum frequency data
gSosFrequStep	1	Frequency data per one stepwidth
gSosMemNumMax	1	Number of all receiving stations in memory
gSosMemNumIndex	1	Receiving station numbers
gSosMemNumIndexSave	1	Saves the receiving station numbers temporarily
gSosFlashCnt	1	Display flashing timer counter
gSosTunerCmdTimer	1	Timer counter for disabling command transmission to the tuner
gSosActInitMode	1	Internal Operation Mode in Initial Mode
gSosUpStepMode	1	Internal Operation Mode in Up Step Mode
gSosUpScanMode	1	Internal Operation Mode in Up Scan Mode
gSosScanStopMode	1	Internal Operation Mode in Stop Mode
gSosLoadMode	1	Internal Operation Mode in Frequency Data Loading Mode
gSosMemorySetMode	1	Internal Operation Mode in the Memory Set Mode
gSosMemoryScanMode	1	Internal Operation Mode in the Memory Scan Mode
gSosMSStartFrequ	2	Frequency when the Memory Scan is started
gSosMSJudgeFrequ	2	Compared frequency to check completion of the Memory Scan (For detecting that the Scan has lapped around from the selected frequency to the one immediately before that.)
gSosMSJudge	1	Branch conditions for checking completion of Memory Scan
gSosMSJudgeEnd	1	Indicates the Memory Scan has been lapped around from the selected frequency to the one immediately before that.
gSosMSJudgeStop	1	Indicates the Memory Scan lapped around from the selected frequency to the one immediately before that.
gSosCallModeSave	1	Operation Mode for recovering in case of a key input during the Up Scan and the Memory Scan (saved temporarily)
gSosTunerCtrlMode	1	Internal operation Mode in Tuner command and frequency setting Mode
gSosTunerCtrlResult	1	Result message from Tuner Control Module
gSosTunerCtrlCmdData	1	Tuner control command data
gSosTunerCtrlCmdMem	1	Saves the tuner control command data temporarily
gSosTunerCtrlFrequData	2	Frequency data transferred to/received from Tuner Control Module
gSaveData	10	Saves the settings: Operation Mode, Receiving station numbers, Number of all receiving stations in Memory, Receiver frequency, Minimum frequency, Maximum frequency, Frequency data every one step
gSaveMemoryFrequ	40	Frequency of receiving station in Memory (up to 20 stations)

3.1.2 System Management Module Initializing

Initialize variables, ports, and timer interrupting used in System Management Module.

3.1.3 System Operation Mode Management

The TMP91CW12F receives Key data input from Key Controlling Module, and changes the system operation mode from Memory Mode to Normal Mode according to the information about operation modes, Key data, and measured time. The messages for operations of Tuner Control Module and Display Module are determined.

The followings are the operation modes in System Operation Mode management process.

Operation Mode	Mode Management Process
Power OFF Mode	Saves current settings. Display is OFF.
Normal Mode	Shows receiver frequency. Waits a Key input.
Up Step Mode	Receiver frequency goes up one step.
Memory Mode	Reads out station numbers in memory. Shows station numbers in memory and receiver frequency. Waits a Key input.
Memory Setting Mode	Sets the station numbers in memory.
Frequency Loading Mode	Loads frequency of the tuner
Up Scan Mode	Executes Up Search and displays "Seek". Waits a Key input.
Memory Scan Mode	Displays Memory Scan and Memory Seek. Waits a Key input.
Initial Mode	Reads out the saved settings. Display is ON
Tuner Frequency Setting Mode	Sets receiver frequency for Tuner Control Module.
Tuner Command Setting Mode	Sets commands for Tuner Control Module.
Stop Mode	Sets frequency for receiving, and stops the tuner.

3.1.4 Timer Interrupt

Performs flashing-count of the display, and the timer count to check the completion of Up Scan and Memory Scan by generating interrupt every 5-ms cycle. Based on those counted data, the TMP91CW12F controls ON/OFF for display flashing and permission/prohibition of transferring messages to Tuner Control Module in System Operation Mode management process.

3.1.5 System Management Module Flow Diagrams

Initializing System Management Module

<Sos.c: Sos_Init function>

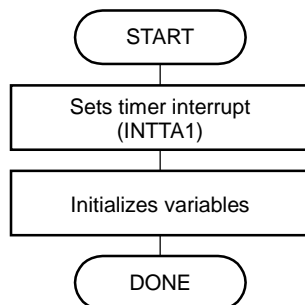

System Operation Modes Management

<Sos.c: Sos_Main function>

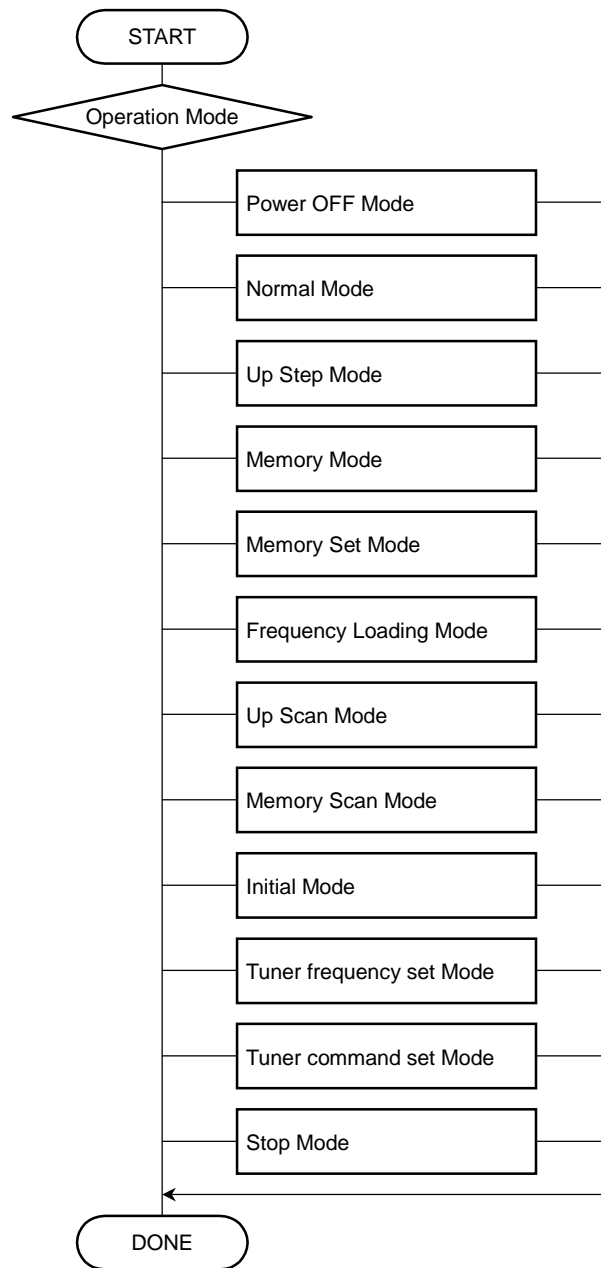

Timer Interrupt

<Sos.c: INTTA1 function>

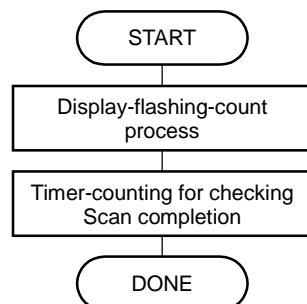

3.2 Tuner Control Module

This Module consists of Tuner Control Module initializing process, tuner communication control process, data transferring interrupt (INTTX0) process and data receiving interrupt (INTRX0) process.

Note: Source file = Tuner.c, Tuner.h

3.2.1 RAM configuration

The following RAM chips are used in this module.

Name	Data Length (byte)	Contents
gTunerMsgReceive	3	Messages that Tuner Control Module received from other modules : Tuner control receiving command, Determined frequency
gTunerMsgSend	4	Messages that Tuner Control Module transfers to other modules : Tuner control transferring command, Frequency received from the tuner, Statuses
gTunerMode	1	Tuner Control Mode
gUartMode	1	UART Operation Mode
gTunerTimeOutCnt	2	Tuner control time-out counter
gTunerOutDataCnt	1	Transferring data counter to the tuner
gTunerDataIndex	1	Data Index of communication (transferring /receiving data)
gTunerData	5	Communication (transferring/receiving data) data buffer
gTunerWork	2	Frequency conversion working area
gTunerBANDsw	1	Scan data of BAND switch
gTunerBANDswBackup	1	Data to compare the changes of BAND switch
gTunerBANDswChataCnt	1	BAND sw Scan, chatter elimination counter
gTunerBANDLowEnd	2	The minimum frequency
gTunerBANDHighEnd	2	The maximum frequency
gTunerFrequStep	1	Frequency data per one stepwidth

3.2.2 Tuner Control Module Initializing Process

Initializes variables, ports, and transferring/receiving UART used in Tuner Control Module. Also, checks the BAND switch that selects BAND for Japan/other countries, and sets the minimum/maximum frequencies, and frequency stepwidth.

3.2.3 Tuner Communication Control Process

Receives messages to control the tuner from System Operation Mode Management Module, and transfers control commands to the tuner. Determines messages for System Operation Mode Management Module by the received data.

3.2.4 Data Transmission Interrupt Process

When there is data to transfer, it is transferred to a transfer buffer. After all the data was transferred, permits receiving data.

3.2.5 Data Reception Interrupt Process

Checks validity of received data. When there is data to receive, it is saved in a receive data buffer. After all the data was received, prohibits receiving data.

3.2.6 Tuner Control Module Flow Diagrams

Tuner Control Module Initializing Process

<Tuner.c: Tuner_Init function>

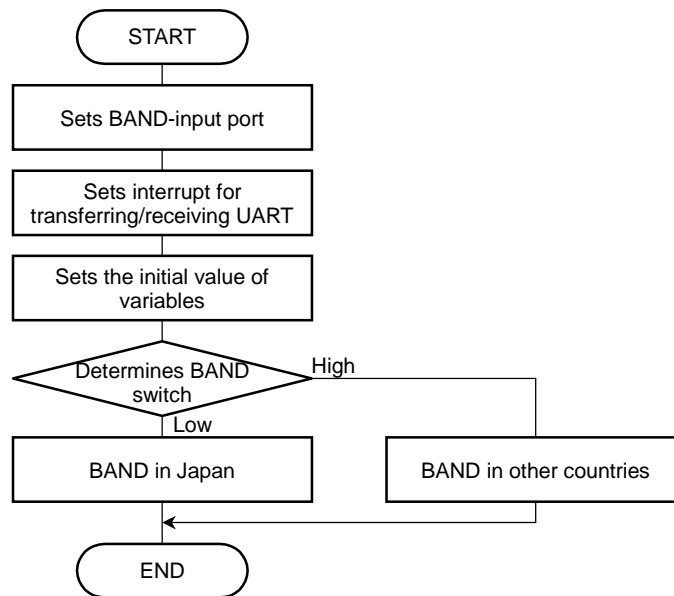

Tuner Communication Control Process

<Tuner.c: Tuner_Main function>

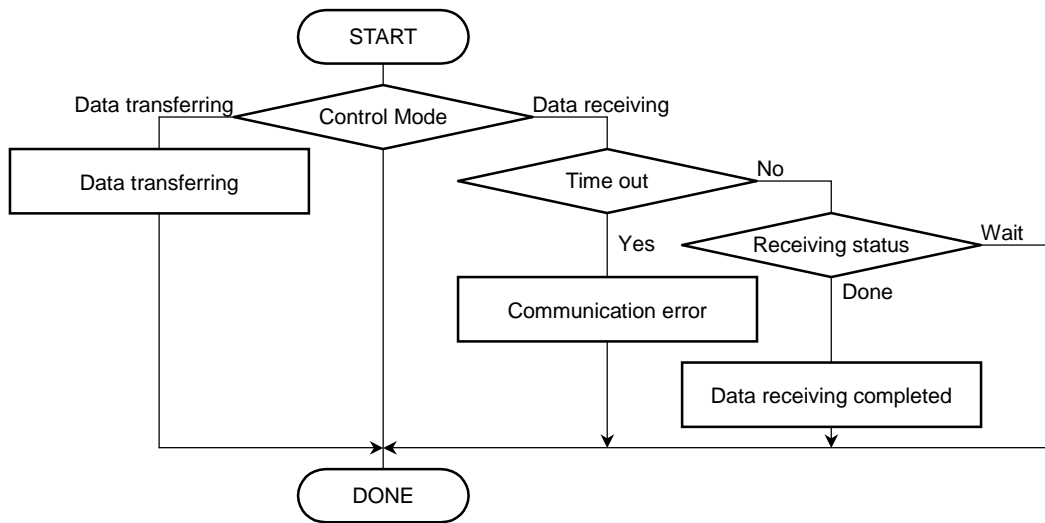

Data transmission interrupt process

<Tuner.c: INTTX0 function>

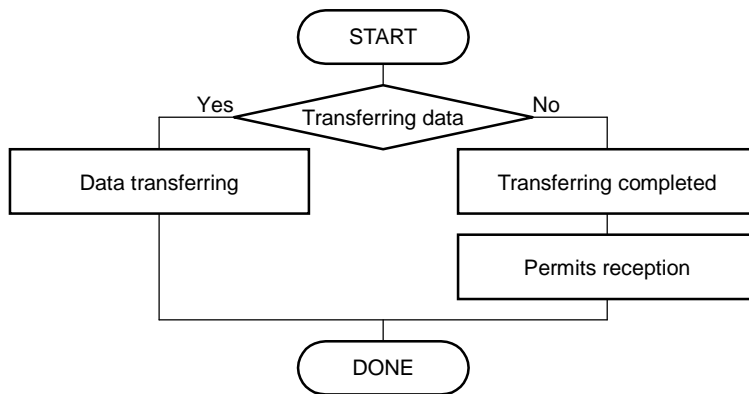

Data reception interrupt process

<Tuner.c: INTRX0 function>

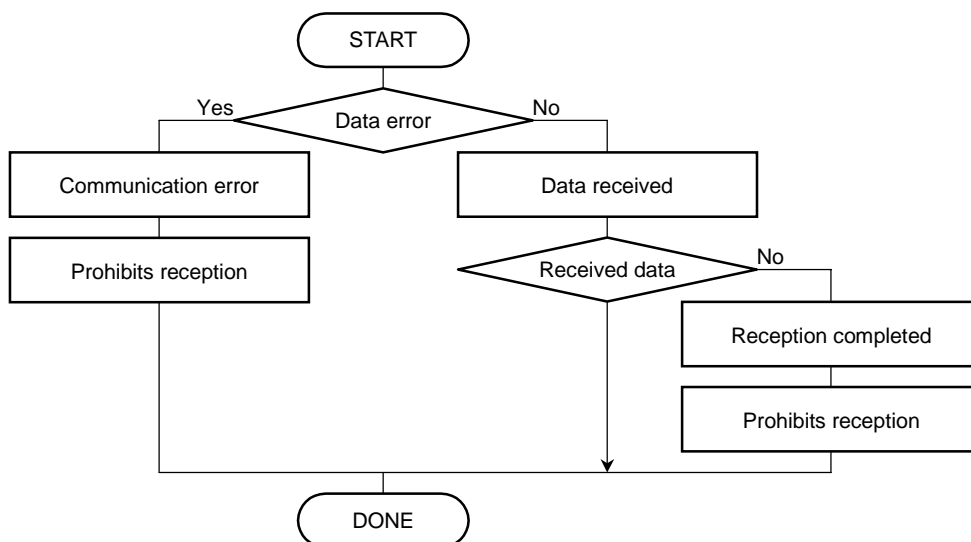

3.3 Key Control Module

This Module consists of Key Control Module initializing process, Key scan(INTTA0)process, and Key decoding process.

Note: Source file = Key.c, Key.h

3.3.1 RAM configuration

The following RAM chips are used in this module.

Name	Data Length (byte)	Contents
gKeyScan	1	Scan data of Key input
gKeyScanBackup	1	Data for comparing the changes of Key input
gKeyChataCnt	1	Chatter elimination counter in Key Scan process
gKeyPushCnt	1	Counts up while the key is held down in Key Scan process
gKeyDecode	1	Key decoded data
gKeyData	1	Key confirmed data
gStereoSignal	1	Scan data of stereo signals
gStereoSignalBackup	1	Data for comparing the changes of stereo signals
gStereoSignalChataCnt	1	Chatter elimination counter for stereo signals

3.3.2 Key Control Module Initializing Process

Initializing variables, ports, and timer interrupts used in Key Control Module.

3.3.3 Key Scan Process

Timer interrupt is generated every 2-ms cycle, and Key scan data is read out from a port connected to the Key. The Key scan data executes chatter elimination for about 30-ms, and fixes the Key scan data. If the scan data does not change after it was fixed, counts up how long the key is held down.

3.3.4 Key Decoding Process

Receives Key scan data through the input from Key scan process, and decodes it to Key data. Basically, the Key data input is accepted when the Key was released. As an exception, the Key data is accepted when Up Scan is executed while Up Key is pressed for 500 ms, and decodes inputs through pressing Memory Key and Up Key at the same time as Memory Scan.

3.3.5 Key Control Module Flow Diagrams

Key Control Module Initializing Process

<Key.c: Key_Init function>

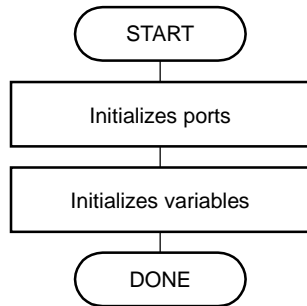

Key Scan Process

<Key.c: INTTA0 function>

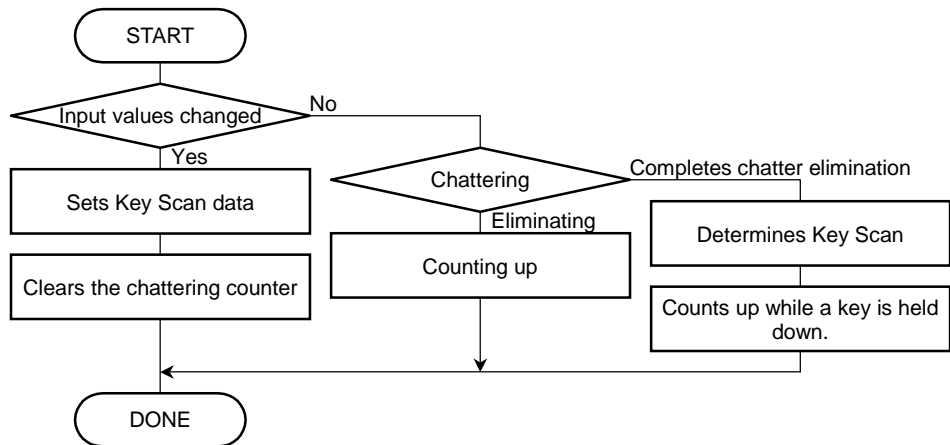

Key Decoding Process

<Key.c: Key_Main function>

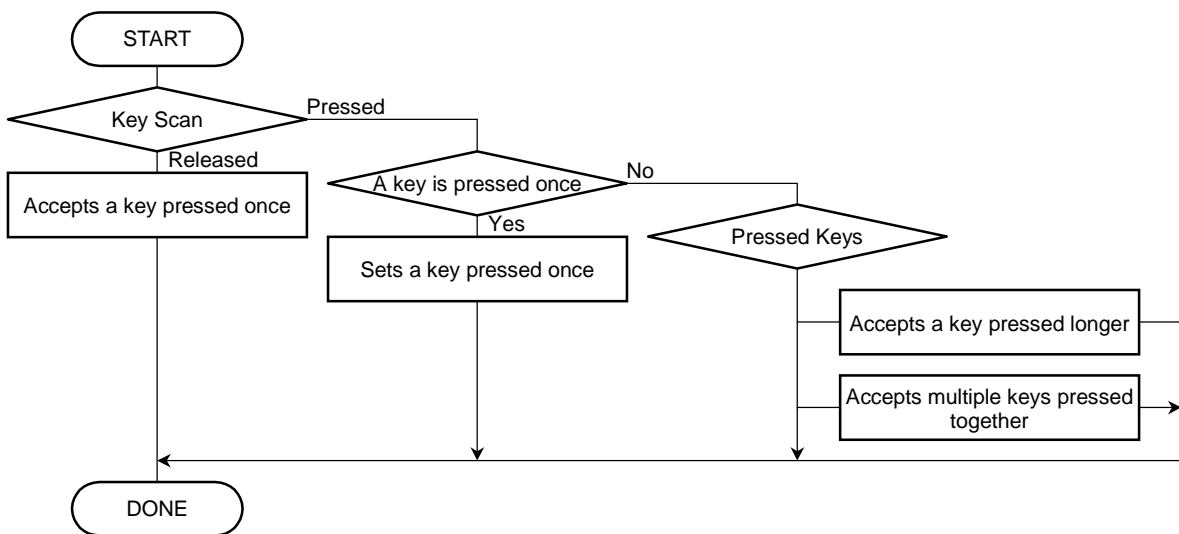

3.4 Display Control Module

This Module consists of Display Control Module initializing process, and Display Mode management process.

Note: Source file = Display.c, Display.h

3.4.1 RAM configuration

The following RAM chips are used in this module.

Name	Data Length (byte)	Contents
gDispMsg	5	Messages that Display Control Module receives from other Modules. : Display Control Mode, Frequency, Receiving station numbers, Display ON/OFF
gDisp_workspace	6	Working area for creating display data
gDispDisplayCondi	1	Managing ON/OFF status for display

3.4.2 Initializing Display Control Module

Initializing variables, ports, LCD driver, LCD functions, and interfaces used in Display Control Module.

3.4.3 Display Mode Management Process

Receives messages that control a display through System Operation Mode Management Module. Creates display data according to Display Mode, and uses the LCD driver to show the indications on a display.

The followings are Display Modes managed in Display Mode management process.

Display Mode	Process Description
Power-OFF Mode	LCD is OFF, and clears contents shown on a display.
Normal Mode	Shows "FM" and "receiver frequency" on a display.
Up Step Mode	Clears "Blank" shown on a display.
Frequency Loading Mode	Clears "Blank" shown on a display.
Memory Display Mode	Shows "FM", "MEMO", "receiving station numbers", and "receiver frequency" on a display.
Up Search Mode	Shows "Seek" on a display or clears "Blank" shown on a display.
Memory Search Mode	Shows "MEMO" and "Seek" on a display or clears "MEMO" and "Blank", and "receiving station numbers" shown on a display.
Initial Mode	LCD is ON.
Display Clear Mode	Shows "FM" on a display. Clears "MEMO", "receiving station numbers", and "Blank" shown on a display.

3.4.4 Display Control Module Flow Diagram

Display Control Module Initializing Process

<Display.c: Disp_Init function>

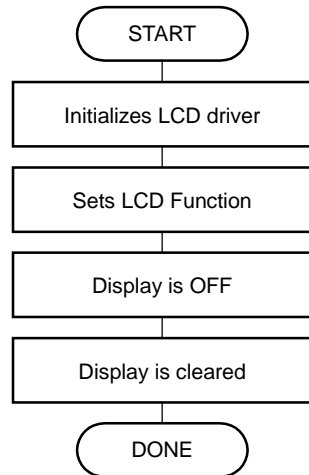

Display Mode Management Process

<Display.c: Disp_Main function>

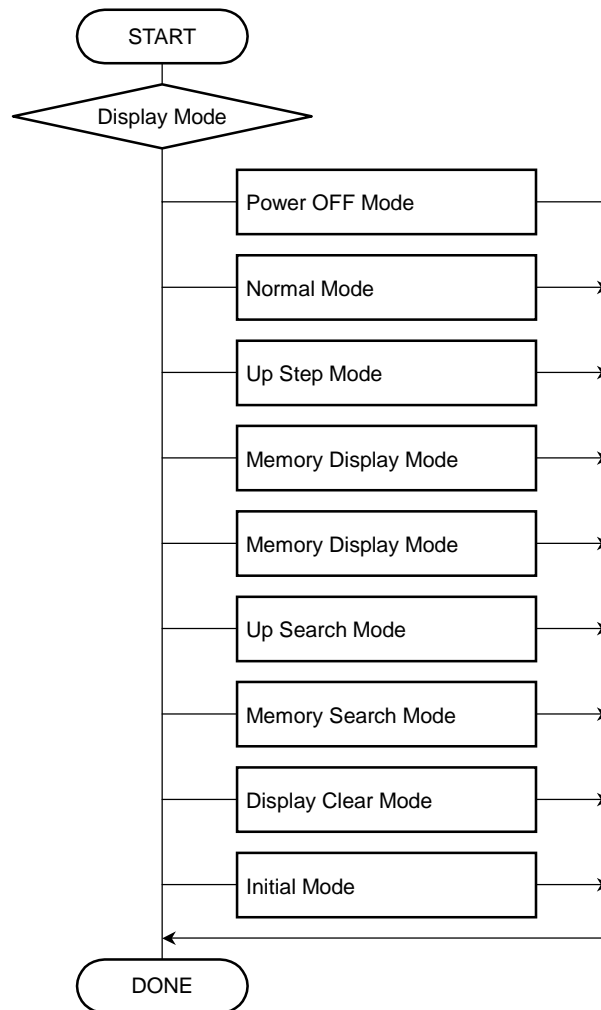

3.5 LCD Driver Module

This Module consists of LCD Driver Module initializing process and LCD display data transfer process to drive HITACHI HD44780U (LCD-II).

Note: Source file = LcdDriver.c, LcdDriver.h

This Module is created to support controlling both port and BUS to control LCD.

(Note: Information about BUS controlling is described for the purpose of reference.)

Defining Access Mode in a header file of LCD driver (LcdDriver.h) as "Bus Access" or "Port Access" enables to switch the port control to the BUS control.

Use the same methods to control the port and BUS as the one to set the jumper on a PCB. For the details about LCD, please see the HD44780U (LCD- α) data sheet.

<Definitions of controlling methods>

```
#define PortAccess 0 Port accessing to LCD
```

```
#define BusAccess 1 Bus accessing to LCD
```

<Selecting a method to access to LCD>

```
#define AccessMode PortAccess (Here, the port control is selected.)
```

```
#if AccessMode
```

```
[BUS controlling is set]
```

```
(Note: Define RAM for accessing LCD at address 0x20000.)
```

```
#else
```

```
[Port controlling is set]
```

```
#endif
```

3.5.1 LCD Driver Module Initialization Process

In LCD Driver Module Initializing process, related registers, ports, and variables are initialized. Also, there are modules to set functions and interfaces for LCD settings, and the modules are used to set LCD formats.

The followings are modules in LCD Driver Module initializing process.

Module Name	Process Description
LCD driver initializing process	Initializes the related registers, ports, and variables.
Display clearing process	After clearing all displays, sets address zero of DDRAM to the address counter.
Cursor home process	Sets address zero of DDRAM to the address counter. (A shifted display is returned. The contents of DDRAM are not changed.)
Entry Mode setting process	Sets directions of a cursor, and shift/not shift the display. (This settings are executed when data is written or read out.)
Display OFF process	Turns a display OFF
Display ON process	Turns a display ON, a cursor ON/OFF, and sets blinking characters at the cursor
Cursor/display shifting process	Sets movements of a cursor and a display shifting without changing the contents of DDRAM.
Functions setting process	Sets interface data length, lines per display, and fonts.

3.5.2 LCD Display Data Transfer Process

In this process, data is written to LCD and read out from LCD using several modules. The followings are the Modules used in LCD Display Data Transfer Process.

Module Name	Process Description
CGRAM Write process	Writes successive data in CGRAM.
CGRAM Read process	Reads successive data from CGRAM.
DDRAM Write process	Writes successive data in DDRAM.
DDRAM Read process	Reads successive data from DDRAM.

3.5.3 LCD Driver Module Flow Diagram

LCD Driver Initializing Process

<LcdDriver.c: LcdDriver_Init function>

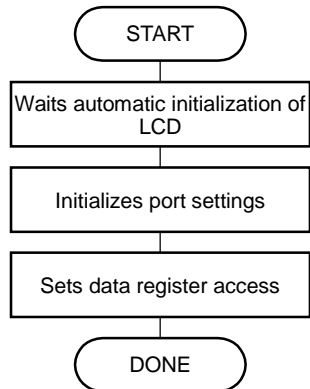

Display Clear Process

<LcdDriver.c: LcdDrvClearDisplay function>

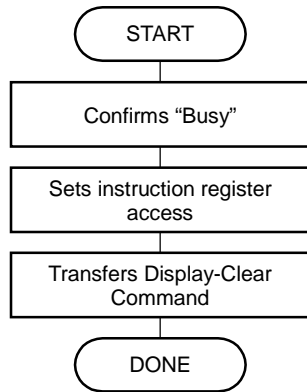

Cursor Home Process

<LcdDriver.c: LcdDrvReturnHome function>

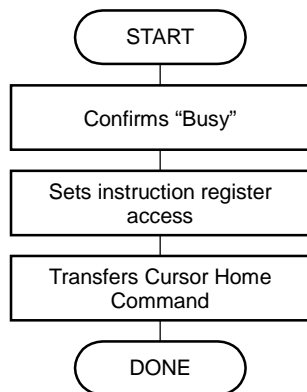

Entry Mode Setting Process

<LcdDriver.c: LcdDrvEntryModeSet function>

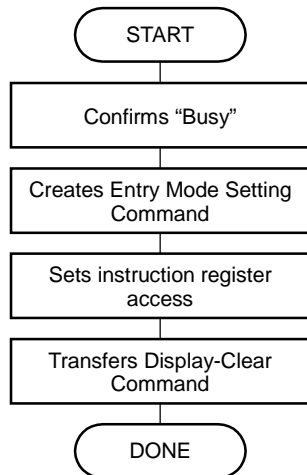

Display OFF Process

<LcdDriver.c: LcdDrvDisplayOFFControl function>

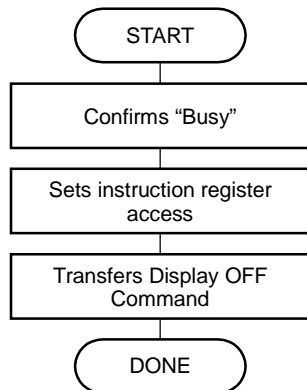

Display ON Process

<LcdDriver.c: LcdDrvDisplayONControl function>

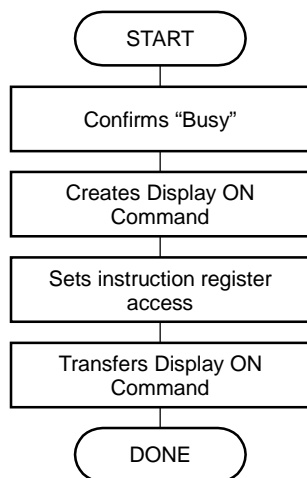

Cursor/Display Shifting Process

<LcdDriver.c: LcdDrvCursorDisplayShift function>

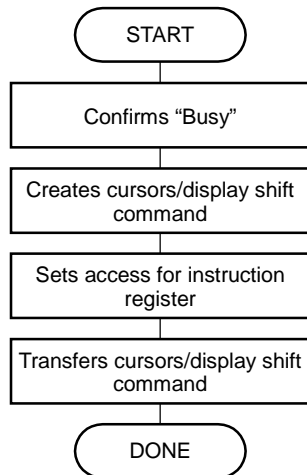

Functions Setting Process

<LcdDriver.c: LcdDrvFunctionSet function>

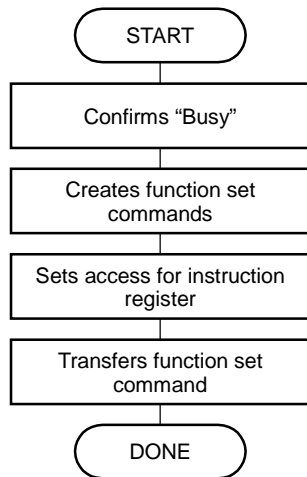

Write CGRAM Process

<LcdDriver.c: LcdDrvWriteCGRAM function>

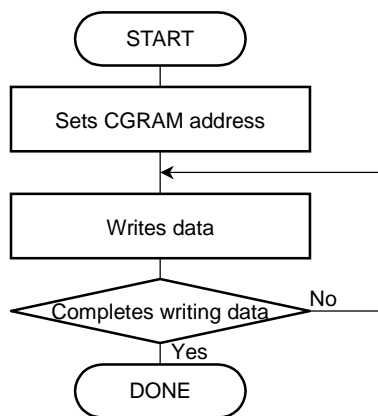

Read CGRAM Process

<LcdDriver.c: LcdDrvReadCGRAM function>

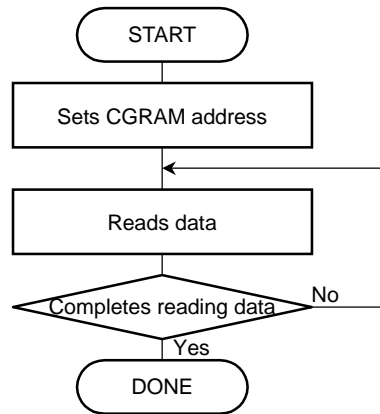

Write DDRAM Process

<LcdDriver.c: LcdDrvWriteDDRAM function>

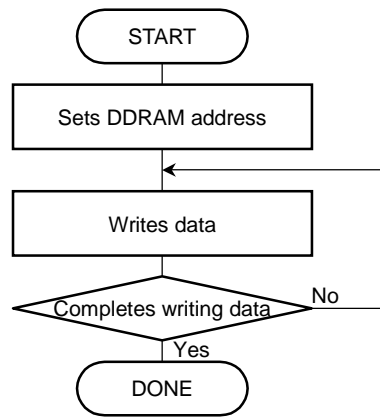

Read DDRAM Process

<LcdDriver.c: LcdDrvReadDDRAM function>

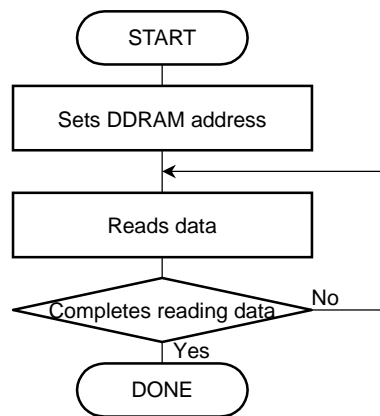

RESTRICTIONS ON PRODUCT USE

000707EBA

- TOSHIBA is continually working to improve the quality and reliability of its products. Nevertheless, semiconductor devices in general can malfunction or fail due to their inherent electrical sensitivity and vulnerability to physical stress. It is the responsibility of the buyer, when utilizing TOSHIBA products, to comply with the standards of safety in making a safe design for the entire system, and to avoid situations in which a malfunction or failure of such TOSHIBA products could cause loss of human life, bodily injury or damage to property.
In developing your designs, please ensure that TOSHIBA products are used within specified operating ranges as set forth in the most recent TOSHIBA products specifications. Also, please keep in mind the precautions and conditions set forth in the "Handling Guide for Semiconductor Devices," or "TOSHIBA Semiconductor Reliability Handbook" etc..
- The TOSHIBA products listed in this document are intended for usage in general electronics applications (computer, personal equipment, office equipment, measuring equipment, industrial robotics, domestic appliances, etc.). These TOSHIBA products are neither intended nor warranted for usage in equipment that requires extraordinarily high quality and/or reliability or a malfunction or failure of which may cause loss of human life or bodily injury ("Unintended Usage"). Unintended Usage include atomic energy control instruments, airplane or spaceship instruments, transportation instruments, traffic signal instruments, combustion control instruments, medical instruments, all types of safety devices, etc.. Unintended Usage of TOSHIBA products listed in this document shall be made at the customer's own risk.
- The products described in this document are subject to the foreign exchange and foreign trade laws.
- The information contained herein is presented only as a guide for the applications of our products. No responsibility is assumed by TOSHIBA CORPORATION for any infringements of intellectual property or other rights of the third parties which may result from its use. No license is granted by implication or otherwise under any intellectual property or other rights of TOSHIBA CORPORATION or others.
- The information contained herein is subject to change without notice.

This datasheet has been download from:

www.datasheetcatalog.com

Datasheets for electronics components.