

AN8090, AN8090S

Overvoltage Protective Circuits Built-in Switching Power Supply

Overview

The AN8090 and the AN8090S enables high-speed control up to 500 kHz and have various protective functions for over-current, overvoltage, and thermal protection in order to improve reliability of the power supply.

Features

- 500 kHz PWM control frequency and miniaturized
- Capable of directly driving the large-capacity MOS FET
- Provided with 2-channel overcurrent protective function for positive side and negative side, and intermittent operating function as protection when an over-current state advanced further
- Provided with over-voltage protective and over-heat protective functions
- Provided with the ON/OFF function to start/stop operating the power supply with external signals and the error amplifier required for secondary control
- 16-DIP package for the AN8090 and SONF-20D for the AN8090S

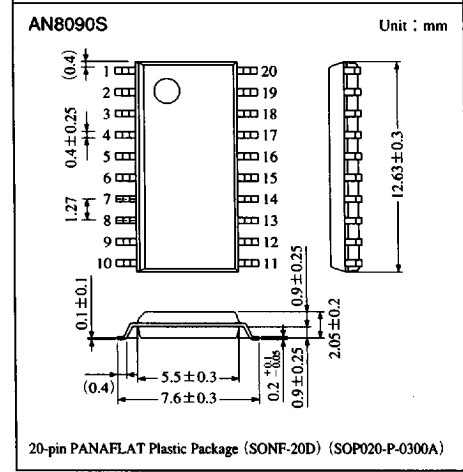
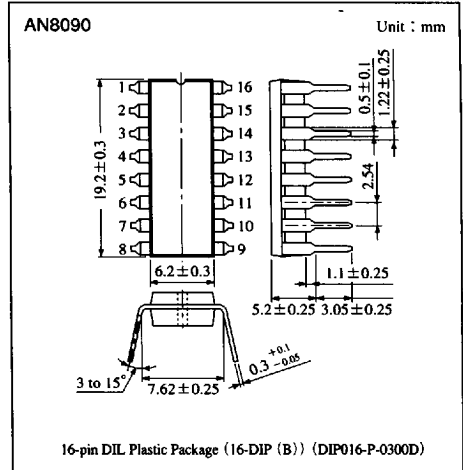

Block Diagram

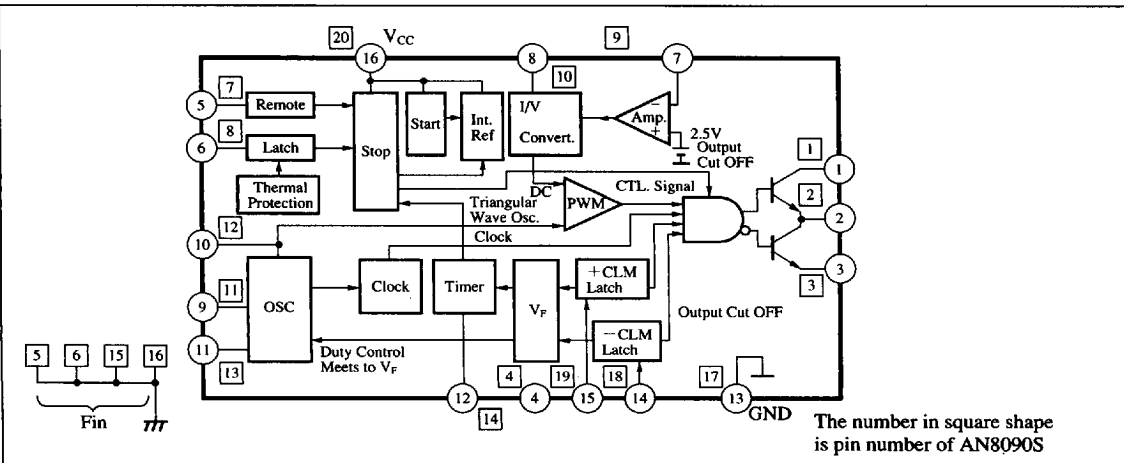

6932852 0012772 171

■ Absolute Maximum Ratings (Ta=25°C)

Parameter	Symbol	Rating	Unit
Supply voltage	V _{CC}	35	V
Peak output current	I _{O(peak)}	±2	A
Maximum continuous output current	I _{O(max.)}	±0.15	A
Power dissipation	P _D	1.5 *	W
Operating ambient temperature	T _{opr}	-30 to +85	°C
Storage temperature	AN8090	-55 to +150	°C
	AN8090S	-40 to +125	

* For the AN8090S, Ta ≤ 25°C when mounting onto the glass epoxy substrate (substrate size = 5cm × 5cm × 0.45cm)

■ Recommended Operating Range (Ta=25°C)

Parameter	Symbol	Range
Operating supply voltage range	V _{CC}	Stop voltage to 34V

■ Electrical Characteristics (Ta=25°C)

Parameter	Symbol	Condition	min	typ	max	Unit
Operating voltage range	V _{CC}		—	—	34	V
Start voltage	V _{CC(start)}		15.2	16	17.2	V
Stop voltage	V _{CC(stop)}		9	10	10.9	V
Start/stop voltage difference	ΔV _{CC}	ΔV _{CC} = V _{CC(start)} - V _{CC(stop)}	5	6	7	V
Prestart circuit current	I _{CCL}	V _{CC} = 14.5V Ta = 25°C	50	80	120	μA
		V _{CC} = 14.5V -30°C ≤ Ta ≤ 85°C	40	80	160	μA
Circuit current	I _{CCO}	V _{CC} = 30V	10	15	21	mA
ON/OFF pin H threshold voltage	V _{TH ON/OFF}		2.1	2.6	3.1	V
ON/OFF pin L threshold voltage	V _{TL ON/OFF}		1.9	2.4	2.9	V
ON/OFF pin hysteresis voltage	ΔV _{T ON/OFF}		0.1	0.2	0.3	V
Oscillation frequency	f _{OSC}	R1 = 17kΩ, R2 = 22kΩ, CF = 220pF	180	200	220	kHz
Duty ratio	Γ _{DUTY}	R1 = 17kΩ, R2 = 22kΩ, CF = 220pF	45	48	51	%
Oscillation waveform upper limit voltage	V _{OSCH}		4	4.4	4.8	V
Oscillation waveform lower limit voltage	V _{OSCL}		1.8	2	2.2	V
Oscillation waveform upper/lower limit voltage difference	ΔV _{OSC}		2.1	2.4	2.7	V
Output low voltage	V _{OL1}	V _{CC} = 18V, I _O = 10mA	—	0.05	0.4	V
	V _{OL2}	V _{CC} = 18V, I _O = 100mA	—	0.7	1.4	V
	V _{OL3}	V _{CC} = 5V, I _O = 10mA	—	0.69	1	V
	V _{OL4}	V _{CC} = 5V, I _O = 100mA	—	1.3	2	V
Output high voltage	V _{OH1}	V _{CC} = 18V, I _O = -10mA	16	16.5	—	V
	V _{OH2}	V _{CC} = 18V, I _O = -100mA	15.5	16	—	V
Overheat protection operating temperature	T _{TS}		120	140	160	°C

■ 6932852 0012773 008 ■

Panasonic

■ Pin Descriptions

Pin No.		Symbol	Description
DIL	SO		
1	1	V_C	Pin to apply the supply voltage to the output transistor
2	2	V_{OUT}	IC output pin. Drives the MOS-FET or bipolar transistor.
3	3	$V_{OUT.COM}$	Output transistor ground pin
4	4	V_F	Detects the mean level of output pulses and provides output duty control and timer control.
5	7	ON/OFF	Pin to turn on/off the IC. The IC stops at "H" (output = "L") and starts at "L".
6	8	OVP	Detects an over-voltage and stops the IC; the stop state is held.
7	9	V_{IN}	Pin to feed back the output voltage of the power supply. It has internal gain.
8	10	I_{IN}	Pin to feed back the output voltage of the power supply.
9	11	T_{ON}	Pin to connect the resistor which determines the tilting of the charge period of an internally oscillated triangular wave.
10	12	C_F	Pin to connect the capacitance which determines the frequency of an internally oscillated triangular wave.
11	13	T_{OFF}	Pin to connect the resistor which determines the tilting of the discharge period of an internally oscillated triangular wave.
12	14	C_T	Pin to connect the capacitance which determines a timer control frequency.
13	17	GND	Ground pin for the system.
14	18	CLM ⁻	Overcurrent detection pin on the negative potential side.
15	19	CLM ⁺	Overcurrent detection pin on the positive potential side.
16	20	V_{CC}	Pin to apply the supply voltage. Detects the start and stop voltage.
—	5	FIN(GND)	Pin directly connected to the IC chip. Joint use for discharge and GND.
—	6	FIN(GND)	Pin directly connected to the IC chip. Joint use for discharge and GND.
—	15	FIN(GND)	Pin directly connected to the IC chip. Joint use for discharge and GND.
—	16	FIN(GND)	Pin directly connected to the IC chip. Joint use for discharge and GND.

■ Application Circuit

1) AN8090 flyback application

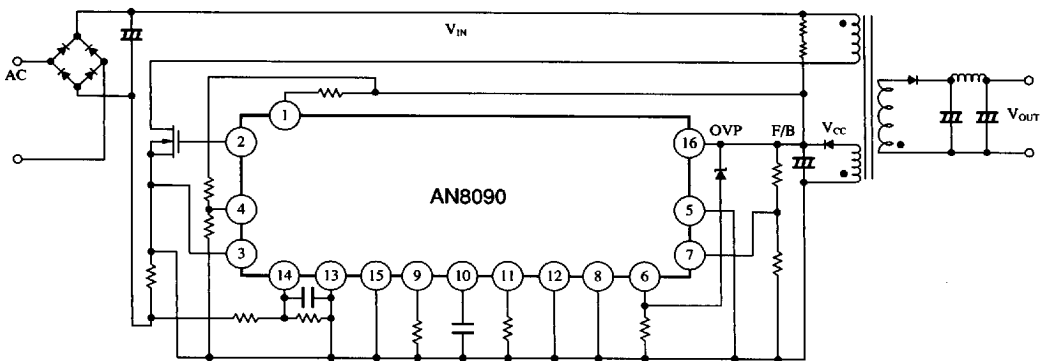

Voltage
Regu-
lators

■ 6932852 0012774 T44 ■

Panasonic

■ Application Circuit (cont.)

2) AN8090 feed-forward application

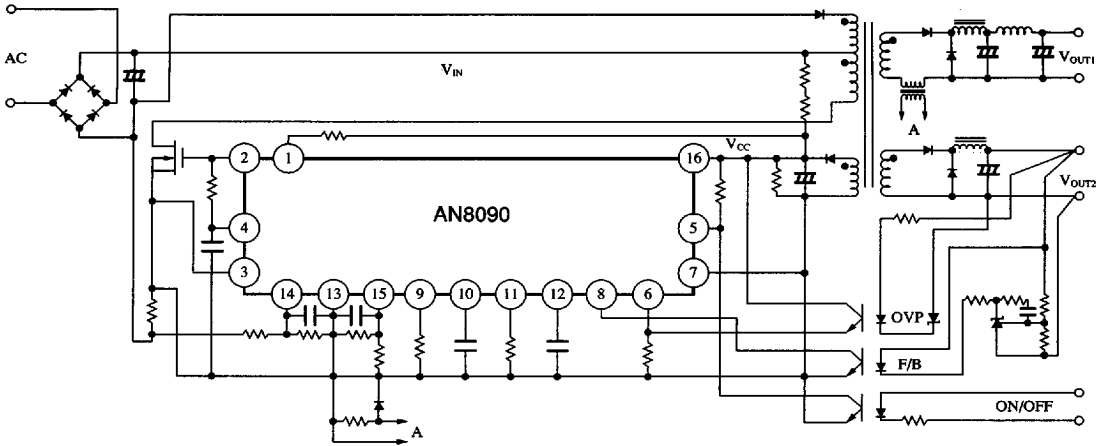

■ Supplementary Descriptions

● Characteristic Charts

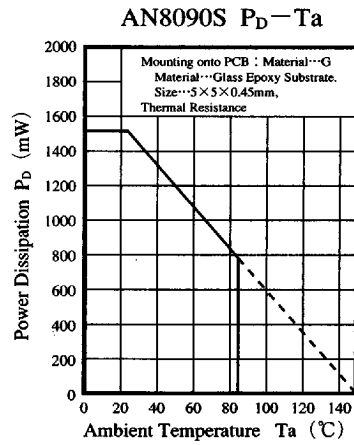
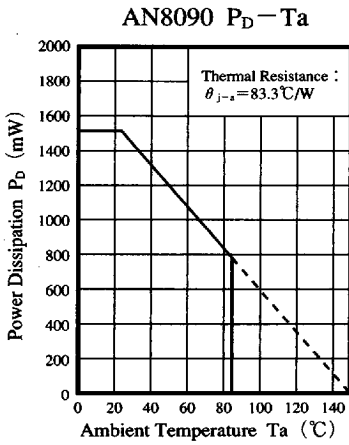

■ 6932852 0012775 980 ■

Panasonic

■ Supplementary Descriptions (cont.)

● Timing Charts

In Case of Normal Operation

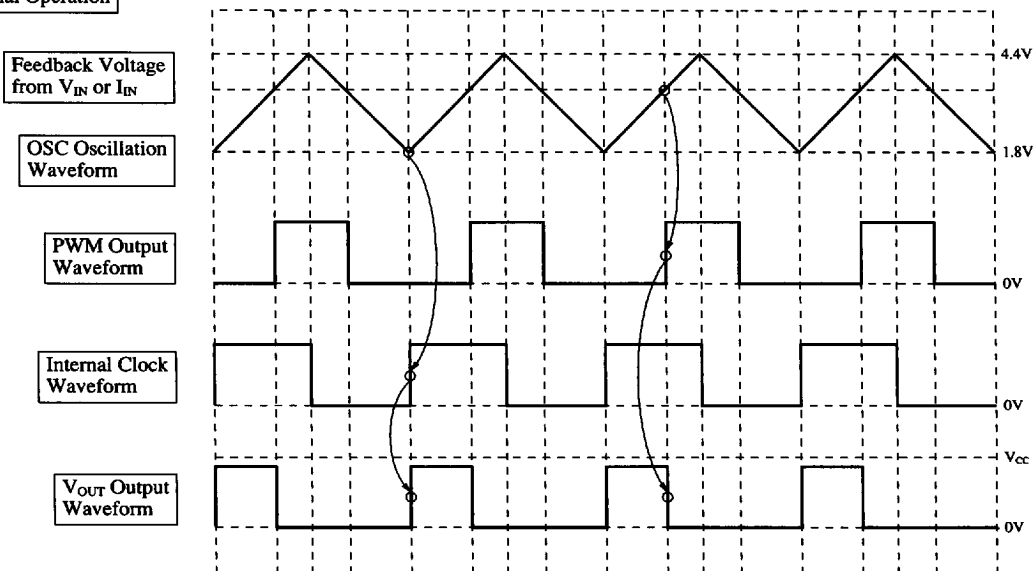

In Case of Current Limiting Operation (Note 1)

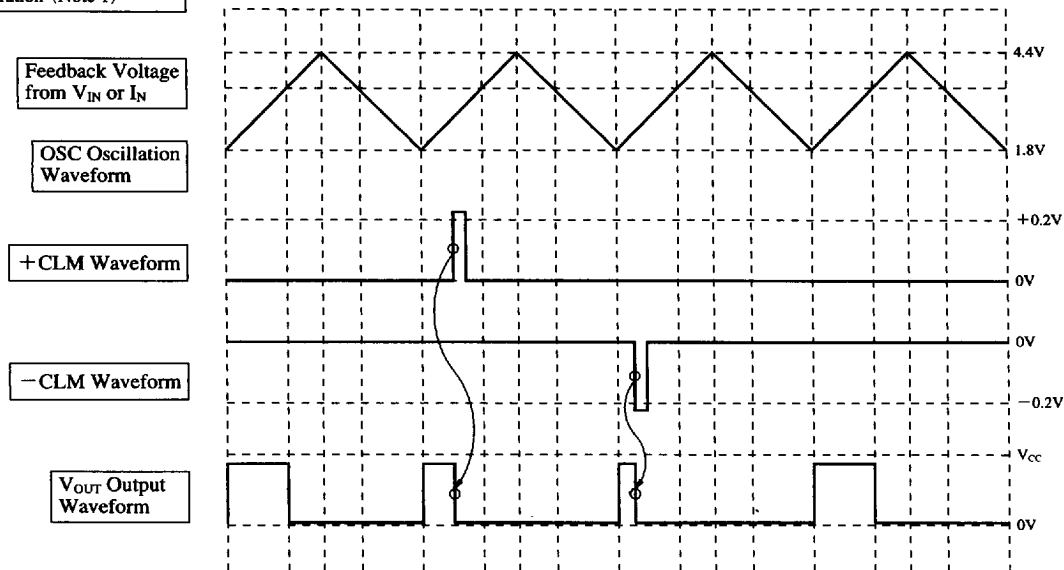

Note 1) The V_F pin voltage should be higher than the $T_{OFF(max)}$ control start voltage ($\leq 4V$).

■ 6932852 0012776 817 ■

Panasonic

■ Supplementary Descriptions (cont.)

● Timing Charts (cont.)

In Case of $T_{OFF(max)}$ Control Operation Note 2)

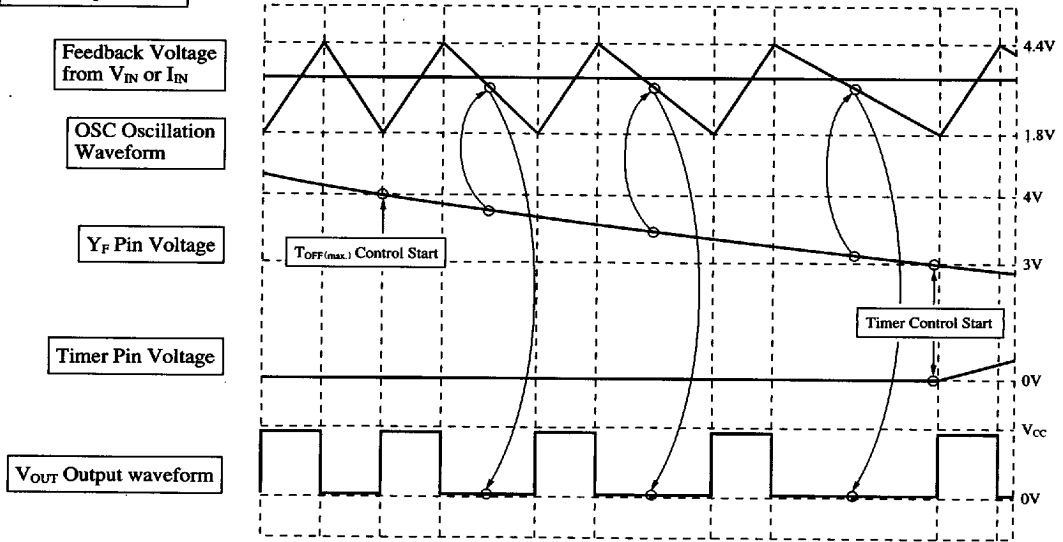

In Case of Timer Control Operation Note 3)

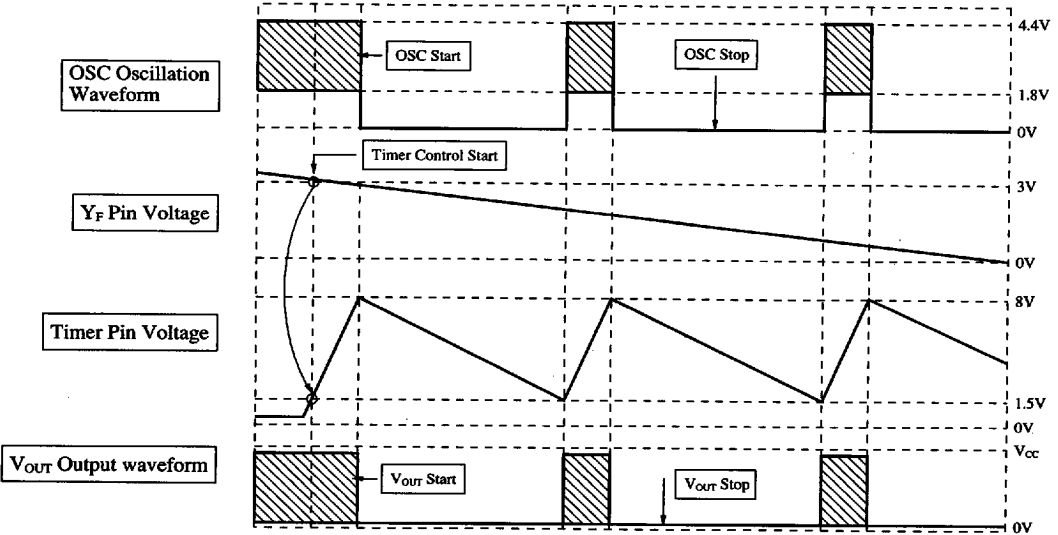

Note 2) In case of current limiting operation ($CLM+ \geq 0.2V$ and $CLM- \leq -0.2V$), $T_{OFF(max)}$ control and timer control work.
 Note 3) Even during timer control operation, the OFF period of OSC (V_{OUT}) is controlled by $T_{OFF(max)}$ control.

■ 6932852 0012777 753 ■

Panasonic

This datasheet has been download from:

www.datasheetcatalog.com

Datasheets for electronics components.