

Original date... 21 October 2000

Last revision 24 January 2001

## MEASUREMENTS

The following measurements are described on this page:

1. Secondary Coil inductance
2. Self resonant frequency of Secondary Coil
3. Resonant frequency of Secondary Coil with Terminal attached
4. Resonant frequency of Primary Circuit
5. Frequencies for determining the coefficient of coupling

Note:( the coils undergoing the following measurements should be a metre or more away from obstructions)

### 1. MEASURING SECONDARY COIL INDUCTANCE

The 0.1uF capacitor and the coil form a series LC circuit. Vary the signal generator frequency until a maximum signal is observed on the oscilloscope and note the frequency. Calculate L using the formula given above with the measured frequency and the 0.1uF capacitance. The resonant frequency of the above circuit measured at 2250Hz.

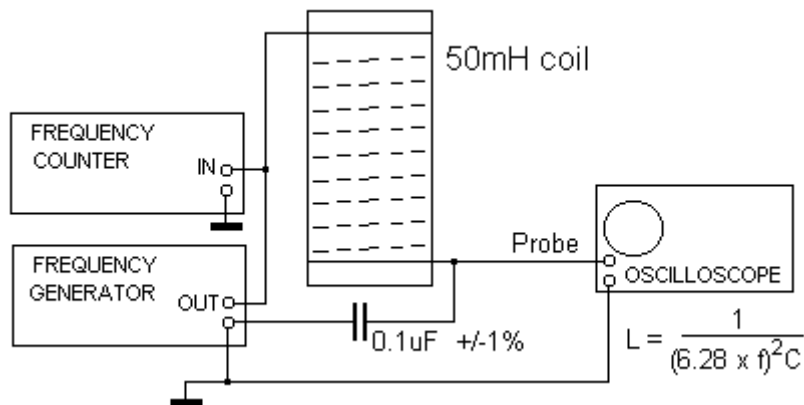

### 2. MEASURING SELF RESONANCE

If the secondary coil is mounted with the primary coil, the primary coil must not be connected to its capacitor to form a primary resonant circuit. The open spark gap will suffice for this condition.

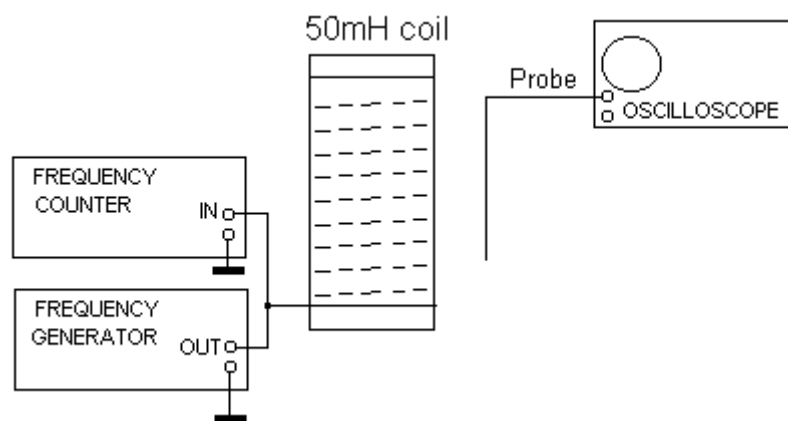

Vary the Signal Generator frequency until the signal observed on the oscilloscope is at a maximum.

The coil described in the Secondary Coil Construction page was used in this measurement. It was self resonant at 155kHz. Calculate the coil self capacitance using the measured frequency and the calculated Coil inductance (50mH) and the formula at the right. The self resonant frequency of the 50mH coil measured at 155kHz. The calculated self capacitance worked out to 21pF

$$C = \frac{1}{(2\pi f)^2 L}$$

### 3. MEASURING SECONDARY CIRCUIT RESONANT WITH A TERMINAL

The same set-up was used to measure Secondary Circuit resonant frequencies with different Terminals. A flexible 110mm diameter aluminium pipe forming a toroid provided a resonant frequency of 117kHz. Tuning was achieved by stretching and compressing the flexible pipe. Using the formula for C above with the measured frequency and 50mH total Secondary Circuit capacitance calculated to be 37pF. Subtracting from this value the self capacitance (21pF) gives a Terminal capacitance of 16pF.

This is a special case of one particular coil which matched a particular primary circuit frequency. The same technique can be used for many different size coils and frequencies.

#### 4. MEASURING PRIMARY CIRCUIT RESONANT FREQUENCY

The Primary circuit must be isolated from the secondary circuit for this measurement. Simply remove the secondary coil. Connect a short jumper wire across the spark gap to place the primary coil in parallel with the primary capacitor. The following diagram shows the set-up for this measurement:

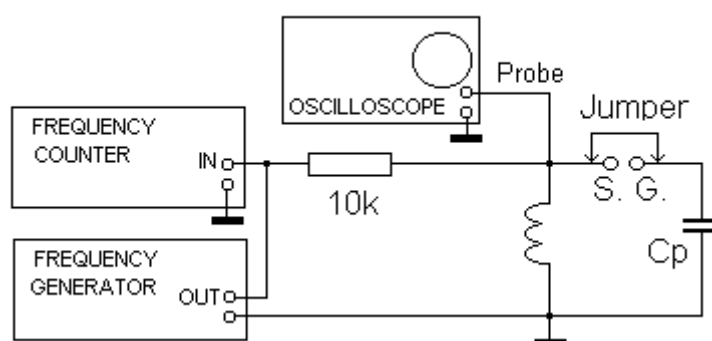

Adjust Signal Generator for maximum amplitude on the Oscilloscope and read the Primary Circuit resonant Frequency on the Counter. Q of the circuit can be determined by measuring the frequencies which give an output of 0.7 x maximum level obtained at resonance on the oscilloscope. (-3dB points) Dividing the difference between these two frequencies into the resonant frequency yields the Q. The actual Q will be slightly higher because of the 10k resistor in the measuring circuit. A Q of about 50 should be expected.

#### 5. FREQUENCY MEASUREMENTS FOR DETERMINING COUPLING COEFFICIENT(k)

The following arrangement is set up to locate the two frequencies associated with a tuned RF transformers. The primary and secondary coils are in their normal configuration concentric to one another, but the spark gap is jumpered across. . For these measurements to be valid, the primary and secondary circuits must be independently resonant to the same frequency as measured in 3. and 4. above. (The Oscilloscope probe is attached to a metre of wire and dangled about 1 metre from the secondary coil. )

Locate two frequencies which give a peak signal on the oscilloscope. One of these frequencies will be above the original resonant frequency and the other will be below it. These three frequencies can be used to calculate the coefficient of coupling (k) using the following formulas:

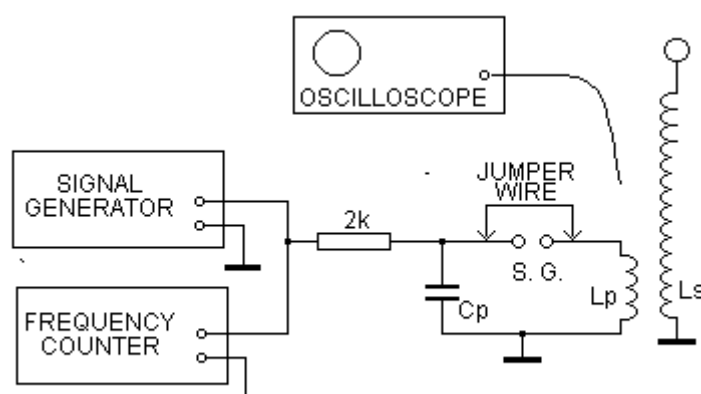

COEFFICIENT OF COUPLING MEASUREMENT SET-UP  
If the values of k are significantly different (about

$$f(\text{lower}) = \frac{f_r}{\sqrt{1-k}} \quad \text{and} \quad f(\text{upper}) = \frac{f_r}{\sqrt{1-k}}$$

$$k = \left[ \frac{f_r}{f(\text{lower})} \right]^2 - 1 \quad \text{and} \quad k = 1 - \left[ \frac{f_r}{f(\text{upper})} \right]^2$$

10% or more) using the two lower expressions, either the primary or secondary circuits were not tuned to the same frequency  $f_r$ , or there was an error in measurements.

Source: RADIO ENGINEERING HANDBOOK HENNEY 3rd Edition 1941 page 149

## 6. RING UP AND RING DOWN MEASUREMENTS

The ring up and ring down measurements involve:

1. replacing the high voltage transformer (Neon sign transformer secondary winding) with a 680 ohm charging resistor and a 12 Volt dc power supply
2. Substituting the spark gap with the contacts of a vibrating reed relay
3. Observing waveforms in the Primary and Secondary circuits with a dual trace oscilloscope

The circuit I used is shown below:

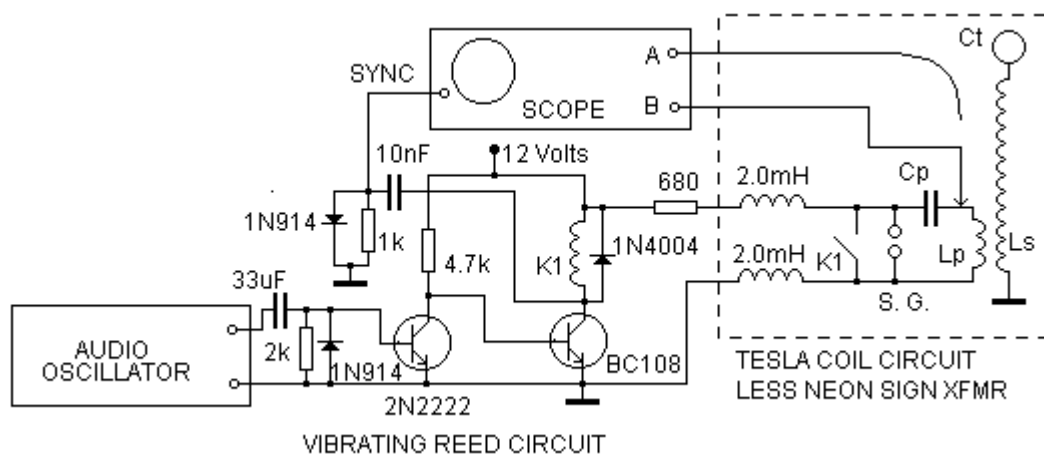

The audio oscillator was set to 250Hz which resulted in K1, a reed type relay to vibrate at the same rate. With K1 contacts open, the Primary Circuit capacitor charged up through a 680 ohm resistor to 12 Volts dc. When the contacts closed, this capacitor dumped its charge into the Primary Circuit coil and commenced to oscillate. At the same time a negative sync pulse triggered the Oscilloscope. The Primary and Secondary Circuit oscillations were fed to A and B oscilloscope inputs. In this circuit the trigger occurred about 50 milliseconds ahead of K1 contact closure. The built in oscilloscope trigger delay allowed for wave form centering and easy observation. The following is a set of sketches of my observations:

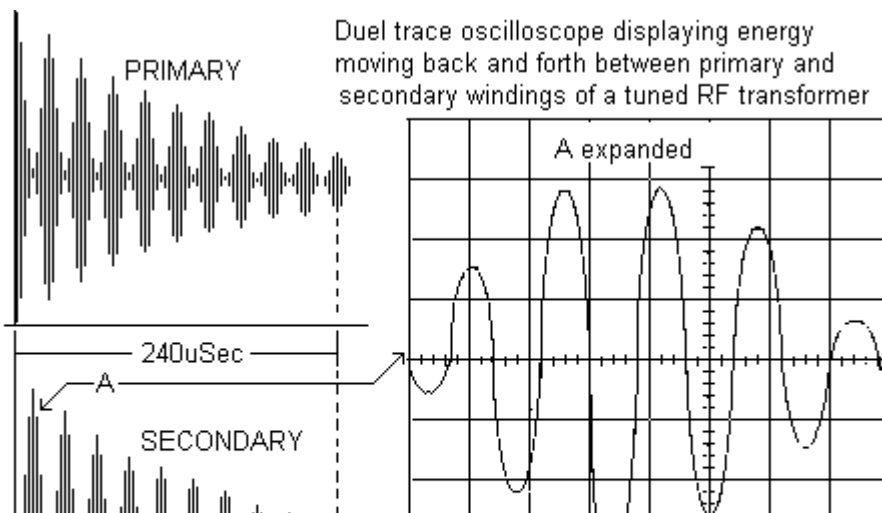

Please note that the circuit above not an optimized design. It was based on what I had in my junk box (static assets) at the time. I did experience relay contact bounce, but I was still able to see energy moving back and forth between the Tesla Coil Primary and Secondary circuits. A more sophisticated solid state

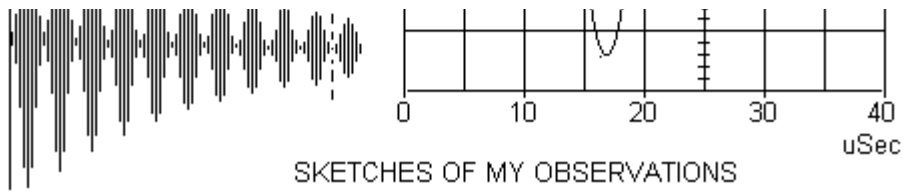

design using MOSFETs with milli-ohm source to drain resistances when switched on would be much better. The effects of spark gap quenching could

be simulated using appropriate MOSFET input waveforms.

 [return to homepage](#)