

# TAOS 2.0

## MV Build - Final

05/09/2006

DATE	CHANGE NO.	REV

DRAWER	EE	DATE	POWER	DATE	<b>INVENTEC</b>
DESIGN					
CHECK					
RESPONSIBLE					
TITLE					TAOS20
SIZE =	3	VER :			
FILE NAME :	XXXX-XXXXXX-XX				
P/N	XXXXXXXXXXXX				
				SIZE	A3
				CODE	CS
				DOC. NUMBER	1310A20305
				REV	A02
				SHEET	1 OF 69

## Table Of Content

PAGE	PAGE	PAGE
5- DC& Battery Charger	29- Blank	53- USB CONN (USB_1394 DB)
6- Selector & Battery CONN	30- Blank	54- CardBus Controller
7- +V5A, +V3A & +V1.8S	31- Blank	55- PC Card Slot
8- OCP	32- Blank	56- 6 IN 1 Card CONN
9- +VCC_NB & V1.2S	33- Blank	57- 1394 CONN (USB_1394 DB)
10- +VCC_CORE	34- Blank	58- MiniCard (WLAN)
11- DDR2 & V2.5 & +V1.5S	35- CRT& S-Vedio CONN	59- LAN Interface
12- Power(Sleep)	36- LCD CONN	60- LAN RJ45 CONN
13- Power(Sequence)	37- SB450-1	61- Docking CONN
14- Blank	38- SB450-2	62- Screw
15- Clock Generator	39- SB450-3	63- MDC CONN
16- AMD CPU-1	40- SB450-4	64- Finger Print DB
17- AMD CPU-2	41- SB450-5	65- BlueTooth
18- AMD CPU-3	42- KBC	66- Power/LID Switch & LED
19- AMD CPU-4	43- FWH (1M) & Accelero-Meter (NI)	67- Blank
20- Thermal & Fan Controller	44- INT. KBC/Touch Pad Devices	68- LED/Switch Botton DB
21- RS485MH / RS480M -1	45- Super I/O	
22- RS485MH / RS480M -2	46- Blank	
23- RS485MH / RS480M -3	47- TPM V1.2	
24- RS485MH / RS480M -4	48- AZALIA CODEC	
25- RS485MH / RS480M -5	49- Earphone & MIC JACK	
26- DDR2-DIMM0	50- Audio AMP & INT. Speaker CONN	
27- DDR2-DIMM1	51- HDD CONN (SATA)	
28- DDR2-DAMPING	52- Fixed ODD CONN (PATA)	

**INVENTEC**

TITLE TAOS20

SIZE A3	CODE CS	DOC. NUMBER 1310A20305	REV A02
------------	------------	---------------------------	------------

CHANGE by *Drawer Name* 20-Apr-2006

SHEET 2 OF 69

# Inventec Confidential

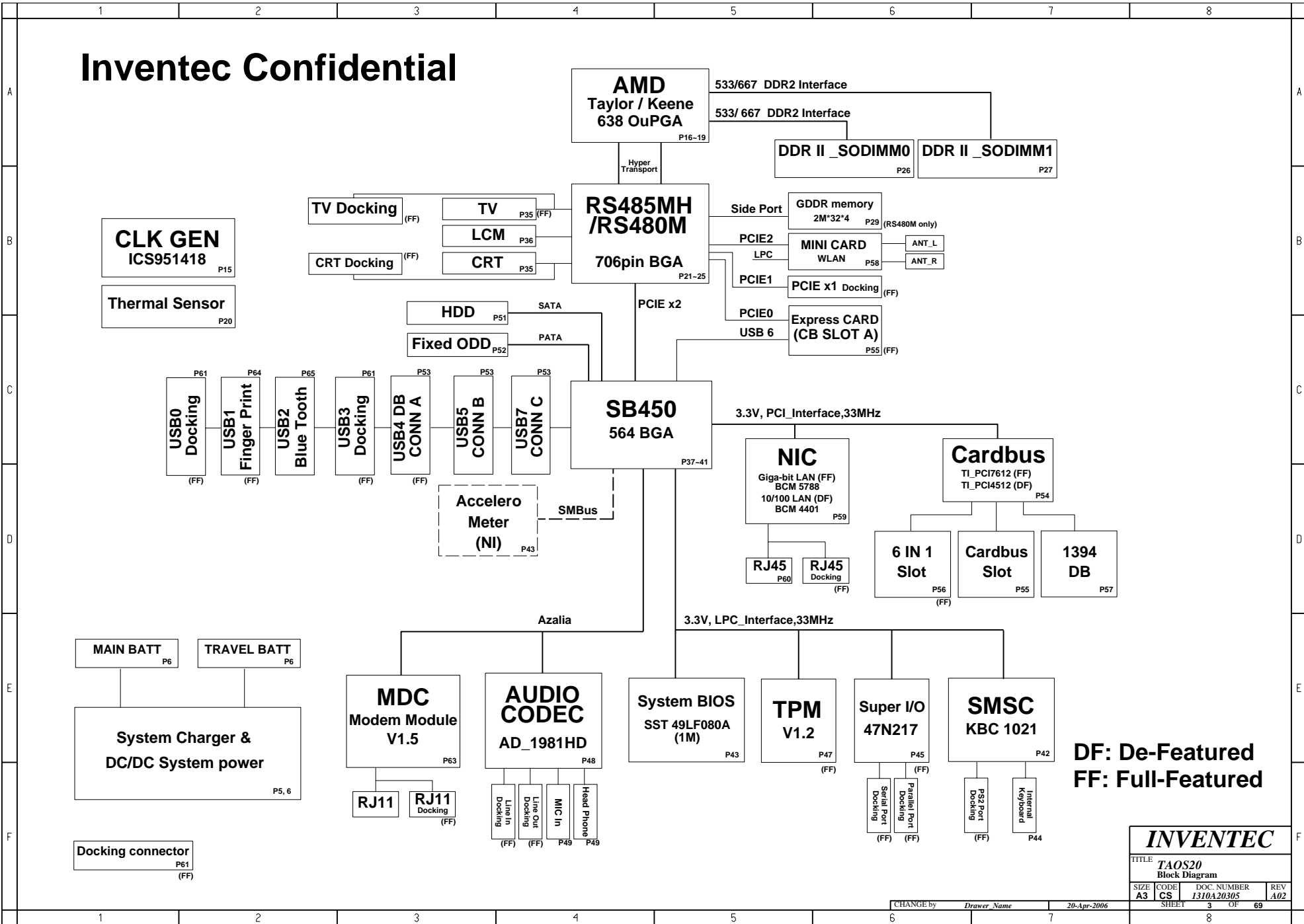

DF: De-Featured  
FF: Full-Featured

<b>INVENTEC</b>			
TITLE TAOS20 Block Diagram			
SIZE A3	CODE CS	DOC. NUMBER 1310A20305	REV A02
CHANGE by Drawer Name		20-Apr-2006	SHEET 3 OF 69

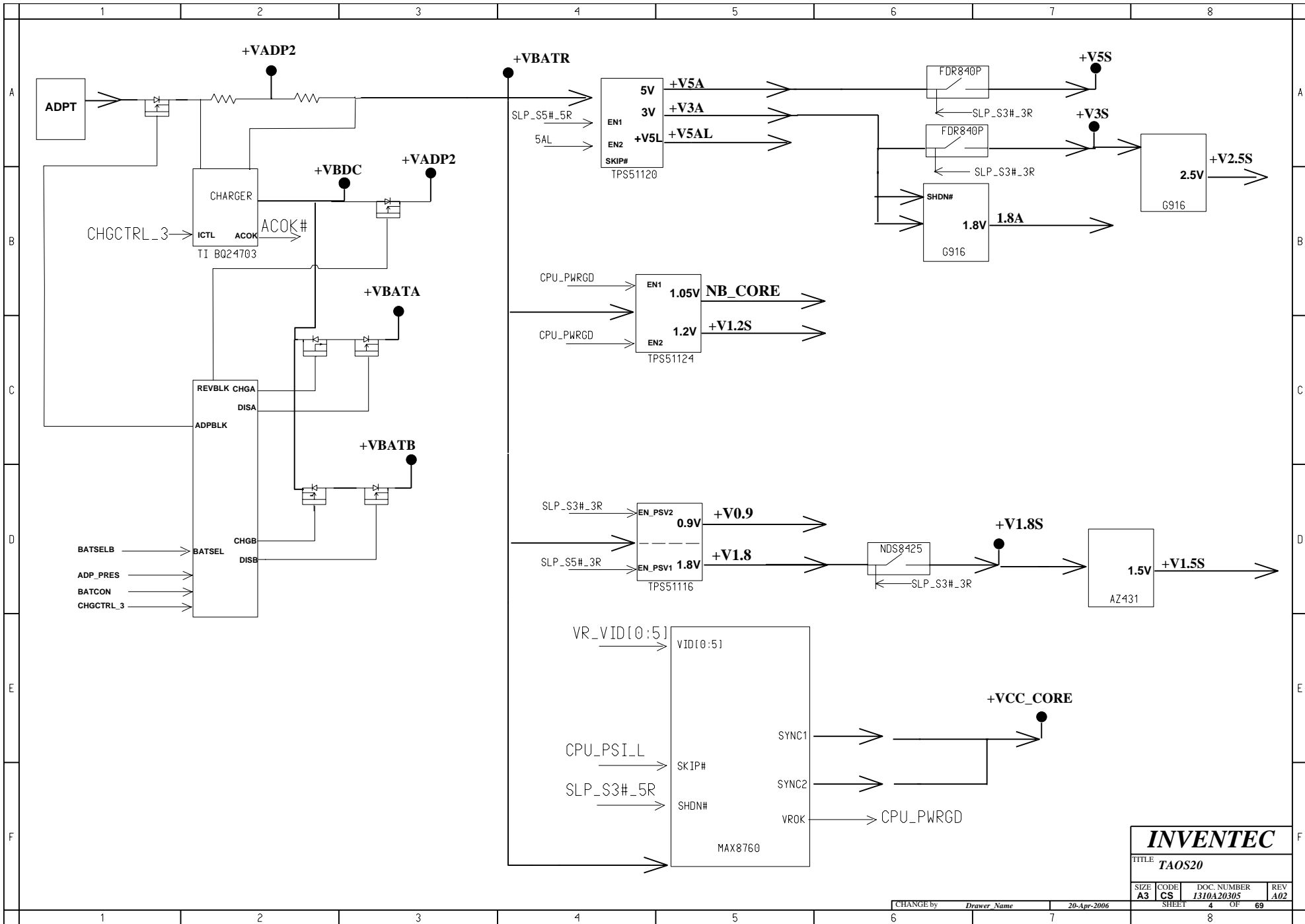

<b>INVENTEC</b>			
TITLE TAOS20			
SIZE A3	CODE CS	DOC. NUMBER 1310A20305	REV A02
CHANGE by Drawer Name		20-Apr-2006	
SHEET 4		OF 69	

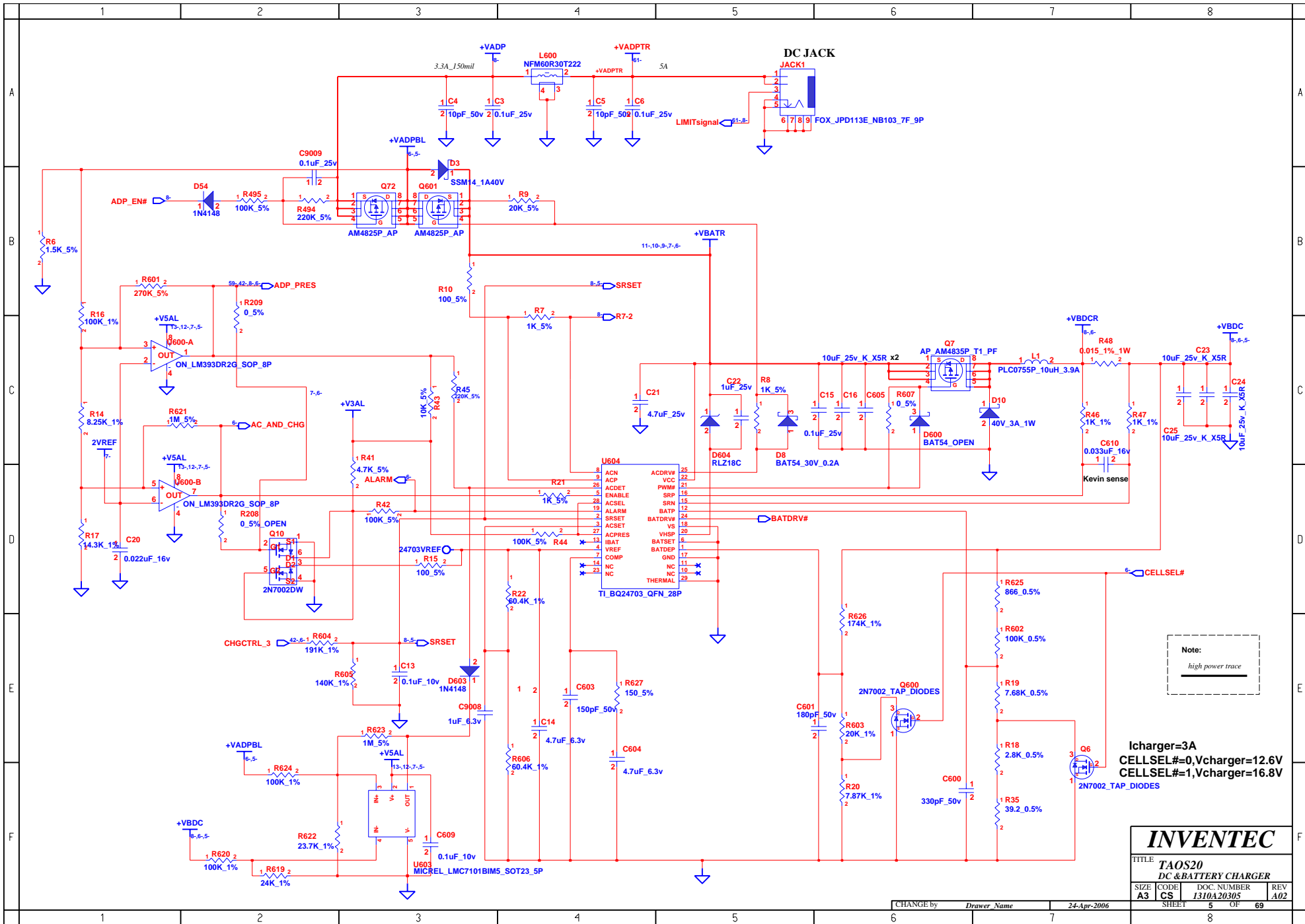

Note:  
high power trace

Icharger=3A  
CELLSEL#=0,Vcharger=12.6V  
CELLSEL#=1,Vcharger=16.8V

<b>INVENTEC</b>			
TITLE <b>TAOS20 DC &amp; BATTERY CHARGER</b>			
SIZE A3	CODE CS	DOC NUMBER I310A20305	REV A02
CHANGE by Drawer Name		24-Apr-2006	
SHEET 5		OF 69	

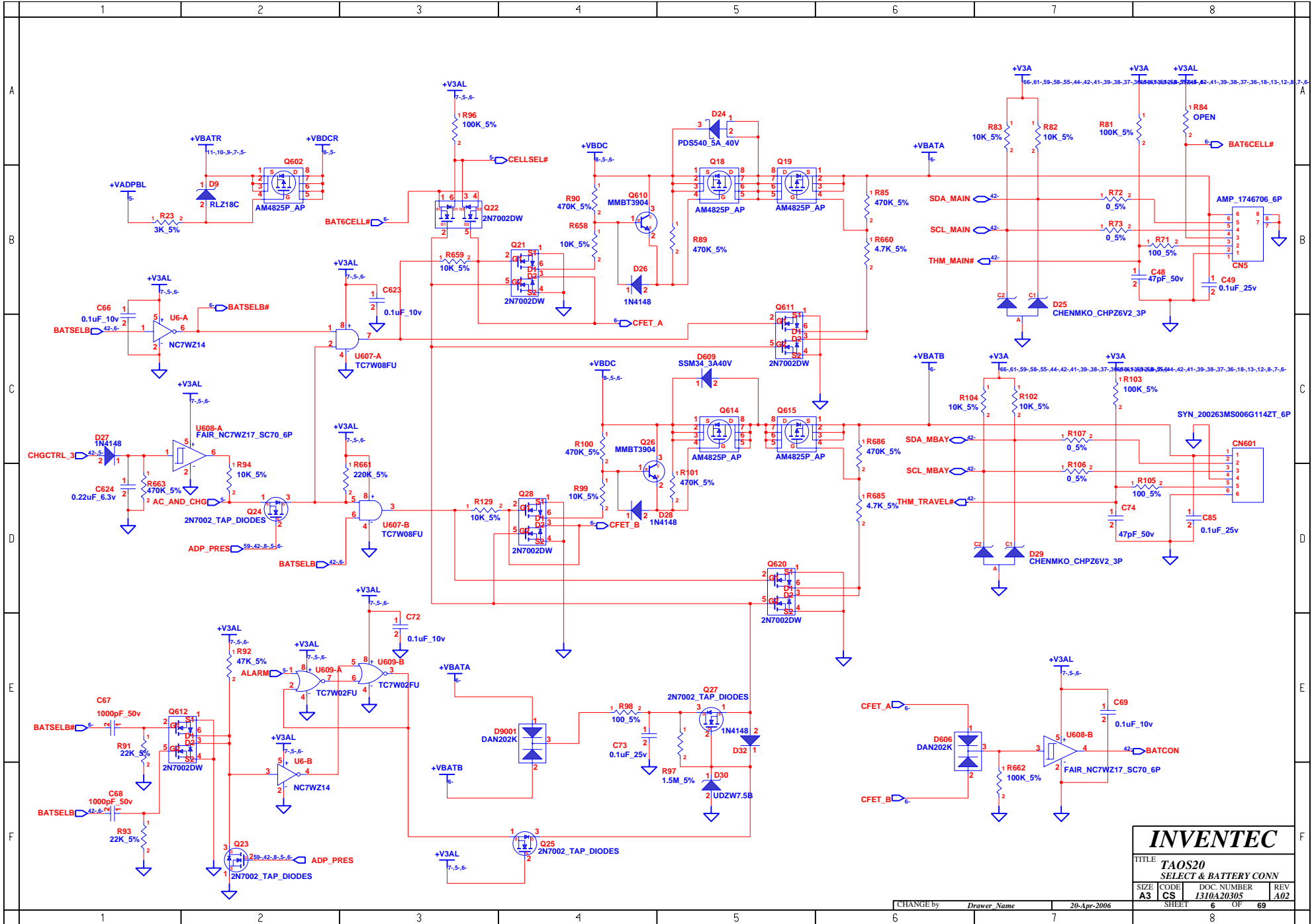

# INVENTEC

TITLE			
TAOS20 SELECT & BATTERY CONN			
SIZE	CODE	DOC. NUMBER	REV
A3	CS	I310A20305	A02

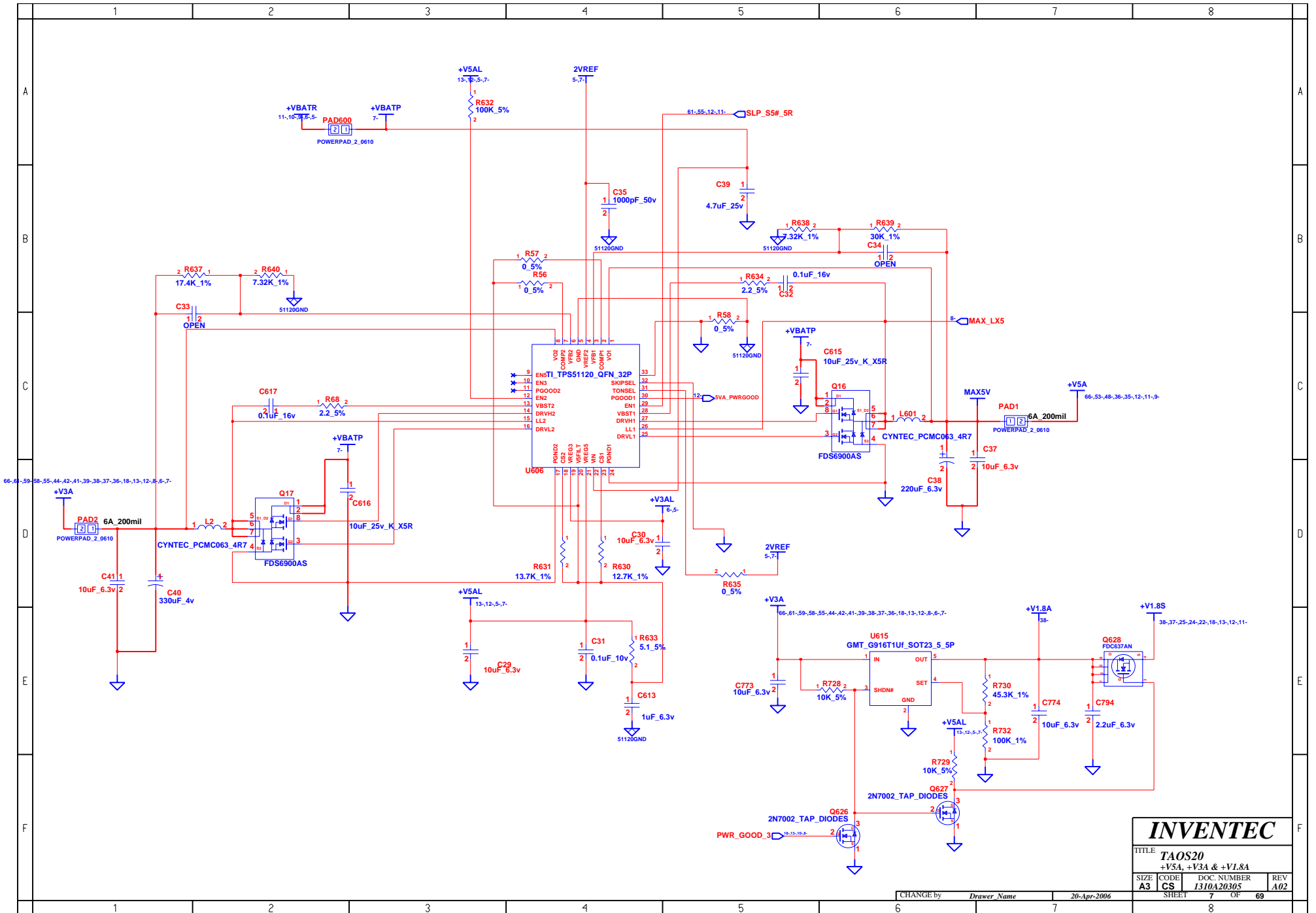

<b>INVENTEC</b>			
TITLE TAOS20			
+V5A, +V3A & +V1.8A			
SIZE A3	CODE CS	DOC. NUMBER 1310A20305	REV A02
CHANGE by <i>Drawer Name</i>		20-Apr-2006	SHEET 7 OF 69

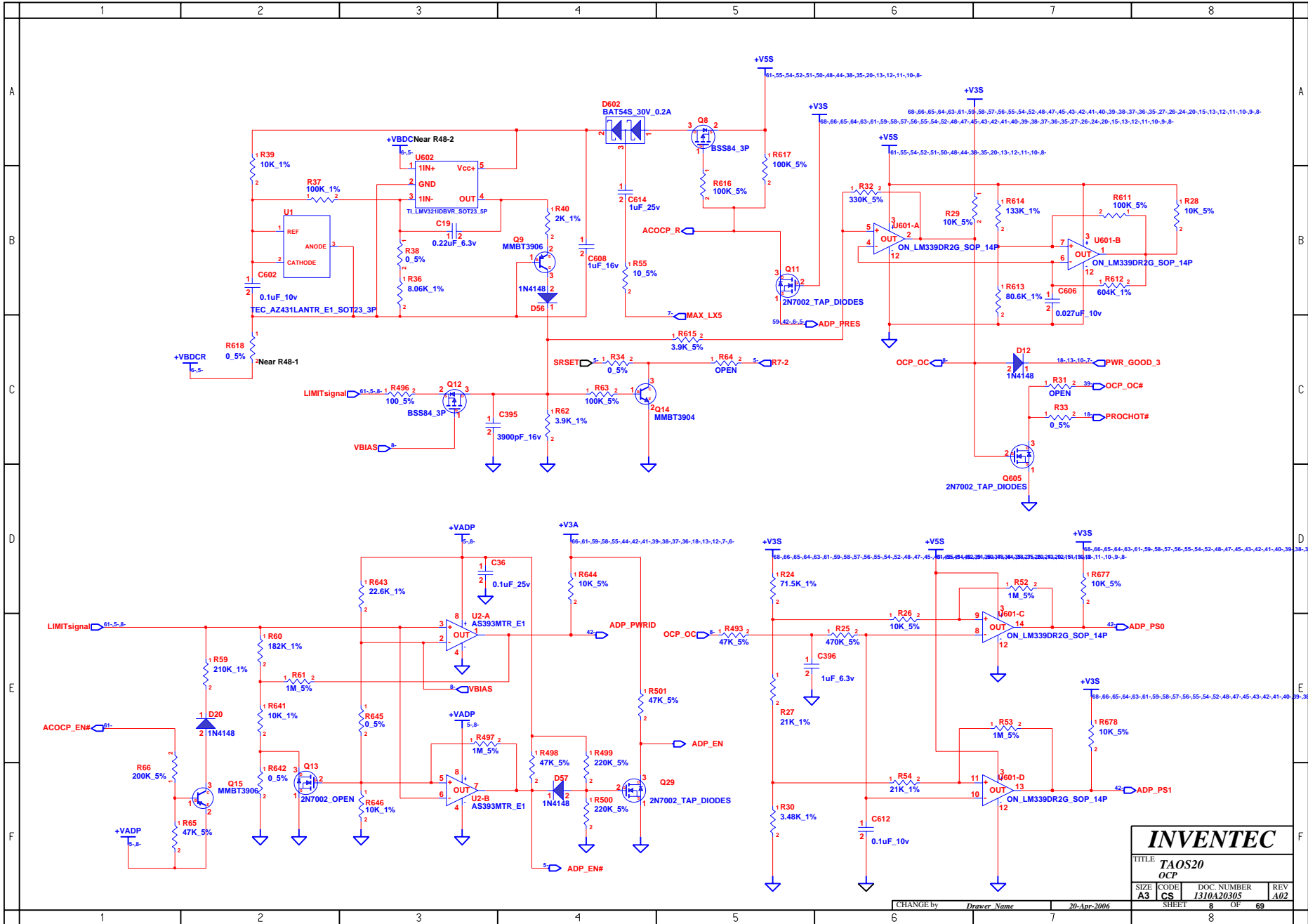

**INVENTEC**

TITLE			
TAOS20			
OCP			
SIZE	CODE	DOC. NUMBER	REV
A3	CS	I310A20305	A02

CHANGE by *Drawer Name* 20-Apr-2006

SHEET 8 OF 69



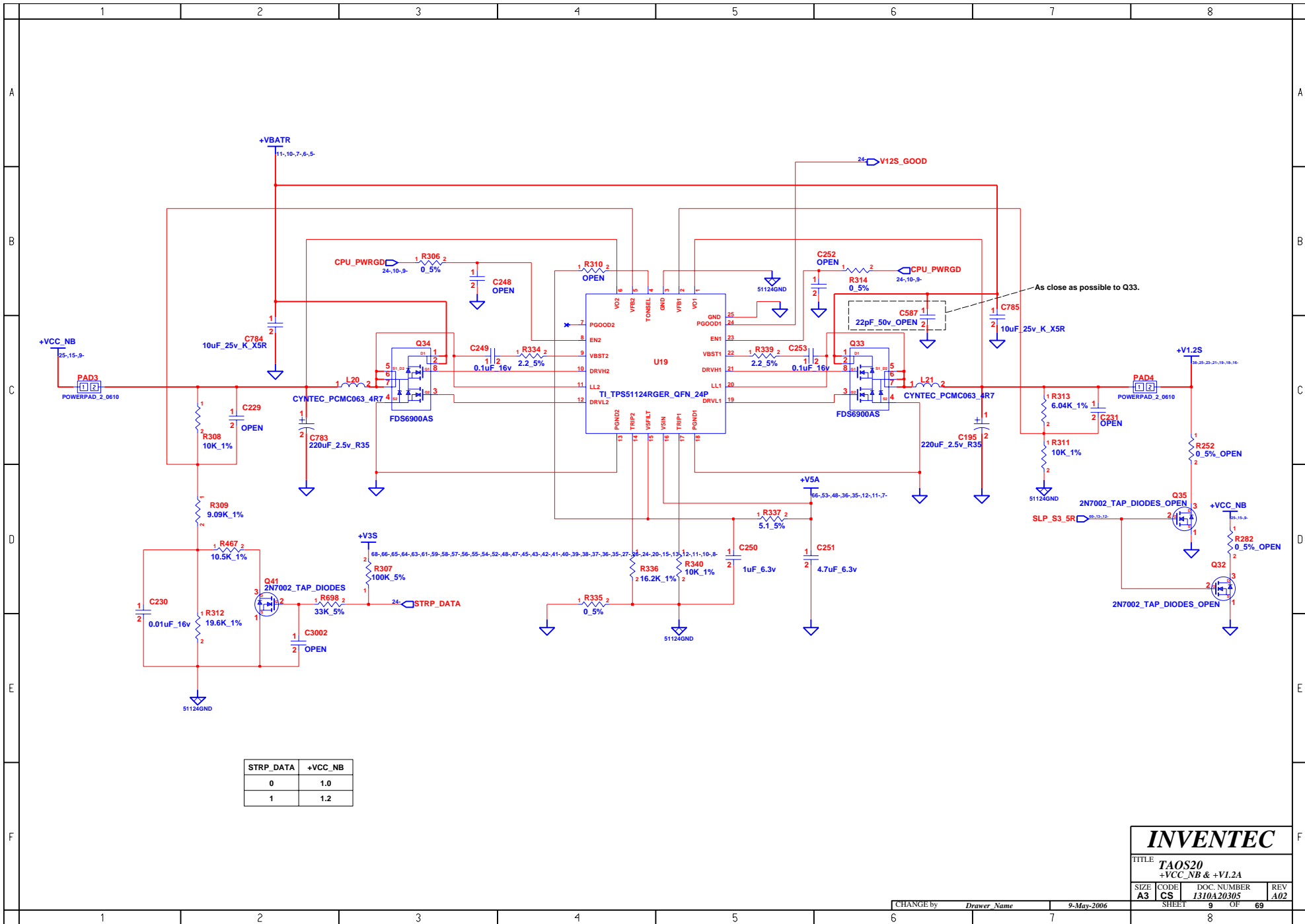

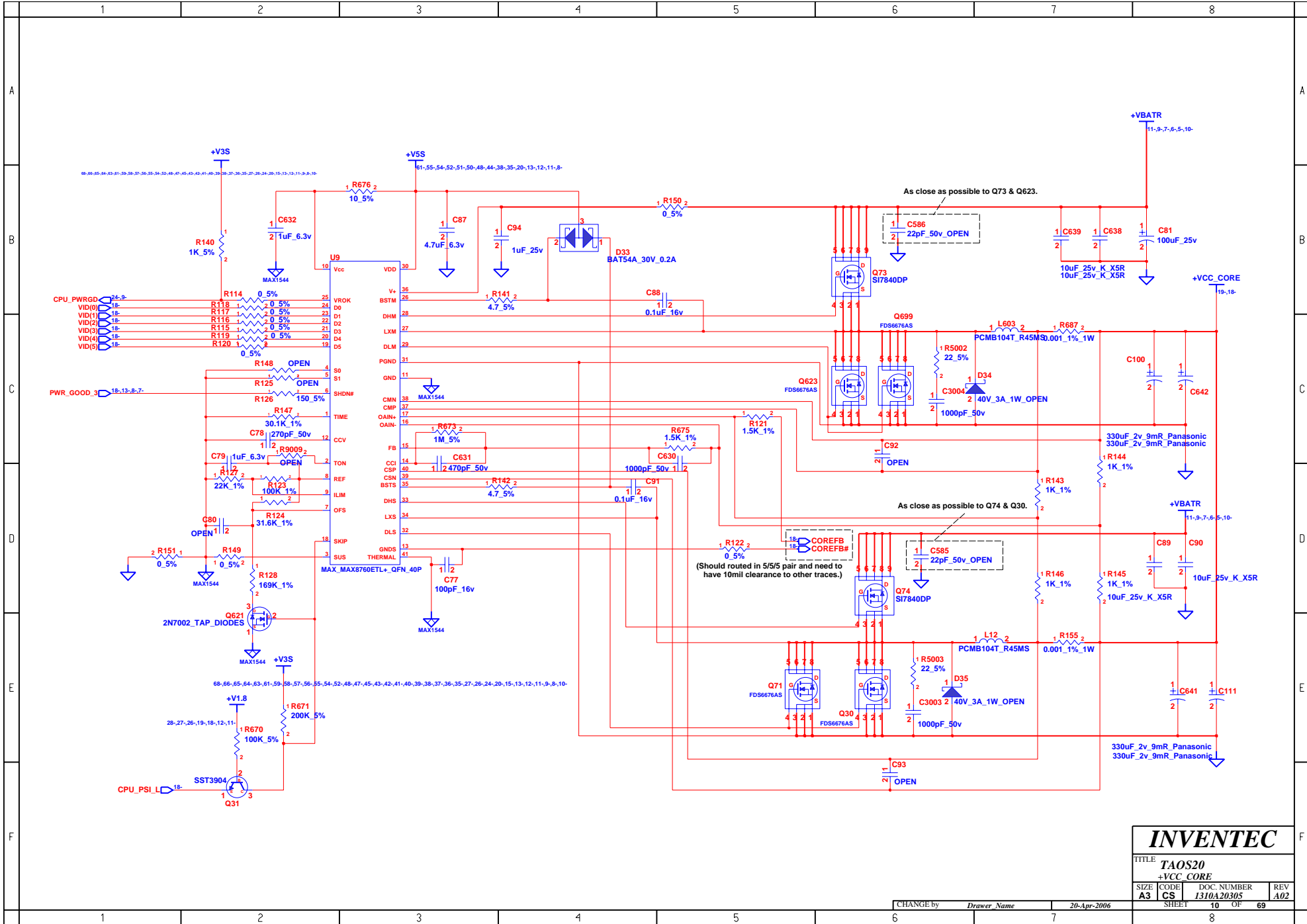

# INVENTEC

TITLE  
**TAOS20**  
**+VCC CORE**

SIZE	CODE	DOC. NUMBER	REV
A3	CS	I310A20305	A02

CHANGE by	Drawer Name	20-Apr-2006
-----------	-------------	-------------

SHEET	10	OF	69
-------	----	----	----

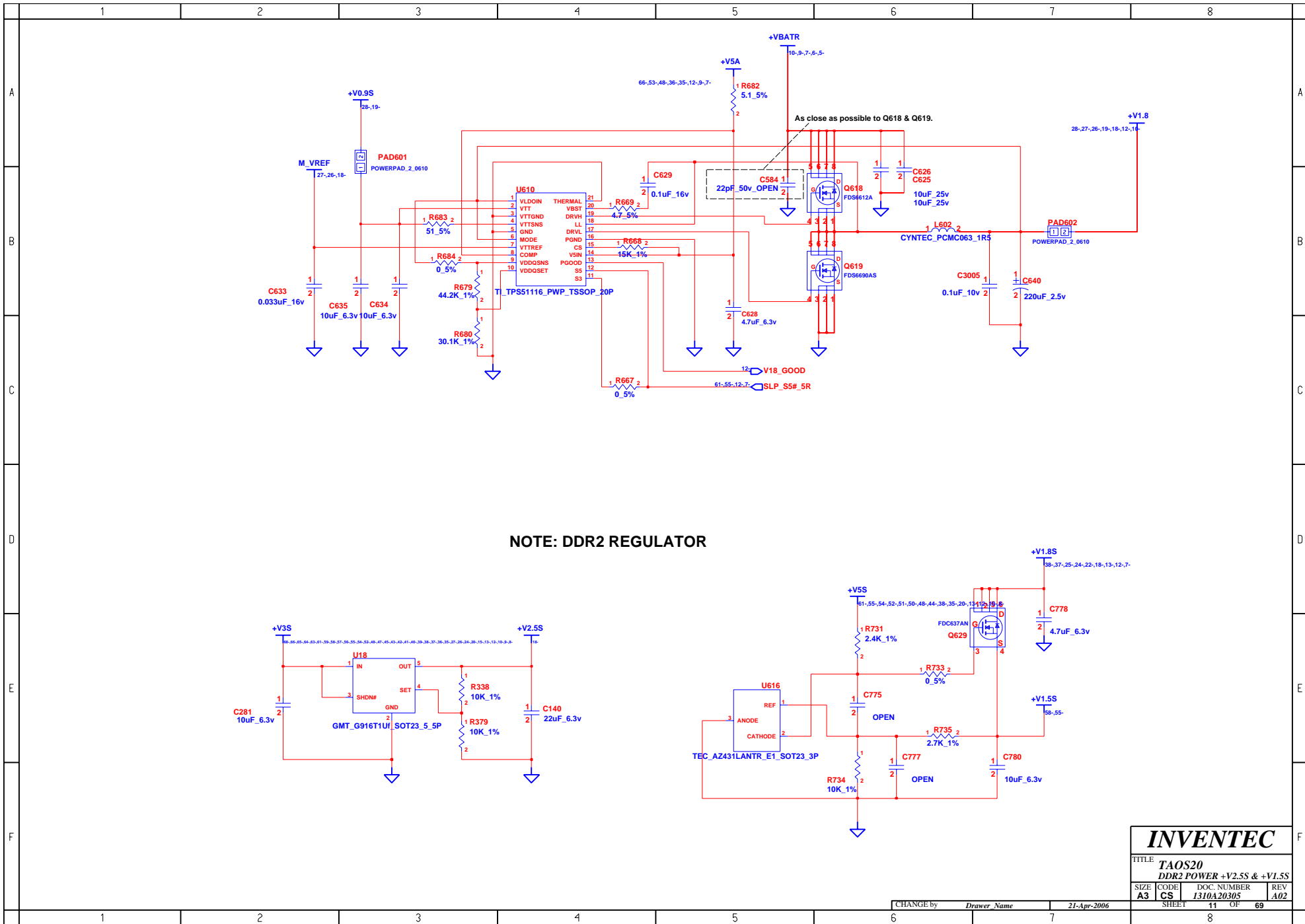

<b>INVENTEC</b>			
TITLE <b>TAOS20</b>			
DDR2 POWER +V2.5S & +V1.5S			
SIZE <b>A3</b>	CODE <b>CS</b>	DOC. NUMBER <b>I310A20305</b>	REV <b>A02</b>
CHANGE by <i>Drawer Name</i>		21-Apr-2006	
SHEET 11		OF 69	

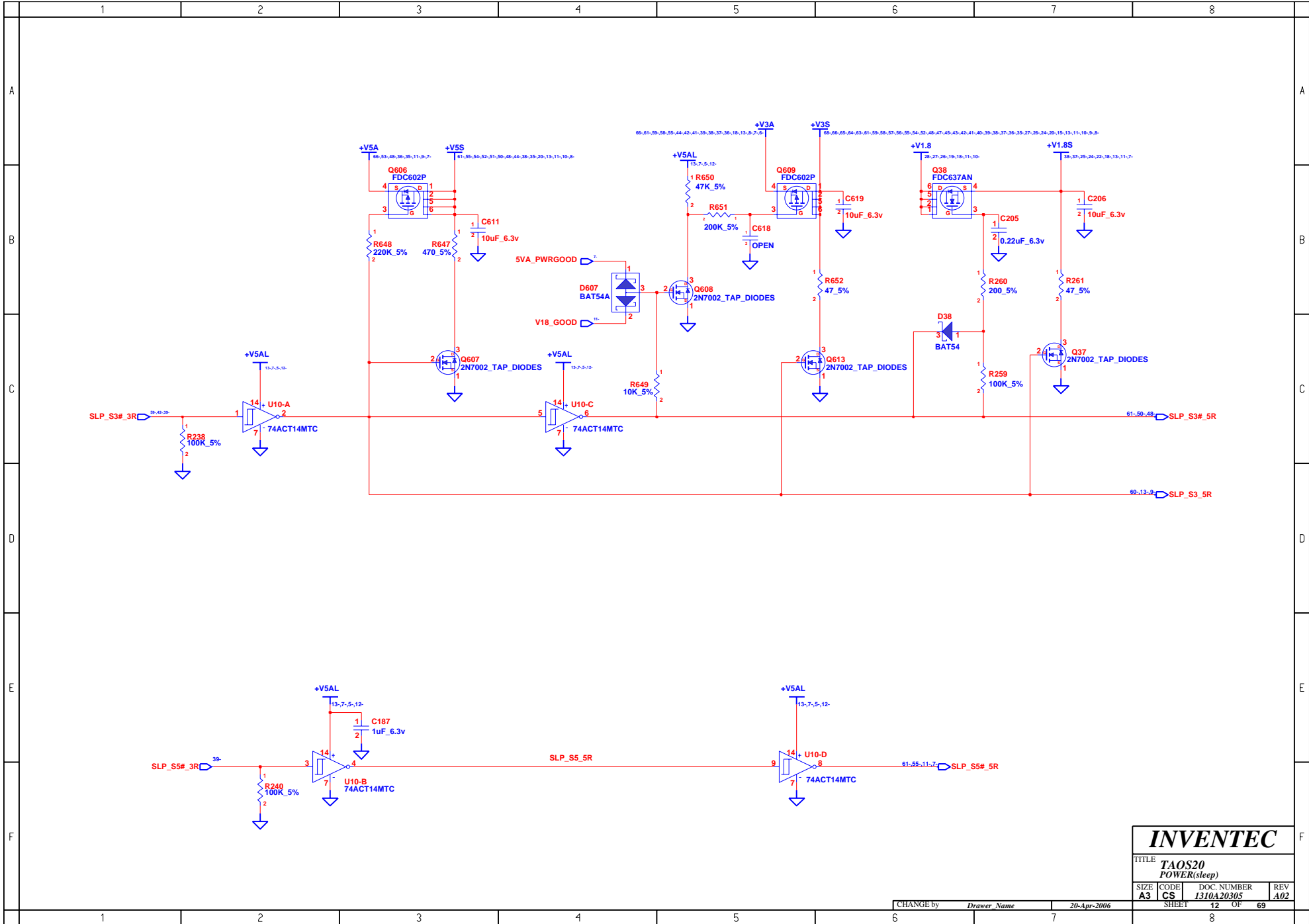

**INVENTEC**

TITLE			
TAOS20			
POWER(sleep)			
SIZE	CODE	DOC. NUMBER	REV
A3	CS	I310A20305	A02

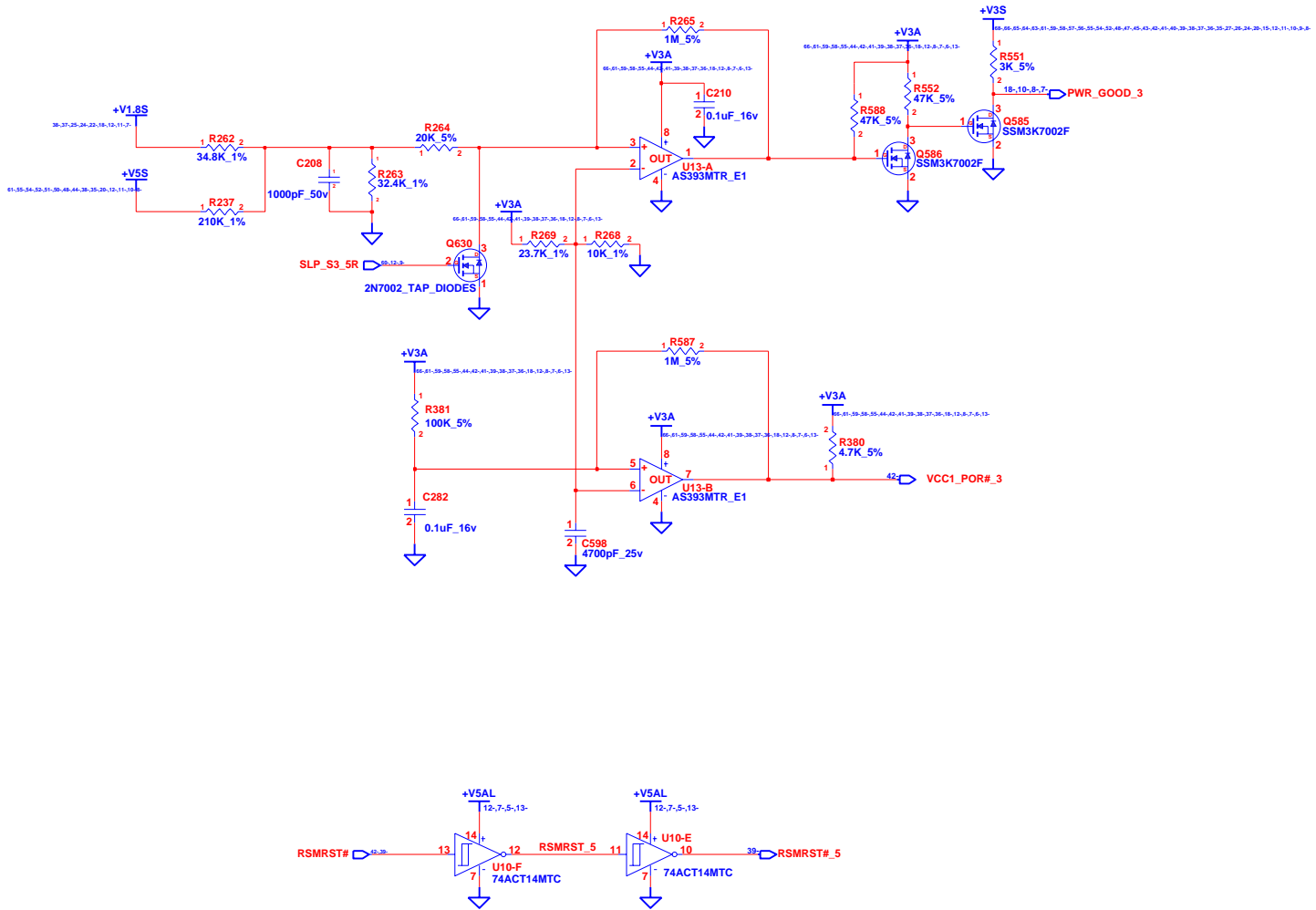

# INVENTEC

TITLE  
**TAOS20**  
**POWER(Sequence)**

SIZE	CODE	DOC. NUMBER	REV
A3	CS	I310A20305	A02

CHANGE by *Drawer Name* 20-Apr-2006 SHEET 13 OF 69

**BLANK**

**INVENTEC**

TITLE			
TAOS20			
BLANK			
SIZE	CODE	DOC. NUMBER	REV
A3	CS	1310A20305	A02

CHANGE by *Drawer Name* 20-Apr-2006

SHEET 14 OF 69

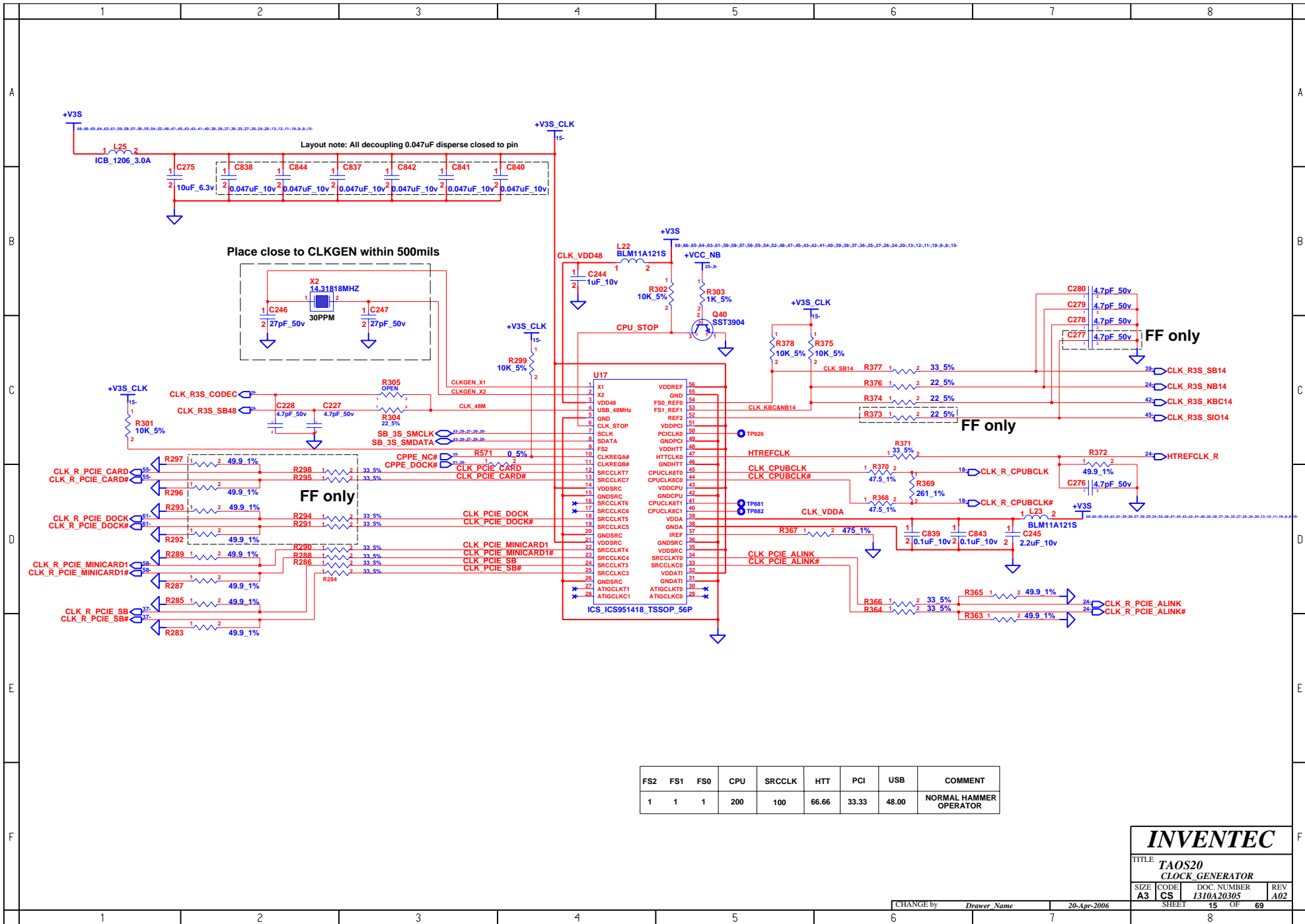

# INVENTEC

TITLE TAOS20 CLOCK_GENERATOR			
SIZE A3	CODE CS	DOC. NUMBER I310A20305	REV A02
CHANGE by Drawer Name		20-Apr-2006	
SHEET 15		OF 69	

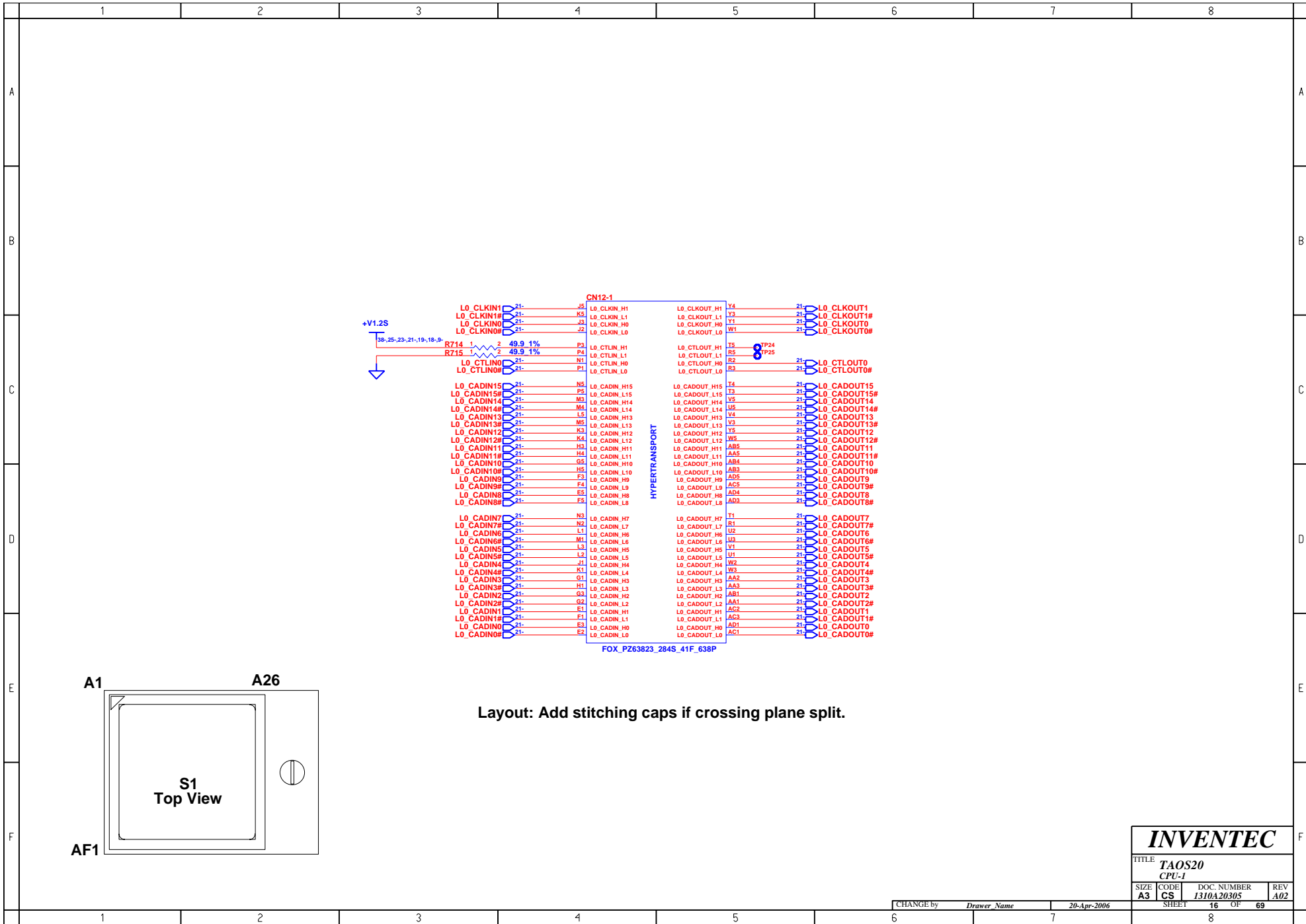

Layout: Add stitching caps if crossing plane split.

**INVENTEC**

TITLE  
**TAOS20**  
 CPU-1

SIZE <b>A3</b>	CODE <b>CS</b>	DOC. NUMBER <b>1310A20305</b>	REV <b>A02</b>
-------------------	-------------------	----------------------------------	-------------------



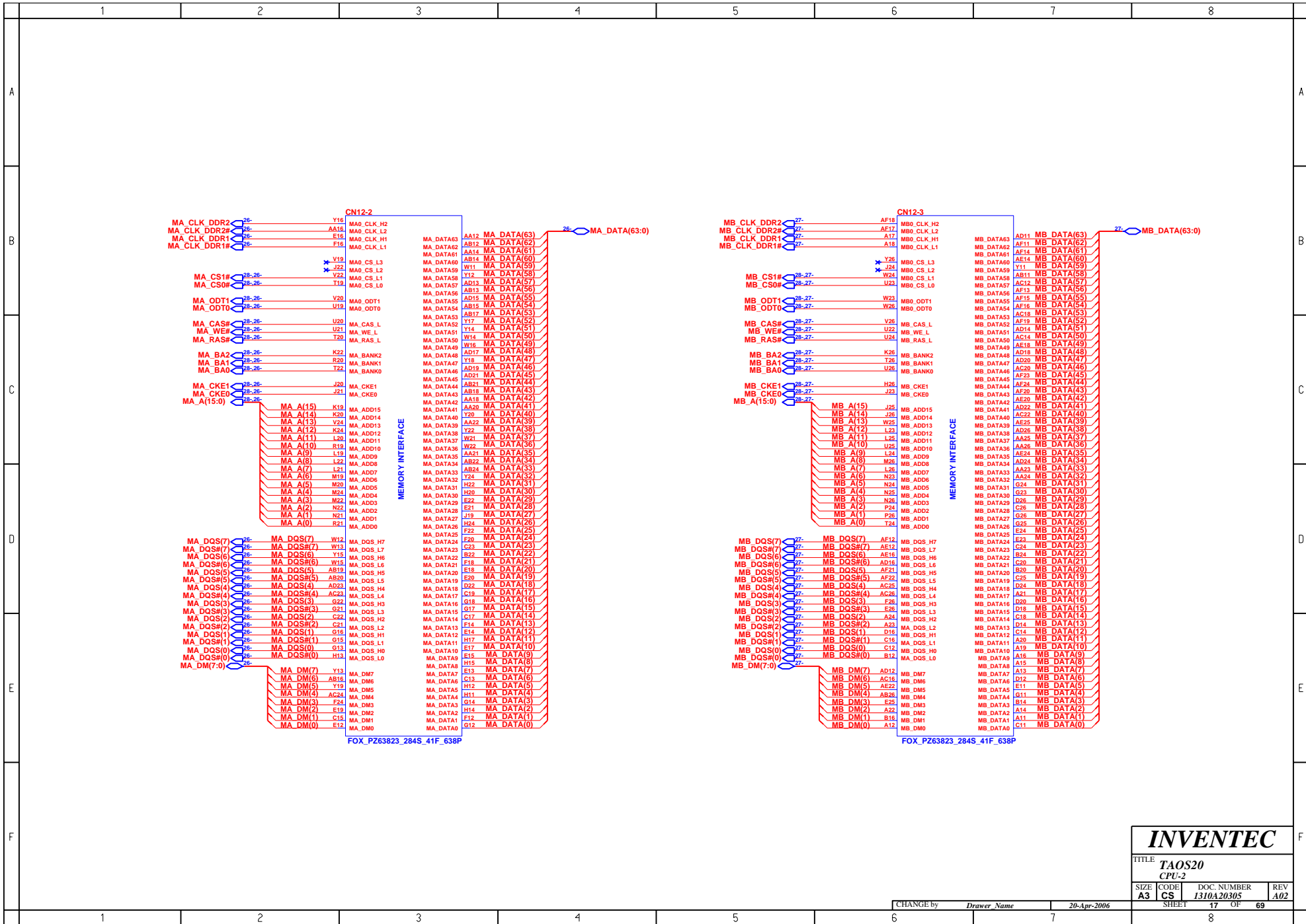

<b>INVENTEC</b>			
TITLE TAOS20 CPU-2			
SIZE A3	CODE CS	DOC. NUMBER 1310A20305	REV A02
CHANGE by Drawer Name		20-Apr-2006	
SHEET 17		OF 69	

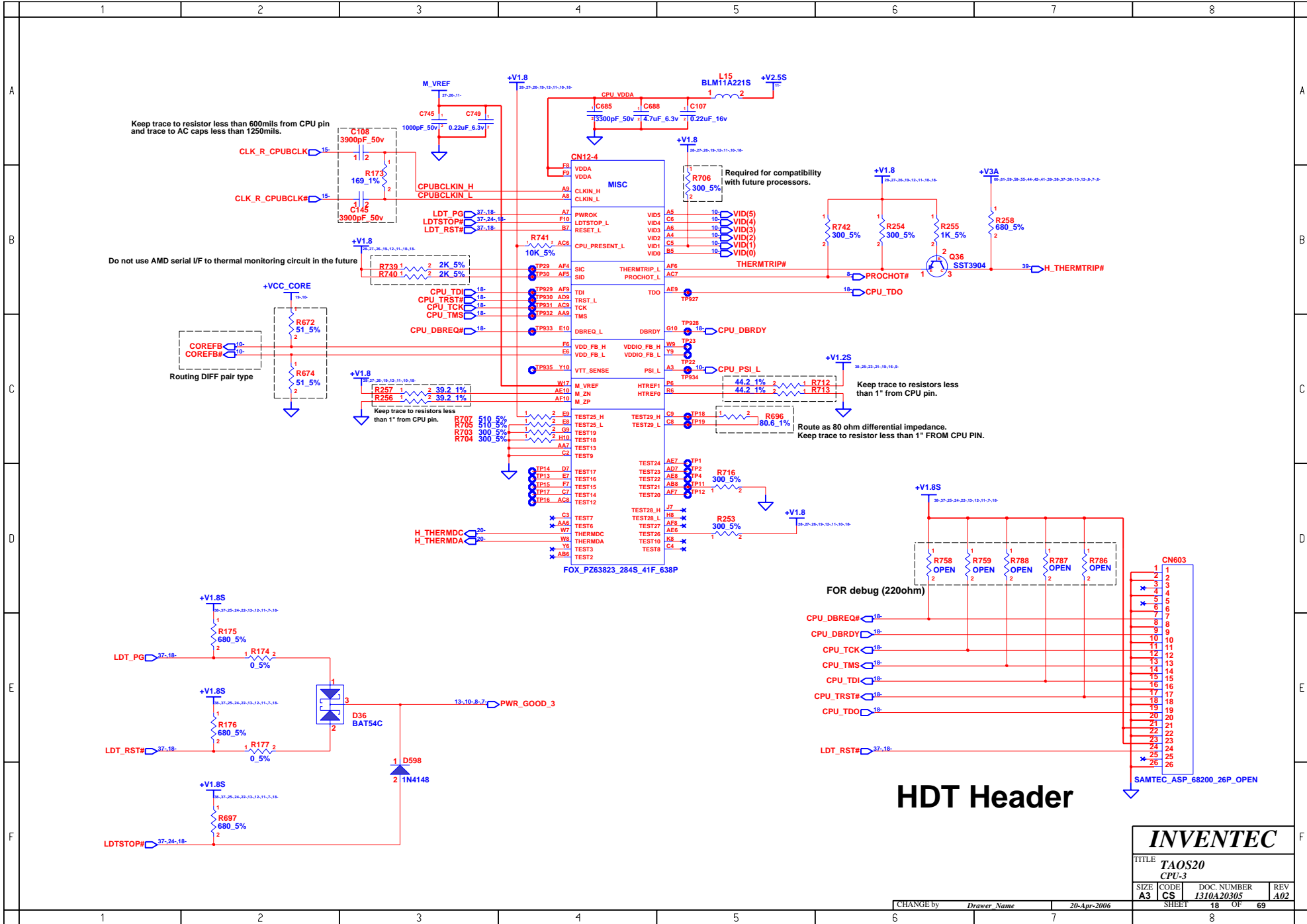

# HDT Header

<b>INVENTEC</b>			
TITLE <b>TAOS20 CPU-3</b>			
SIZE <b>A3</b>	CODE <b>CS</b>	DOC. NUMBER <b>I310A20305</b>	REV <b>A02</b>
CHANGE by <i>Drawer Name</i>		20-Apr-2006	
SHEET		18 OF 69	

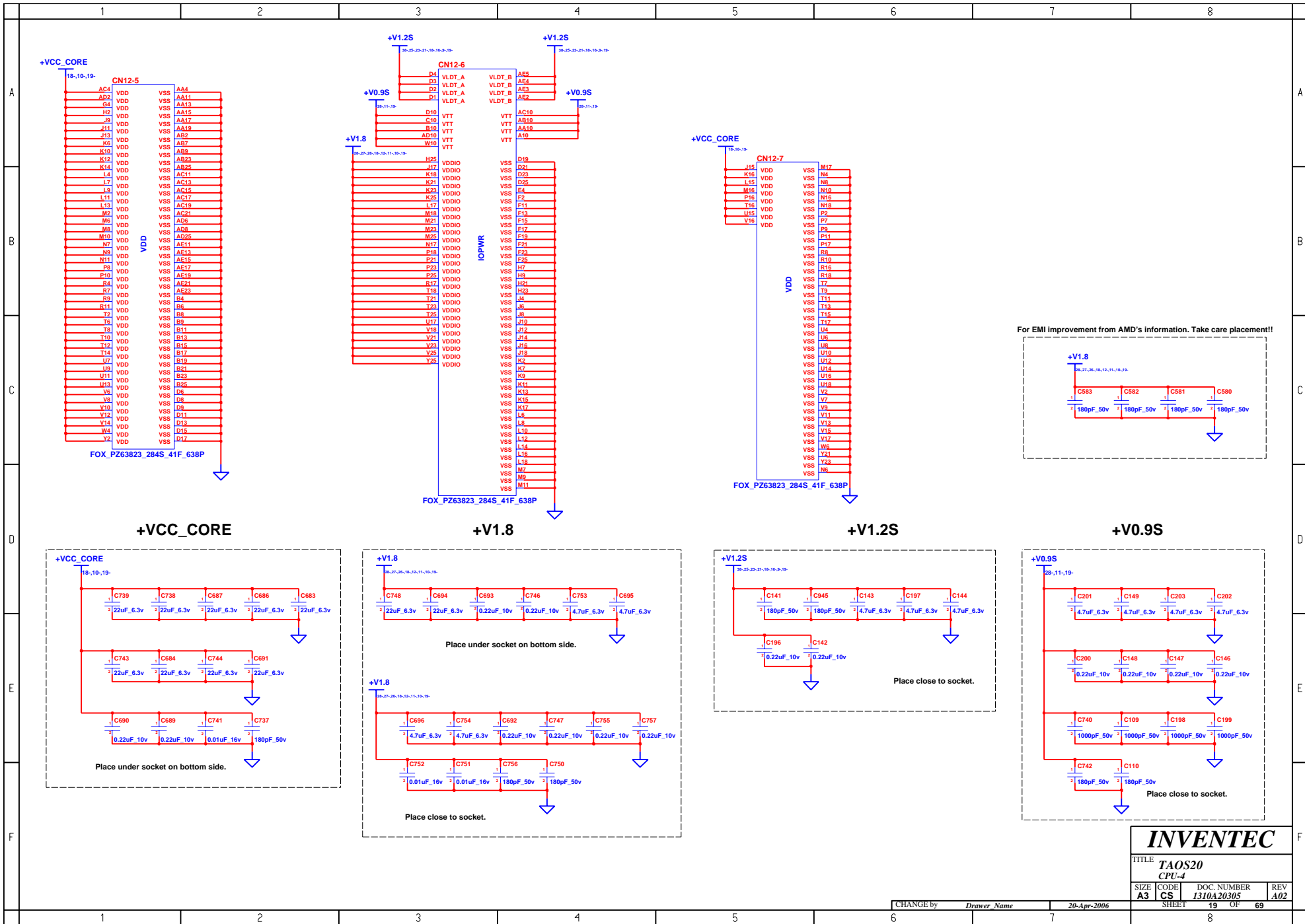

# INVENTEC

TITLE			
TAOS20			
CPU-4			
SIZE	CODE	DOC. NUMBER	REV
A3	CS	I310A20305	A02
CHANGE by		Drawer Name	20-Apr-2006
SHEET		19	OF 69

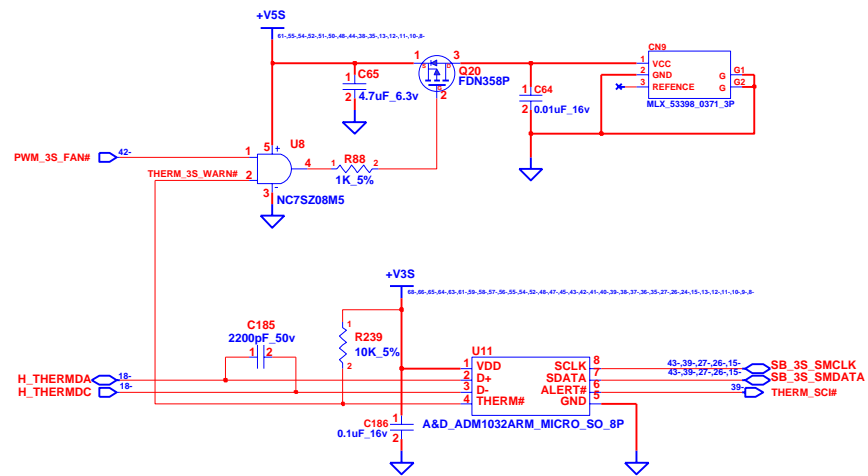

**LAYOUT Note: Put the thermal sensor close to CPU.**

<b>INVENTEC</b>			
TITLE <b>TAOS20 THERMAL&amp;FAN CONTROLLER</b>			
SIZE <b>A3</b>	CODE <b>CS</b>	DOC. NUMBER <b>1310A20305</b>	REV <b>A01</b>
CHANGE by <i>Drawer Name</i>		20-Apr-2006	SHEET 20 OF 69

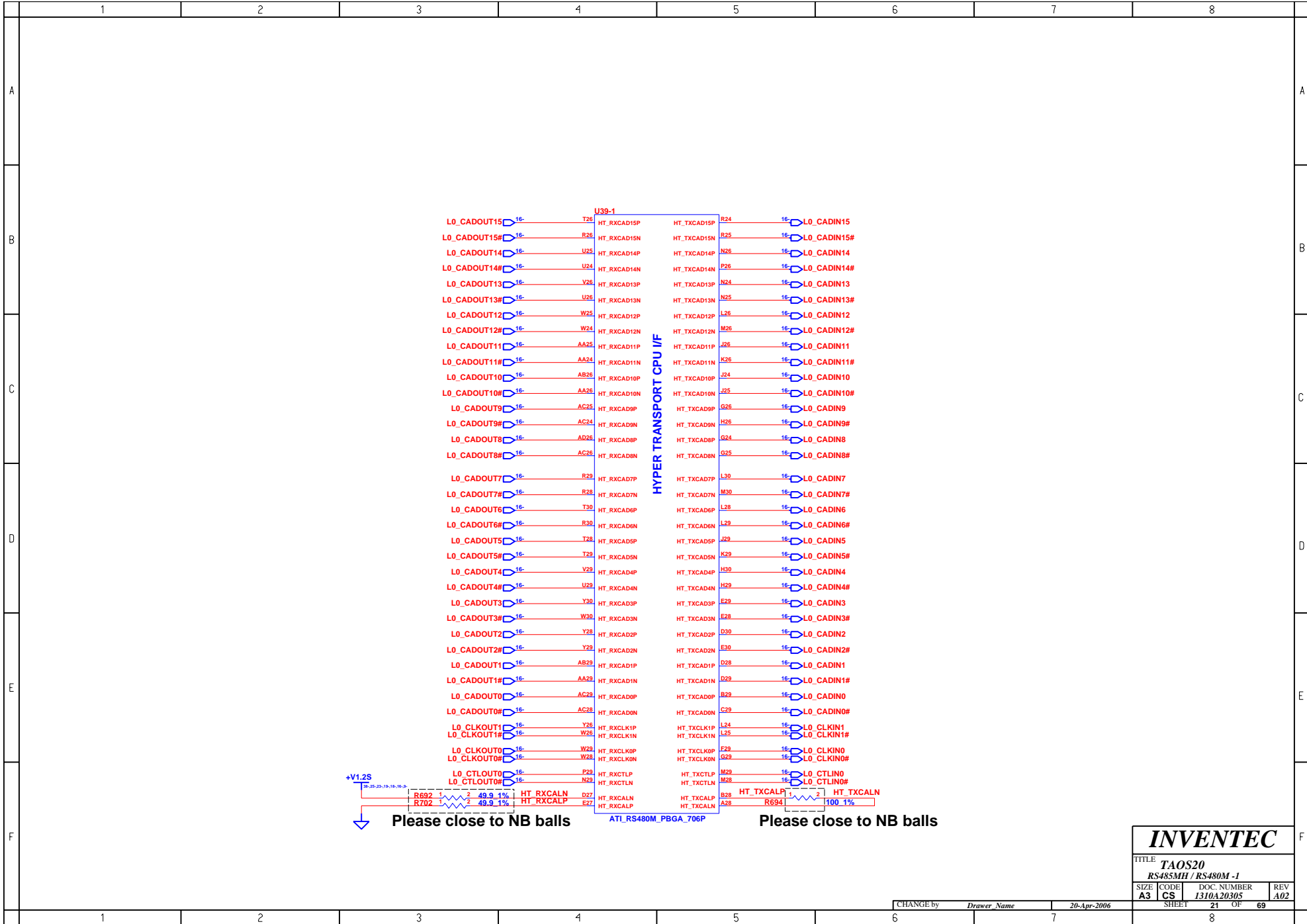

**INVENTEC**

TITLE **TAOS20**  
RS485MH / RS480M -1

SIZE CODE DOC. NUMBER REV  
A3 CS 1310A20305 A02

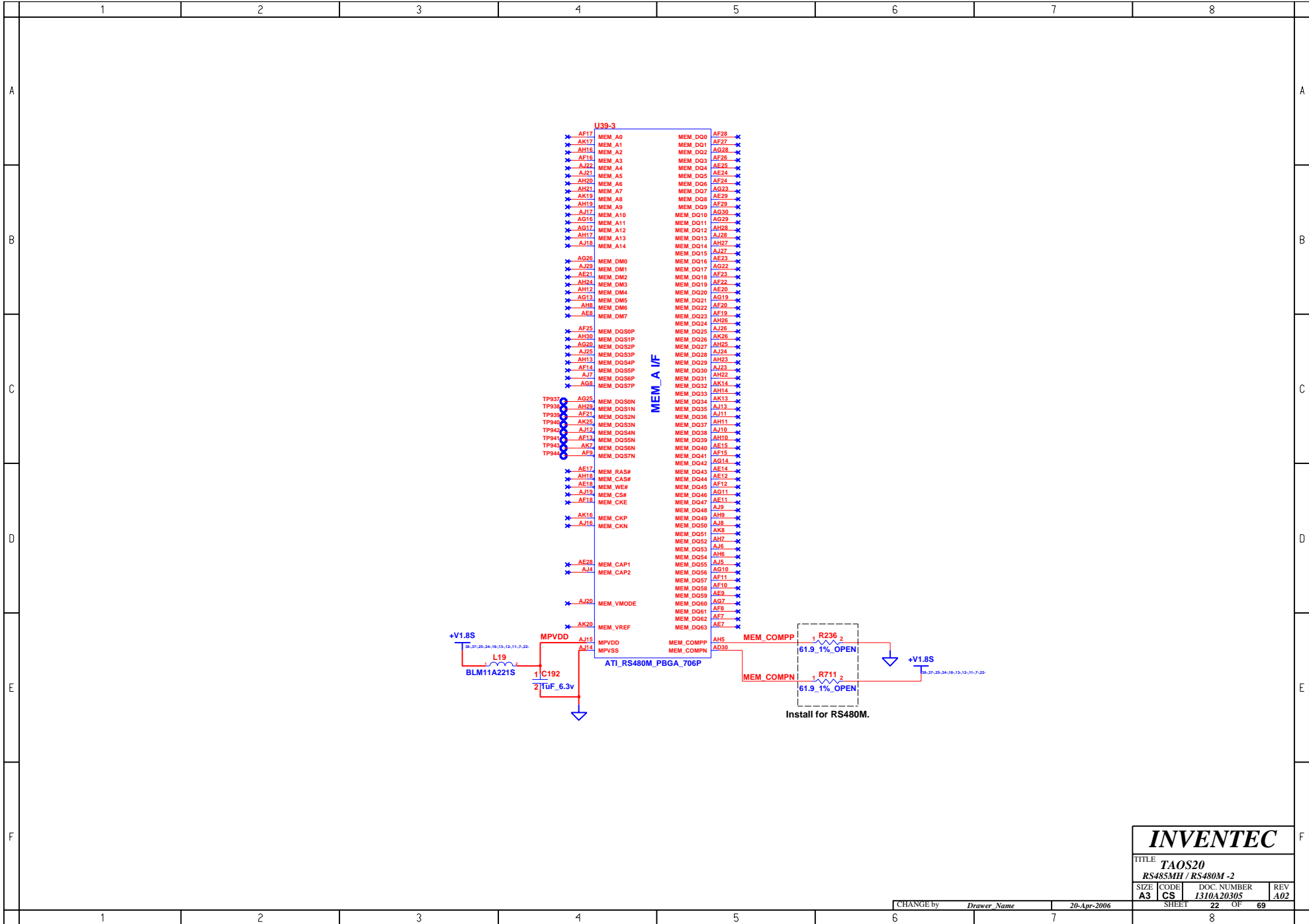

# INVENTEC

TITLE TAOS20  
RS485MH / RS480M -2

SIZE	CODE	DOC. NUMBER	REV
A3	CS	1310A20305	A02

CHANGE by *Drawer Name* 20-Apr-2006

SHEET 22 OF 69

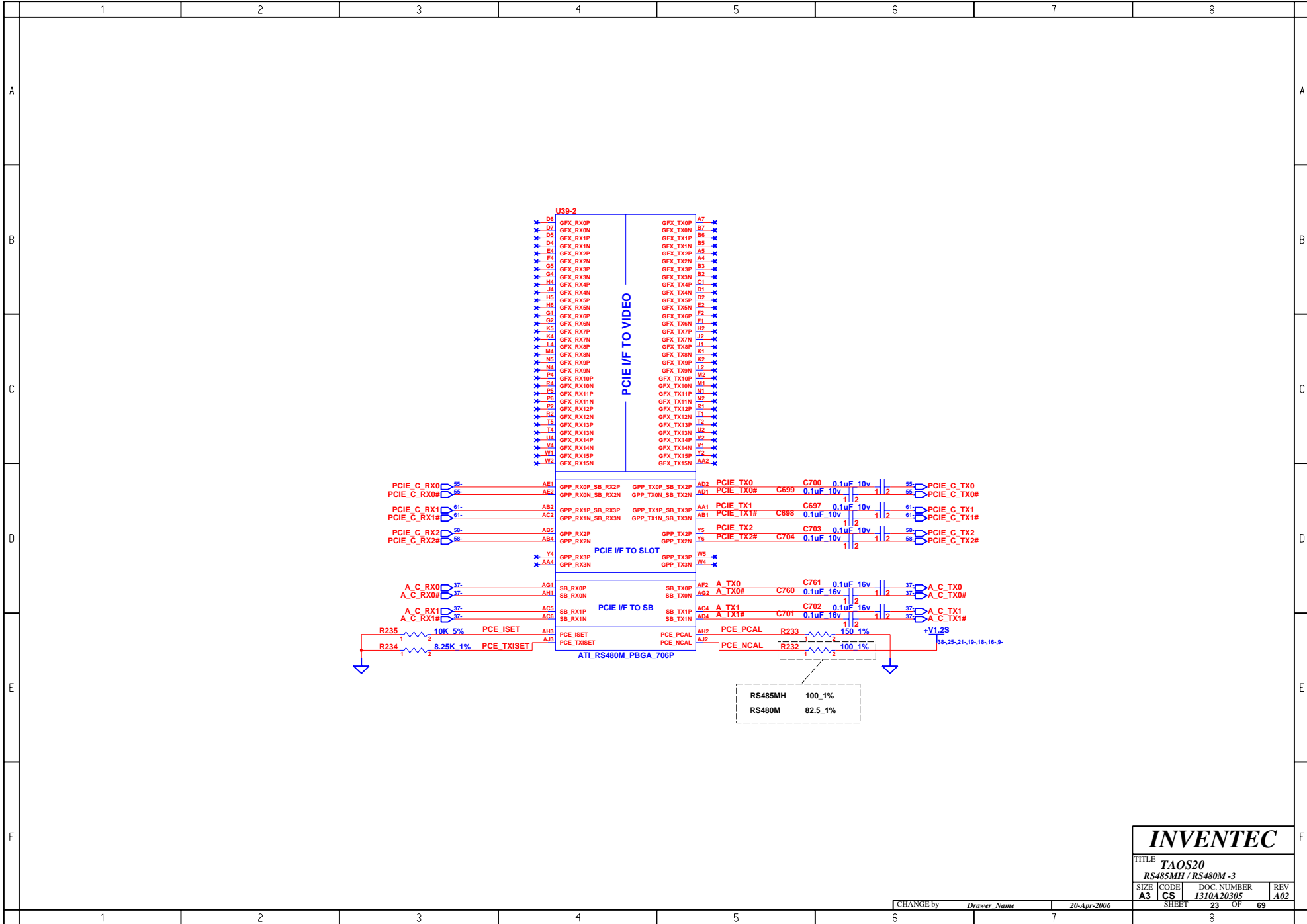

**INVENTEC**

TITLE TAOS20			
RS485MH / RS480M -3			
SIZE	CODE	DOC. NUMBER	REV
A3	CS	1310A20305	A02

CHANGE by	Drawer Name	20-Apr-2006	SHEET 23 OF 69
-----------	-------------	-------------	----------------

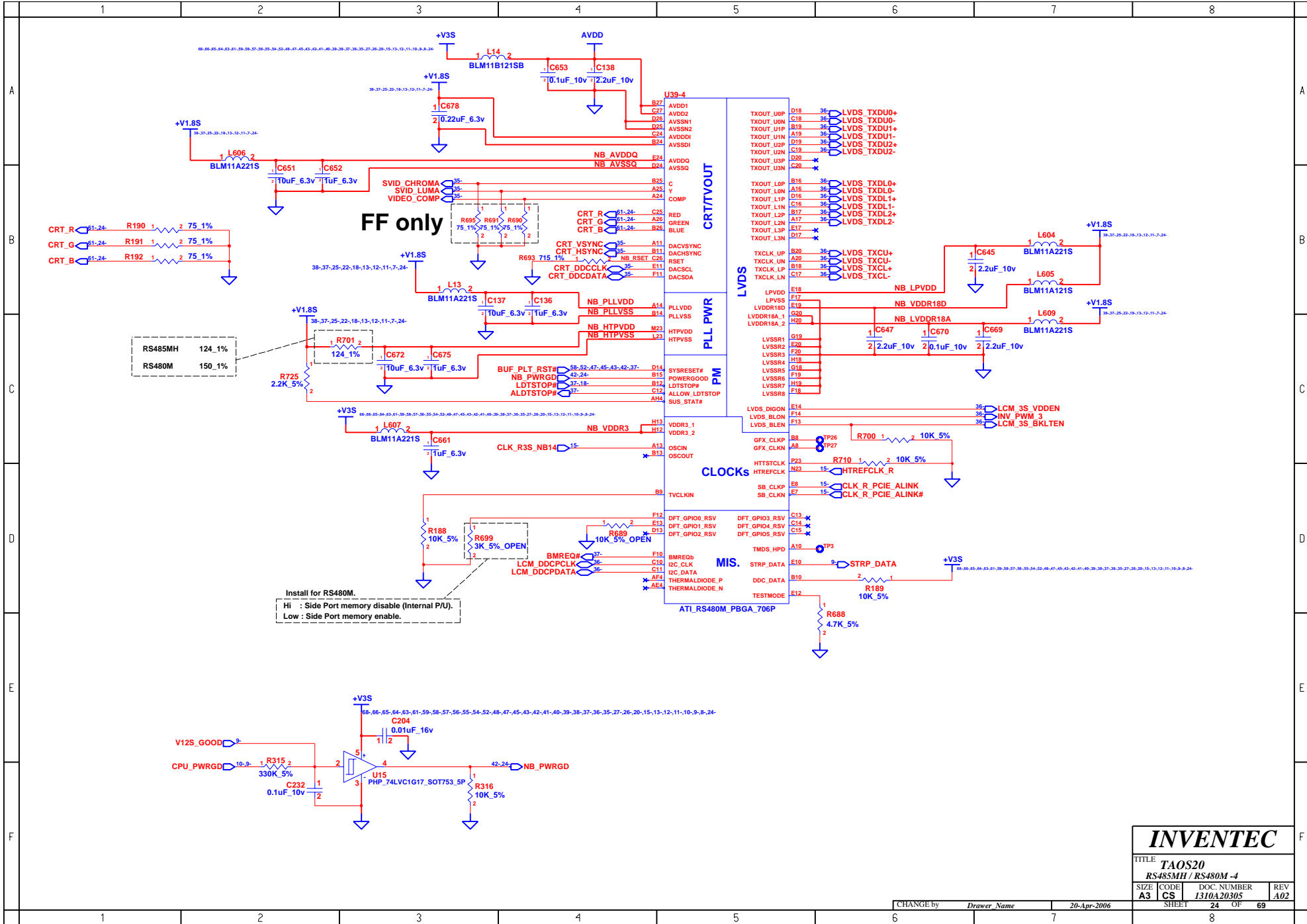

<b>INVENTEC</b>			
TITLE TAOS20			
RS485MH / RS480M -4			
SIZE	CODE	DOC. NUMBER	REV
A3	CS	1310A20305	A02
CHANGE by <i>Drawer Name</i>			20-Apr-2006
SHEET 24			OF 69



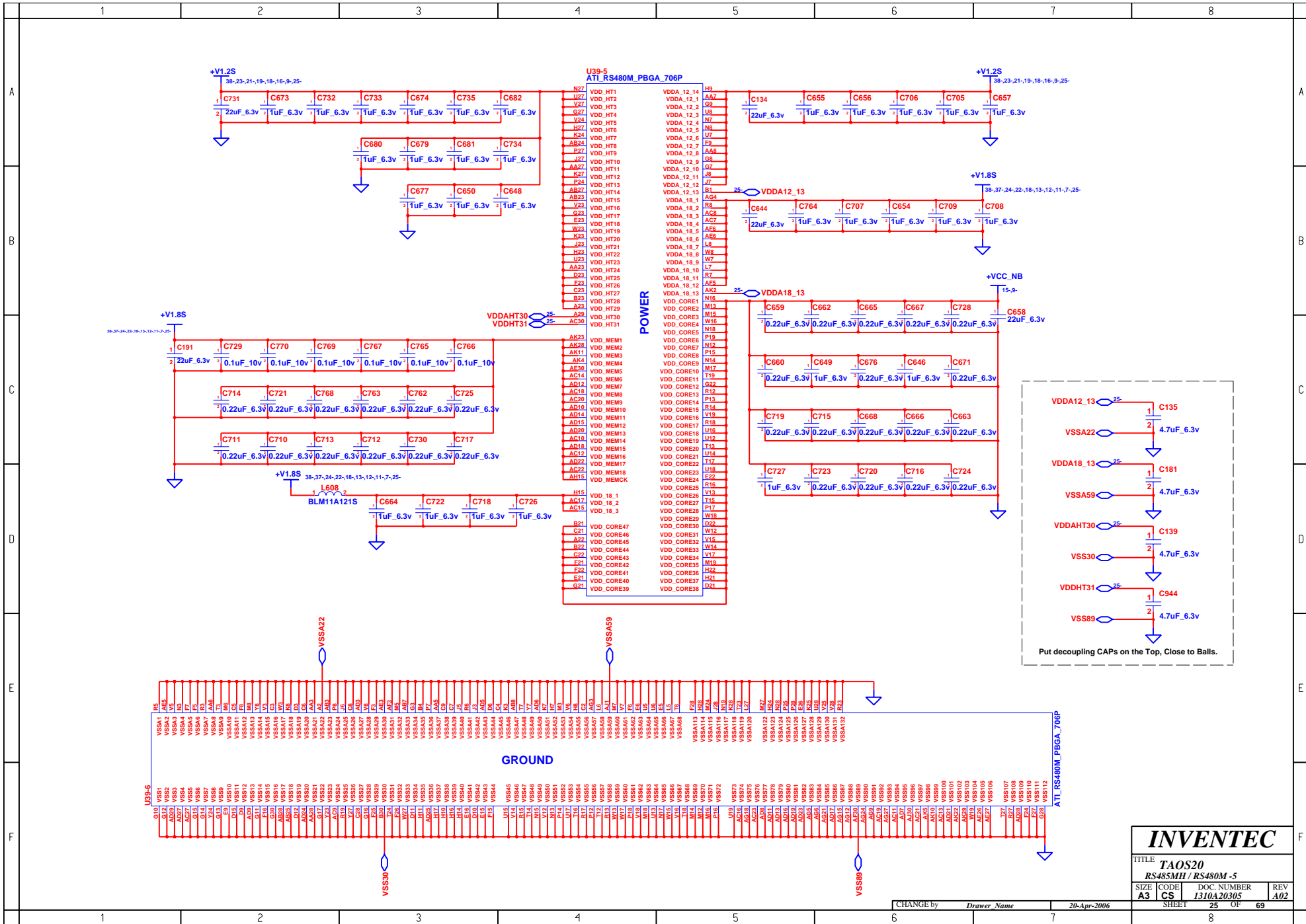

# INVENTEC

TITLE  
**TAOS20**  
 RS485MH / RS480M -5

SIZE	CODE	DOC. NUMBER	REV
A3	CS	1310A20305	A02

CHANGE by *Drawer Name* 20-Apr-2006

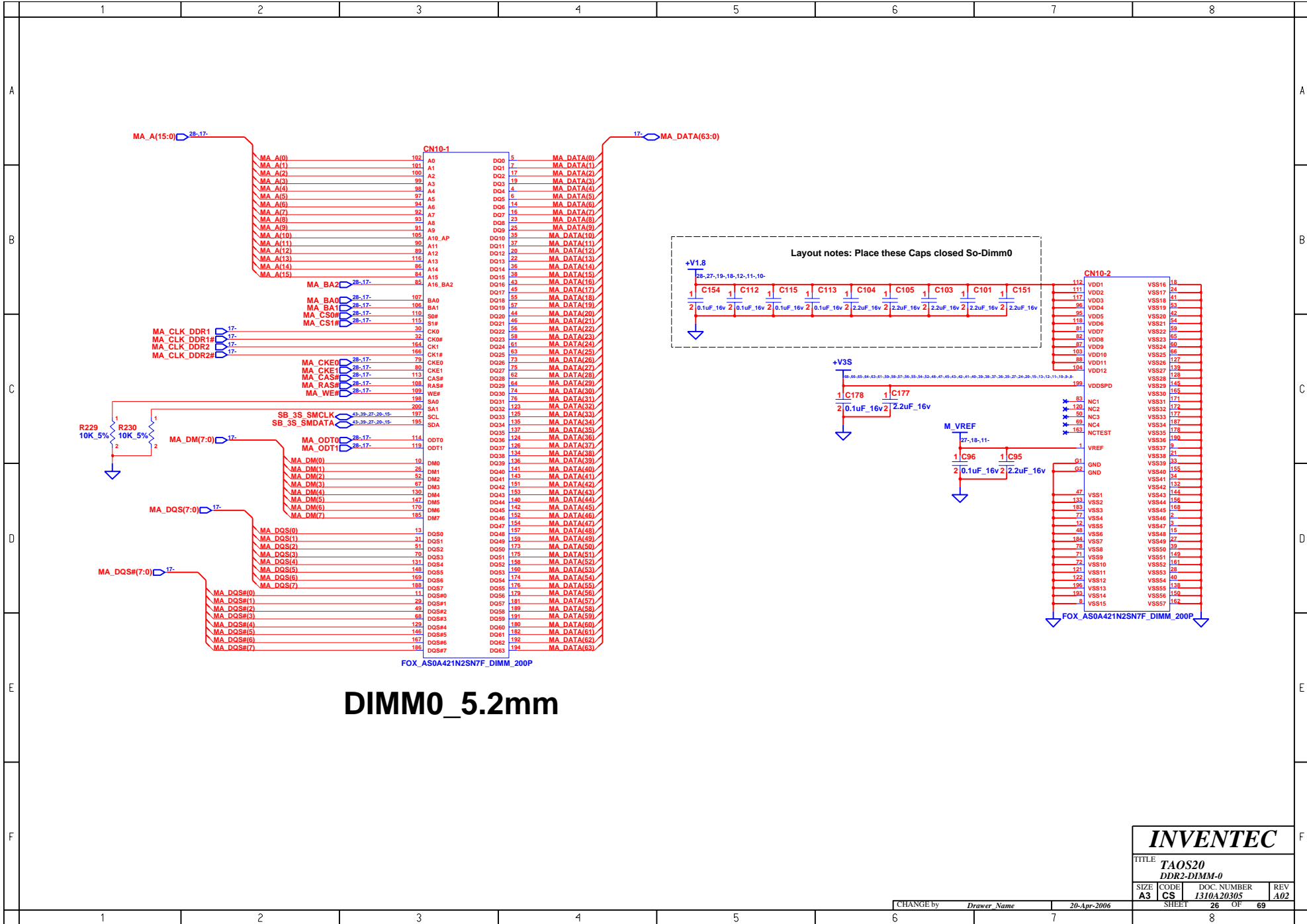

<b>INVENTEC</b>			
TITLE TAOS20 DDR2-DIMM-0			
SIZE A3	CODE CS	DOC. NUMBER I310A20305	REV A02
CHANGE by Drawer Name		20-Apr-2006	
SHEET 26		OF 69	

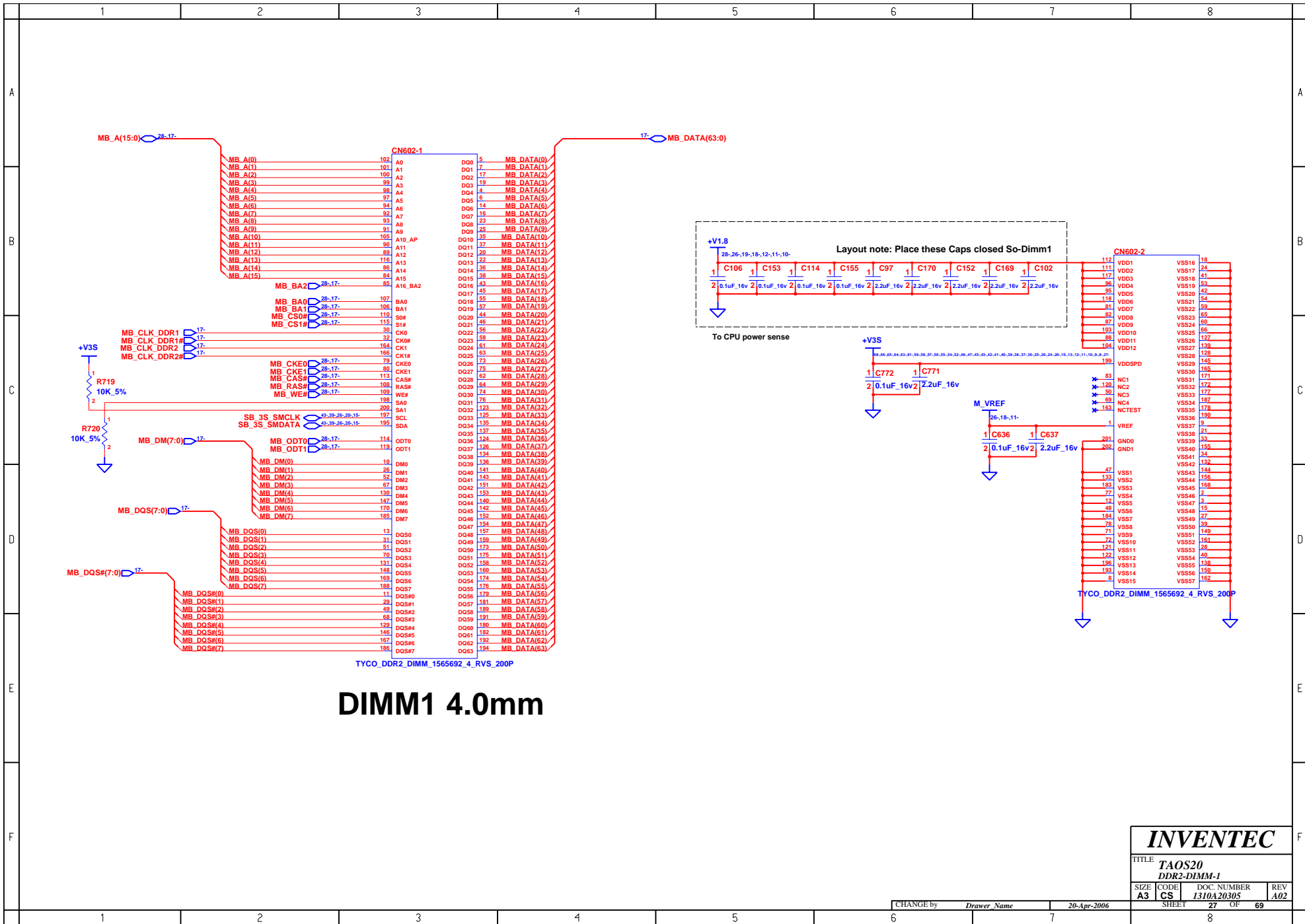

<b>INVENTEC</b>			
TITLE TAOS20 DDR2-DIMM-1			
SIZE A3	CODE CS	DOC. NUMBER 1310A20305	REV A02
CHANGE by Drawer Name		20-Apr-2006	
SHEET 27		OF 69	

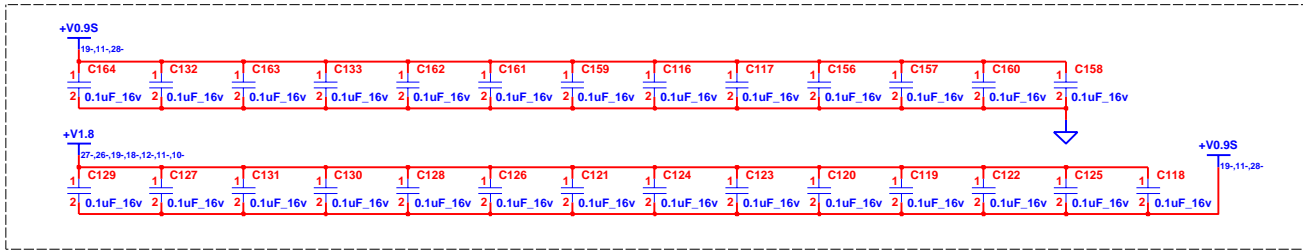

To CPU power sense

### Place CAPs close to DIMM

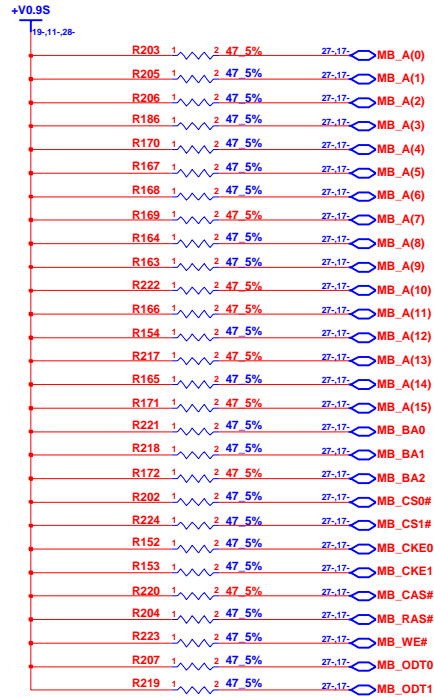
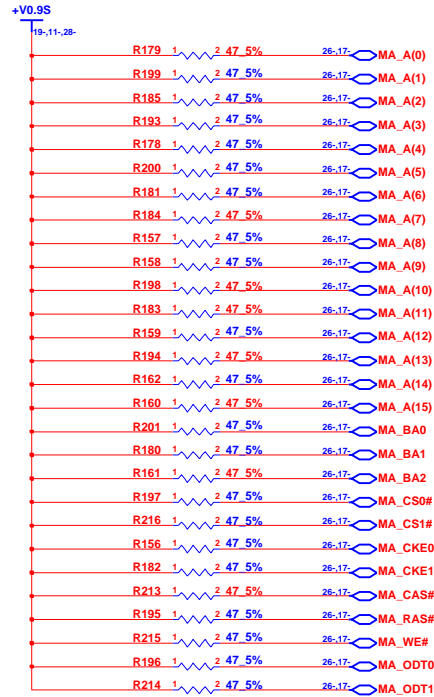

## INVENTEC

TITLE			
TAOS20			
DDR2-DAMPING			
SIZE	CODE	DOC. NUMBER	REV
A3	CS	I310A20305	A02
CHANGE by		SHEET	
Drawer Name		28 OF 69	

20-Apr-2006

# BLANK

<b>INVENTEC</b>			
TITLE <b>TAOS20</b>			
BLANK			
SIZE <b>A3</b>	CODE <b>CS</b>	DOC. NUMBER <b>I310A20305</b>	REV <b>A02</b>
CHANGE by <i>Drawer Name</i>		20-Apr-2006	
SHEET <b>29</b>		OF <b>69</b>	

**BLANK**

**INVENTEC**

TITLE			
TAOS20			
BLANK			
SIZE	CODE	DOC. NUMBER	REV
A3	CS	1310A20305	A02

CHANGE by *Drawer Name* 20-Apr-2006

SHEET 30 OF 69

**BLANK**

**INVENTEC**

TITLE			
TAOS20			
BLANK			
SIZE	CODE	DOC. NUMBER	REV
A3	CS	1310A20305	A02

CHANGE by *Drawer Name* 20-Apr-2006

SHEET 31 OF 69

	1	2	3	4	5	6	7	8	
A									A
B									B
C									C
D									D
E									E
F									F
	1	2	3	4	5	6	7	8	

**BLANK**

**INVENTEC**

TITLE			
<b>TAOS20</b>			
<b>BLANK</b>			
SIZE	CODE	DOC. NUMBER	REV
<b>A3</b>	<b>CS</b>	<b>1310A20305</b>	<b>A02</b>
SHEET		32	OF 69

CHANGE by *Drawer Name* 27-Sep-2003

	1	2	3	4	5	6	7	8	
A									A
B									B
C									C
D									D
E									E
F									F
	1	2	3	4	5	6	7	8	



**BLANK**

**INVENTEC**

TITLE			
TAOS20			
BLANK			
SIZE	CODE	DOC. NUMBER	REV
A3	CS	1310A20305	A02

CHANGE by *Drawer Name* 20-Apr-2006

SHEET 33 OF 69

	1	2	3	4	5	6	7	8	
A									A
B									B
C									C
D									D
E									E
F									F
	1	2	3	4	5	6	7	8	

**BLANK**

**INVENTEC**

TITLE			
TAOS20			
BLANK			
SIZE	CODE	DOC. NUMBER	REV
A3	CS	1310A20305	A02

CHANGE by *Drawer Name* 20-Apr-2006

SHEET 34 OF 69

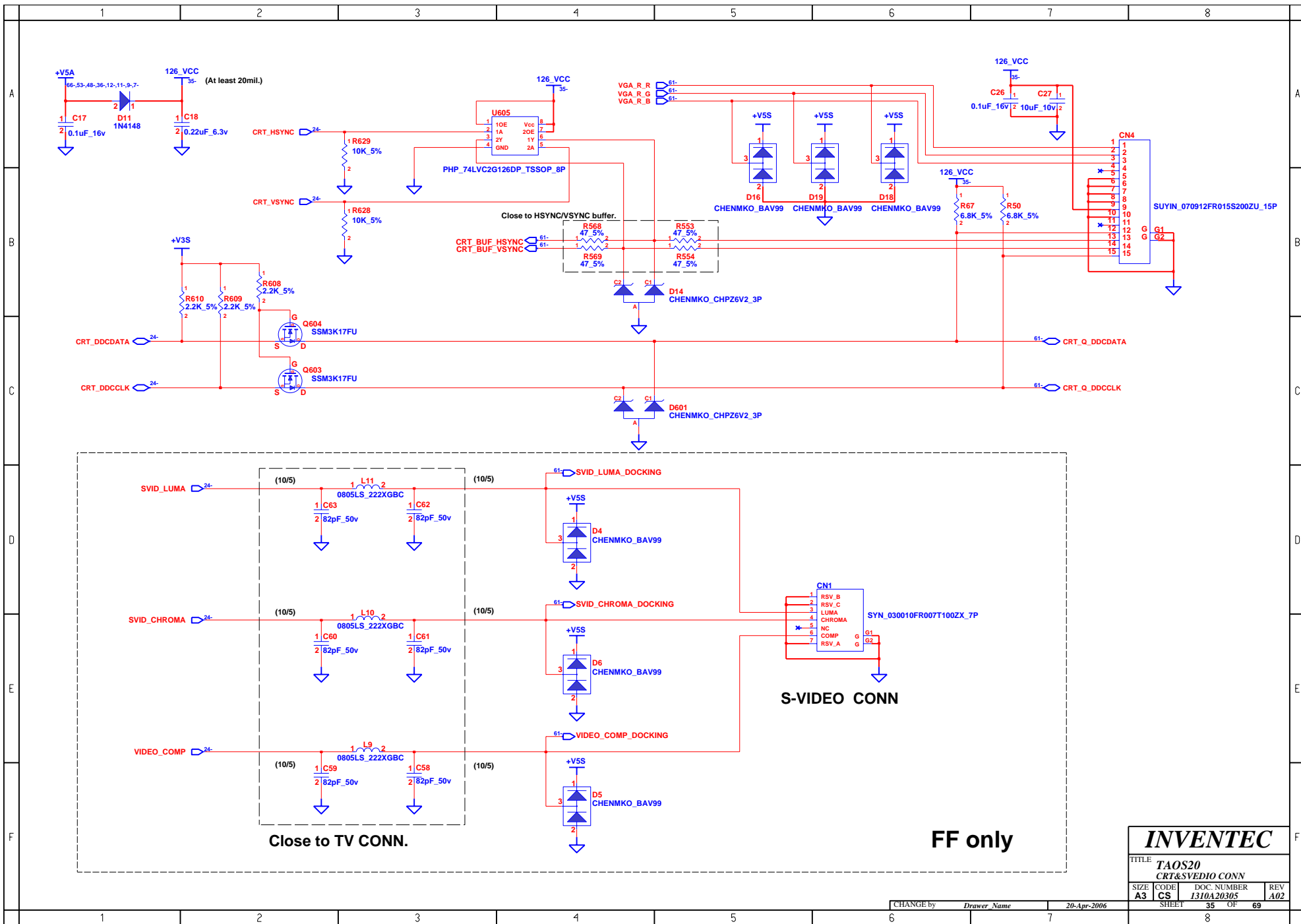

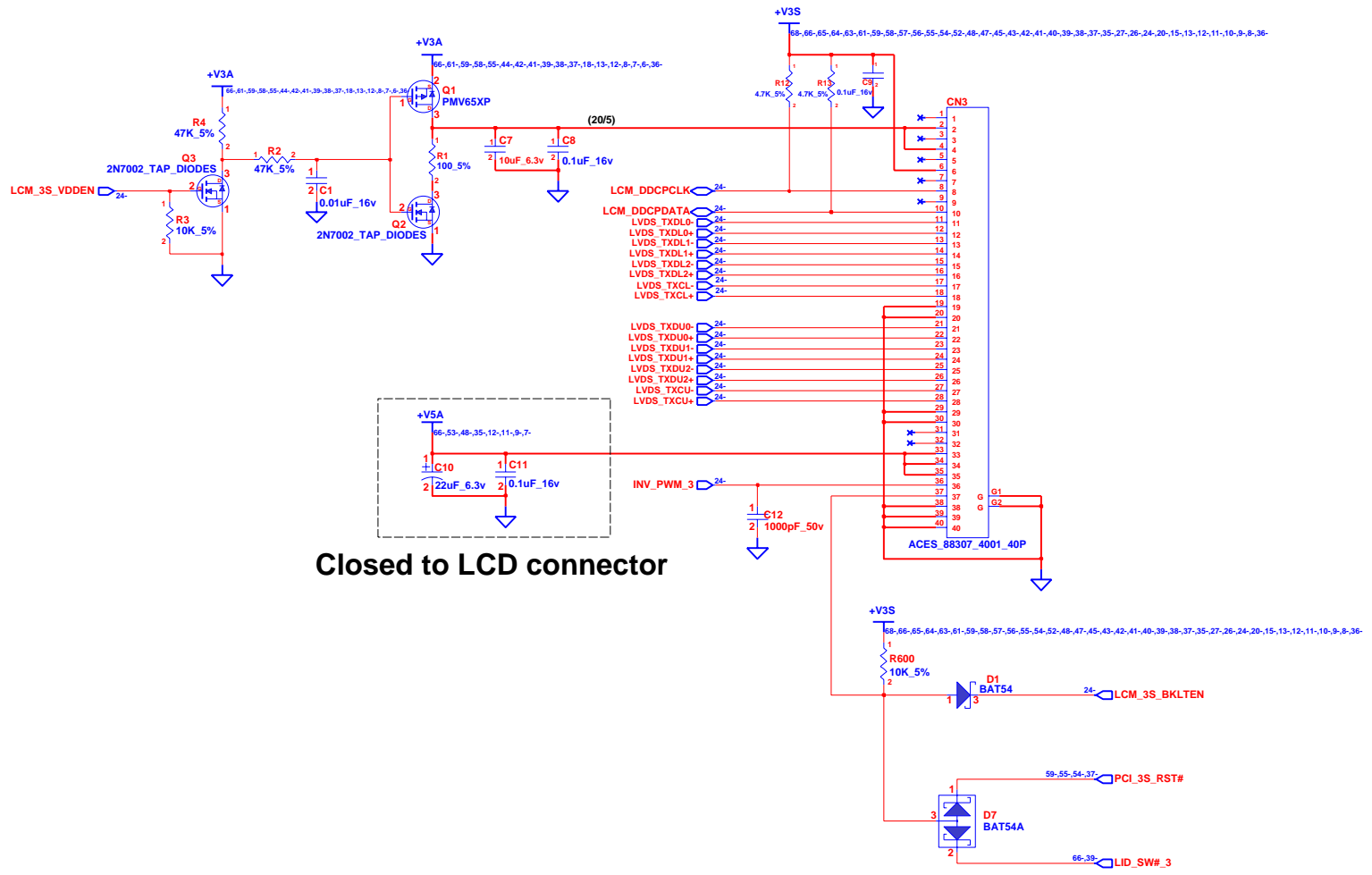

# INVENTEC

TITLE			
TAOS20			
LCD CONN			
SIZE	CODE	DOC. NUMBER	REV
A3	CS	I310A20305	A02

CHANGE by	Drawer Name	20-Apr-2006	SHEET	36	OF	69
-----------	-------------	-------------	-------	----	----	----

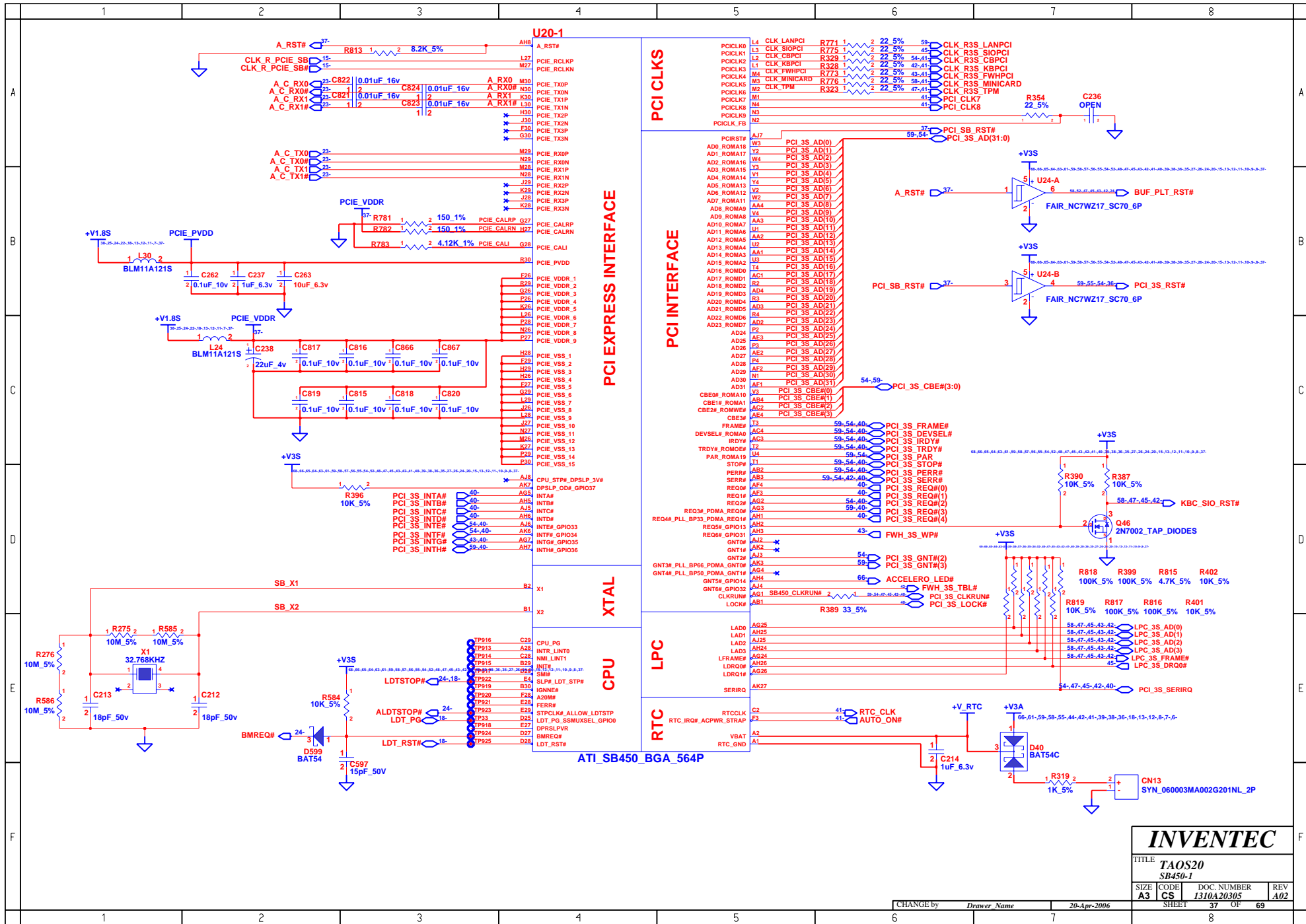

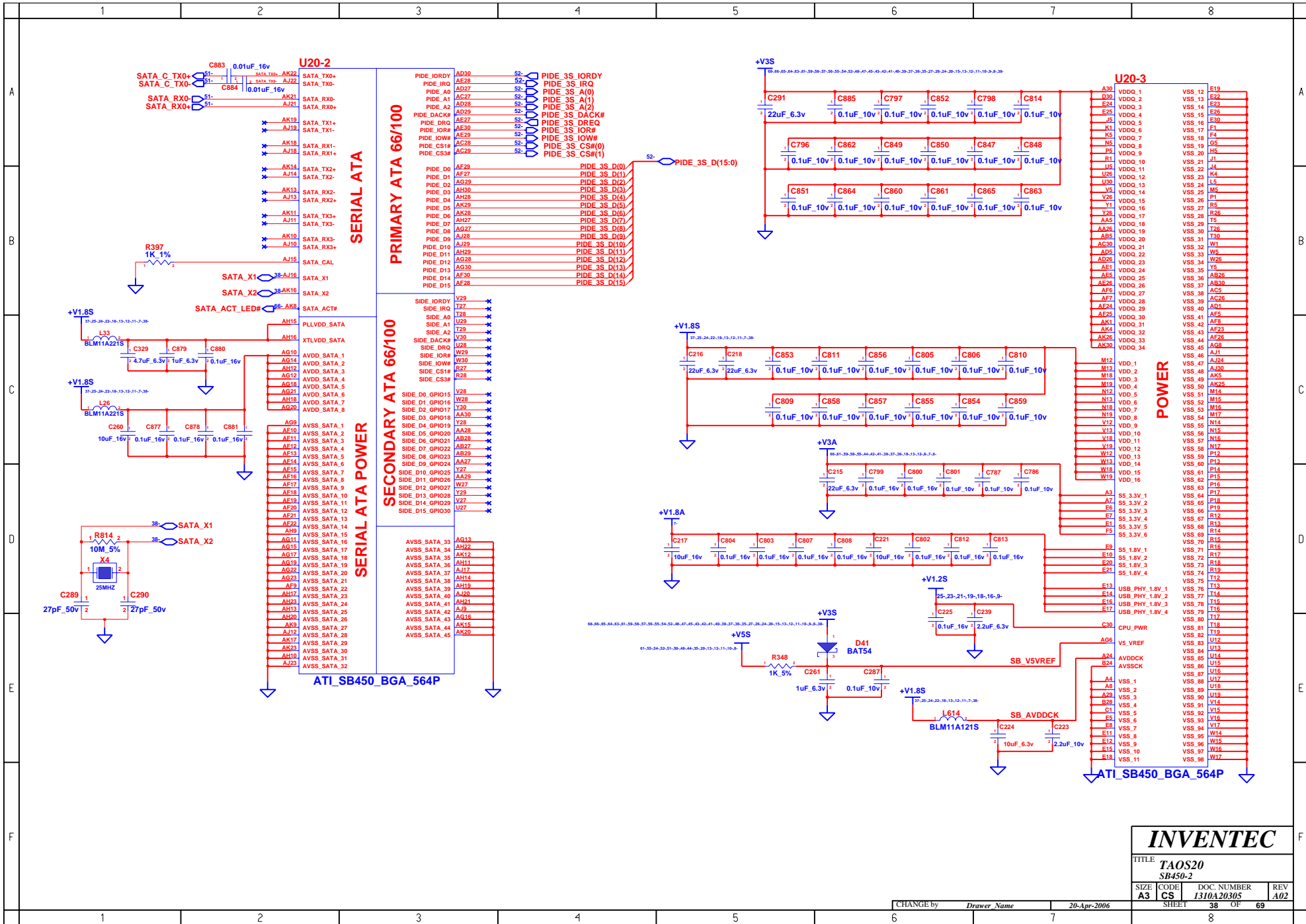

**INVENTEC**

TITLE TAOS20 SB450-2			
SIZE A3	CODE CS	DOC. NUMBER I310A20305	REV A02
CHANGE by Drawer Name		20-Apr-2006	
SHEET 38		OF 69	

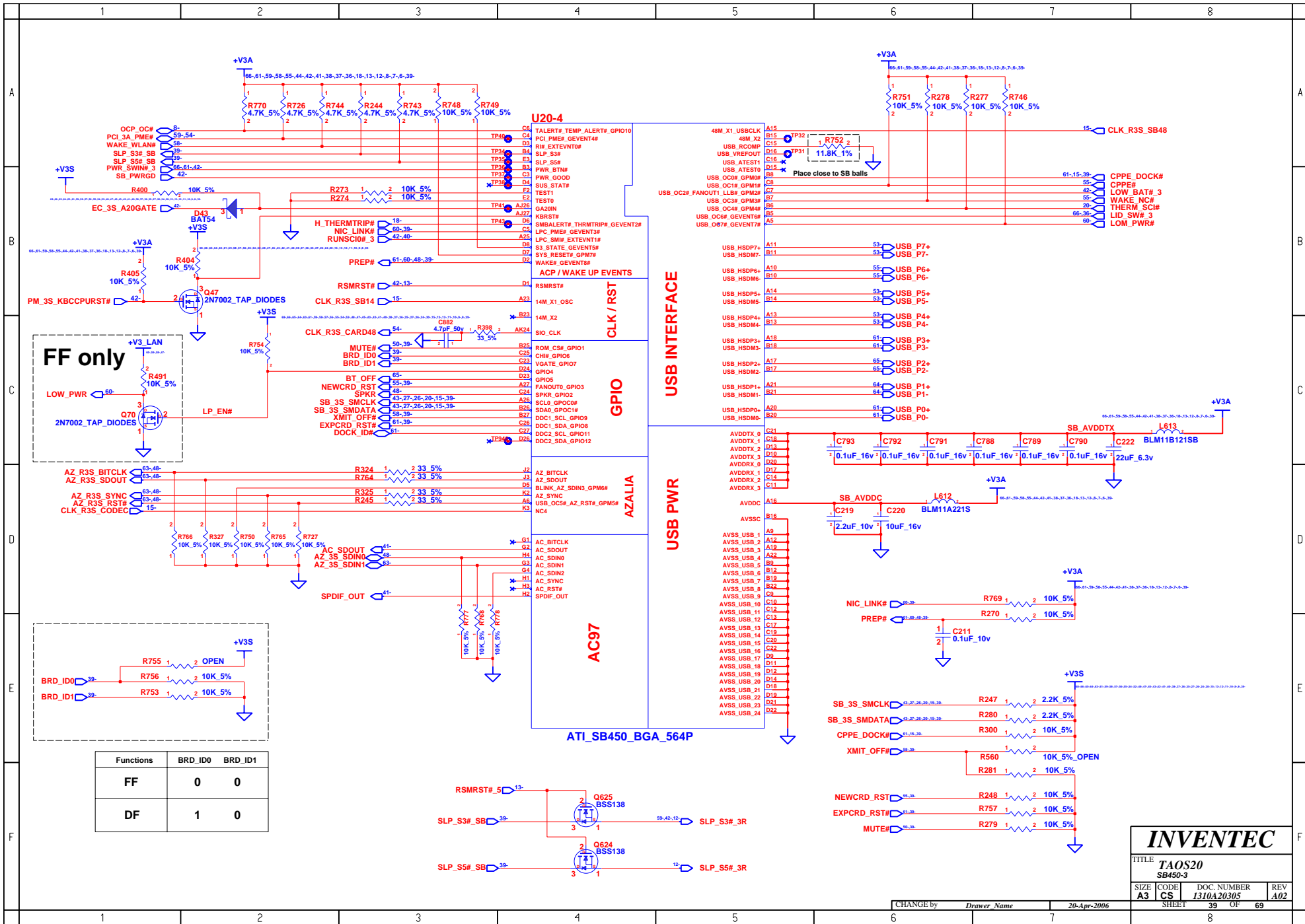

**INVENTEC**

TITLE TAOS20  
SB450-3

SIZE A3	CODE CS	DOC. NUMBER 1310A20305	REV A02
---------	---------	------------------------	---------

CHANGE by *Drawer Name* 20-Apr-2006 SHEET 39 OF 69

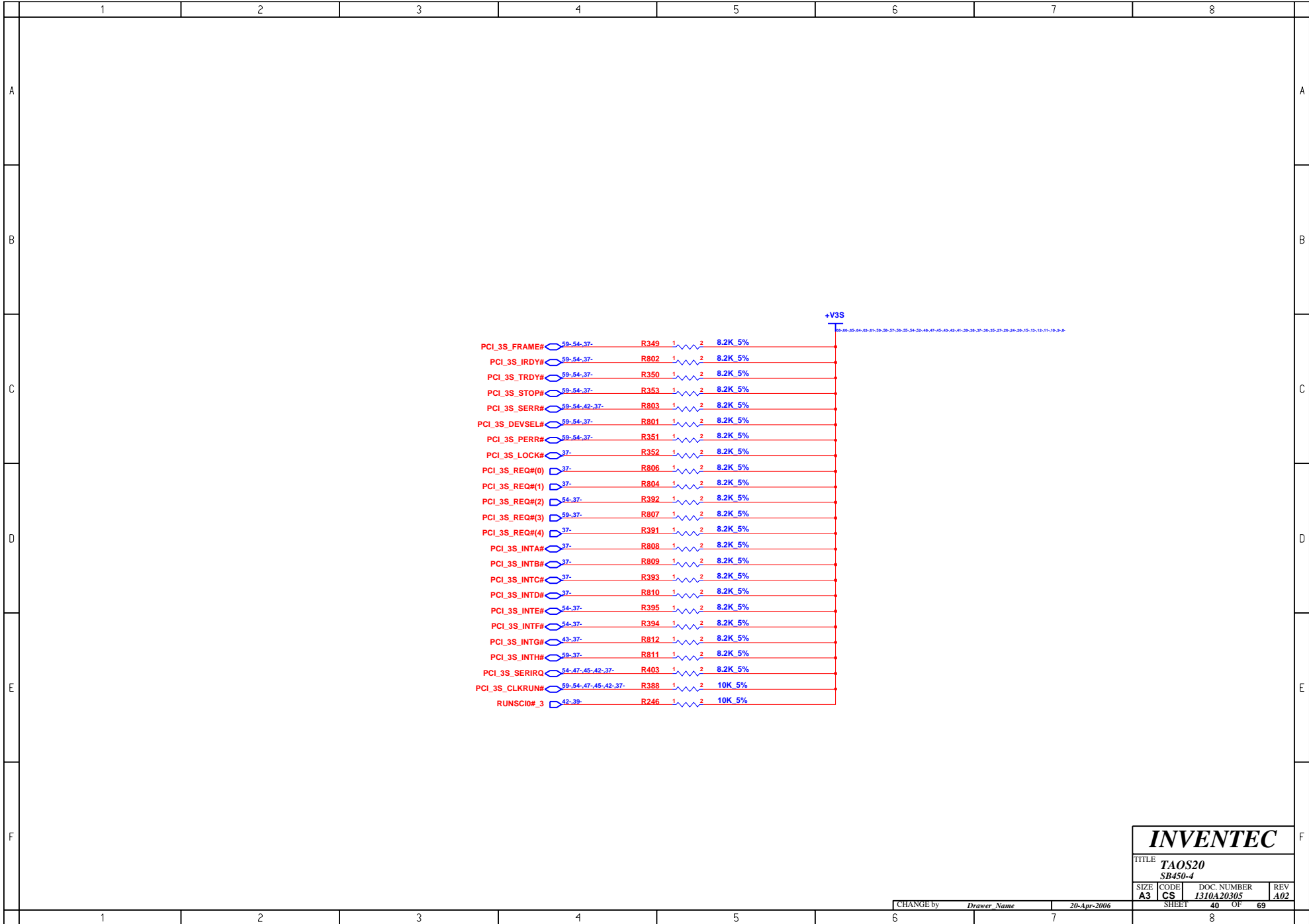

**INVENTEC**

TITLE TAOS20  
SB450-4

SIZE A3	CODE CS	DOC. NUMBER 1310A20305	REV A02
------------	------------	---------------------------	------------

CHANGE by *Drawer Name* 20-Apr-2006

SHEET 40 OF 69



**Required Straps:**

	ACPWRON	AC_SDOUT	RTC_CLK	SPDIF_OUT	CLK_R3S_CBPCI	CLK_R3S_KBPCI	CLK_R3S_FWHPCI	CLK_R3S_MINICARD	PCI_CLK6	PCI_CLK7 PCI_CLK8
<b>PULL HIGH</b>	MANUAL POWER ON ■	USE DEBUG STRAPS	INTERNAL RTC ■	SIO 24MHz	48MHz XTAL	PHY PWRDOWN DISABLE ■	USE INT. PLL48	PCIE CM_SET LOW ■	CPU K8 ■	HH: PCI ROM HL: LPC 1 ROM
<b>PULL LOW</b>	AUTO POWER ON	IGNORE DEBUG STRAPS ■	EXTERNAL RTC	SIO 48MHz ■	48MHz OSC ■	PHY PWRDOWN ENABLE	USE EXT. 48M CLK ■	PCIE CM_SET HIGH	CPU P4	LH: LPC 2 ROM ■ LL: FWH ROM

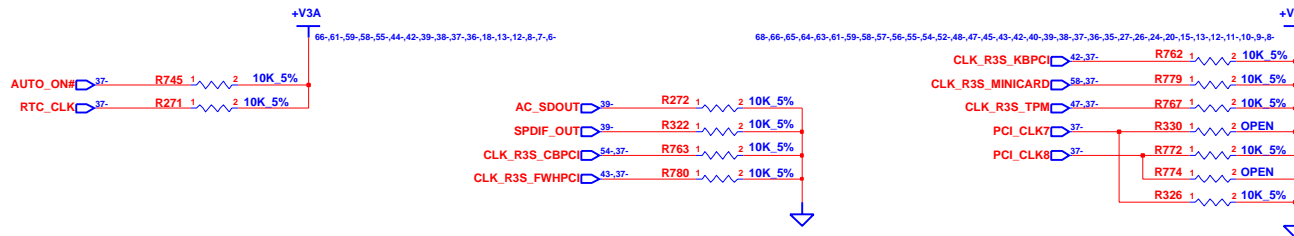

**INVENTEC**

TITLE TAOS20  
SB450-5

SIZE A3	CODE CS	DOC. NUMBER 1310A20305	REV A02
------------	------------	---------------------------	------------

CHANGE by *Drawer Name* 20-Apr-2006

SHEET 41 OF 69

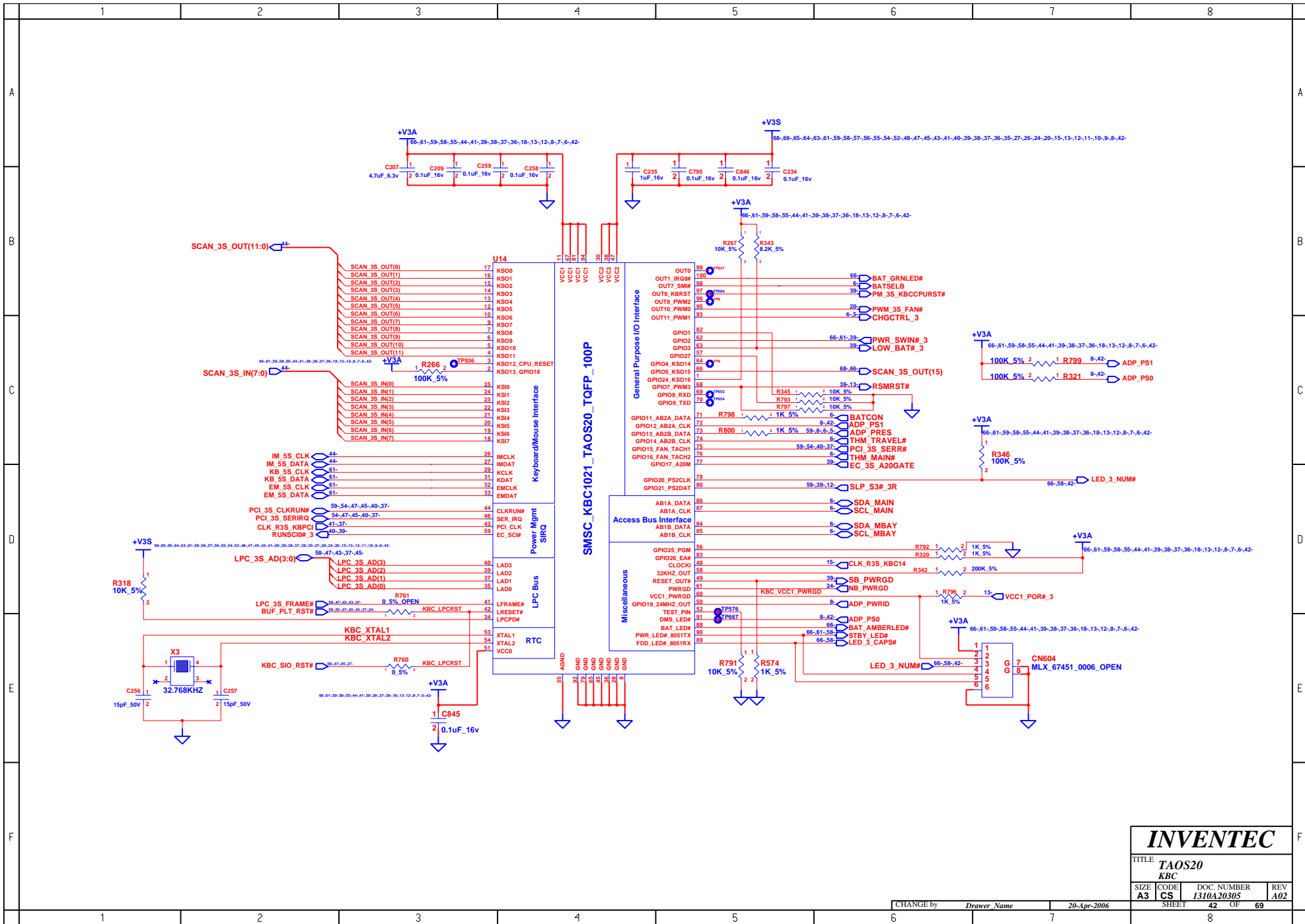

# INVENTEC

TITLE			
TAOS20			
KBC			
SIZE	CODE	DOC. NUMBER	REV
A3	CS	1310A20305	A02

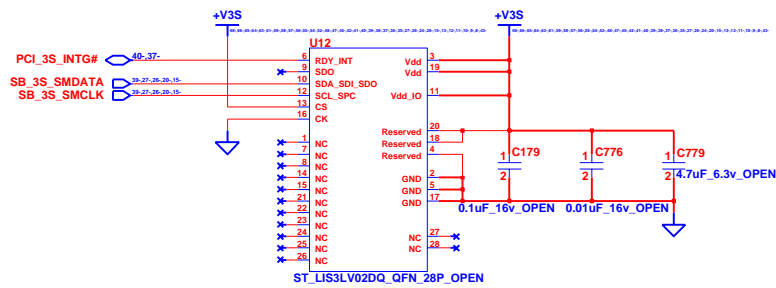
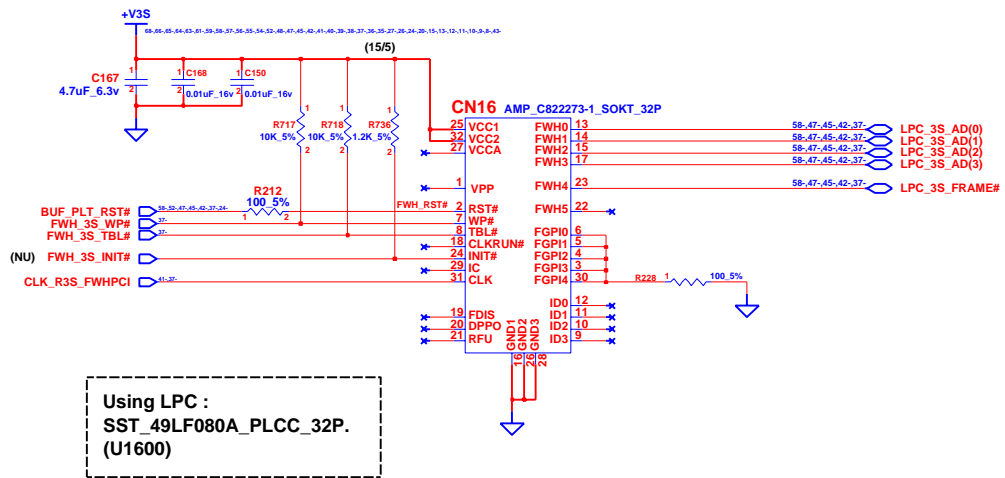

**Accelerometer  
(NI)**

**INVENTEC**

TITLE			
TAOS20			
LPC & Accelerometer(NI)			
SIZE	CODE	DOC. NUMBER	REV
A3	CS	I310A20305	A02

CHANGE by *Drawer Name* 20-Apr-2006

SHEET 43 OF 69

# Keyboard CONN

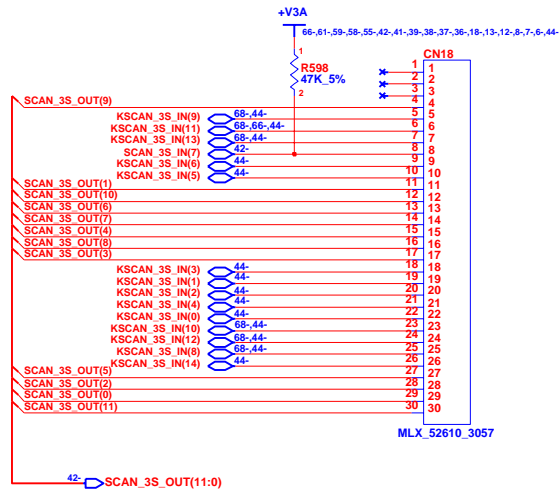

# Touch Pad CONN

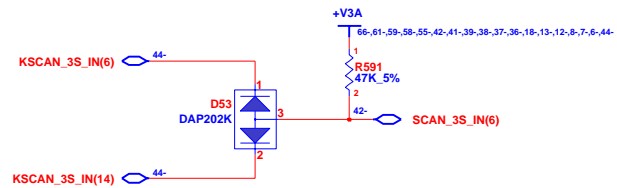
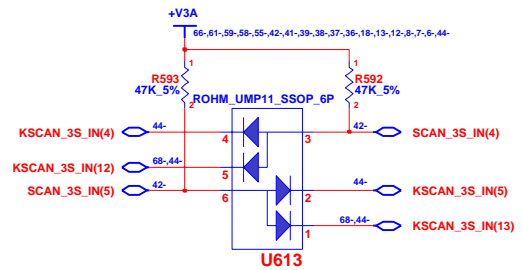
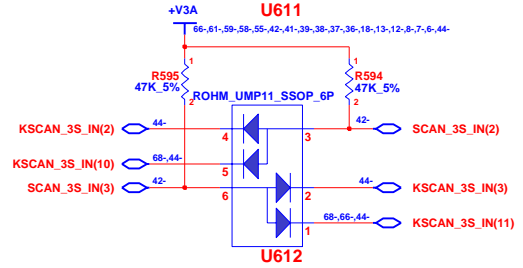
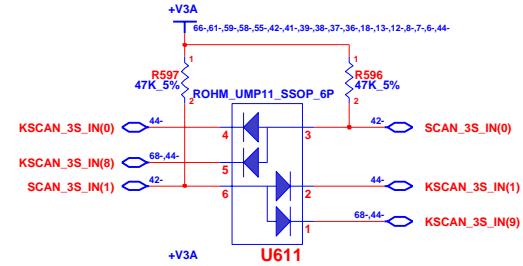
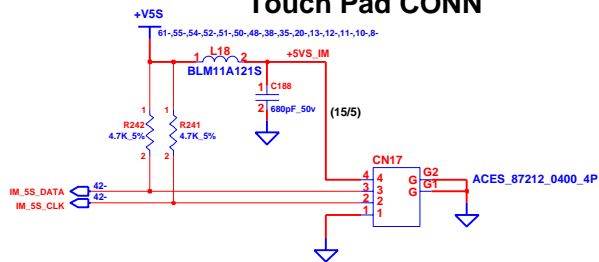

**INVENTEC**

TITLE TAOS20  
INT.KBC/POINT DEVICES

SIZE A3	CODE CS	DOC. NUMBER 1310A20305	REV A02
---------	---------	------------------------	---------

CHANGE by Drawer Name 20-Apr-2006

SHEET 44 OF 69

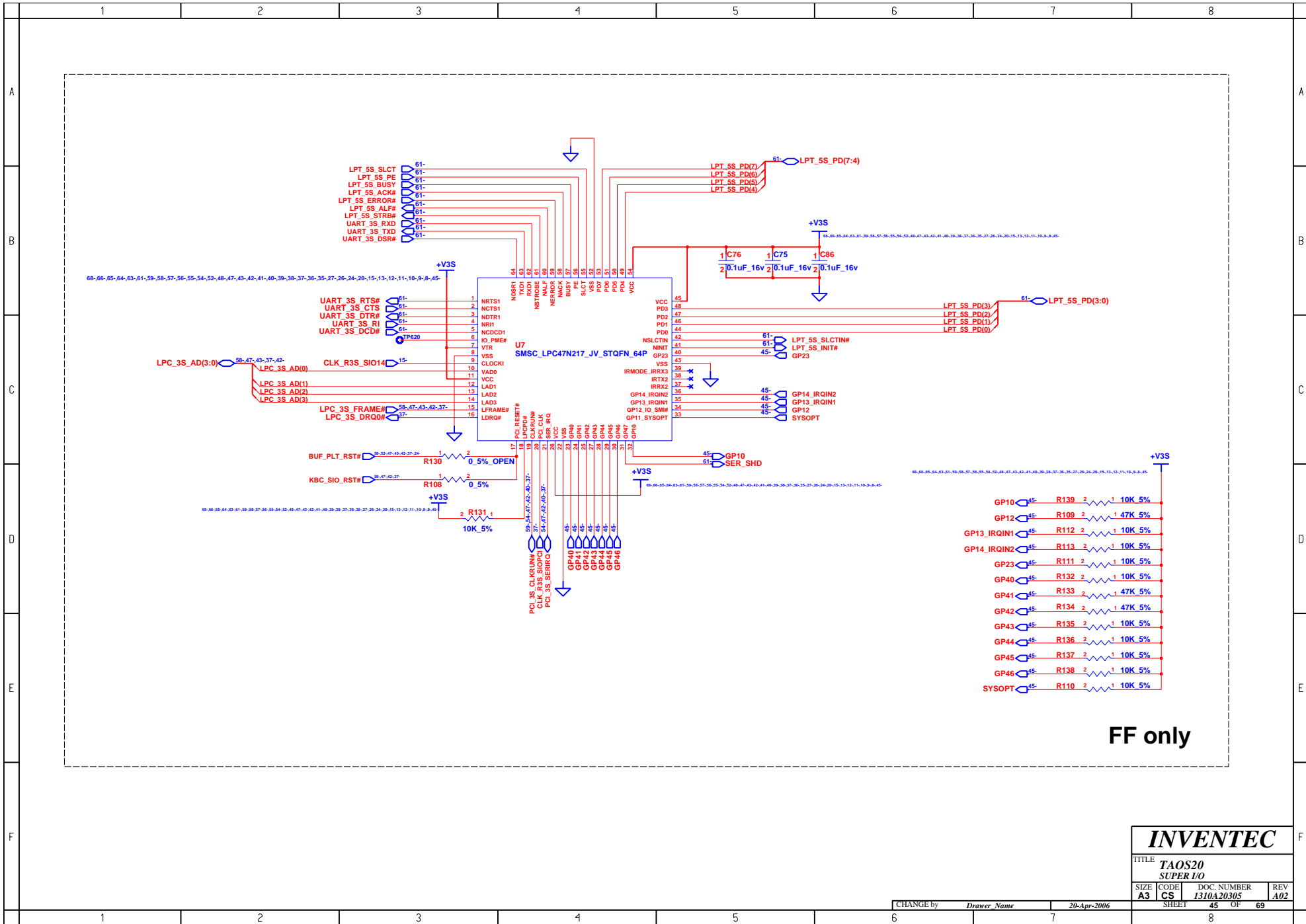

FF only

<b>INVENTEC</b>			
TITLE <b>TAOS20 SUPER I/O</b>			
SIZE <b>A3</b>	CODE <b>CS</b>	DOC. NUMBER <b>1310A20305</b>	REV <b>A02</b>
CHANGE by <i>Drawer Name</i>		20-Apr-2006	
SHEET 45		OF 69	

**BLANK**

**INVENTEC**

TITLE <i>TAOS20</i>			
Blank			
SIZE	CODE	DOC. NUMBER	REV
A3	CS	1310A20305	A02

CHANGE by *Drawer Name* 20-Apr-2006

SHEET 46 OF 69

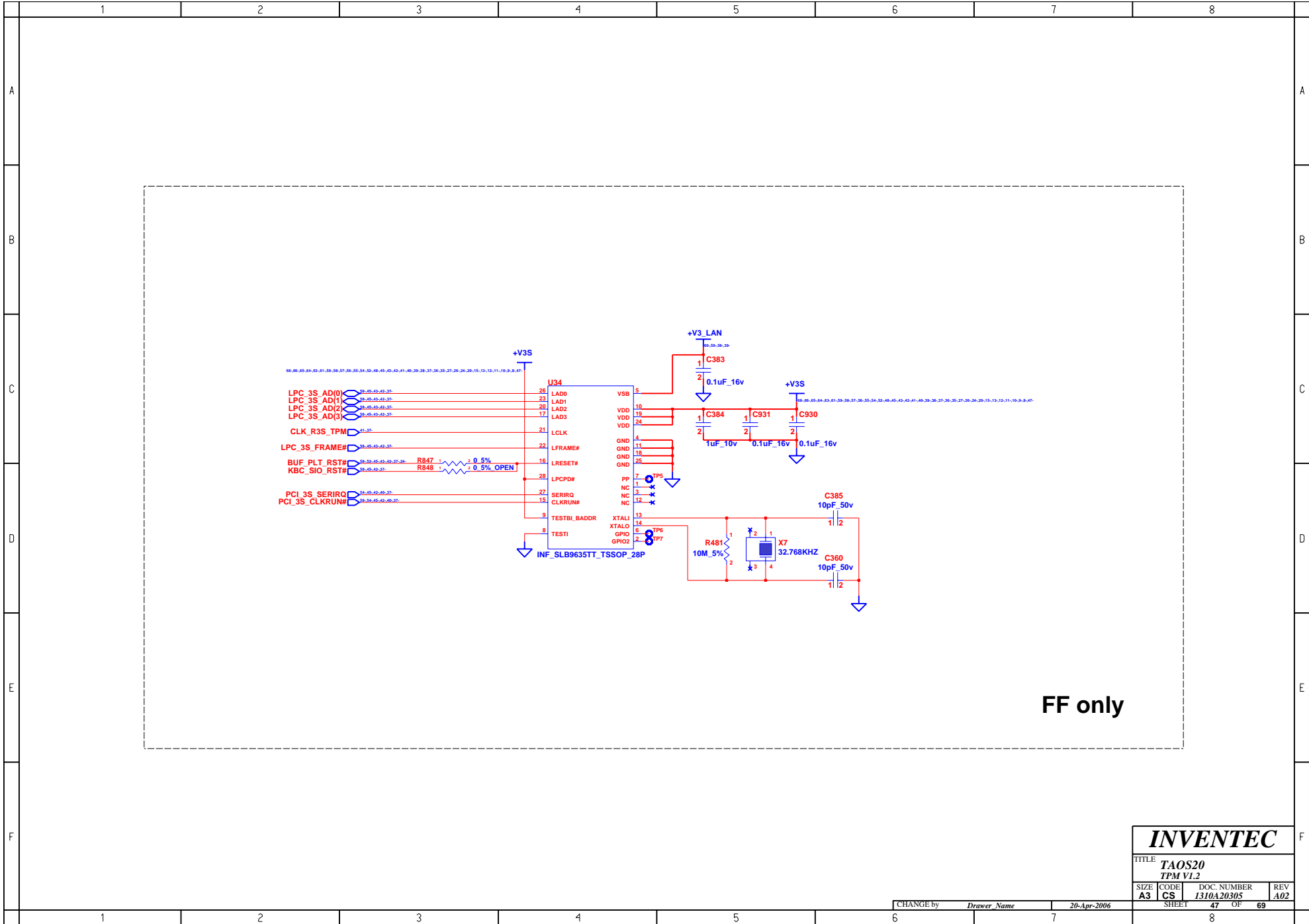

**INVENTEC**

TITLE  
**TAOS20  
 TPM V1.2**

SIZE <b>A3</b>	CODE <b>CS</b>	DOC. NUMBER <b>I310A20305</b>	REV <b>A02</b>
-------------------	-------------------	----------------------------------	-------------------

CHANGE by *Drawer Name* 20-Apr-2006

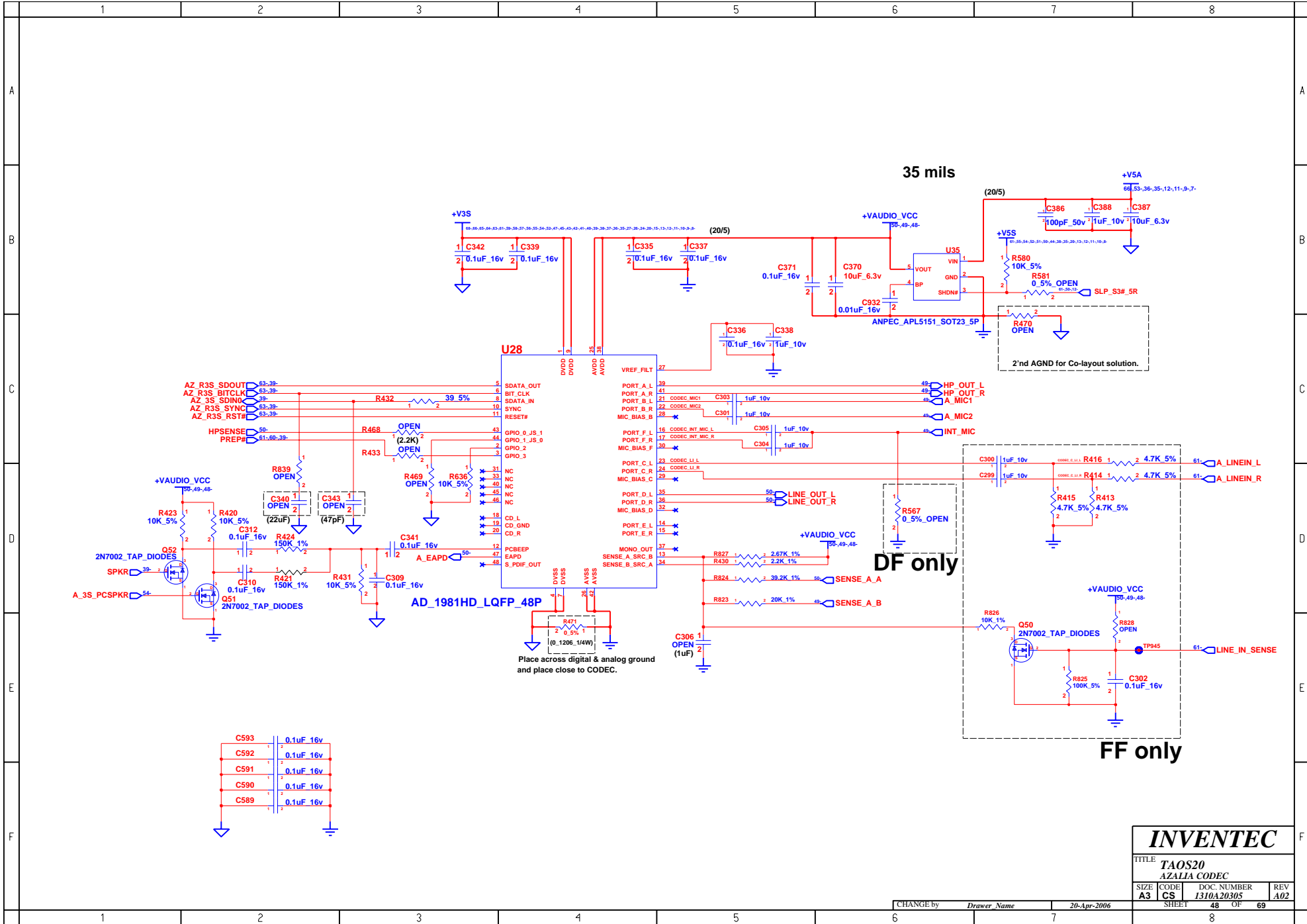

# INVENTEC

TITLE  
**TAOS20**  
**AZALIA CODEC**

SIZE	CODE	DOC. NUMBER	REV
A3	CS	I310A20305	A02

CHANGE by *Drawer Name* 20-Apr-2006 SHEET 48 OF 69



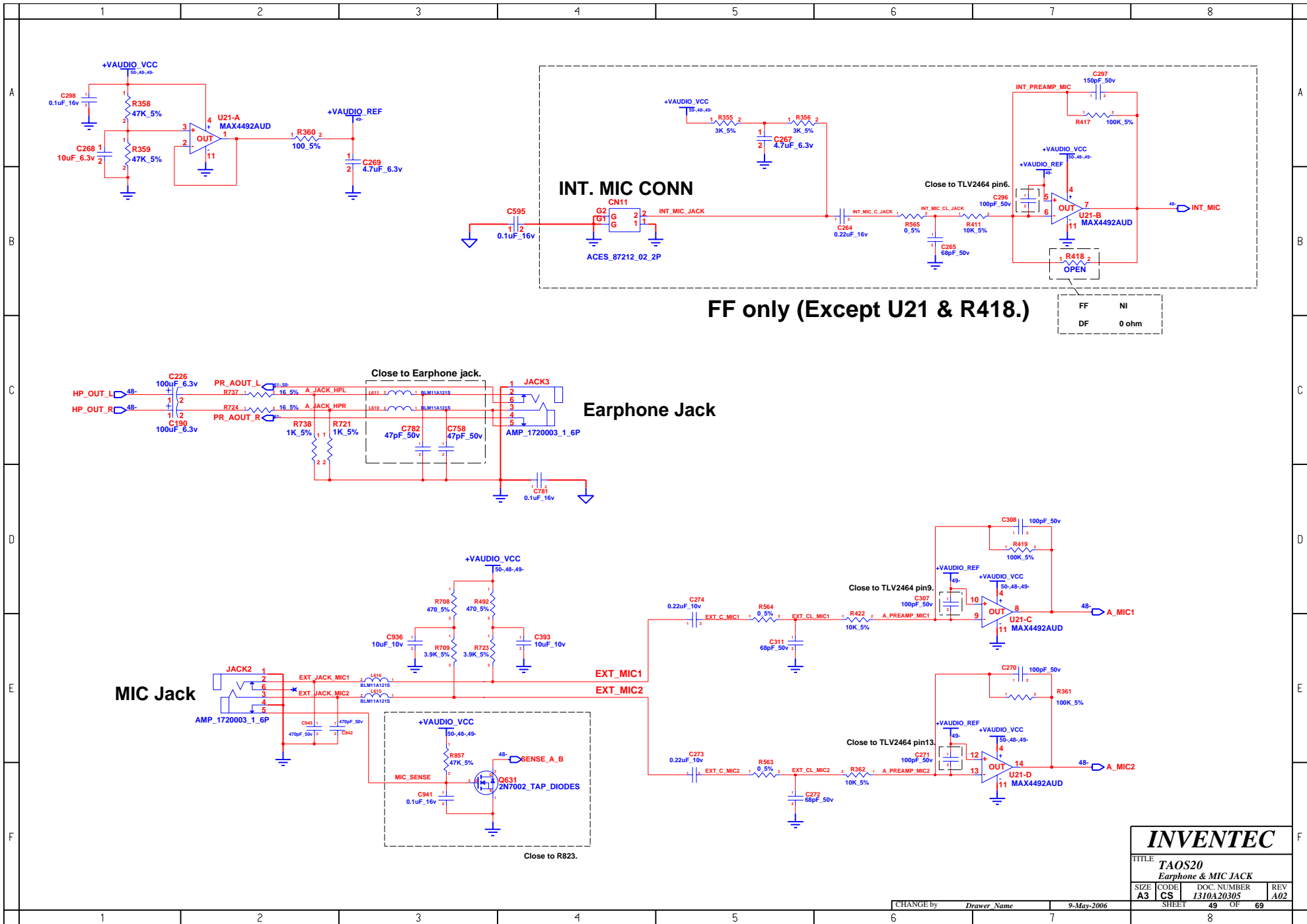

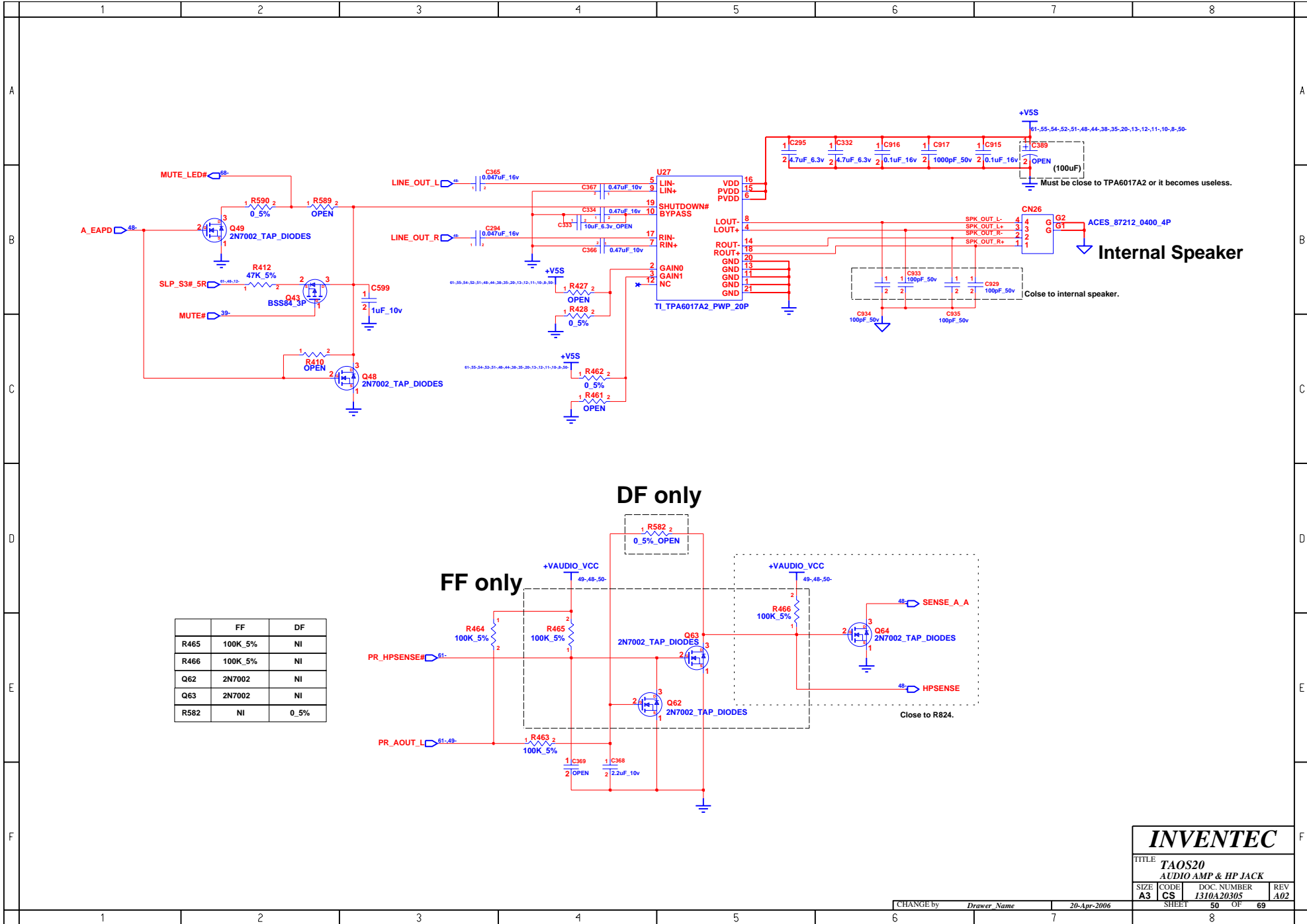

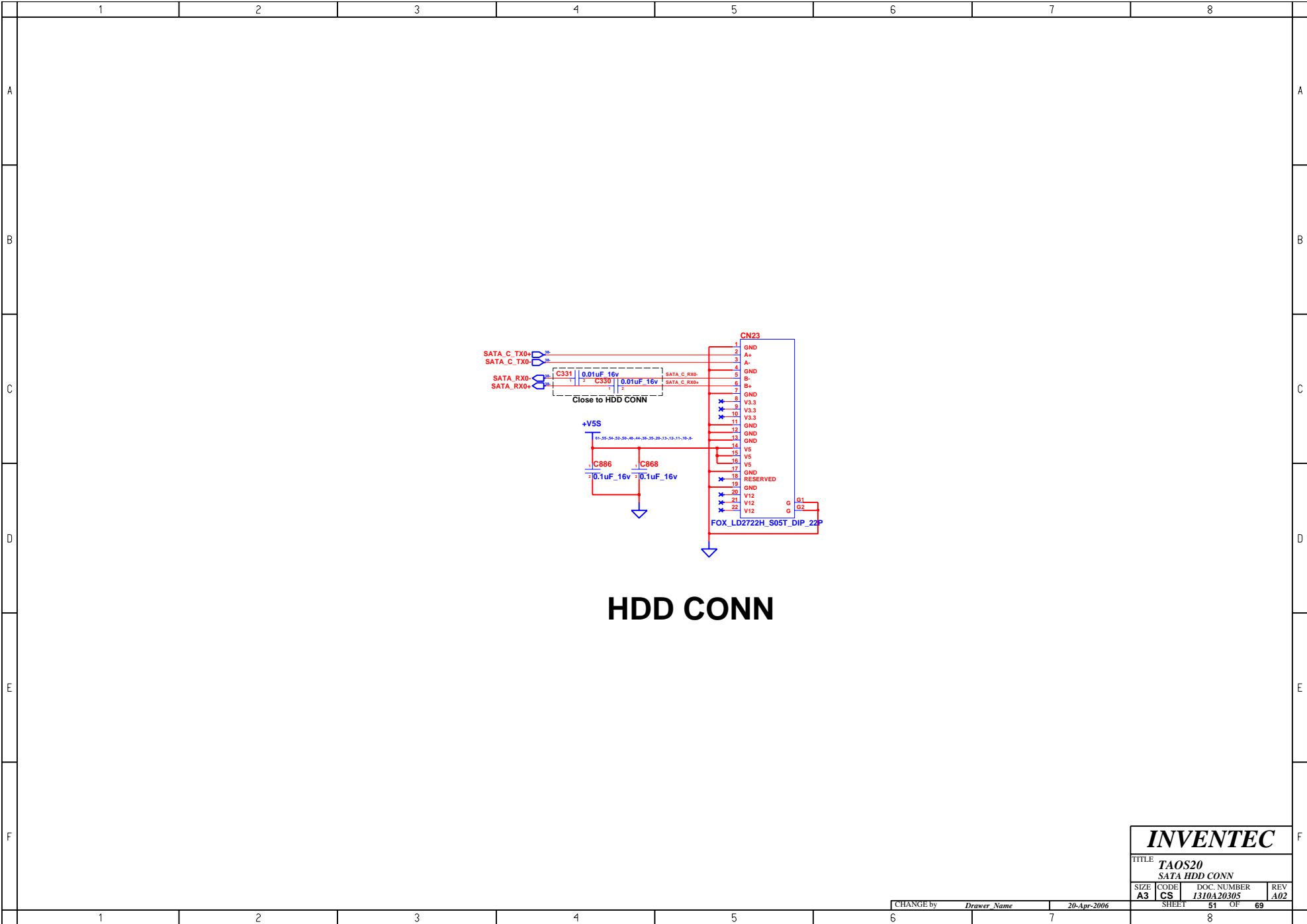

# HDD CONN

**INVENTEC**

TITLE			
TAOS20			
SATA HDD CONN			
SIZE	CODE	DOC. NUMBER	REV
A3	CS	1310A20305	A02

CHANGE by	Drawer Name	20-Apr-2006	SHEET	51	OF	69
-----------	-------------	-------------	-------	----	----	----

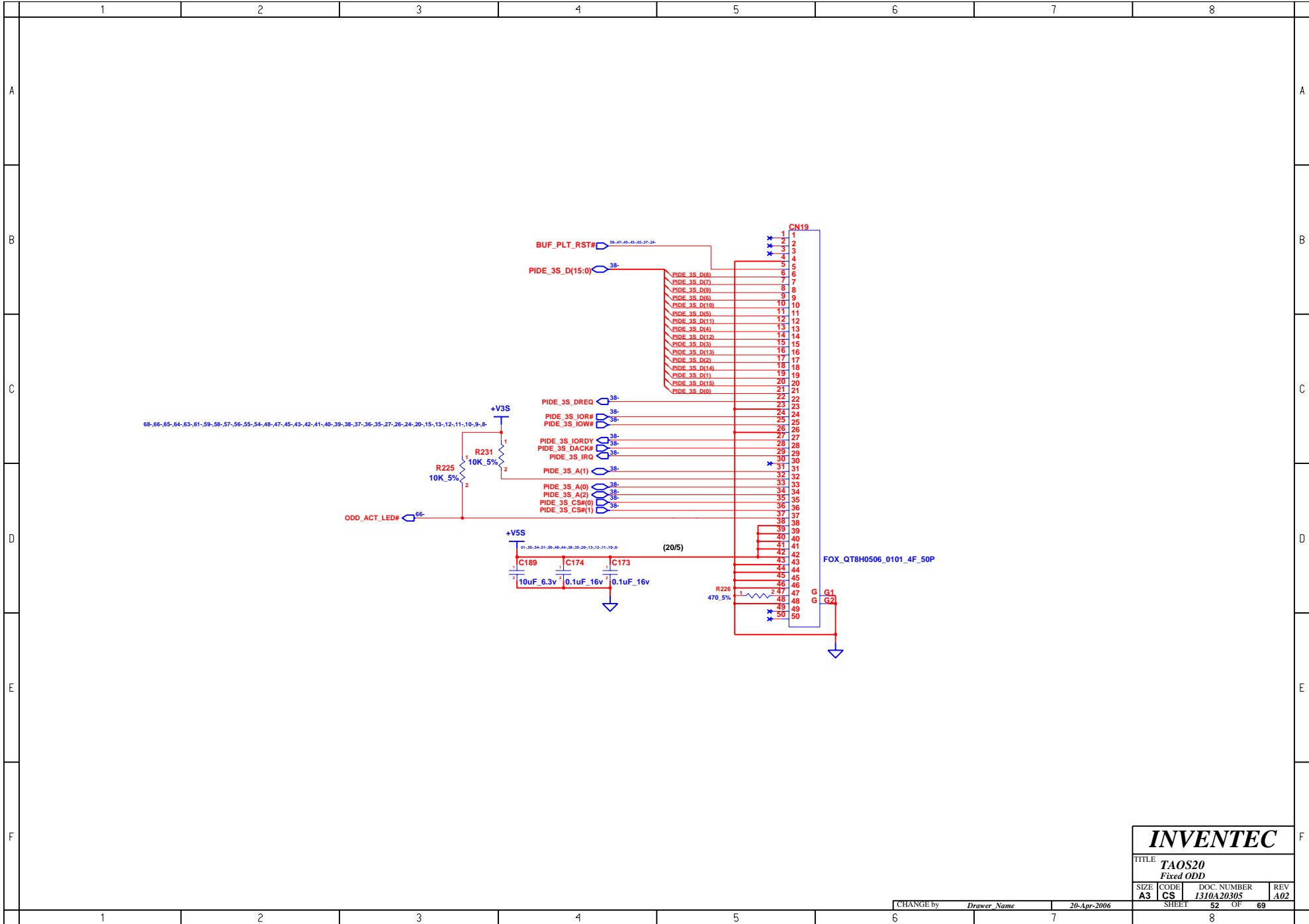

**INVENTEC**

TITLE TAOS20  
Fixed ODD

SIZE A3	CODE CS	DOC. NUMBER 1310A20305	REV A02
------------	------------	---------------------------	------------

CHANGE by *Drawer Name* 20-Apr-2006

SHEET 52 OF 69

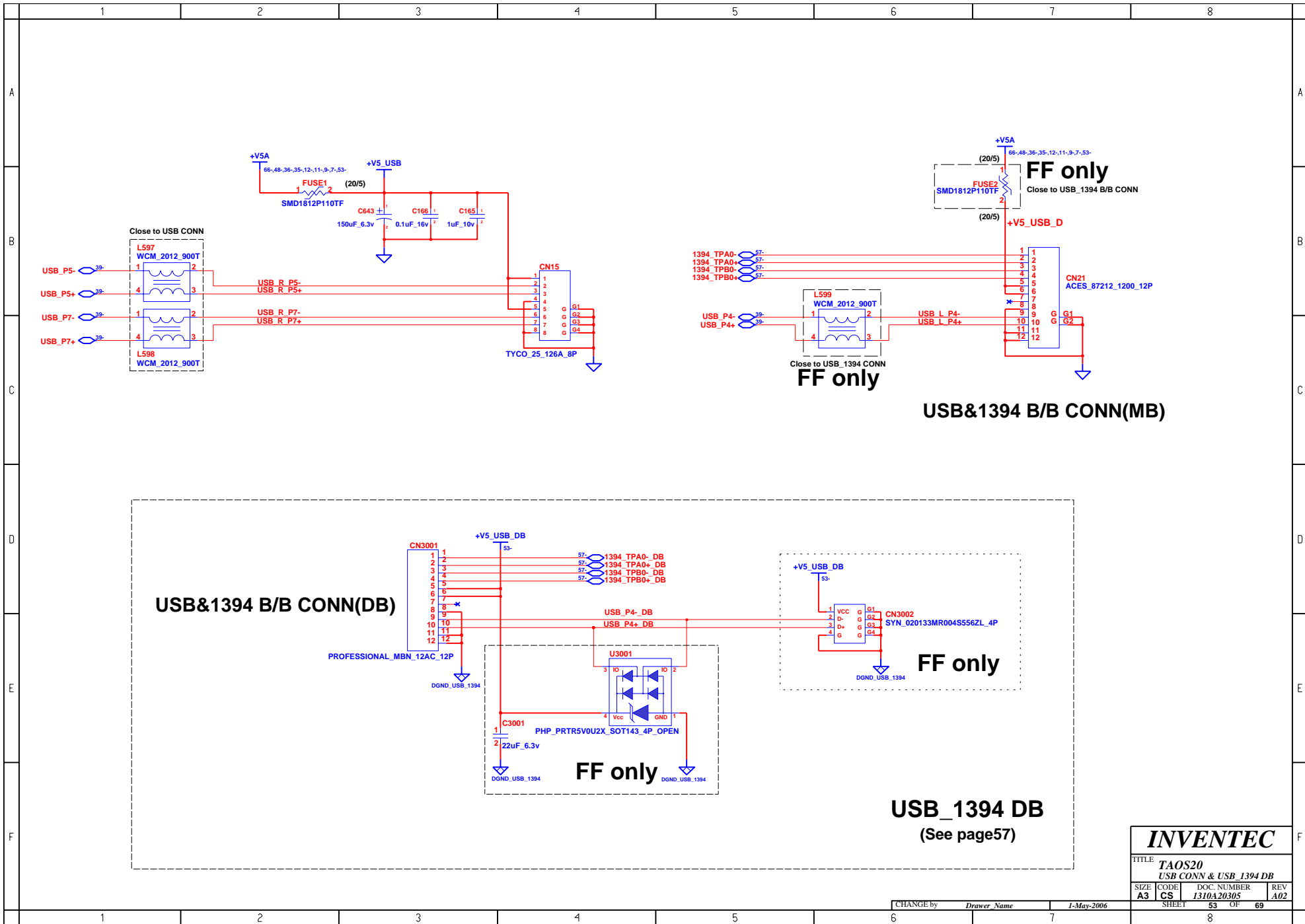

FF: TI\_PCI7612  
DF: TI\_PCI4512

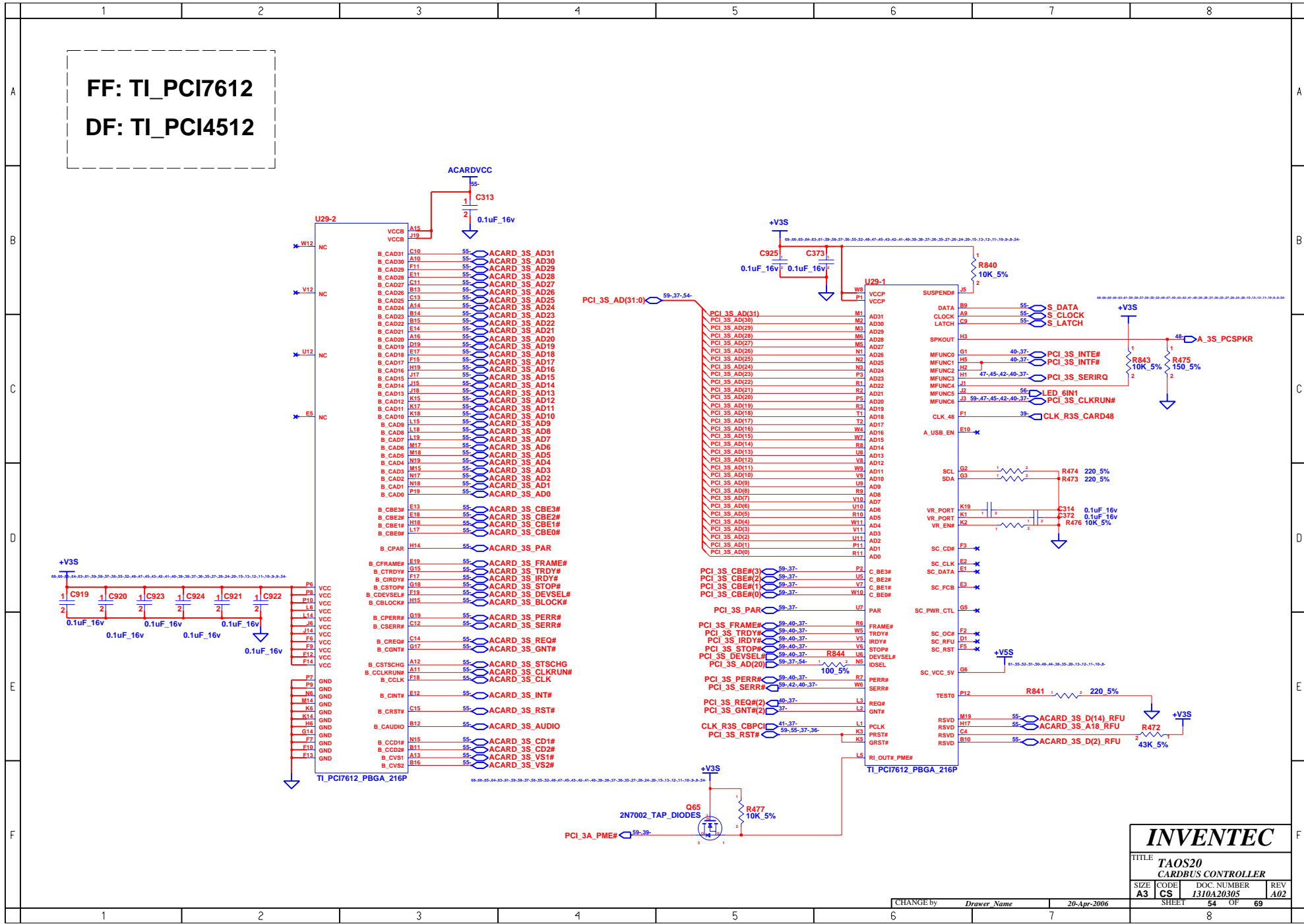

<b>INVENTEC</b>			
TITLE TAOS20 CARBUS CONTROLLER			
SIZE A3	CODE CS	DOC. NUMBER 1310A20305	REV A02

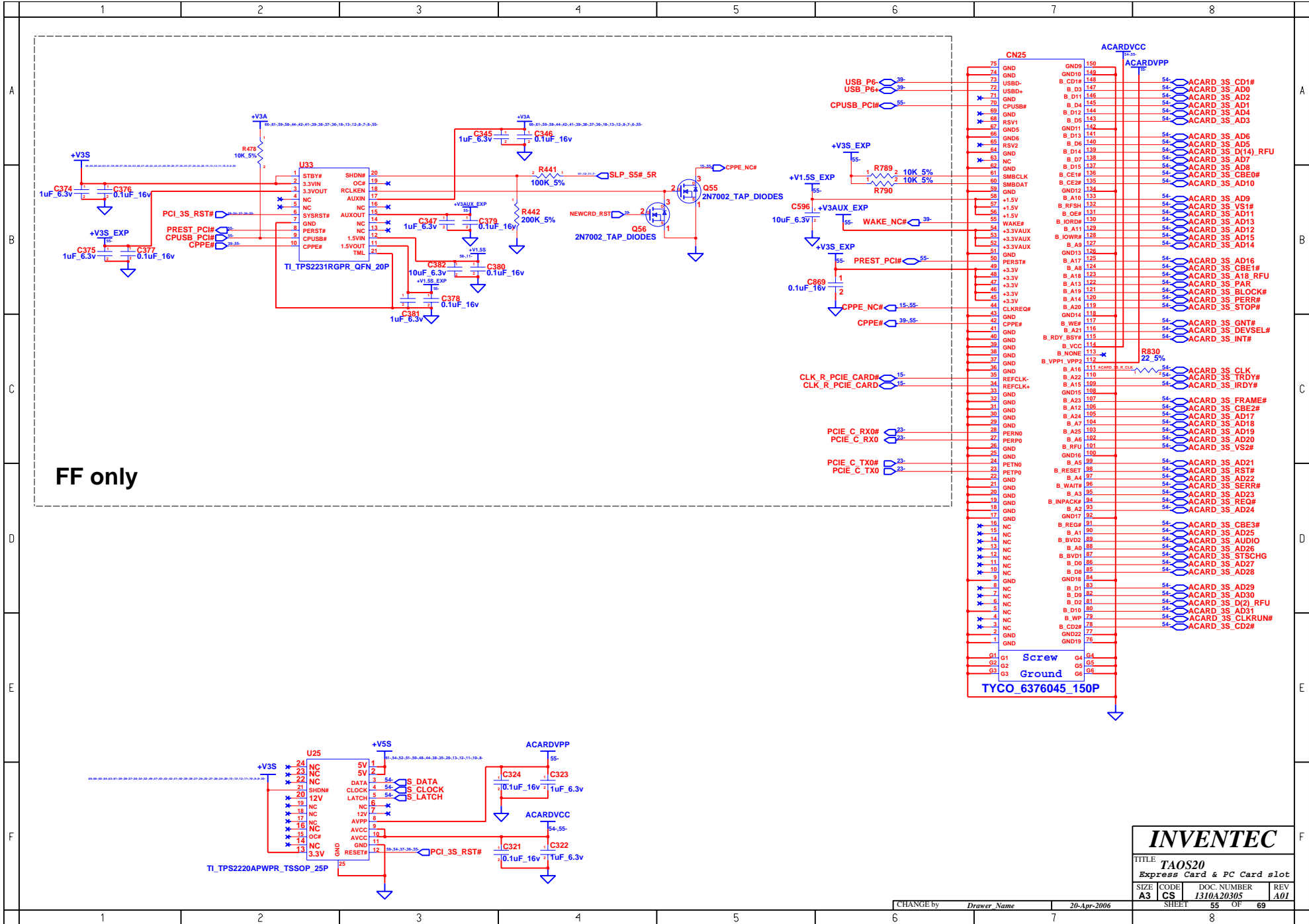

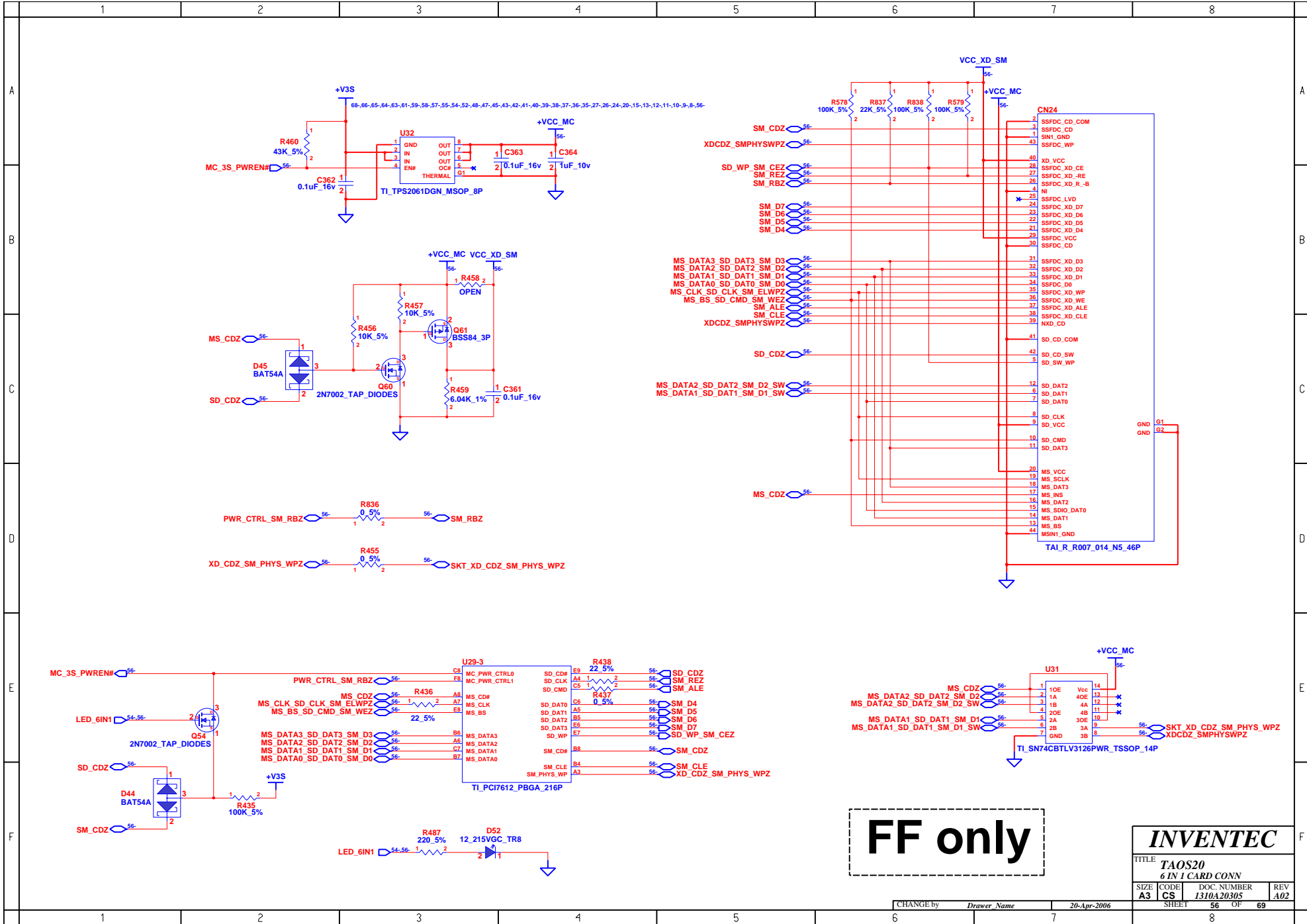



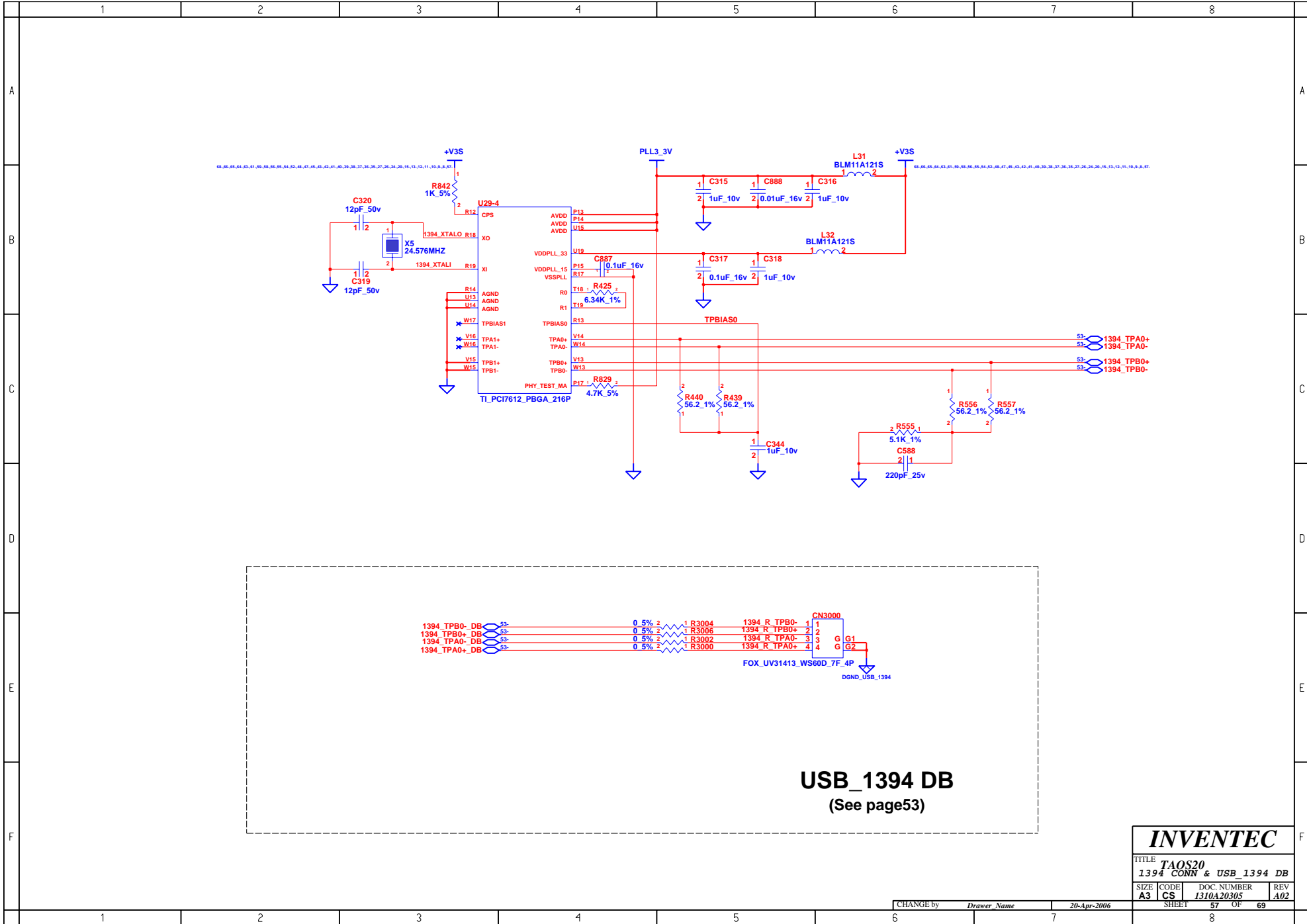

**USB\_1394 DB**  
(See page53)

**INVENTEC**

TITLE			
TAOS20			
1394 CONN & USB_1394 DB			
SIZE	CODE	DOC. NUMBER	REV
A3	CS	1310A20305	A02

CHANGE by	Drawer Name	20-Apr-2006	SHEET	57	OF	69
				8		

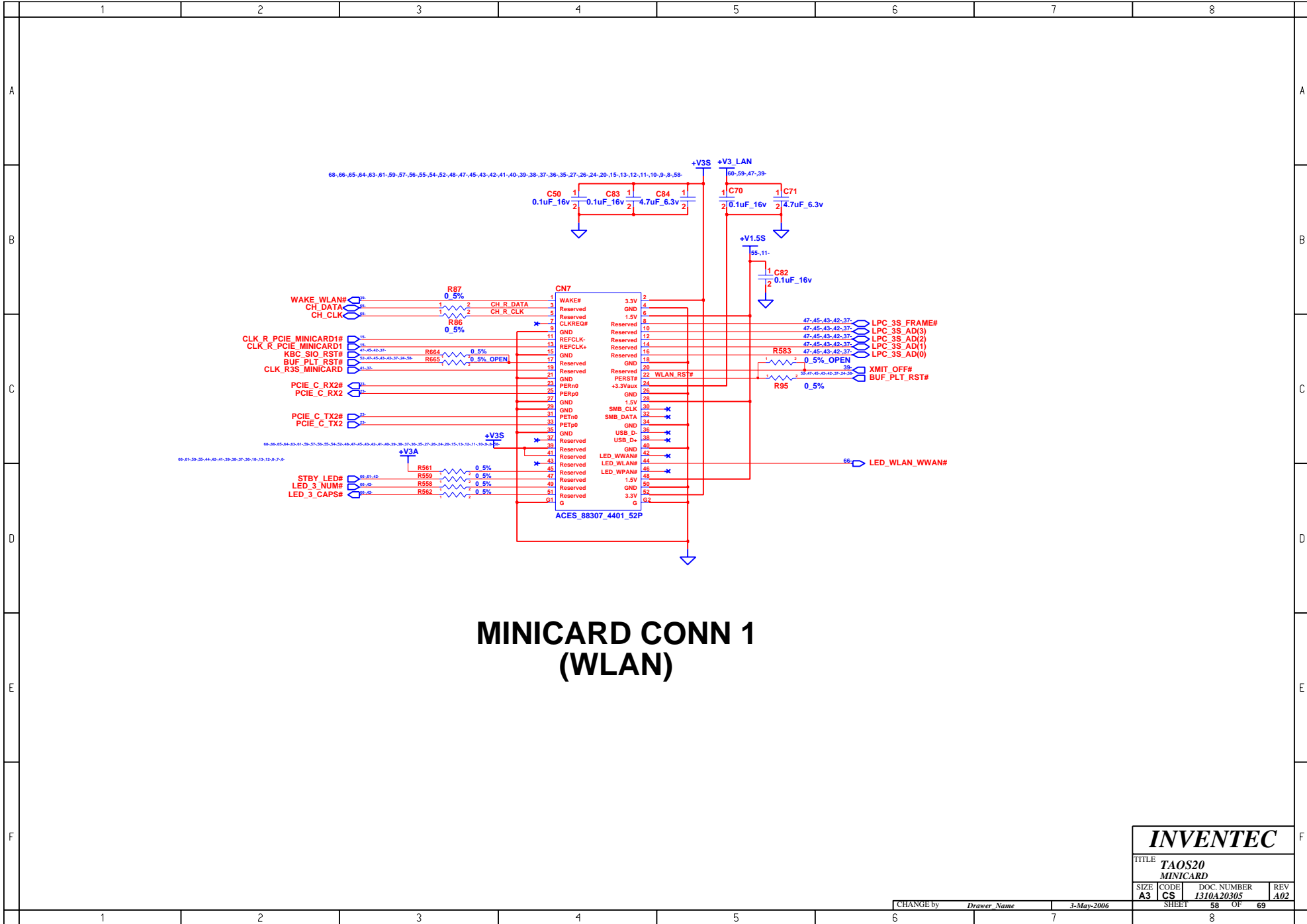

# MINICARD CONN 1 (WLAN)

**INVENTEC**

TITLE TAOS20  
MINICARD

SIZE A3	CODE CS	DOC. NUMBER I310A20305	REV A02
------------	------------	---------------------------	------------

REF (U23)	(FF) BCM5788	(DF) BCM4401
R344	NI	0.5%
R382	0.5%	NI
Q57	BCP69	NI
Q58	BCP69	NI
R443	1K_5%	NI
R444	1K_5%	NI
R445	1K_5%	NI
U26	AT24C64A	NI
U30	NI	AT93C46A
R832	NI	0.5%
C897	0.01uF_16V	NI
C894	0.01uF_16V	NI
C903	0.01uF_16V	NI

Lead Free Parts  
**FF:BCM5788MKFBG**  
**DF:BCM4401KFBG**

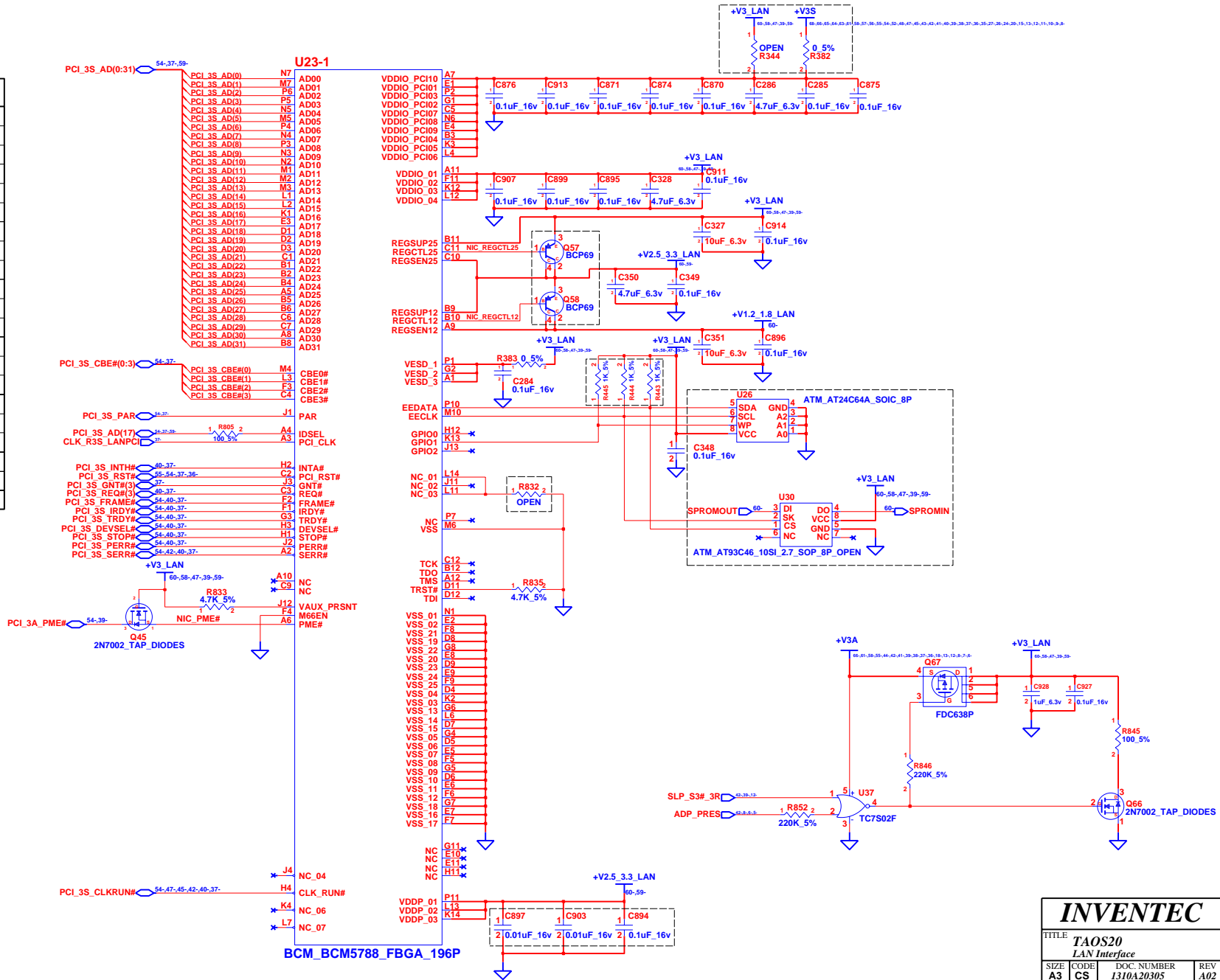

<b>INVENTEC</b>			
TITLE <b>TAOS20 LAN Interface</b>			
SIZE <b>A3</b>	CODE <b>CS</b>	DOC. NUMBER <b>I310A20305</b>	REV <b>A02</b>
CHANGE by <i>Drawer Name</i>		20-Apr-2006	
SHEET <b>59</b>		OF <b>69</b>	

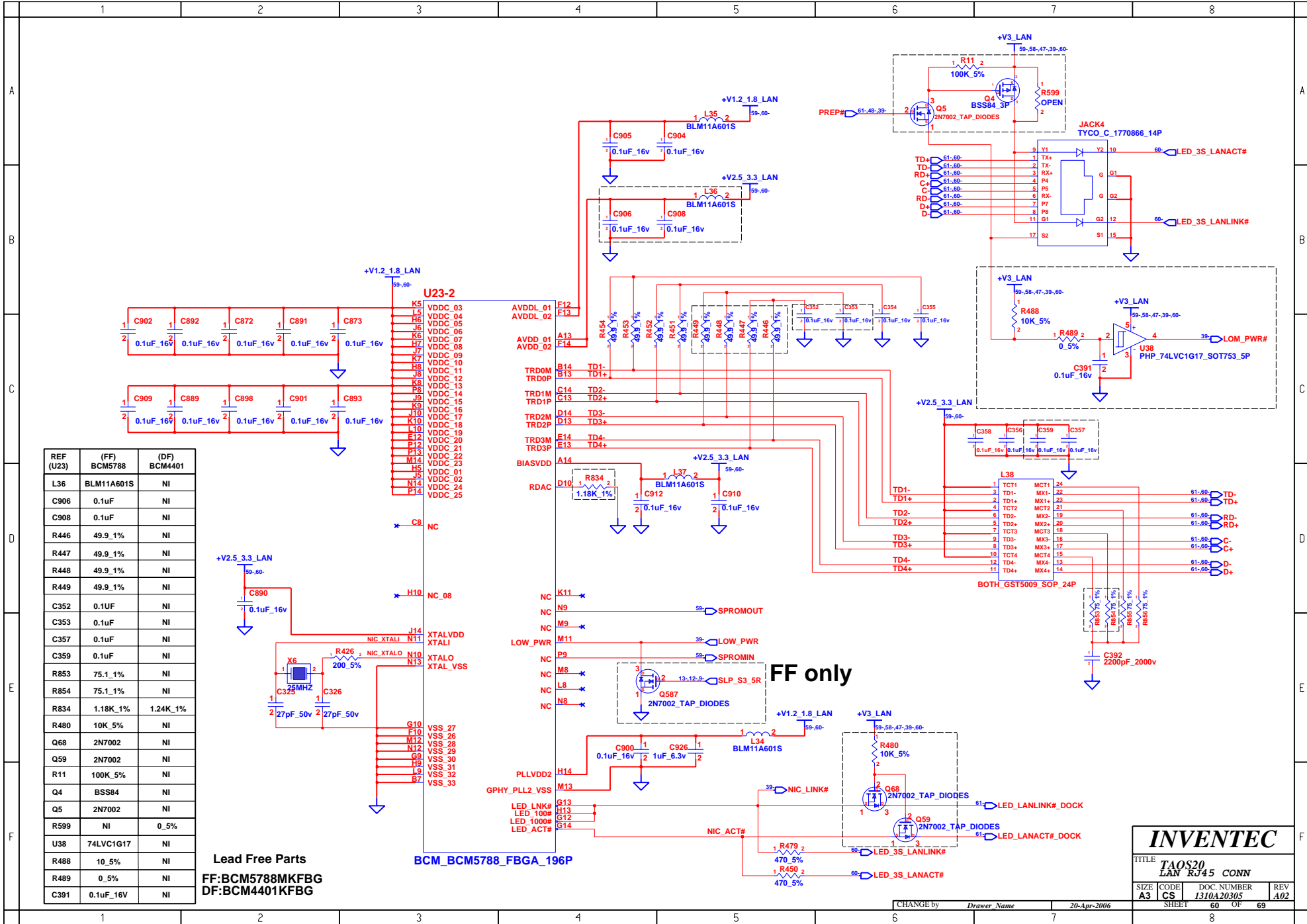

REF (U23)	(FF) BCM5788	(DF) BCM4401
L36	BLM11A601S	NI
C906	0.1uF	NI
C908	0.1uF	NI
R446	49.9_1%	NI
R447	49.9_1%	NI
R448	49.9_1%	NI
R449	49.9_1%	NI
C352	0.1uF	NI
C353	0.1uF	NI
C357	0.1uF	NI
C359	0.1uF	NI
R853	75.1_1%	NI
R854	75.1_1%	NI
R834	1.18K_1%	1.24K_1%
R480	10K_5%	NI
Q68	2N7002	NI
Q59	2N7002	NI
R11	100K_5%	NI
Q4	BSS84	NI
Q5	2N7002	NI
R599	NI	0.5%
U38	74LVC1G17	NI
R488	10_5%	NI
R489	0.5%	NI
C391	0.1uF_16V	NI

Lead Free Parts  
 FF:BCM5788MKFBG  
 DF:BCM4401KFBG

BCM\_BCM5788\_FPGA\_196P

FF only

**INVENTEC**

TITLE TAOS20 LAN RJ45 CONN

SIZE	CODE	DOC. NUMBER	REV
A3	CS	I310A20305	A02

CHANGE by *Drawer Name* 20-Apr-2006 SHEET 60 OF 69

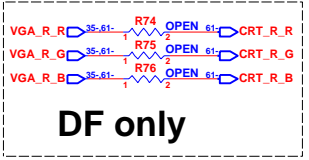
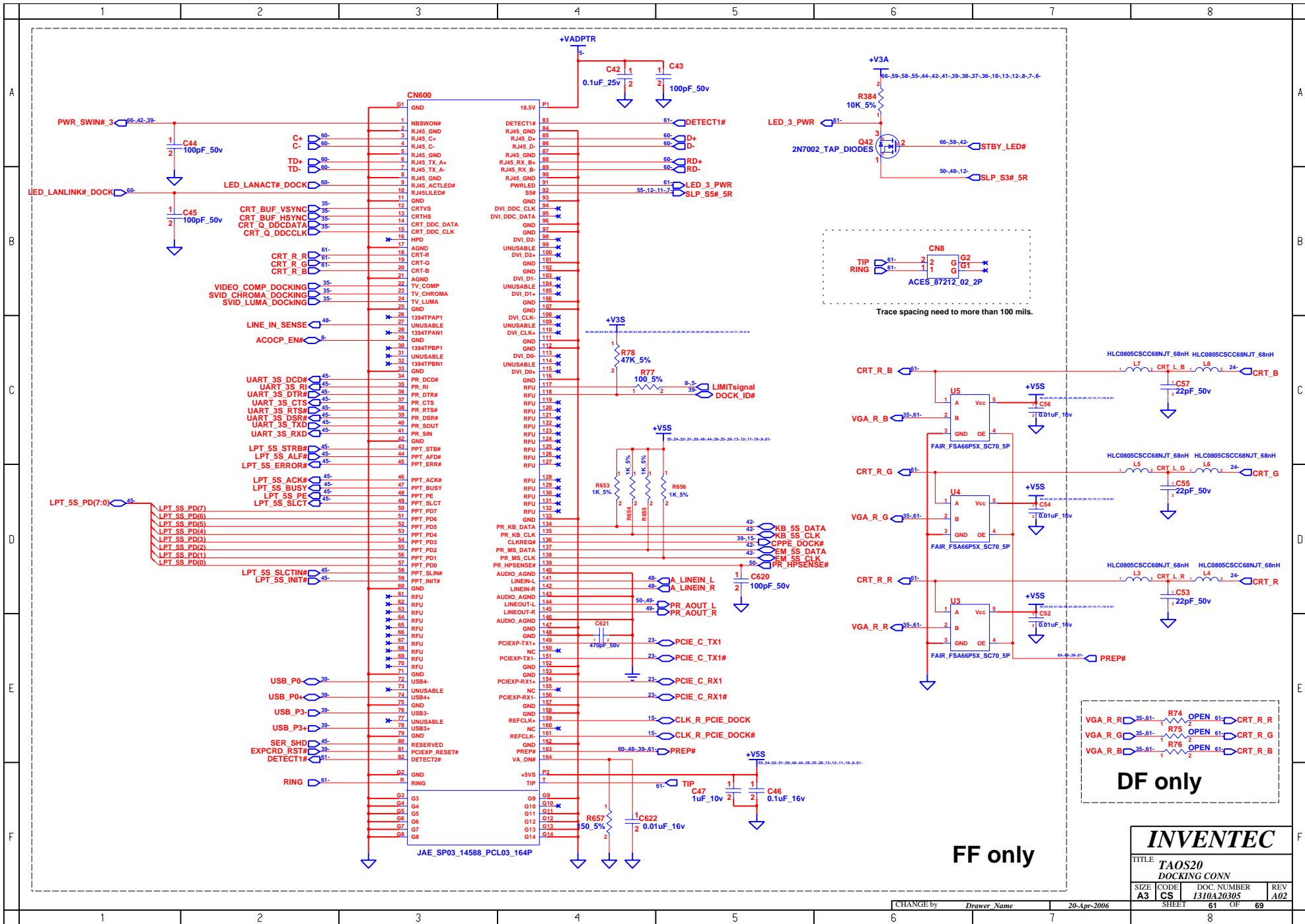

**FF only**

<b>INVENTEC</b>			
TITLE TAOS20 DOCKING CONN			
SIZE A3	CODE CS	DOC. NUMBER 1310A20305	REV A02
SHEET 61		OF 69	

CHANGE by *Drawer Name* 20-Apr-2006

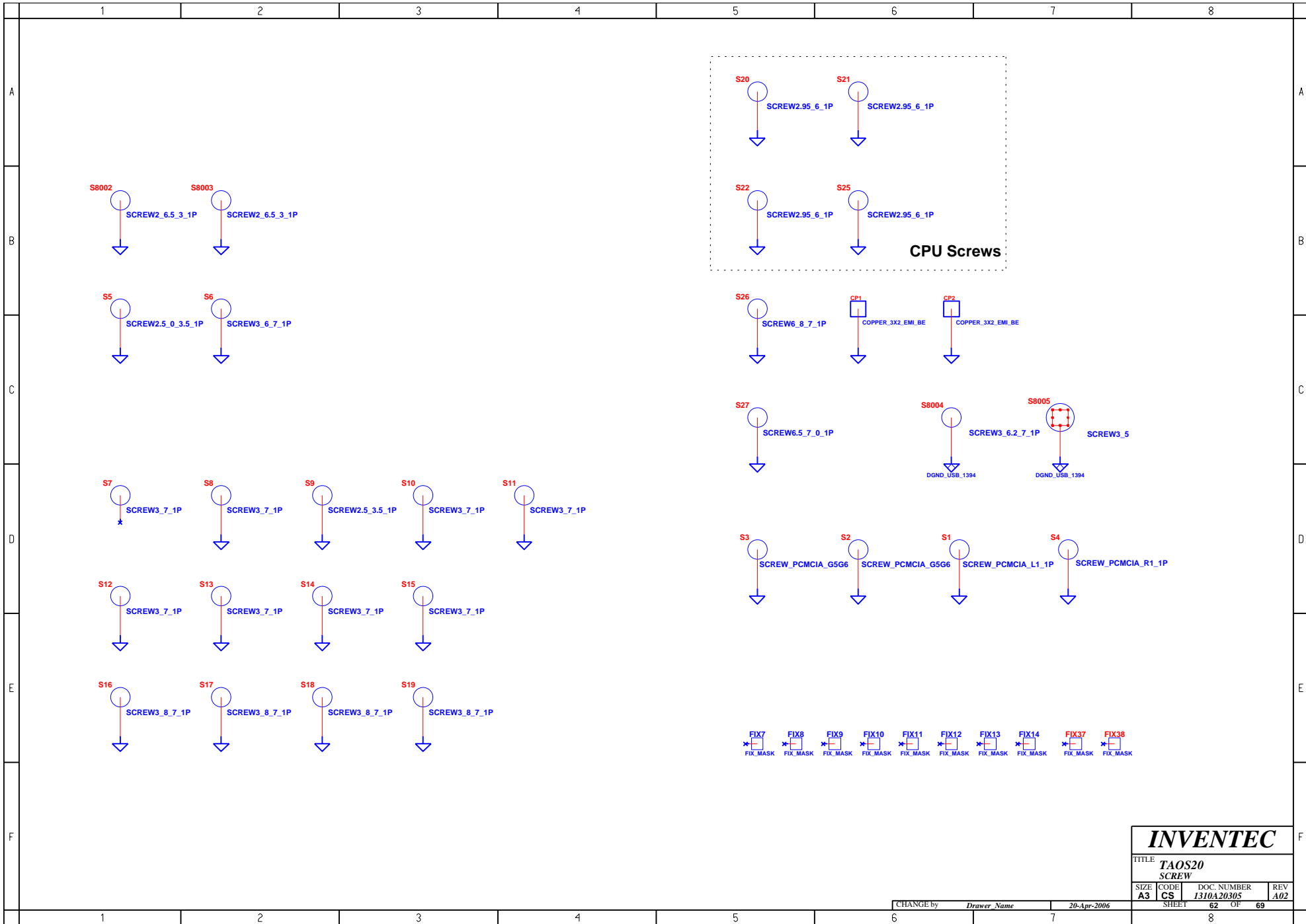

**INVENTEC**

TITLE  
**TAOS20**  
**SCREW**

SIZE <b>A3</b>	CODE <b>CS</b>	DOC. NUMBER <b>1310A20305</b>	REV <b>A02</b>
-------------------	-------------------	----------------------------------	-------------------

CHANGE by *Drawer Name* 20-Apr-2006 SHEET 62 OF 69

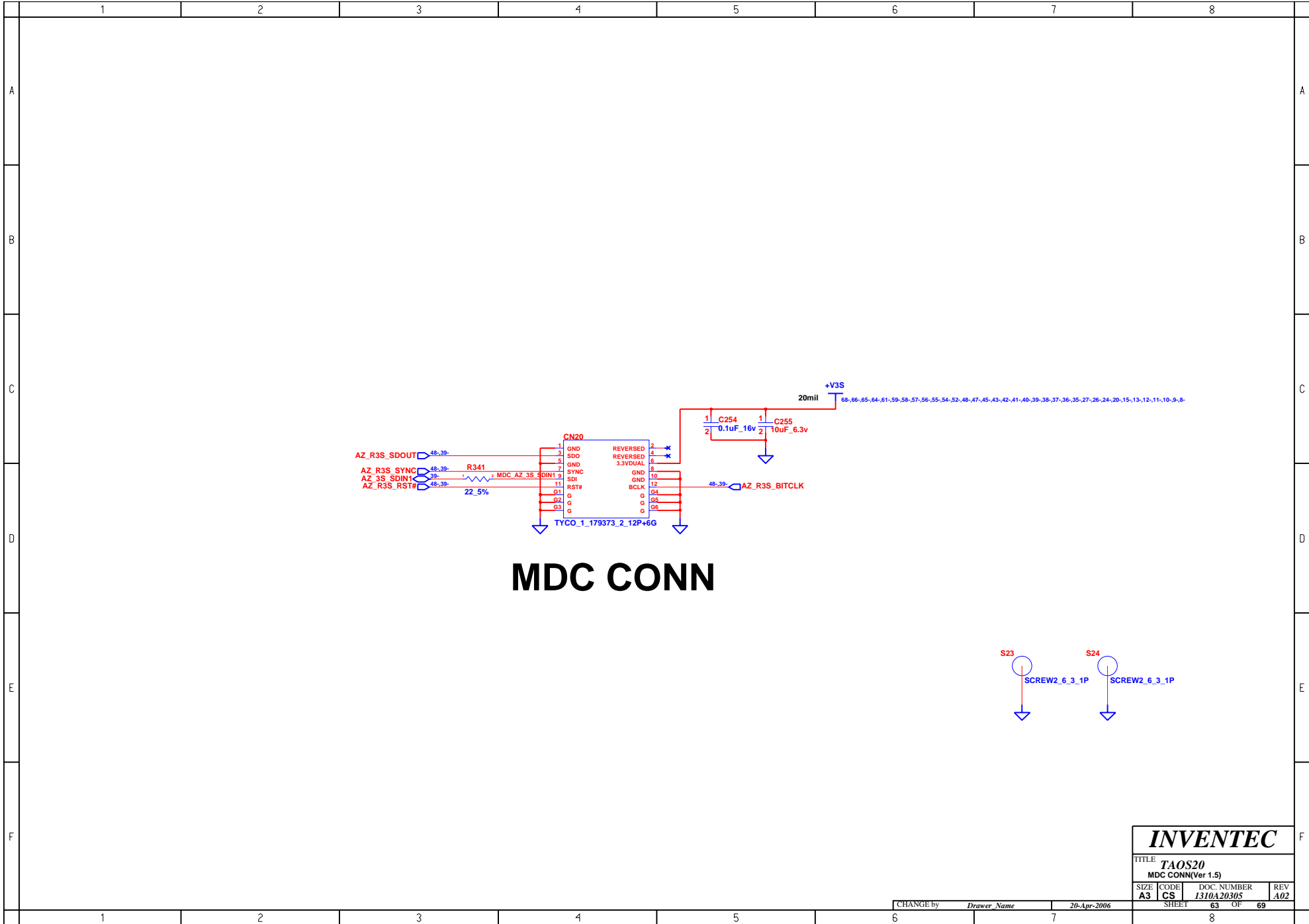

# MDC CONN

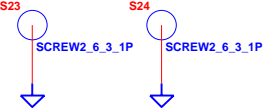

**INVENTEC**

TITLE TAOS20			
MDC CONN(Ver 1.5)			
SIZE A3	CODE CS	DOC. NUMBER 1310A20305	REV A02

CHANGE by *Drawer Name* 20-Apr-2006

SHEET 63 OF 69

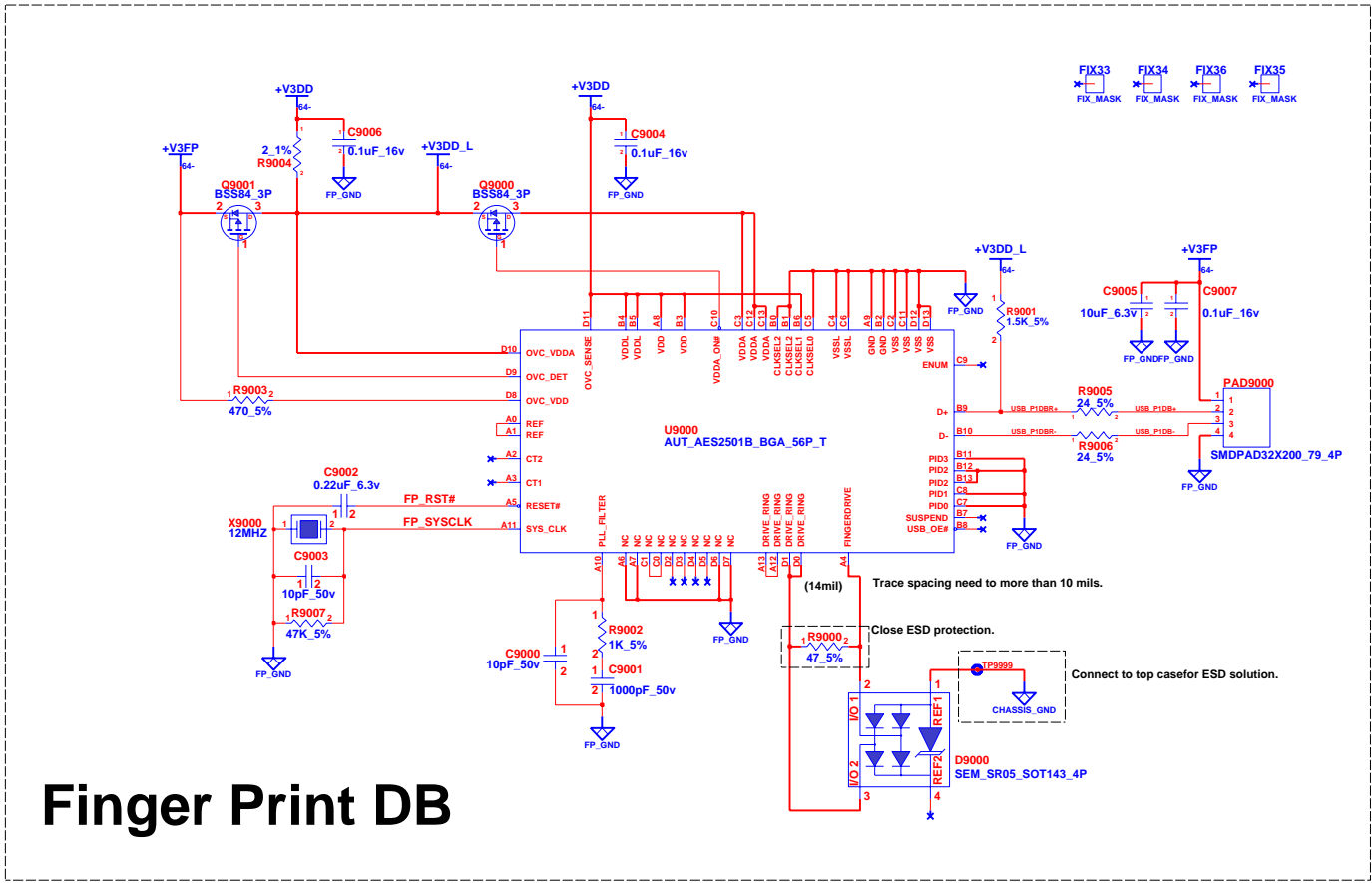

# Finger Print DB

**FF only**

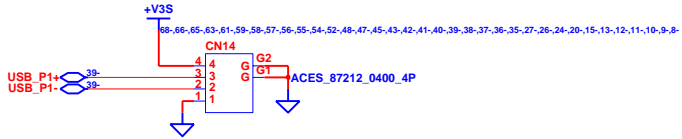

<b>INVENTEC</b>			
TITLE <b>TAOS20</b> Fingerprint			
SIZE <b>A3</b>	CODE <b>CS</b>	DOC. NUMBER <b>1310A20522</b>	REV <b>A01</b>
CHANGE by Drawer Name		20-Apr-2006	
SHEET 64		OF 69	



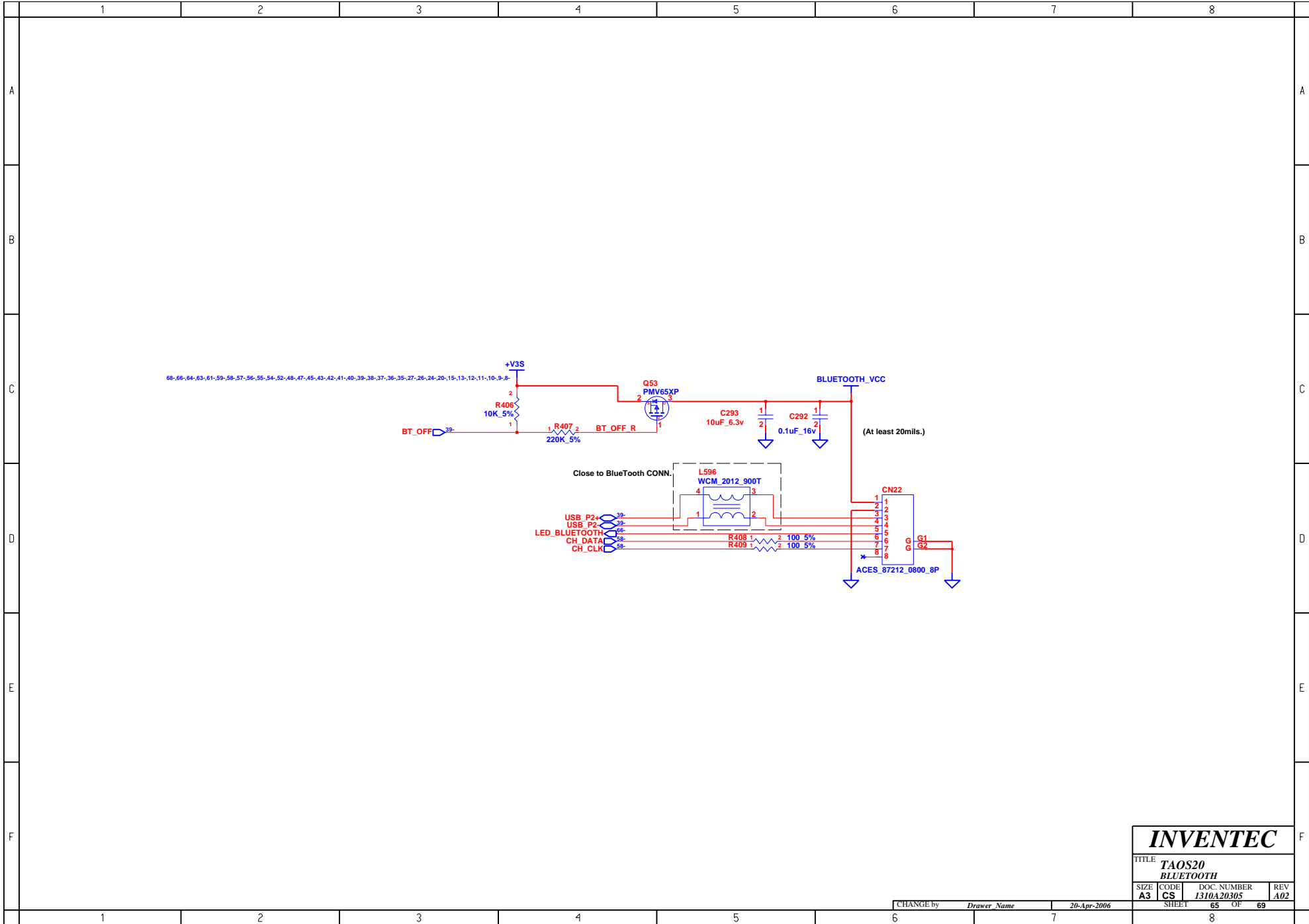

**INVENTEC**

TITLE  
**TAOS20  
 BLUETOOTH**

SIZE <b>A3</b>	CODE <b>CS</b>	DOC. NUMBER <b>1310A20305</b>	REV <b>A02</b>
-------------------	-------------------	----------------------------------	-------------------

CHANGE by *Drawer Name* 20-Apr-2006

SHEET 65 OF 69

### LID SW

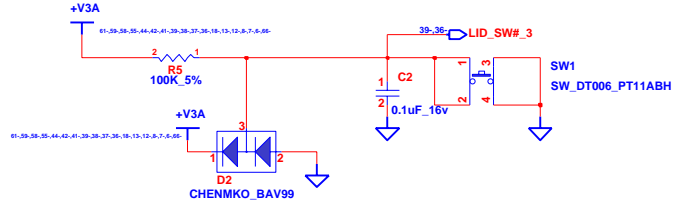

### Power SW

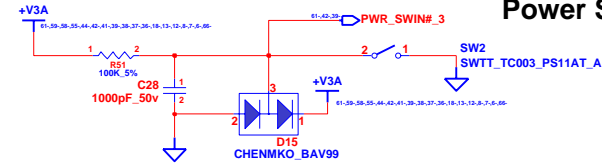

### DF only

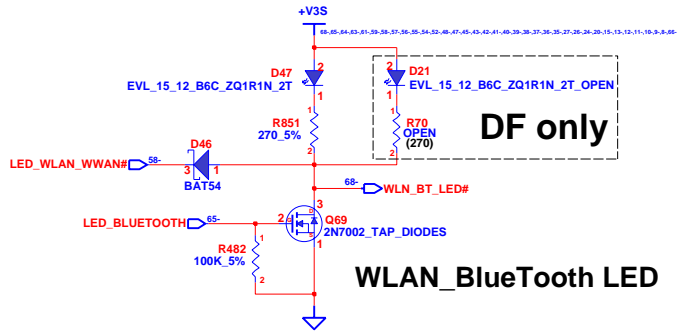

### WLAN\_BlueTooth LED

### Power / Standby LED

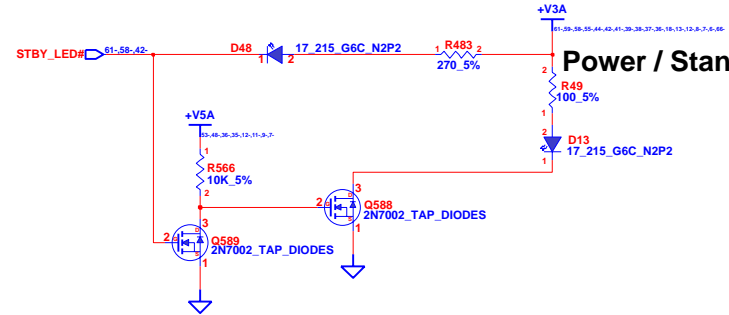

### WLAN\_BlueTooth SW

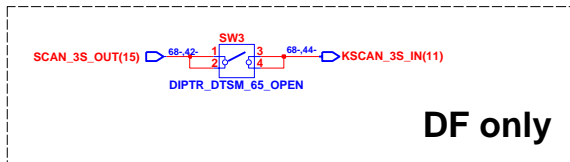

### Battery-Charge LED

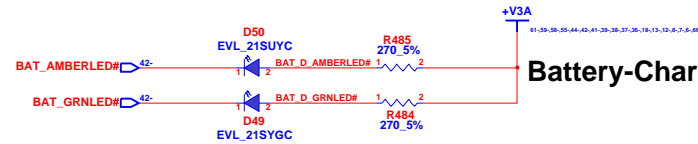

### HDD & ODD LED

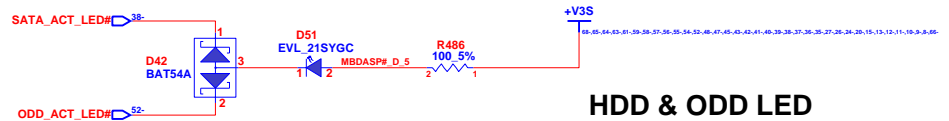

### CAP LOCK LED

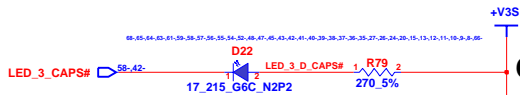

### NUM LOCK LED

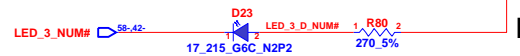

### Accelerometer LED (NI)

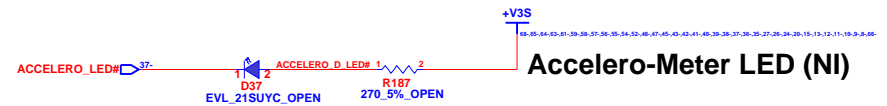

## INVENTEC

TITLE TAOS20 LID/POWER SWITCH & LED			
SIZE A3	CODE CS	DOC. NUMBER I310A20305	REV A02

**BLANK**

**INVENTEC**

TITLE			
TAOS20			
BLANK			
SIZE	CODE	DOC. NUMBER	REV
A3	CS	1310A20305	A02
SHEET		67	OF 69

CHANGE by *Drawer Name* 20-Apr-2006

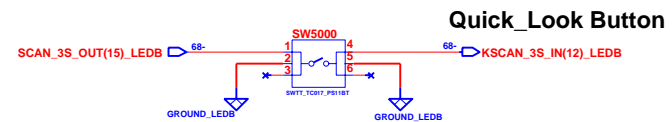
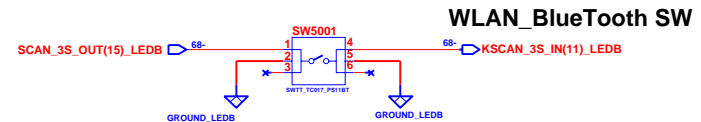
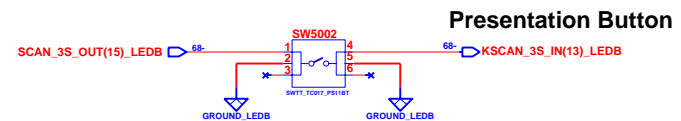
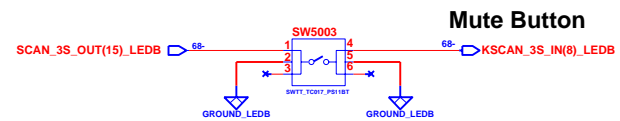
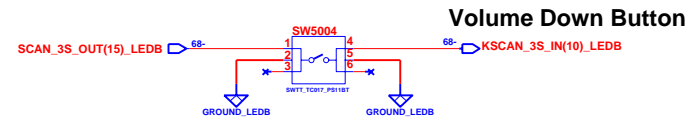
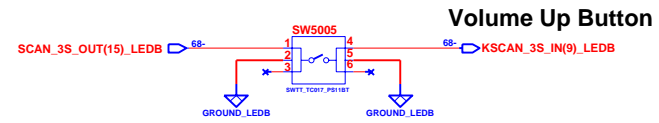
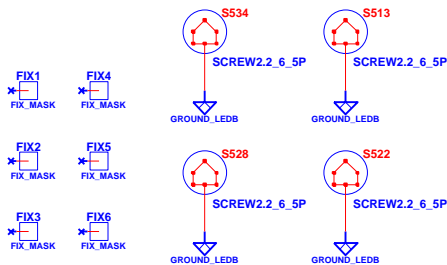
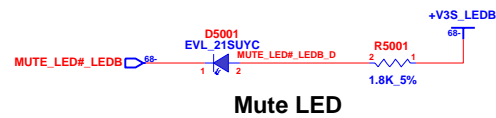
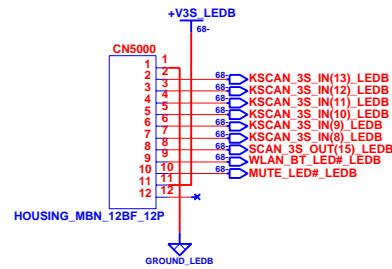
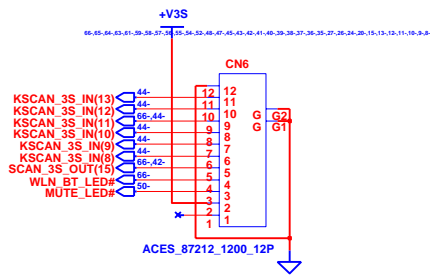

# Switch Button DB

**FF only**

**INVENTEC**

TITLE			
TAOS20			
LED/SWITCH BOARD			
SIZE	CODE	DOC. NUMBER	REV
A3	CS	1310A20305	A02

CHANGE by	Drawer Name	3-May-2006	SHEET	68	OF	69
-----------	-------------	------------	-------	----	----	----

### 1394\_USB cable

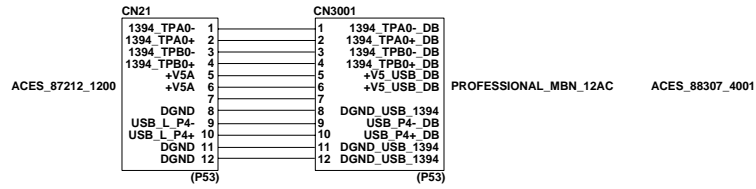

### LCM cable

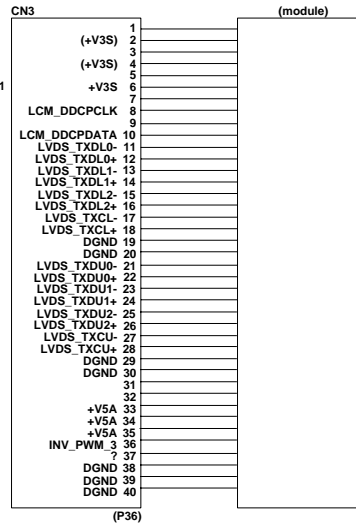

### TouchPad cable

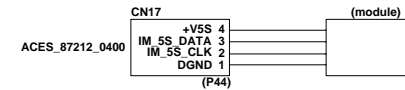

### SW/B cable

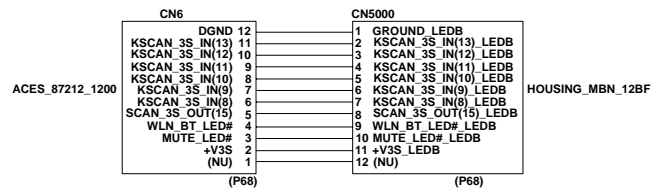

### INT\_Speaker cable

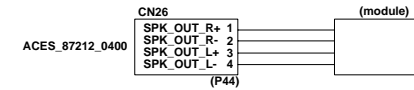

### INT\_MIC cable

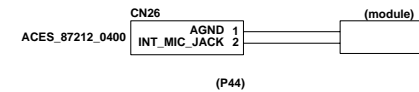

### Keyboard cable

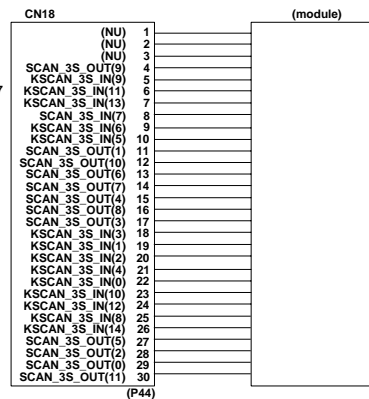

### Bluetooth cable

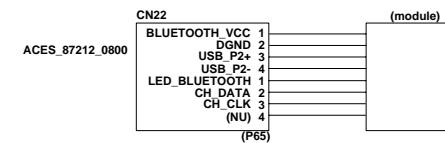

### Fingerprint cable

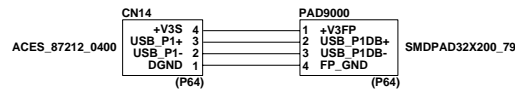

### MODEM cable

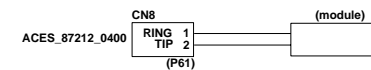

**INVENTEC**

TITLE TAOS20			
Cable Relation			
SIZE A3	CODE CS	DOC. NUMBER 1310A20305	REV A02