

μA725

INSTRUMENTATION OPERATIONAL AMPLIFIER

FAIRCHILD LINEAR INTEGRATED CIRCUITS

GENERAL DESCRIPTION – The μA725 is a monolithic Instrumentation Operational Amplifier constructed using the Fairchild Planar* epitaxial process. It is intended for precise, low level signal amplification applications where low noise, low drift and accurate closed loop gain are required. The offset null capability, low power consumption, very high voltage gain as well as wide power supply voltage range provide superior performance for a wide range of instrumentation applications. The μA725 is pin compatible with the popular μA741 operational amplifier.

- **LOW INPUT NOISE CURRENT** – $0.15 \text{ pA}/\sqrt{\text{Hz}}$
- **HIGH OPEN LOOP GAIN** – 3,000,000
- **LOW INPUT OFFSET CURRENT** – 2 nA
- **LOW INPUT VOLTAGE DRIFT** – $0.6 \text{ } \mu\text{V}/^\circ\text{C}$
- **HIGH COMMON MODE REJECTION** – 120 dB
- **HIGH INPUT VOLTAGE RANGE** – $\pm 14 \text{ V}$
- **WIDE POWER SUPPLY RANGE** – $\pm 3 \text{ V TO } \pm 22 \text{ V}$
- **OFFSET NULL CAPABILITY**

ABSOLUTE MAXIMUM RATINGS

Supply Voltage	±22
Internal Power Dissipation (Note 1)	
Metal Can	500 mW
Differential Input Voltage	±5 V
Input Voltage (Note 2)	±22 V
Voltage Between Offset Null and V ⁺	±0.5 V
Storage Temperature Range	
Metal Can	–65°C to +150°C
Operating Temperature Range	
Military (μA725A, μA725)	–55°C to +125°C
Commercial (μA725E, μA725C)	0°C to +70°C
Lead Temperature	
Metal Can (Soldering, 60 Seconds)	300°C

CONNECTION DIAGRAM

8-LEAD METAL CAN
(TOP VIEW)

PACKAGE OUTLINE 5S
PACKAGE CODE H

ORDER INFORMATION

TYPE	PART NO.
μA725A	μA725AHM
μA725	μA725HM
μA725C	μA725HC
μA725E	μA725EHC

12

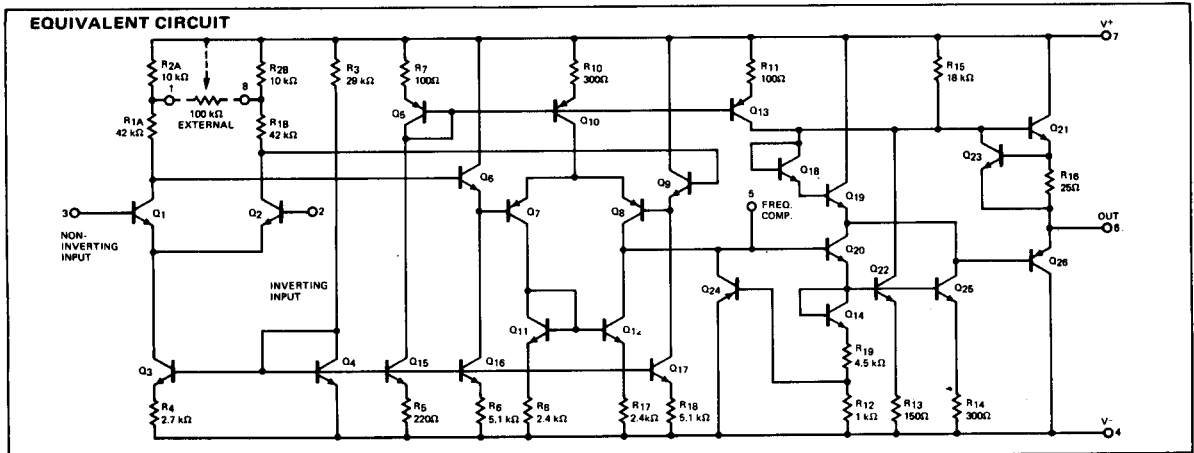

Notes on following pages

*Planar is a patented Fairchild process.

FAIRCHILD LINEAR INTEGRATED CIRCUITS • $\mu A725$

$\mu A725$

ELECTRICAL CHARACTERISTICS ($V_S = \pm 15$ V, $T_A = 25^\circ\text{C}$ unless otherwise specified)

PARAMETER	TEST CONDITIONS	MIN	TYP	MAX	UNITS
Input Offset Voltage (Without external trim)	$R_S \leq 10$ k Ω		0.5	1.0	mV
Input Offset Current			2.0	20	nA
Input Bias Current			42	100	nA
Input Noise Voltage	$f_o = 10$ Hz		15		nV/ $\sqrt{\text{Hz}}$
	$f_o = 100$ Hz		9.0		nV/ $\sqrt{\text{Hz}}$
	$f_o = 1$ kHz		8.0		nV/ $\sqrt{\text{Hz}}$
Input Noise Current	$f_o = 10$ Hz		1.0		pA/ $\sqrt{\text{Hz}}$
	$f_o = 100$ Hz		0.3		pA/ $\sqrt{\text{Hz}}$
	$f_o = 1$ kHz		0.15		pA/ $\sqrt{\text{Hz}}$
Input Resistance			1.5		M Ω
Input Voltage Range		± 13.5	± 14		V
Large Signal Voltage Gain	$R_L \geq 2$ k Ω ; $V_{OUT} = \pm 10$ V	1,000,000	3,000,000		V/V
Common Mode Rejection Ratio	$R_S \leq 10$ k Ω	110	120		dB
Power Supply Rejection Ratio	$R_S \leq 10$ k Ω		2.0	10	$\mu\text{V/V}$
Output Voltage Swing	$R_L \geq 10$ k Ω	± 12	± 13.5		V
	$R_L \geq 2$ k Ω	± 10	± 13.5		V
Output Resistance			150		Ω
Power Consumption			80	105	mW

The following specifications apply for $-55^\circ\text{C} \leq T_A \leq +125^\circ\text{C}$ unless otherwise specified:

Input Offset Voltage (Without external trim)	$R_S \leq 10$ k Ω			1.5	mV
Average Input Offset Voltage Drift (Without external trim)	$R_S = 50$ Ω		2.0	5.0	$\mu\text{V}/^\circ\text{C}$
Average Input Offset Voltage Drift (With external trim)	$R_S = 50$ Ω		0.6		$\mu\text{V}/^\circ\text{C}$
Input Offset Current	$T_A = +125^\circ\text{C}$		1.2	20	nA
	$T_A = -55^\circ\text{C}$		7.5	40	nA
Average Input Offset Current Drift			35	150	pA/ $^\circ\text{C}$
Input Bias Current	$T_A = +125^\circ\text{C}$		20	100	nA
	$T_A = -55^\circ\text{C}$		80	200	nA
Large Signal Voltage Gain	$R_L \geq 2$ k Ω , $T_A = +125^\circ\text{C}$	1,000,000			V/V
	$R_L \geq 2$ k Ω , $T_A = -55^\circ\text{C}$	250,000			V/V
Common Mode Rejection Ratio	$R_S \leq 10$ k Ω	100			dB
Power Supply Rejection Ratio	$R_S \leq 10$ k Ω			20	$\mu\text{V/V}$
Output Voltage Swing	$R_L \geq 2$ k Ω	± 10			V

NOTES:

- Rating applies to ambient temperatures up to 70°C . Above 70°C ambient derate linearly at 6.3 mW/ $^\circ\text{C}$.
- For supply voltages less than ± 22 V, the absolute maximum input voltage is equal to the supply voltage.

FAIRCHILD LINEAR INTEGRATED CIRCUITS • $\mu A725$

TYPICAL PERFORMANCE CURVES FOR ALL TYPES (Unless Otherwise Specified)

**INPUT OFFSET CURRENT
AS A FUNCTION
OF TEMPERATURE
 $\mu A725A$ AND $\mu A725$**

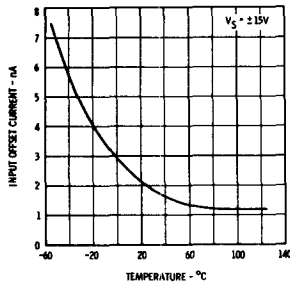

**INPUT OFFSET CURRENT
AS A FUNCTION
OF TEMPERATURE
 $\mu A725C$ AND $\mu A725E$**

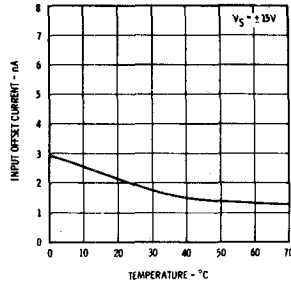

**INPUT BIAS CURRENT
AS A FUNCTION
OF TEMPERATURE
 $\mu A725A$ AND $\mu A725$**

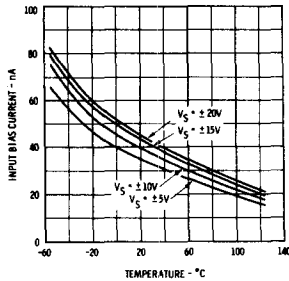

**INPUT BIAS CURRENT
AS A FUNCTION
OF TEMPERATURE
 $\mu A725C$ AND $\mu A725E$**

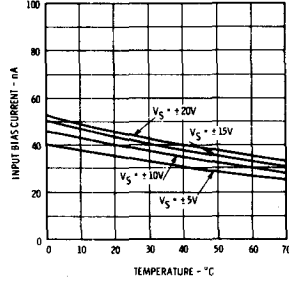

**COMMON MODE REJECTION
RATIO AS A FUNCTION
OF TEMPERATURE**

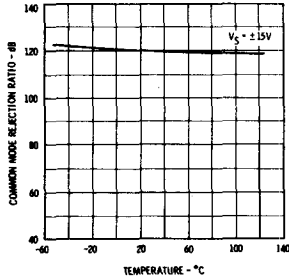

**SUPPLY VOLTAGE
REJECTION RATIO
AS A FUNCTION
OF TEMPERATURE**

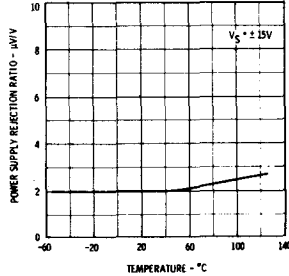

**OUTPUT VOLTAGE SWING
AS A FUNCTION
OF TEMPERATURE**

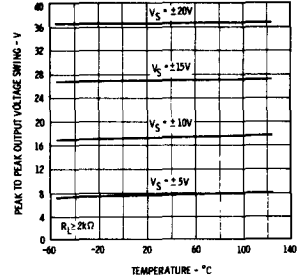

**COMMON MODE REJECTION
RATIO AS A FUNCTION
OF SUPPLY VOLTAGE**

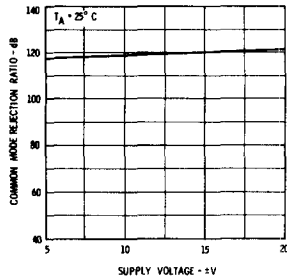

**DC CLOSED LOOP
VOLTAGE GAIN ERROR
AS A FUNCTION
OF SOURCE RESISTANCE**

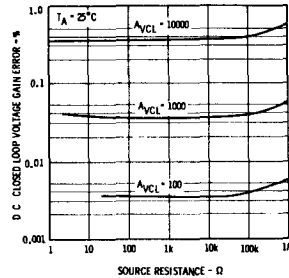

**COMMON MODE INPUT
VOLTAGE RANGE AS A
FUNCTION OF
SUPPLY VOLTAGE**

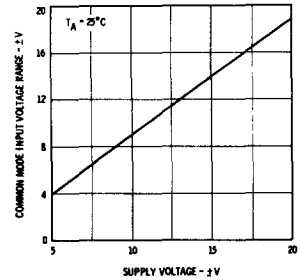

TYPICAL PERFORMANCE CURVES FOR ALL TYPES (Unless Otherwise Specified)

INPUT OFFSET VOLTAGE DRIFT AS A FUNCTION OF TIME

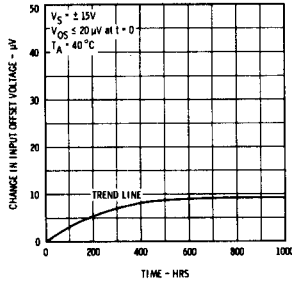

STABILIZATION TIME OF INPUT OFFSET VOLTAGE FROM POWER TURN ON

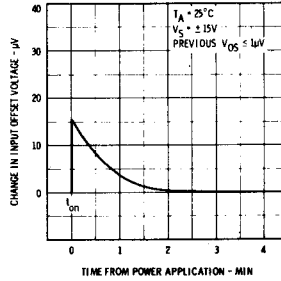

CHANGE IN INPUT OFFSET VOLTAGE DUE TO THERMAL SHOCK AS A FUNCTION OF TIME

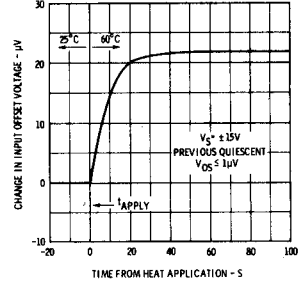

INPUT NOISE VOLTAGE AS A FUNCTION OF FREQUENCY

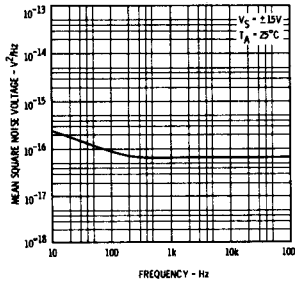

INPUT NOISE CURRENT AS A FUNCTION OF FREQUENCY

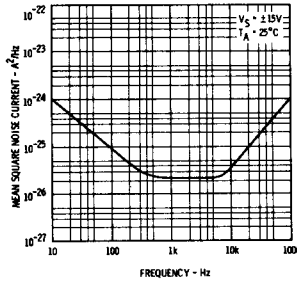

BROAD BAND NOISE FOR VARIOUS BANDWIDTHS

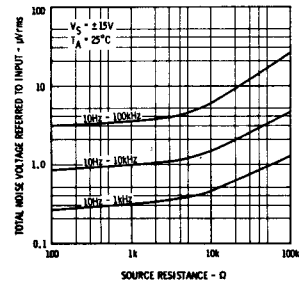

NARROW BAND SPOT NOISE FIGURE CONTOURS

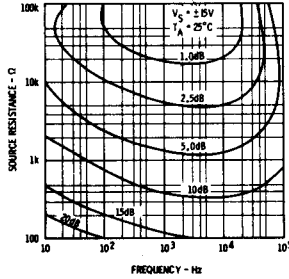

NOISE FIGURE AS A FUNCTION OF SOURCE RESISTANCE

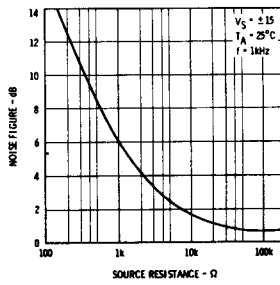

EQUIVALENT INPUT NOISE VOLTAGE DUE TO EXTERNAL COMMON MODE NOISE AS A FUNCTION OF FREQUENCY

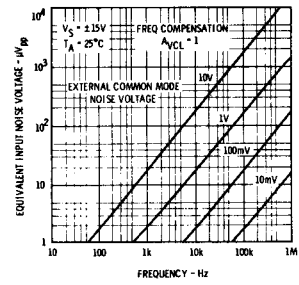

EQUIVALENT INPUT RIPPLE VOLTAGE DUE TO POWER SUPPLY RIPPLE AS A FUNCTION OF FREQUENCY

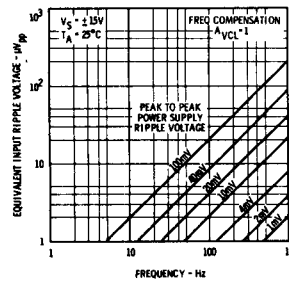

ABSOLUTE MAXIMUM POWER DISSIPATION AS A FUNCTION OF AMBIENT TEMPERATURE

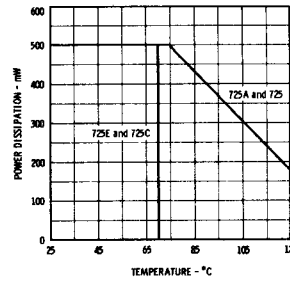

POWER CONSUMPTION AS A FUNCTION OF TEMPERATURE

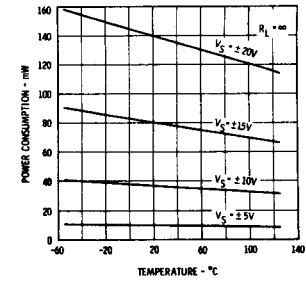

TYPICAL PERFORMANCE CURVES FOR ALL TYPES

OPEN LOOP VOLTAGE GAIN AS A FUNCTION OF FREQUENCY USING RECOMMENDED COMPENSATION NETWORKS

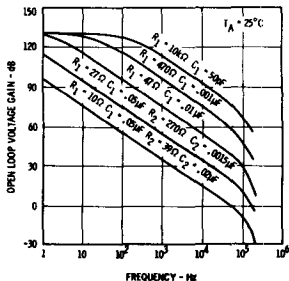

VALUES FOR SUGGESTED COMPENSATION NETWORKS FOR VARIOUS CLOSED LOOP VOLTAGE GAINS

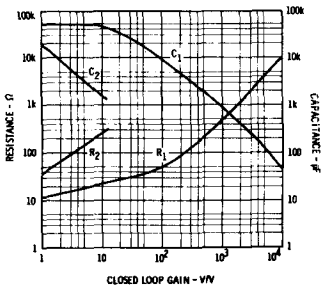

FREQUENCY RESPONSE FOR VARIOUS CLOSED LOOP GAINS USING RECOMMENDED COMPENSATION NETWORKS

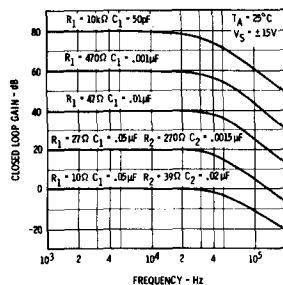

OUTPUT VOLTAGE SWING AS A FUNCTION OF FREQUENCY FOR RECOMMENDED COMPENSATION NETWORKS

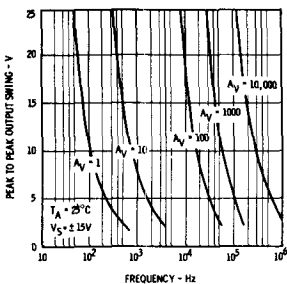

SLEW RATE AS A FUNCTION OF CLOSED LOOP GAIN USING RECOMMENDED COMPENSATION NETWORKS

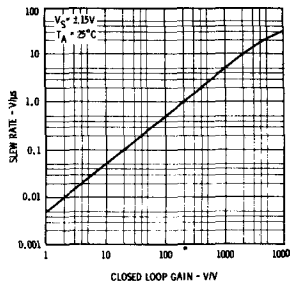

VOLTAGE OFFSET NULL CIRCUIT

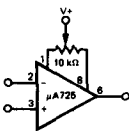

COMPENSATION COMPONENT VALUES

A_V	R_1 (Ω)	C_1 (μF)	R_2 (Ω)	C_2 (μF)
10,000	10 k	50 pF	—	—
1,000	470	.001	—	—
100	47	.01	—	—
10	27	.05	270	.0015
1	10	.05	39	.02

FREQUENCY COMPENSATION CIRCUIT

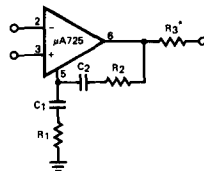

*Use $R_3 = 51\Omega$ when the amplifier is operated with capacitive load.

TRANSIENT RESPONSE TEST CIRCUIT

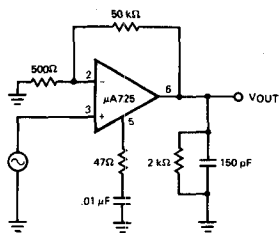

Pin numbers are shown for metal can only.

TRANSIENT RESPONSE

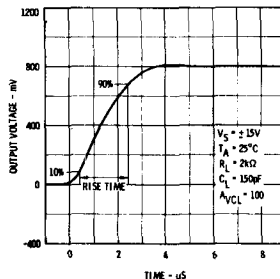

TYPICAL APPLICATIONS

PRECISION AMPLIFIER - $A_{VCL} = 1000$

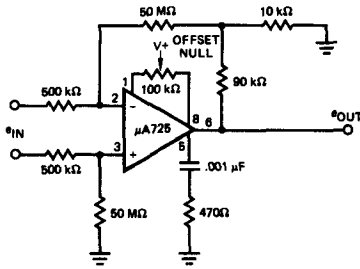

CHARACTERISTICS:
 $A_V = 1000 = 60 \text{ dB}$
 DC Gain Error = 0.05%
 Bandwidth = 1 kHz for -0.05% error
 Diff. Input Res. = 1 MΩ
 Typical amplifying capability
 $e_{IN} = 10 \mu\text{V}$ on $V_{CMI} = 1.0 \text{ V}$
 Caution: Minimize Stray Capacitance

ACTIVE FILTER - BAND PASS WITH 60 dB GAIN

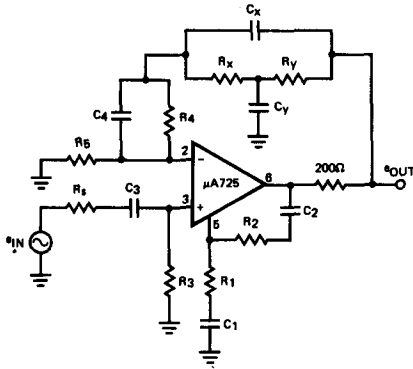

ACTIVE FILTER
 FREQUENCY RESPONSE

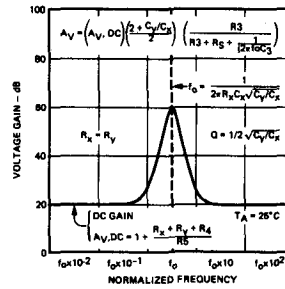

OPEN LOOP VOLTAGE GAIN TEST CIRCUIT

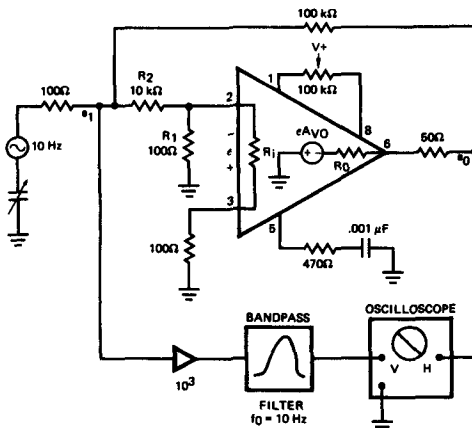

$$A_{VO} \approx \frac{e_0}{e_1} \left(\frac{R_2 R_i + R_1 R_i + R_1 R_2}{R_1 R_i} \right) = \frac{e_0}{e_1} 101$$

TYPICAL APPLICATIONS (Cont'd)

PHOTODIODE AMPLIFIER

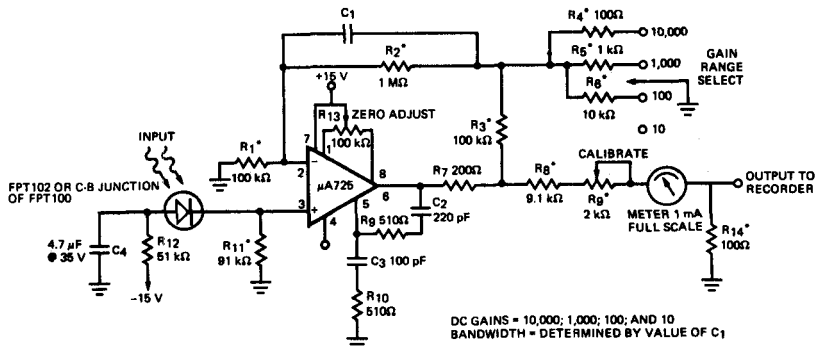

DC GAINS = 10,000; 1,000; 100; AND 10
BANDWIDTH = DETERMINED BY VALUE OF C1

NOTE: *Indicates $\pm 1\%$ metal film resistors recommended for temperature stability.

THERMOCOUPLE AMPLIFIER

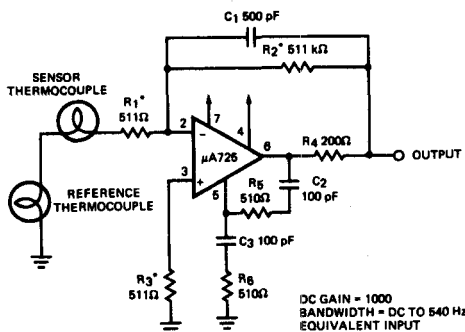

DC GAIN = 1000
BANDWIDTH = DC TO 540 Hz
EQUIVALENT INPUT NOISE = 0.24 μV_{rms}

NOTE: *Indicates $\pm 1\%$ metal film resistors recommended for temperature stability.

± 100 V COMMON MODE RANGE DIFFERENTIAL AMPLIFIER

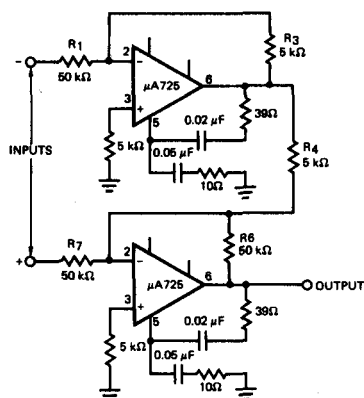

$$\frac{R1}{R6} = \frac{R3}{R4} \text{ for best CMRR}$$

$$R3 = R4$$

$$R1 = R6 = 10 R3$$

$$\text{Gain} = \frac{R6}{R7}$$

INSTRUMENTATION AMPLIFIER WITH HIGH COMMON MODE REJECTION

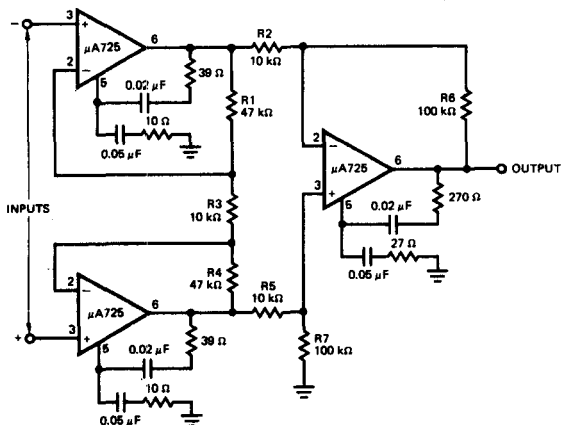

$$\frac{R2}{R5} = \frac{R6}{R7} \text{ for best CMR}$$

$$R1 = R4$$

$$R2 = R5$$

$$\text{Gain} = \frac{R6}{R2} \left(1 + \frac{2 R1}{R3} \right)$$