

DAEWOO

Service Manual

MINI COMPONENT SYSTEM

Model : DV-115



DAEWOO ELECTRONICS CO., LTD.

9. Schematic Diagram

Model : DV-115

-. BLOCK Diagram

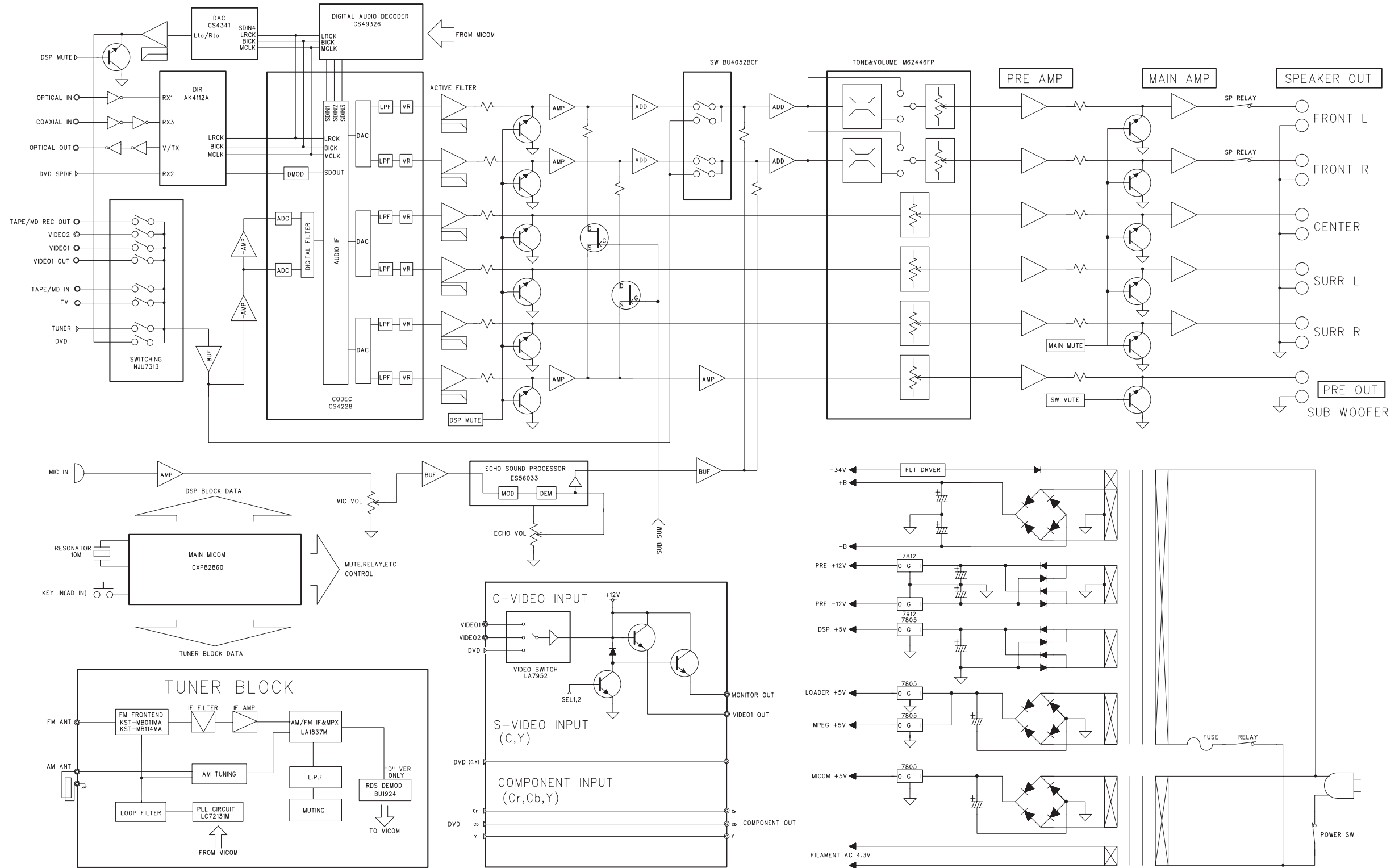

9. Schematic Diagram

1) DV-115 Front Schematic Diagram - FRONT

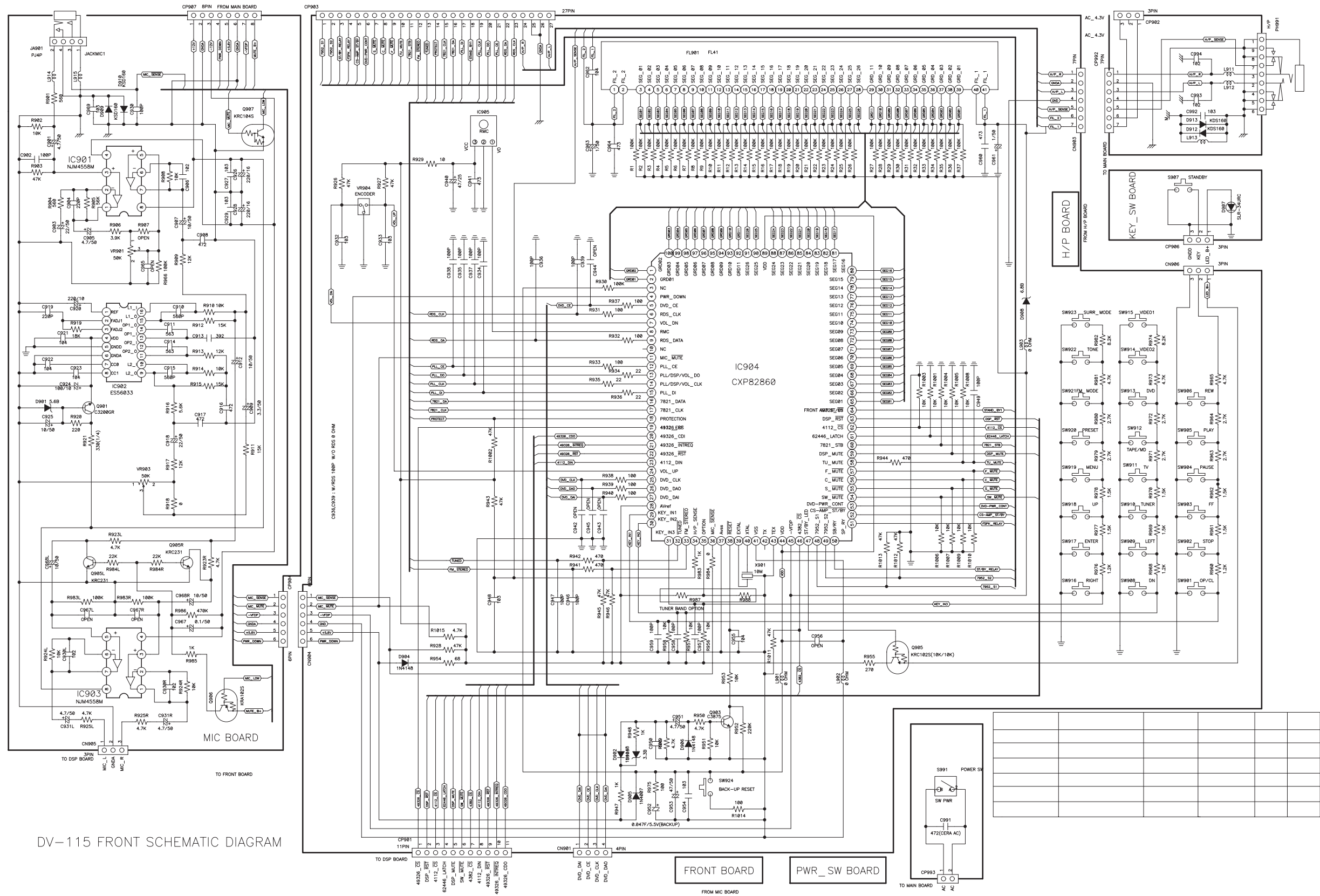

DV-115 FRONT SCHEMATIC DIAGRAM

9. Schematic Diagram

Model : DV-115

- DSP-1

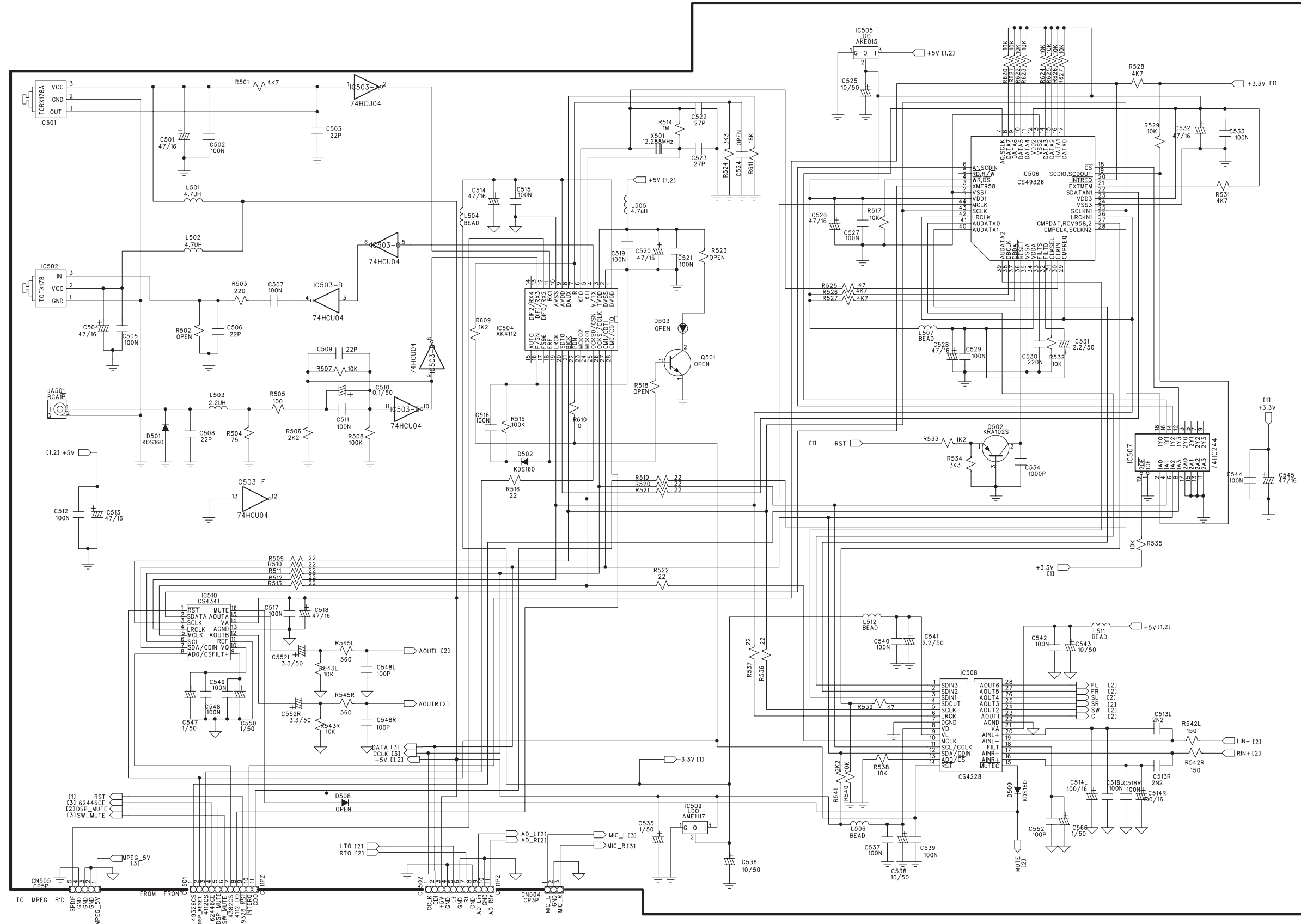

9. Schematic Diagram

Model : DV-115

- DSP-3

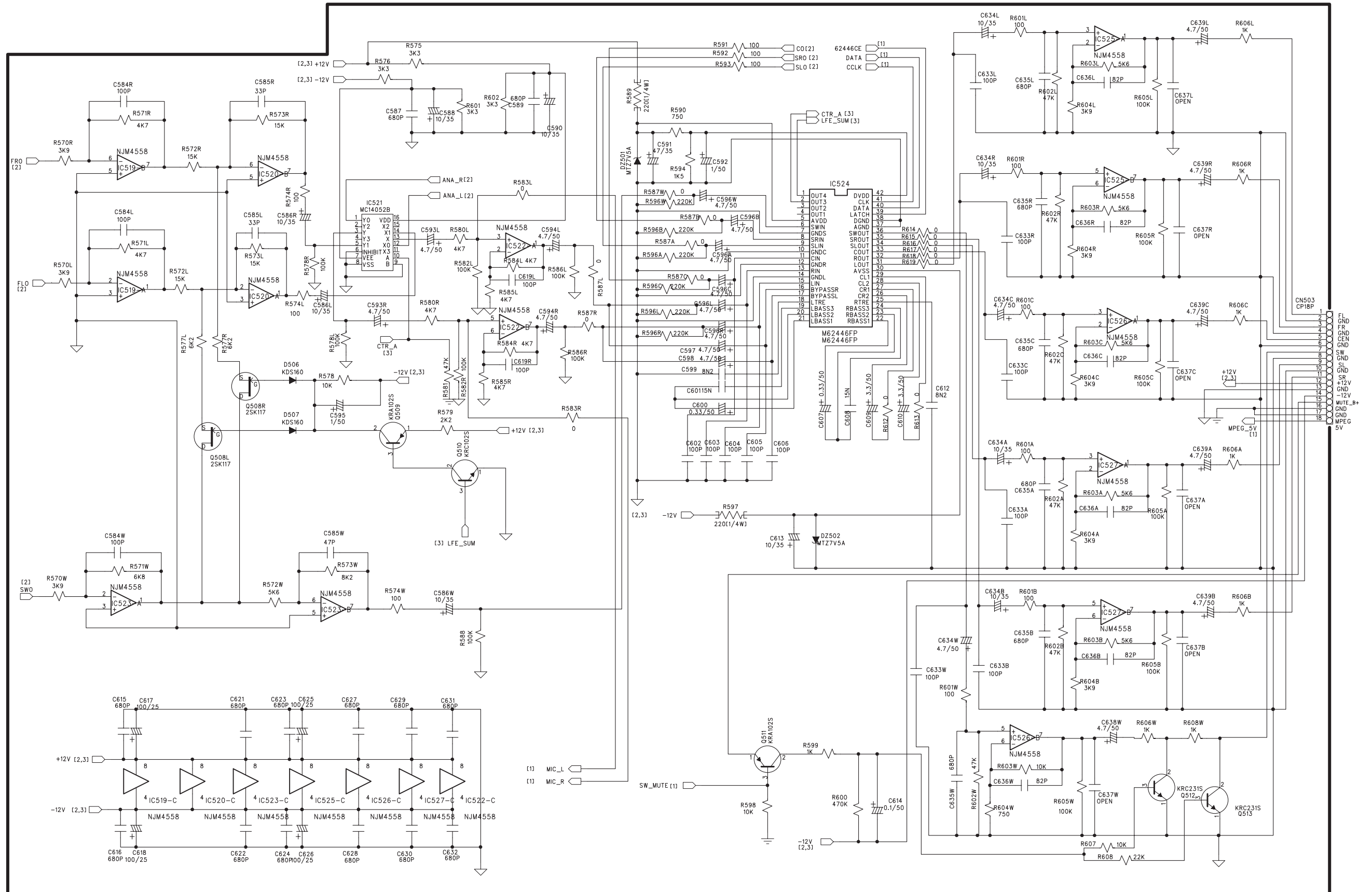

9. Schematic Diagram

Model : DV-115

- MPEG

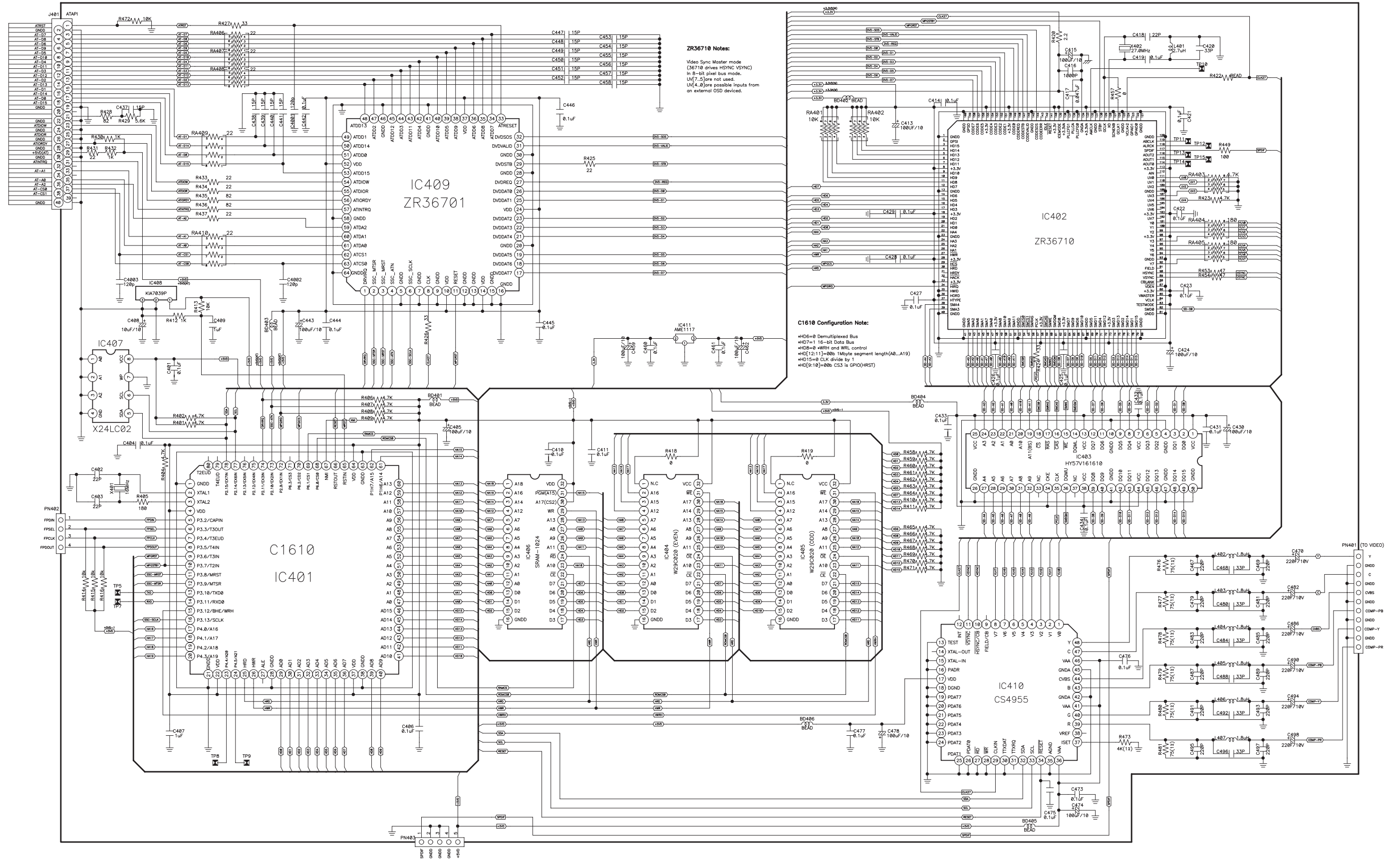

9. Schematic Diagram

- Main Schematic Diagram 1) Power Schematic Diagram

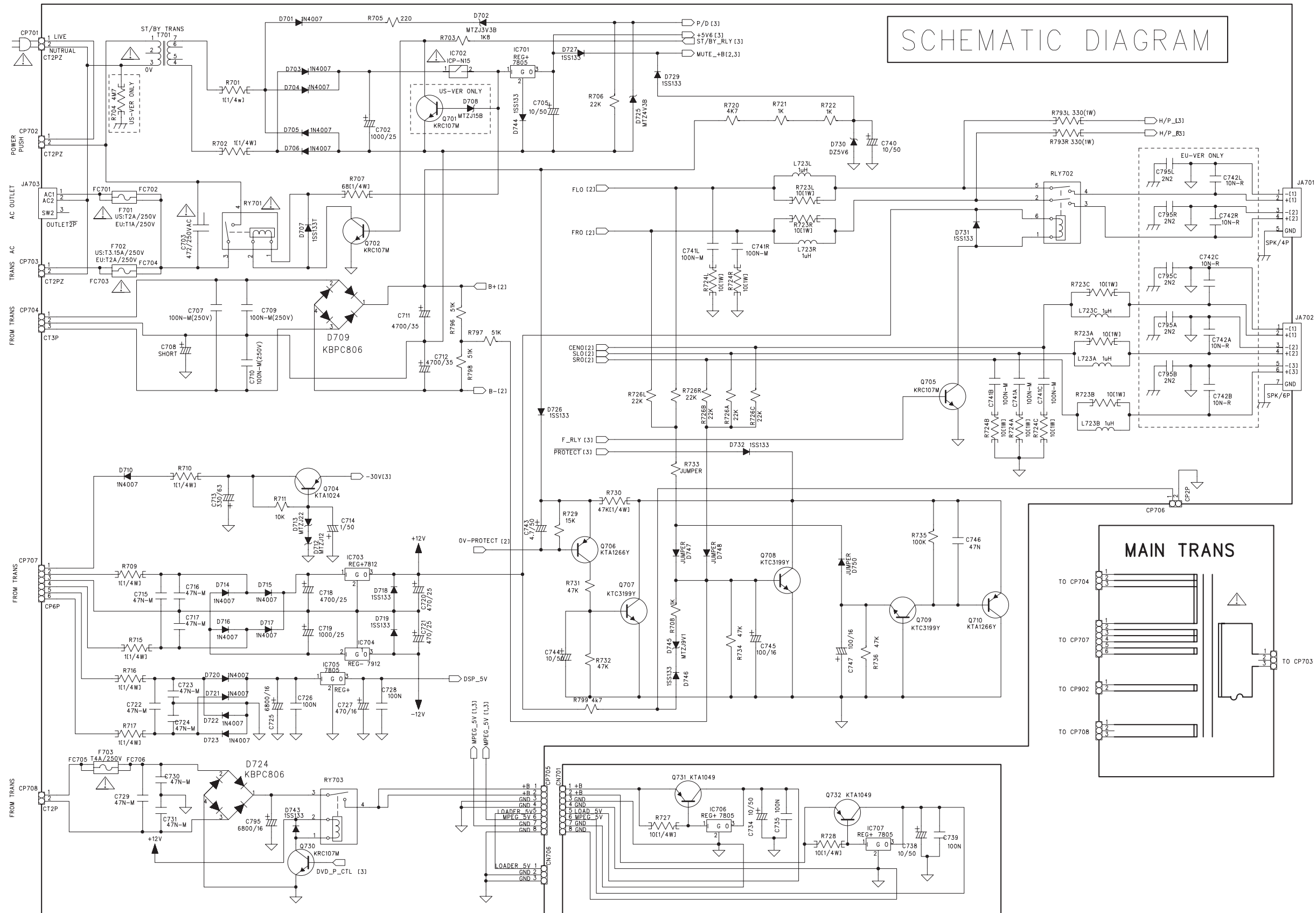

9. Schematic Diagram

- Main Schematic Diagram

2) Amp Schematic Diagram

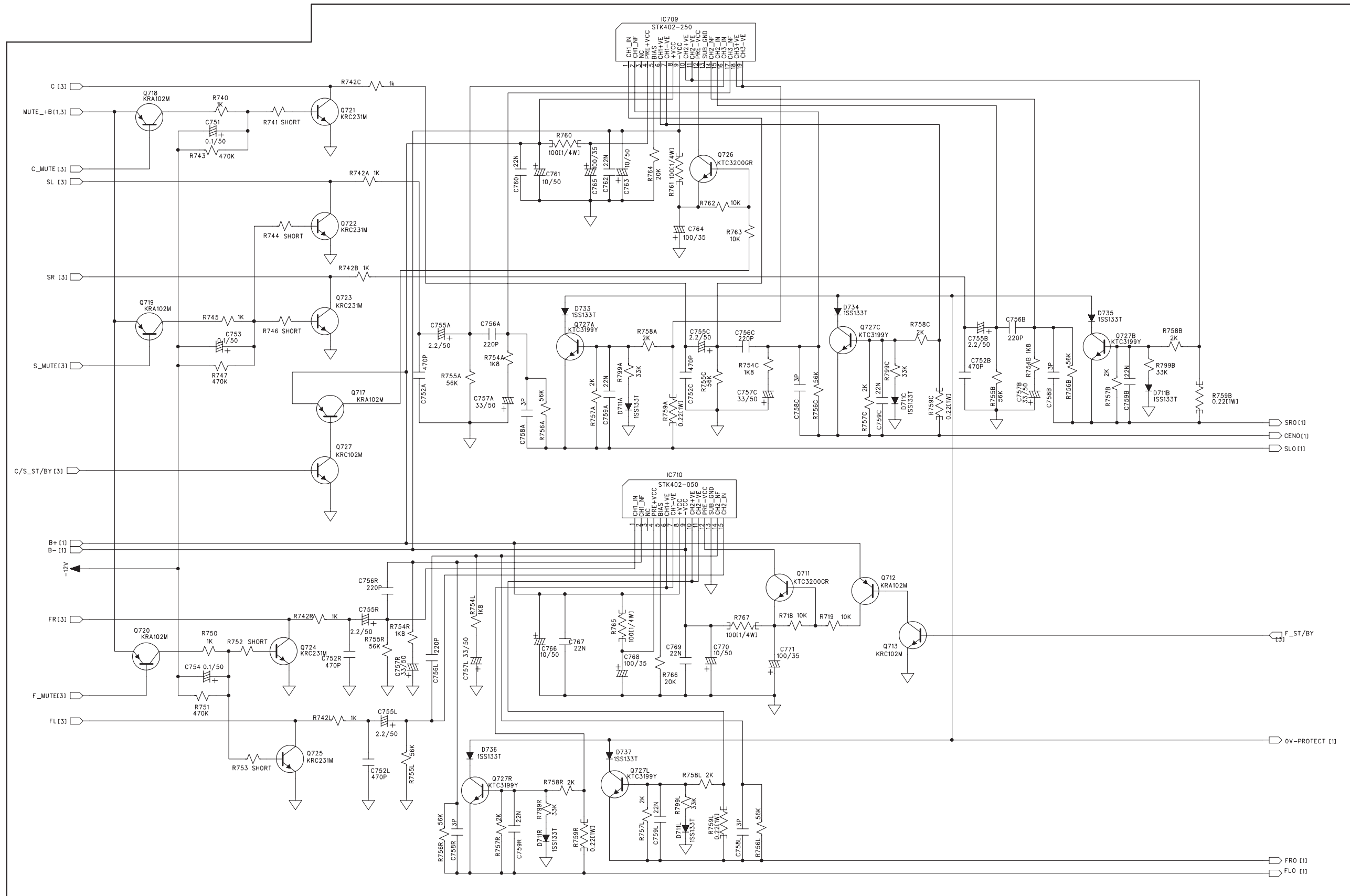

9. Schematic Diagram

- Main Schematic Diagram 3) Input Schematic Diagram

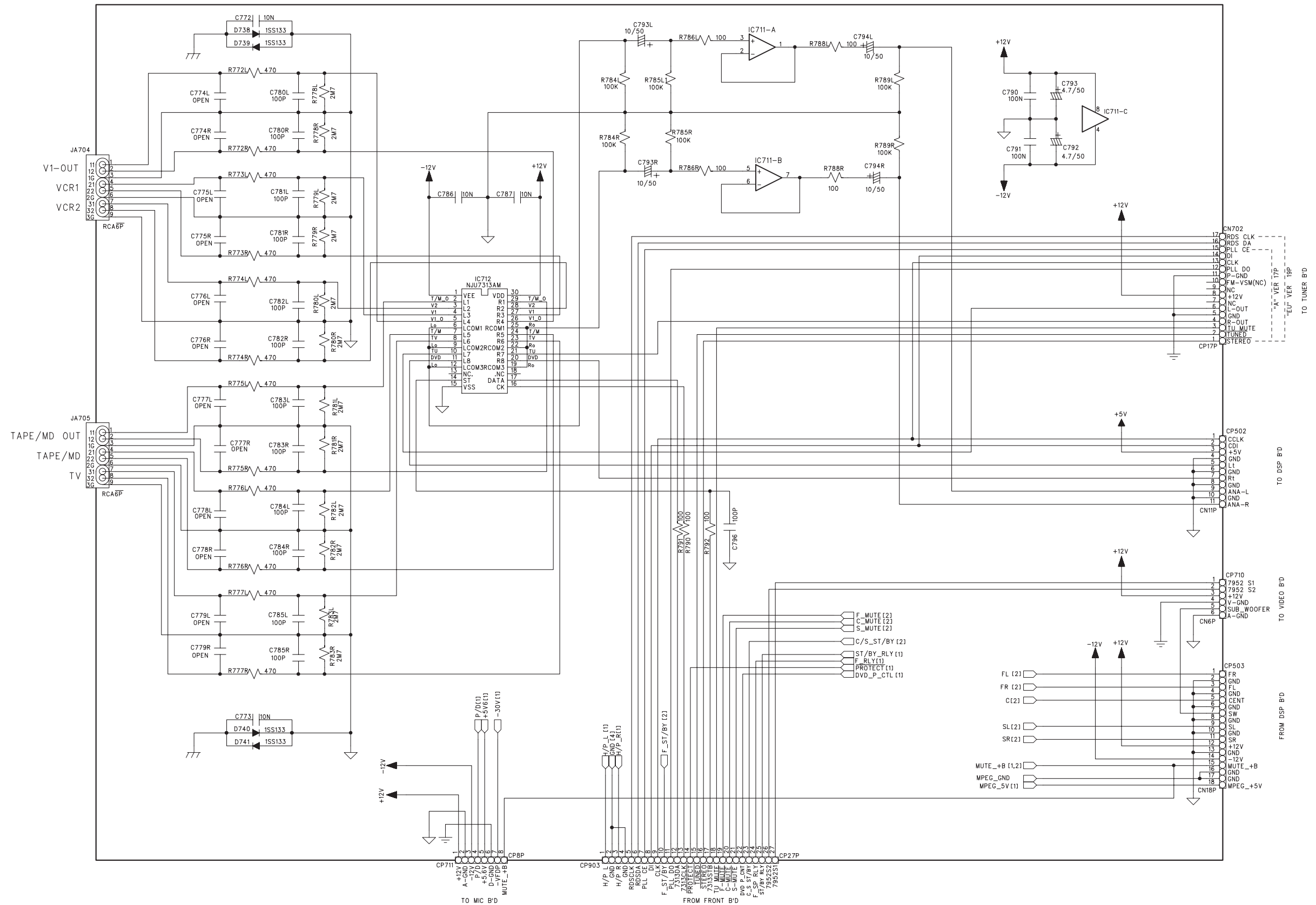

9. Schematic Diagram

- Main Schematic Diagram
- 4) Video Schematic Diagram

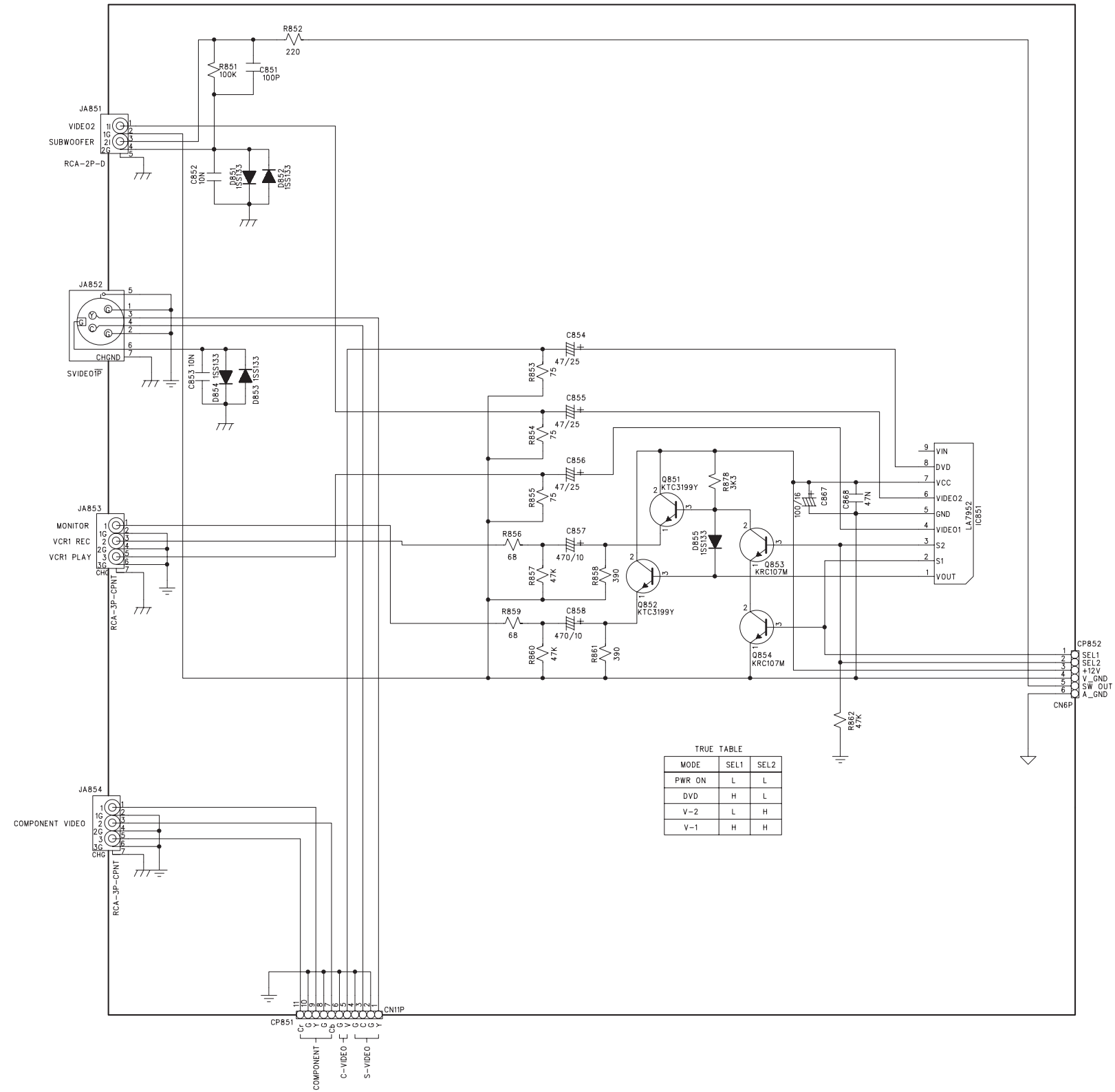

9. Schematic Diagram

- WIRING Diagram 1) DV-115 WIRING Diagram

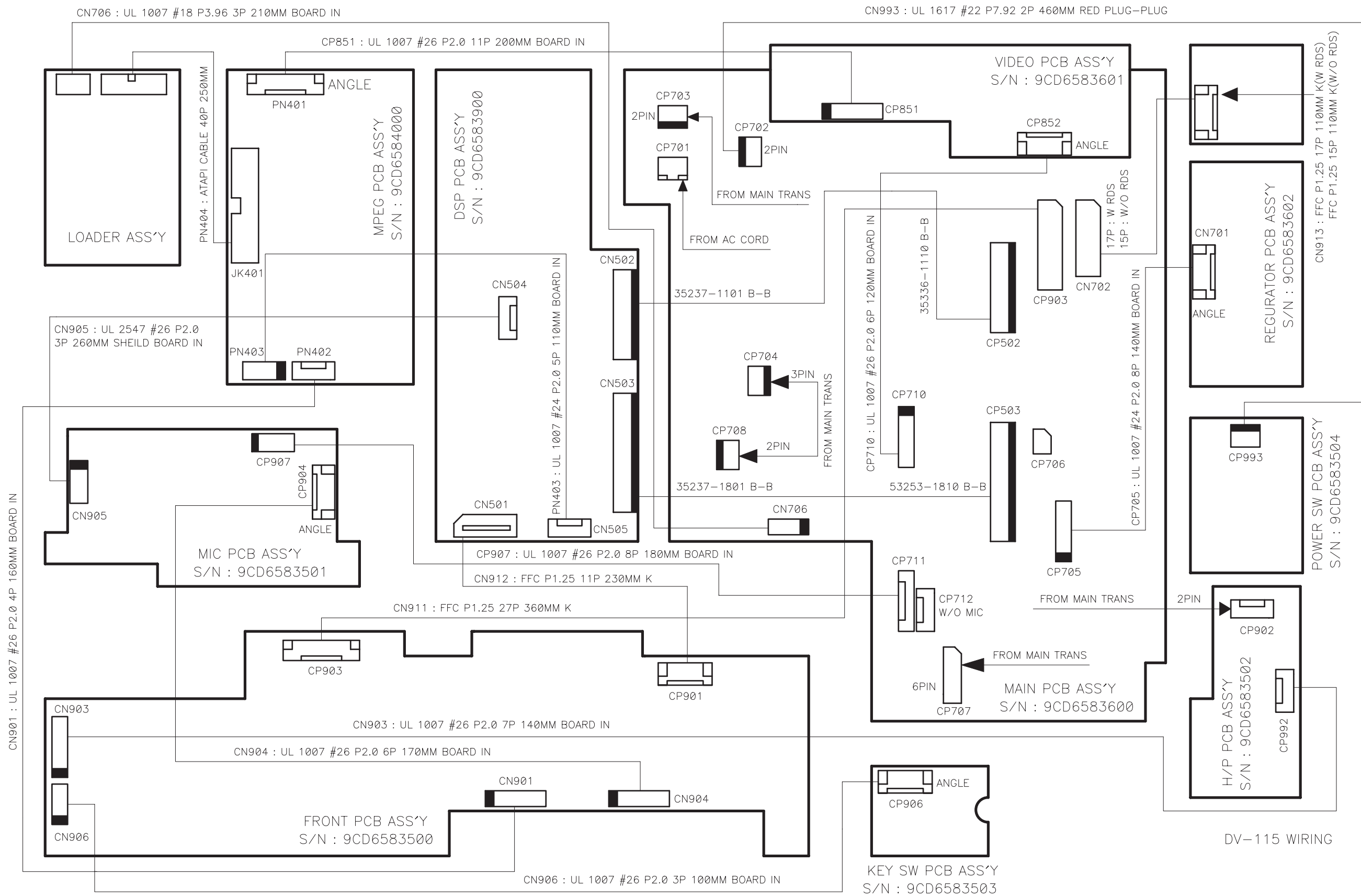

9. Schematic Diagram

Model : DV-115

- LEVEL Diagram

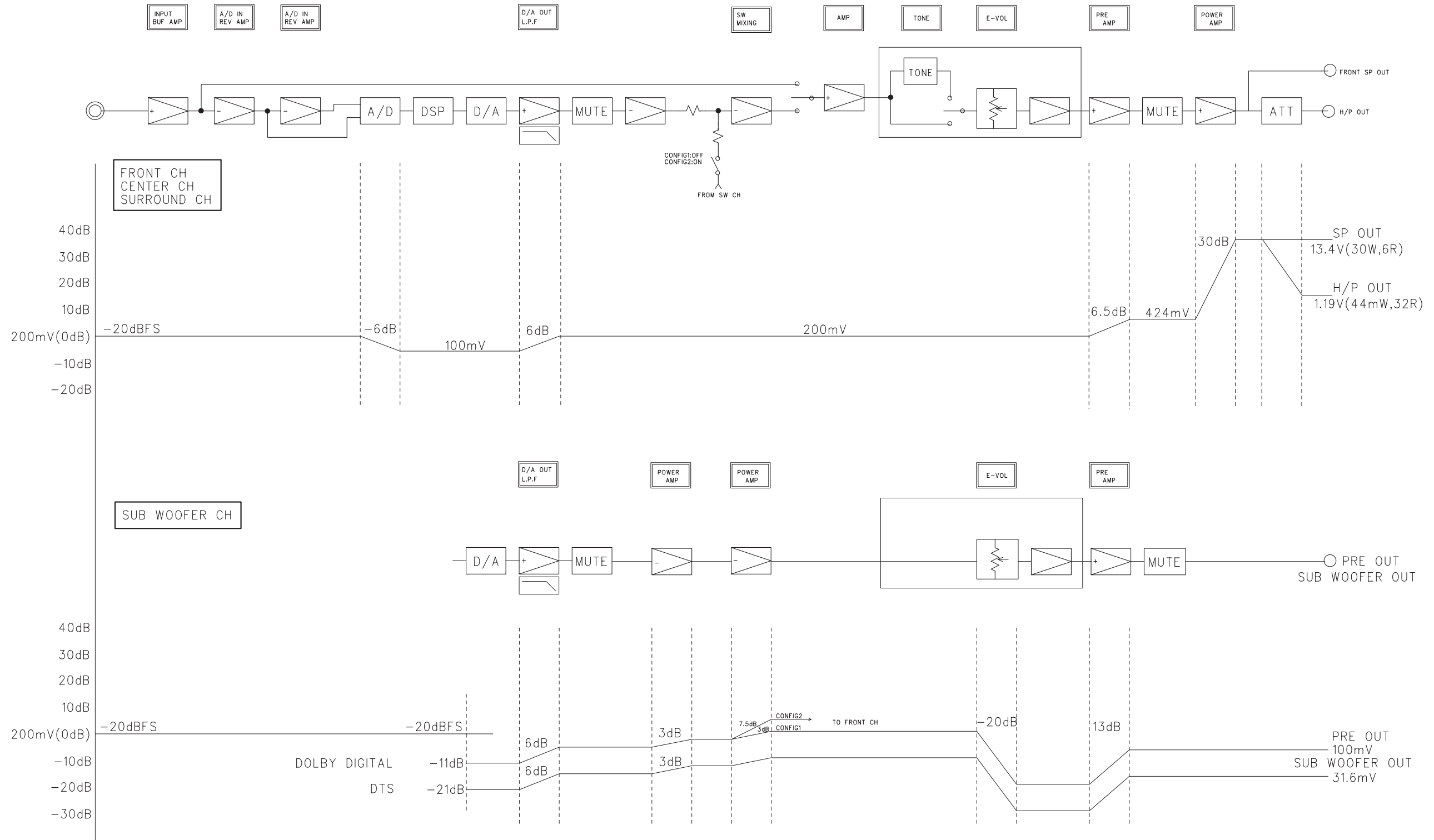

13. Electrical Parts List

Model : DV-115

NO	PART-NAME	LOCATION	PART-CODE	PART-DESC	REMARKS	NO	PART-NAME	LOCATION	PART-CODE	PART-DESC	REMARKS
15	C CHIP CERA	C416	HCBK102KBA	50V X7R 1000PF K 1608		67	IC RESET	IC408	1K1A7039AF	KIA7039AF	
16	C CHIP CERA	C417	HCBK473KBA	50V X7R 0.047MF K 1608		68	IC ATAPI I/F	IC409	1ZR36701--	ZR36701P	
17	C CHIP CERA	C418	HCQK220JBA	50V CH 22PF J 1608		69	IC VIDEO ENCODER	IC410	1CS4955---	CS4955	
18	C CHIP CERA	C419	HCBK104KBA	50V X7R 0.1MF K 1608		70	IC REGULATOR	IC411	1AME1117CC	AME1117CCCT (TO-252)	
19	C CHIP CERA	C420	HCQK330JBA	50V CH 33PF J 1608		71	JACK ATAPI	JK401	9736324700	40P ATAPI	
20	C CHIP CERA	C421-423	HCBK104KBA	50V X7R 0.1MF K 1608		72	COIL CHIP	L401	HLC279J03A	2.7UH CHIP 3216	
21	C ELECTRO	C424	CEXF1E101E	25V RM 100MF (6.3X11) TP		73	COIL CHIP	L402-407	HLC189J02A	1.8UH CHIP 3216	
22	C CHIP CERA	C425-429	HCBK104KBA	50V X7R 0.1MF K 1608		74	CONN WAFER	PN401	9728810700	2.0MM PH-11AW 11P	
23	C ELECTRO	C430	CEXF1E101E	25V RM 100MF (6.3X11) TP		75	CONN WAFER	PN402	9728810800	2.0MM PH-4A 4P	
24	C CHIP CERA	C431-434	HCBK104KBA	50V X7R 0.1MF K 1608		76	CONN AS	PN403	9728810100	#24 P2.0 5P 120MM UL 1007	
25	C CHIP CERA	C437-441	HCQK150JBA	50V CH 15PF J 1608		77	CABLE ATAPI	PN404	9728811100	ATAPI CABLE 40P 250MM	
26	C CHIP CERA	C442	HCBK104KBA	50V X7R 0.1MF K 1608		78	R CHIP	R401-402	HRFT472JBA	1/10 4.7K OHM J 1608	
27	C ELECTRO	C443	CEXF1E101E	25V RM 100MF (6.3X11) TP		79	R CHIP	R404	HRFT472JBA	1/10 4.7K OHM J 1608	
28	C CHIP CERA	C444-446	HCBK104KBA	50V X7R 0.1MF K 1608		80	R CHIP	R405	HRFT181JBA	1/10 180 OHM J 1608	
29	C CHIP CERA	C447-458	HCQK150JBA	50V CH 15PF J 1608		81	R CHIP	R406-411	HRFT472JBA	1/10 4.7K OHM J 1608	
30	C ELECTRO	C459	CEXF1E101E	25V RM 100MF (6.3X11) TP		82	R CHIP	R412	HRFT102JBA	1/10 1K OHM J 1608	
31	C CHIP CERA	C460-461	HCBK104KBA	50V X7R 0.1MF K 1608		83	R CHIP	R413-416	HRFT103JBA	1/10 10K OHM J 1608	
32	C ELECTRO	C462	CEXF1E101E	25V RM 100MF (6.3X11) TP		84	R CHIP	R420	HRFT229JCA	1/10 2.2 OHM J 2012	
33	C CHIP CERA	C467	HCQK221JBA	50V CH 220PF J 1608		85	R CHIP	R422	HRFT330JBA	1/10 33 OHM J 1608	
34	C CHIP CERA	C468	HCQK330JBA	50V CH 33PF J 1608		86	R CHIP	R423	HRFT472JBA	1/10 4.7K OHM J 1608	
35	C CHIP CERA	C469	HCQK221JBA	50V CH 220PF J 1608		87	R CHIP	R424	HRFT330JBA	1/10 33 OHM J 1608	
36	CLECTRO	C470	CEXF1C221E	RM 16V 220MF 6.3X11 TAT		88	R CHIP	R425	HRFT220JBA	1/10W 22 OHM J 1608	
37	C CHIP CERA	C473	HCBK104KBA	50V X7R 0.1MF K 1608		89	R CHIP	R426-427	HRFT330JBA	1/10 33 OHM J 1608	
38	C ELECTRO	C474	CEXF1E101E	25V RM 100MF (6.3X11) TP		90	R CHIP	R428	HRFT820JBA	1/10 82 OHM J 1608	
39	C CHIP CERA	C475-477	HCBK104KBA	50V X7R 0.1MF K 1608		91	R CHIP	R429	HRFT562JBA	1/10 5.6K OHM J 1608	
40	C ELECTRO	C478	CEXF1E101E	25V RM 100MF (6.3X11) TP		92	R CHIP	R430	HRFT102JBA	1/10 1K OHM J 1608	
41	C CHIP CERA	C479	HCQK221JBA	50V CH 220PF J 1608		93	R CHIP	R431	HRFT220JBA	1/10W 22 OHM J 1608	
42	C CHIP CERA	C480	HCQK330JBA	50V CH 33PF J 1608		94	R CHIP	R432	HRFT102JBA	1/10 1K OHM J 1608	
43	C CHIP CERA	C481	HCQK221JBA	50V CH 220PF J 1608		95	R CHIP	R433-434	HRFT220JBA	1/10W 22 OHM J 1608	
44	CLECTRO	C482	CEXF1C221E	RM 16V 220MF 6.3X11 TAT		96	R CHIP	R435-436	HRFT820JBA	1/10 82 OHM J 1608	
45	C CHIP CERA	C483	HCQK221JBA	50V CH 220PF J 1608		97	R CHIP	R437	HRFT220JBA	1/10W 22 OHM J 1608	
46	C CHIP CERA	C484	HCQK330JBA	50V CH 33PF J 1608		98	R CHIP	R449	HRFT101JBA	1/10 100 OHM J 1608	
47	C CHIP CERA	C485	HCQK221JBA	50V CH 220PF J 1608		99	R CHIP	R453-454	HRFT470JBA	1/10 47 OHM J 1608	
48	CLECTRO	C486	CEXF1C221E	RM 16V 220MF 6.3X11 TAT		100	R CHIP	R457	HRFT000-BA	1/10 0 OHM 1608	
49	C CHIP CERA	C487	HCQK221JBA	50V CH 220PF J 1608		101	R CHIP	R458-466	HRFT472JBA	1/10 4.7K OHM J 1608	
50	C CHIP CERA	C488	HCQK330JBA	50V CH 33PF J 1608		102	R CHIP	R469-471	HRFT472JBA	1/10 4.7K OHM J 1608	
51	C CHIP CERA	C489	HCQK221JBA	50V CH 220PF J 1608		103	R CHIP	R472	HRFT103JBA	1/10 10K OHM J 1608	
52	CLECTRO	C490	CEXF1C221E	RM 16V 220MF 6.3X11 TAT		104	R CHIP	R473	HRFT402FBA	1/10 4.0K OHM F 1608(1%)	
53	C CHIP CERA	C491	HCQK221JBA	50V CH 220PF J 1608		105	R CHIP	R474-475	HRFT101JBA	1/10 100 OHM J 1608	
54	C CHIP CERA	C492	HCQK330JBA	50V CH 33PF J 1608		106	R CHIP	R476-481	HRFT750JBA	1/10 75 OHM J 1608	
55	C CHIP CERA	C493	HCQK221JBA	50V CH 220PF J 1608		107	R ARRAY	RA401-402	HRTT8X103J	MNR 14X0ABJ 470 (10KX4)	
56	CLECTRO	C494	CEXF1C221E	RM 16V 220MF 6.3X11 TAT		108	R ARRAY	RA403	HRTT8X472J	MNR 14X0ABJ 470 (4.7KX4)	
57	C CHIP CERA	C495	HCQK221JBA	50V CH 220PF J 1608		109	R ARRAY	RA404-406	HRTT8X181J	MNR 14X0ABJ 470 (180X4)	
58	C CHIP CERA	C496	HCQK330JBA	50V CH 33PF J 1608		110	R ARRAY	RA406-410	HRTT8X220J	MNR 14X0ABJ 470 (22X4)	
59	C CHIP CERA	C497	HCQK221JBA	50V CH 220PF J 1608		111	X-TAL	X401	5XE16M000J	16MHZ HC-49/U (RADIAL)	
60	CLECTRO	C498	CEXF1C221E	RM 16V 220MF 6.3X11 TAT		112	X-TAL	X402	5XE27M000C	27MHZ HC-49/U 20PPM 30PF	
61	IC MICOM	IC401	1C1610----	C1610		1	PCB POWER SW AS	19000	9CDC0593D0	DV-115	
62	IC DECODER	IC402	1ZR36710--	ZR36710 DFP		2	PCB POWER SW	B001	9CD6583505	242X329	
63	IC SDRAM	IC403	1HY57V1616	HY57V1616		3	C CERA AC	C991	CH1BFE472M	4.0KV 4700PF M SD AC250V	
64	IC ROM	IC404-405	1A290021L-	A290021L		4	CONN WAFER	CP993	9728808200	VH-3A (W/O CENTER,RED)	
65	IC SRAM	IC406	11S61C1024	IS61C1024/L		5	SW POWER SPST	S991	5S40101369	SDDL-005-S PUSH	
66	IC EEPROM	IC407	1XC24C02--	XC24C02		1	PCB REG AS	12000	9CDC0589B0	DV-115	

13. Electrical Parts List

Model : DV-115

NO	PART-NAME	LOCATION	PART-CODE	PART-DESC	REMARKS
2	PCB REGURATOR	B001	9CD6583602	247X330	
3	C ELECTRO	C734	CEXF1C471V	16V RSS 470MF (10X12.5)BK	
4	C CERA	C735	CCXF1H104Z	50V F 0.1MF Z	
5	C ELECTRO	C738	CEXF1C471V	16V RSS 470MF (10X12.5)BK	
6	C CERA	C739	CCXF1H104Z	50V F 0.1MF Z	
7	CONN WAFER	CN701	9728808700	2.0MM PH-8A 8P	
8	IC REGULATOR	IC706-707	1K1A7805AP	K1A7805AP	
9	TR	Q731-732	TZTA1046Y-	KTA1046Y	
10	R METAL FILM	R727-728	RN-4Z100J-	1/4 10 OHM J	
1	PCB VIDEO AS	11000	9CDC0589A0	DV-115	
2	PCB VIDEO	B001	9CD6583601	247X330	
3	C CERA	C851	CZCH1H101J	CH 50V 100PF J AXL 52MM	
4	C CERA	C852-853	CCXF1H103Z	50V F 0.01MF Z (TAPPING)	
5	C ELECTRO	C854-856	CEXF1E470E	25V RM 47MF (5X11)	
6	C ELECTRO	C857-858	CEXF1A471E	10V RM 470ME (6.3X11)	
7	C ELECTRO	C867	CEXF1E101E	25V RM 100MF (6.3X11) TP	
8	C CERA	C868	CCXF1H473Z	50V F 0.047MF Z (TAPPING)	
9	CONN AS	CP851	9728810300	#26 P2.0 11P 220MM UL1007	
10	CONN WAFER	CP852	9728808600	2.0MM PH-6AW 6P	
11	DIODE	D851-855	DZN4148---	1N4148 AUTO 52MM	
12	IC SWITCH	IC851	1LA7952---	LA7952	
13	JACK RCA	JA851	9736323700	JE0200596N	
14	JACK S VIDEO	JA852	9736324000	C50160272N	
15	JACK RCA	JA853	9736323800	JE0301645N	
16	JACK RCA	JA854	9736323900	JE0301645G	
17	TR	Q851-852	TZTC3199Y-	KTC-3199Y TAPING	
18	TR	Q853-854	TKRC107M--	KRC107-M TAPPING(KSR1006)	
19	R CARBON FILM	R851	RD-AZ104J-	1/6 100K OHM J	
20	R CARBON FILM	R852	RD-AZ221J-	1/6 220 OHM J	
21	R CARBON FILM	R853-855	RD-AZ750J-	1/6 75 OHM J	
22	R CARBON FILM	R856	RD-AZ680J-	1/6 68 OHM J	
23	R CARBON FILM	R857	RD-AZ473J-	1/6 47K OHM J	
24	R CARBON FILM	R858	RD-AZ391J-	1/6 390 OHM J	
25	R CARBON FILM	R859	RD-AZ680J-	1/6 68 OHM J	
26	R CARBON FILM	R860	RD-AZ473J-	1/6 47K OHM J	
27	R CARBON FILM	R861	RD-AZ391J-	1/6 390 OHM J	
28	R CARBON FILM	R862	RD-AZ473J-	1/6 47K OHM J	
29	R CARBON FILM	R878	RD-AZ332J-	1/6 3.3K OHM J	