

4.4 POWER AMP ASSY AND VOLTAGE AMP ASSY

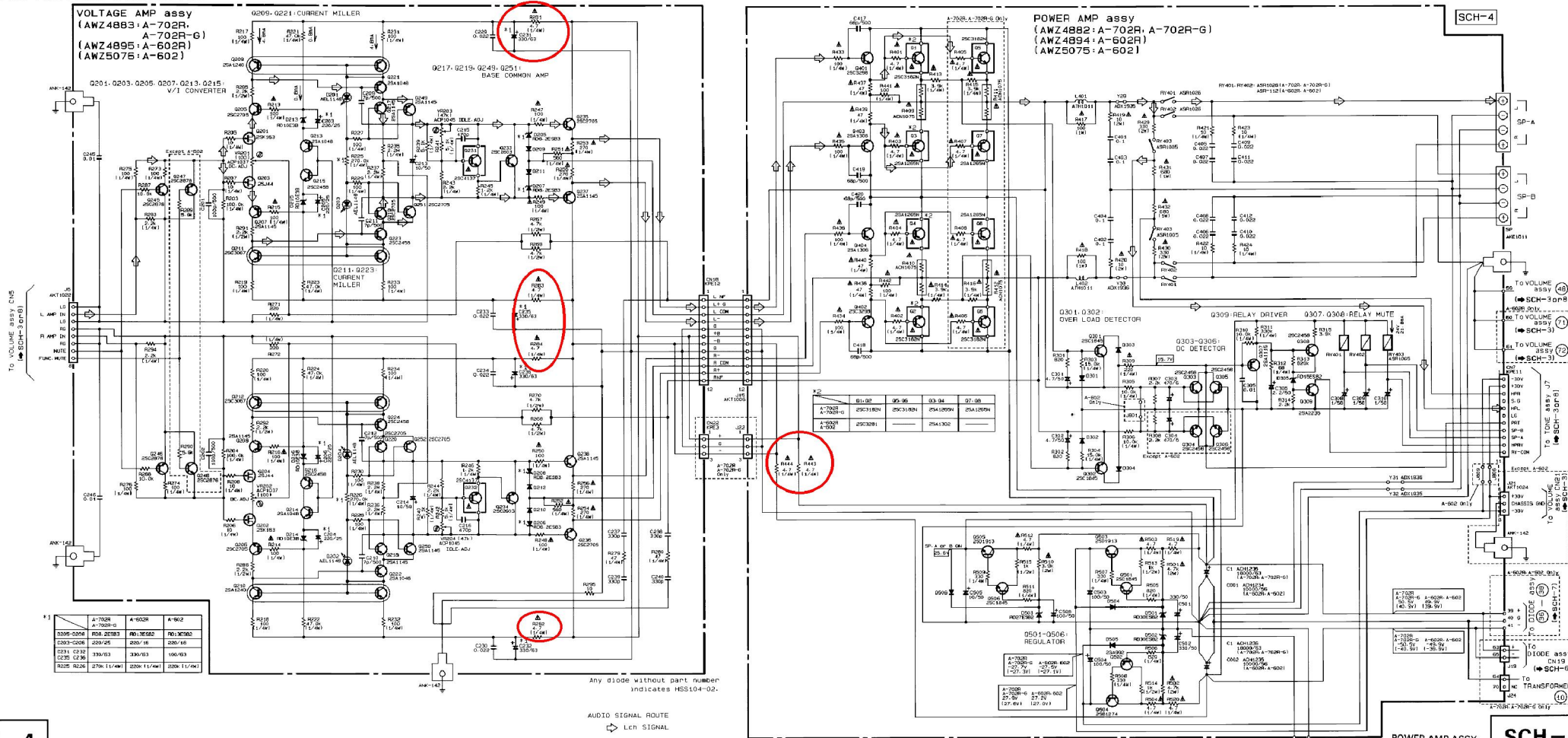

SCH-4

SCH-4

POWER AMP ASSY, VOLTAGE AMP ASSY

POWER AMP ASSY, VOLTAGE AMP ASSY

24

1

2

3

6. ADJUSTMENTS

1) IDLE CURRENT ADJUSTMENT

1. Connect the measuring instrument as Fig. 6-1. (R409 or R410)
2. Set the VOLUME CONTROL to minimum.
3. Set the POWER switch to ON.
4. Adjust VR203 (VR204) so that the voltage between both sides of R409 (R410) becomes $16\text{mV} \pm 3\text{mV}$.

Note)

After turning on the power, wait at least 5 minutes before adjustment.

2) DC OFFSET ADJUSTMENT

1. Connect the measuring instrument as Fig. 6-1. (SP terminal)
2. Adjust VR201 (VR202) so that the voltage between speaker terminal becomes $80\text{mV} \pm 20\text{mV}$.

Note)

After turning on the power, wait at least 5 minutes before starting the adjustment and complete the adjustment within 10 minutes after turning on the power.

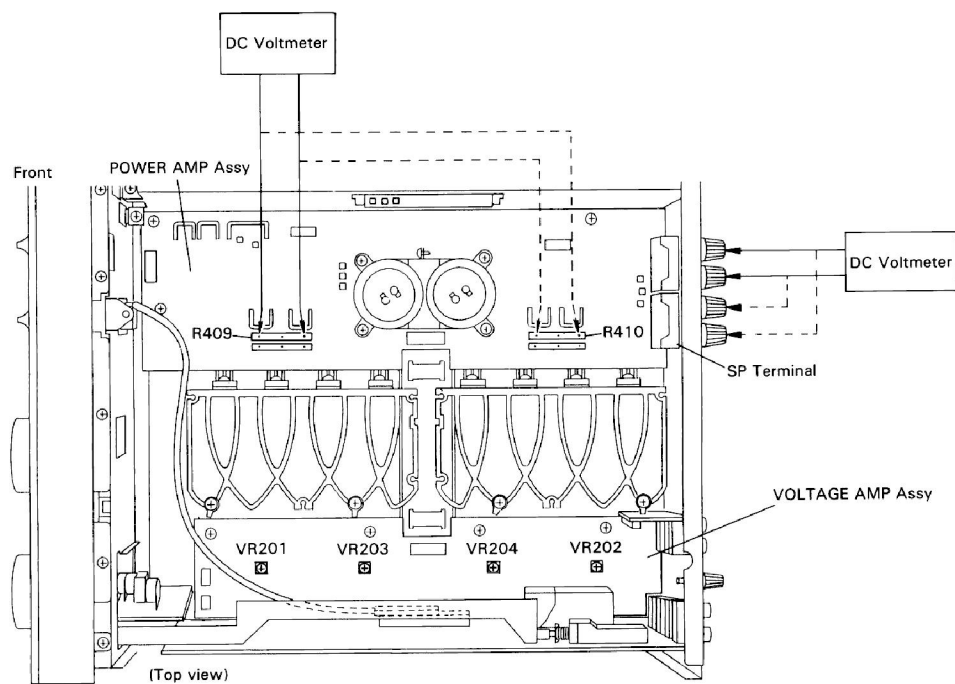

Fig. 6-1 Adjustment Method