

TDE Instruments GmbH  
Gewerbestraße 8  
D-71144 Steinenbronn

Tel.: +49(0)7157 20801  
Fax: +49(0)7157 20813  
Email: info@tde-instruments.de  
Web: www.tde-instruments.de

# TDE Instruments

Version 2012-01

## DPM802

**Bedienungsanleitung**  
**Instructions manual**  
**Instructions d'utilisation**  
**Manual de utilizacion**  
**Istruzioni per l'uso**

Digitalmultimeter für Schalttafeleinbau  
Panel Mount Digital Multimeters  
Multimètres Numériques montés sur bandeau  
Multímetros digitales montados en panel  
Voltamperometri digitali per montaggio su pannelli



Deutsch	02
English	04
Français	06
Español	08
Italiano	10
Beispiele	12
Examples	12
Exemples	12
Ejemplos	12
Esempi	12
RS232 Ausgang	13
RS232 output	13
Sortie RS232	13
Salida RS232	13
Uscita RS232	13

## 1. Beschreibung

3 3/4-stelliges digitales Volt- und Ampèremeter Einbauminstrument mit LCD Anzeige, LED Beleuchtung, zusätzlicher 40 Segment Bargraphanzeige, Low Bat Anzeige und RS232 Schnittstelle. Instrument konfigurierbar für AC oder DC Messung. Dieses Instrument hat eine automatische Bereichsumschaltung bei einem Messbereich von 400mV bis 300V, sowie einen wählbaren Eingangsstrommessbereich von 1µA bis 10A. Min. & max. Werte werden abgespeichert und können abgerufen werden. Die Versorgungsspannung beträgt 5V bis 16V DC.

## 2. Sicherheitshinweise



**Die maximale Spannung, die an den Messeingängen angelegt werden darf ist 300V. INLO (0 V) ist intern an VSS (0 V) angeschlossen.**

### Hinweis:

Die Signalleitungen, die an dieses Gerät angeschlossen werden, dürfen eine Gesamtlänge von 30m nicht überschreiten. Werden Signalleitungen ausserhalb von Gebäuden verlegt, müssen zusätzliche Schutzmassnahmen gegen Surge Störimpulse vorgesehen werden.

## 3. Technische Daten

### Anzeige

Ziffernhöhe 11 mm; 40-Segment Balkenanzeige; Vornullenunterdrückung; Low Bat; x10, x100, DC, AC, µ, m, A, V, MIN, MAX

### Eingangsbereich

± 0,1 mV bis 300 V; ± 0,1 µA bis 10 A

### Genauigkeit

DC: V, µA, mA: ±1%

DC: A: ±3%

AC: 40–650 Hz: V, µA, mA: ±1%; A: ±3%

AC: 650–2700 Hz: ±5%

### Linearität

± 0,1% Vollskala

### Musterrate

1 Sek.

### Eingangsimpedanz

V: 10 MΩ

0 bis 399,9 µA: 500 Ω

400 bis 3999 µA: 50 Ω

0 bis 39,9 mA: 5 Ω

40 bis 399,9 mA: 0,5 Ω

0 bis 10 A: 0,005 Ω

### Anschlüsse

Messeingang: Schraubanschlüsse für Kabel bis zu 1,5 mm<sup>2</sup>

### Versorgung und Steuerung

2 x 5-polig 0,1" Abstand

### Steuerungseingänge

Nur Sink oder Kontakt

### RS232-Ausgang

2400 Baud, 7 Bit, ungerade Parität, 1 Stopbit

### Versorgung

5 bis 16 VDC ± 10%, max. 15 mA

### Hintergrundbeleuchtung

5 bis 8 VDC oder 12 VDC ± 0,5V; max. 110mA

### Installationskategorie (IEC 664)

Überspannungskategorie II

Verunreinigungsgrad 2 (IEC 64)

### Betriebstemperatur

0°C bis +60°C

### Lagertemperatur

-20°C bis +70°C

### Umgebungsschutz

IP50

### Höhe

bis zu 3000 m

### Relative Luftfeuchtigkeit

max. 85% nicht kondensierend

## 4. Leiterplatte

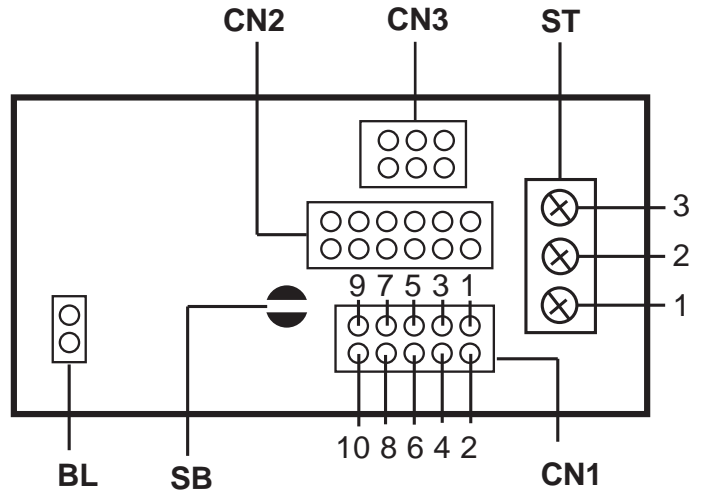

## 5. Konfiguration AC oder DC Messung an Lötbrücke SB

SB offen = DC

SB geschlossen = AC

## 6. Anschluss Versorgung und Steuerung an Stiftleiste CN1

1 VDD 5 VDC bis 16 VDC

2 VSS 0 V

3 Hintergrundbeleuchtung BL+

4 Hintergrundbeleuchtung BL-

5 Gemeinsame Steuerung

6 *nicht angeschlossen*

7 Gemeinsame Steuerung

8 MAX/MIN

9 RS232-Trigger

10 RS232-Ausgang

## 7. Anschluss Versorgung Hintergrundbeleuchtung an CN1

3 5 bis 8 VDC (**Steckbrücke an BL setzen**) oder 12 VDC.

4 0 V

## 8. Anschluss Messeingang an Schraubklemmen ST

1: INHI

±0,1 mV bis 300,0 V

±0,1 µA bis 3999 µA

±0,01 mA bis 399,9 mA

2: INHI

±0,01 A bis 10,0 A

3: INLO

0 V

## 9. Konfiguration Messbereich an CN2 und CN3

$\pm 0.1\text{mV} - 300.0\text{V}$

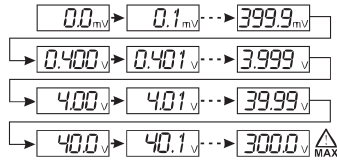
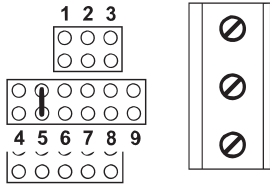

$\pm 0.1\mu\text{A} - 3999\mu\text{A}$

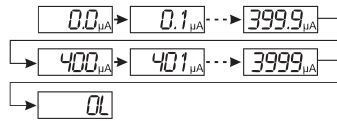
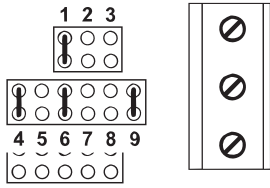

$\pm 0.01\text{mA} - 399\text{mA}$

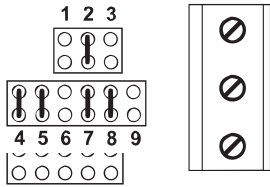

$\pm 0.01\text{A} - 10\text{A}$

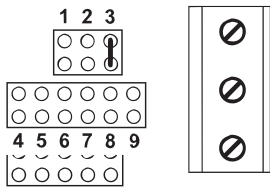

## 10. Steuerungseingänge

Gemeinsame Steuerung (Pin 5 und 7) wird auf  $-3\text{V}$  gehalten. **NUR** an Pin 8 oder 9 anschliessen.

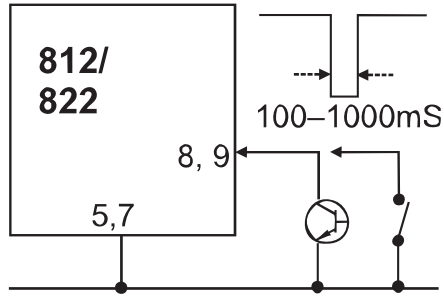

## 11. RS232 Ausgang

Einen Widerstand wie nachstehend gezeigt extern anschliessen.

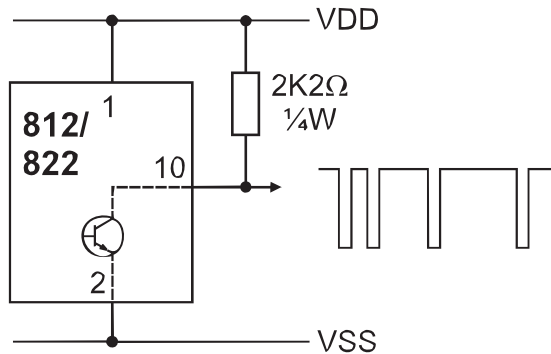

## 12. RS232 Trigger

Einmal an gemeinsame Steuerung anschließen, um den RS232-Datenstrom zu starten. Zum Stoppen erneut an gemeinsame Steuerung anschliessen.

## 13. MAX/MIN-Modus

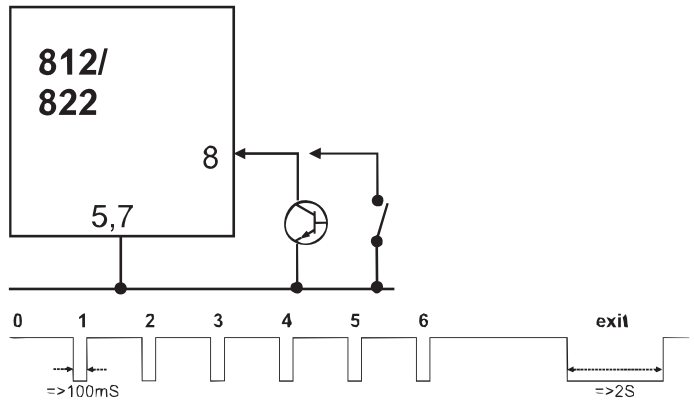

0 aktueller Wert wird angezeigt

1 Zeigt vorherigen Höchstwert an

2 Zeigt vorherigen Mindestwert an

3 Zeigt aktuellen Wert an und beginnt mit der Aufzeichnung neuer Höchst- und Mindestwerte

4 Zeigt neuen Höchstwert an.

5 Zeigt neuen Mindestwert an.

6 Zeigt aktuellen Wert an und beginnt mit der Aufzeichnung neuer Höchst- und Mindestwerte.

usw.

**beenden** Beendet MAX/MIN-Modus und zeigt aktuellen Wert an.

## 1. Introduction

3 3/4 digit volt- and ammeter with a 40 segment bargraph indication, LCD display, LED backlight, low bat indication, and RS232 interface.

The unit has a fully auto ranging voltage input to 300 V and a selectable 4 scale ammeter up to 10A. Powered by 5 VDC up to 16 VDC and annunciators for units on display which include min. and max. functions. Unit can be configured for AC or DC measurement.

## 2. safety instructions



**The maximum voltage allowed for any connection to the PCB is 300V. INLO (0V) is internally connected to VSS (0V)**

### Note:

Any signal cables connected to this device must not exceed 30 metres in length. If signal cables are installed that are routed outside the building, it will be necessary to install additional surge protection devices.

## 3. Specification

### Display

Digits 11 mm; 40-Segment bargraph; Leading zero blanking; Low Bat; x10, x100, DC, AC,  $\mu$ , m, A, V, MIN, MAX

### Input Range

$\pm 0,1$  mV bis 300 V;  $\pm 0,1$   $\mu$ A bis 10 A

### Accuracy

DC: V,  $\mu$ A, mA:  $\pm 1\%$

DC: A:  $\pm 3\%$

AC: 40–650 Hz: V,  $\mu$ A, mA:  $\pm 1\%$ ; A:  $\pm 3\%$

AC: 650–2700 Hz:  $\pm 5\%$

### Linearity

$\pm 0,1\%$  full scale

### Sample Rate

1 sec.

### Input impedance

V: 10 MOhm

0 bis 399,9  $\mu$ A: 500 Ohm

400 bis 3999  $\mu$ A: 50 Ohm

0 bis 39,9 mA: 5 Ohm

40 bis 399,9 mA: 0,5 Ohm

0 bis 10 A: 0,005 Ohm

### Connections

Messeingang: Schraubanschlüsse für Kabel bis zu 1,5 mm<sup>2</sup>

### Power and control

2 x 5-way 0,1" spacing

### Control inputs

Sink or contact only

### RS232-output

2400 baud, 7 bit, odd parity, 1 stop bit

### Supply

5 to 16 VDC  $\pm 10\%$ , max. 15 mA

### Backlight supply

5 to 8 VDC or 12V DC  $\pm 0,5V$ ; max. 110mA

### Installation category (IEC 664)

Overvoltage category II

Pollution degree 2 (IEC 64)

### Operating temperature

0°C to +60°C

### Storage temperature

-20°C bis +70°C

### Environmental protection

IP50

### Altitude

Up to 3000 m

### Relative Humidity

max. 85% non-condensing

## 4. PCB

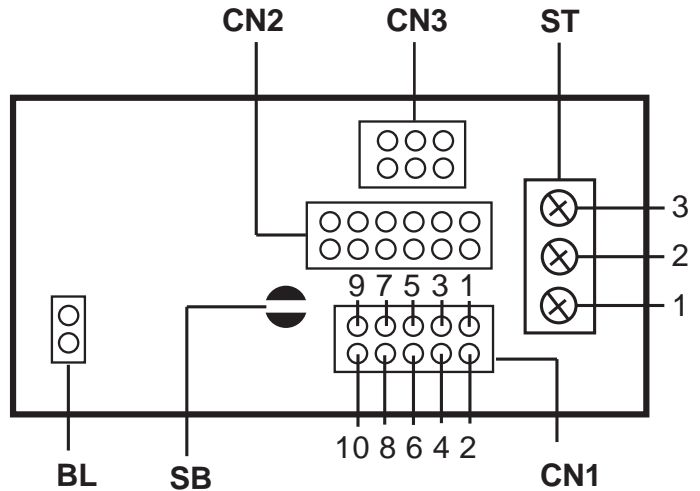

## 5. Configuration AC or DC measuring at solder strap SB

SB open = DC

SB shorted = AC

## 6. Connections Supply and control at socket board at CN1

1 VDD 5 VDC to 16 VDC

2 VSS 0 V

3 Backlight supply BL+

4 Backlight supply BL-

5 Control common

6 *not connected*

7 Control common

8 MAX/MIN

9 RS232-trigger

10 RS232 output

## 7. Connection backlight supply at CN1

3 5 to 8 VDC (set jumper at BL) or 12 VDC.

4 0 V

## 8. Connection Input at ST

1: INHI

$\pm 0,1$  mV to 300,0 V

$\pm 0,1$   $\mu$ A to 3999  $\mu$ A

$\pm 0,01$  mA to 399,9 mA

2: INHI

$\pm 0,01$  A to 10,0 A

3: INLO

0 V

## 9. Configuration measuring range at CN2 and CN3

$\pm 0.1\text{mV}$  - 300.0V

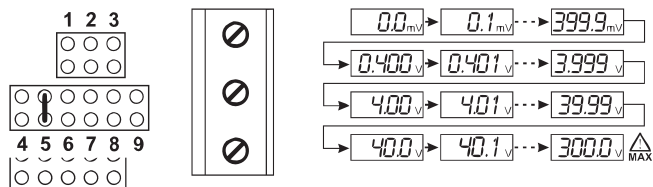

$\pm 0.1\mu\text{A}$  - 3999 $\mu\text{A}$

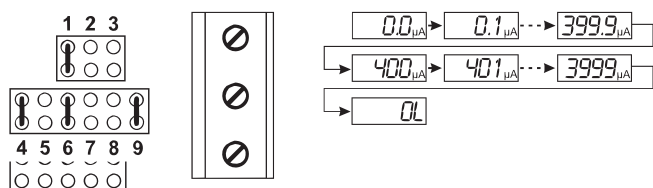

$\pm 0.01\text{mA}$  - 399mA

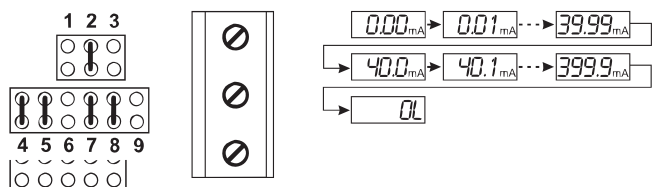

$\pm 0.01\text{A}$  - 10A

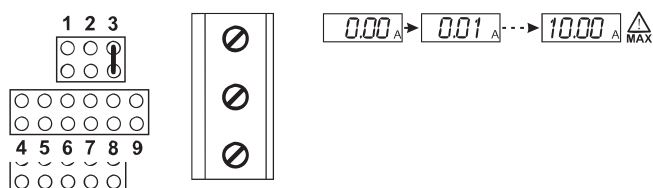

## 10. Control inputs

Control Common (pins 5 and 7) is held at  $-3\text{V}$ . Do **NOT** connect to any pin except pins 8 and 9.

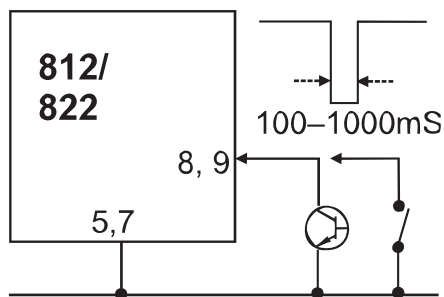

## 11. RS232 output

Connect a resistor externally as shown below.

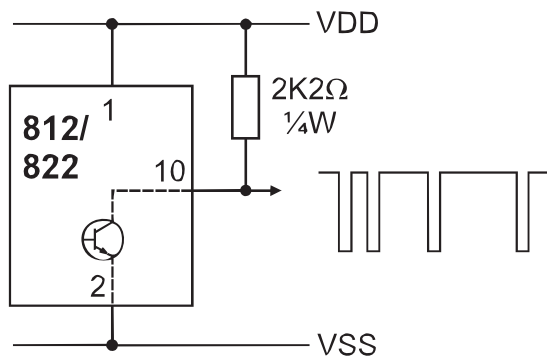

## 12. RS232 trigger

Connect to Control common once to start the RS232 data stream. Connect to Control common again to stop.

## 13. MAX/MIN-Mode

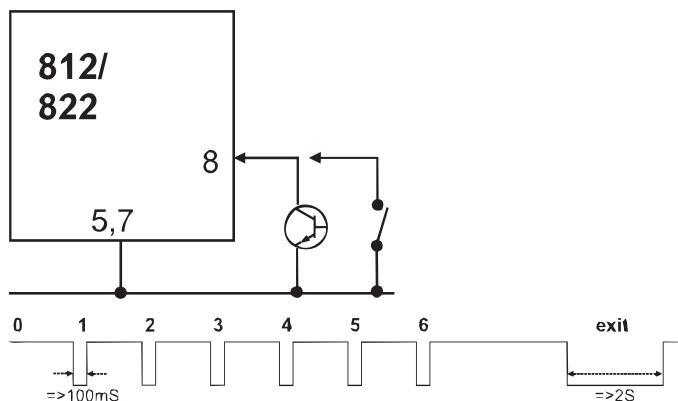

- 0 Displaying current value.
- 1 Displaying current value.
- 2 Displays previous minimum value.
- 3 Displays current value and starts recording new maximum and minimum values.
- 4 Displays new maximum value.
- 5 Displays new maximum value.
- 6 Displays current value and starts recording new maximum and minimum values etc.
- exit Displays current value and starts recording new maximum and minimum values.

## 1. Introduction

Multimètres analogiques/numériques à sélection automatique de gamme, pour montage sur panneau

## 2. Instructions de sécurité



La tension maximale admissible pour tout raccordement sur ce circuit imprimé est de **300V**.  
**INLO (0 V) connectée en interne à VSS (0 V)**

### Remarque:

La longueur de tout câble mesure (signal) raccordé à cet appareil ne doit pas excéder 30 mètres. Si les câbles « mesure » passent à l'extérieur du bâtiment, il est nécessaire d'installer des dispositifs additionnels de protections de surtensions.

## 3. Caractéristiques

### Caractéristiques

Caractères 11 mm; Vumètre à barres, 40 segments;  
Remise à zéro de conduction; Indicateurs : pile faible, x10, x100, CC, CA, -,  $\mu$ , m, A, V, MIN, MAX

### Gamme d'entrée

$\pm 0,1$  mV à 300 V;  $\pm 0,1$   $\mu$ A à 10 A

### Précision

CC: V,  $\mu$ A, mA:  $\pm 1\%$

CC: A:  $\pm 3\%$

CA: 40–650 Hz: V,  $\mu$ A, mA:  $\pm 1\%$ ; A:  $\pm 3\%$

CA: 650–2700 Hz:  $\pm 5\%$

### Linéarité

$\pm 0,1$  % pleine échelle

### Fréquence test

1 s.

### Impédance d'entrée

V: 10 MOhm

0 à 399,9  $\mu$ A : 500 Ohm

400 à 3 999  $\mu$ A : 50 Ohm

0 à 39,9 mA : 5 Ohm

40 à 399,9 mA : 0,5 Ohm

0 à 10 A : 0,005 Ohm

### Raccordements

Entrée : Connexions à vis protège-doigts pour fil jusqu'à 1,5 mm<sup>2</sup>.

### Alimentation et commande :

2 x 5 voies, espacement de 0,1"

### Entrées de commande

Collecteur ou contact uniquement

### Sortie RS232

2 400 bauds, 7 bits, parité impaire, 1 bit d'arrêt

### Alimentation

5 à 16 VCC  $\pm 10\%$ , 15 mA max

### Rétroéclairage

5 à 8 VCC / 12 VCC  $\pm 0,5$ V sélectionnable, 110 mA max.

### Catégorie d'installation (IEC664)

Catégorie surtension II

Degré de pollution 2 (IEC 64)

### Température de fonctionnement

0°C à +60°C

### Température de stockage

-20°C à +70°C

### Protection environnementale

IP50

### Altitude

usqu'à 3 000 m

### Relative Humidity

85 % max., sans condensation

## 4. Cartes de circuits imprimés

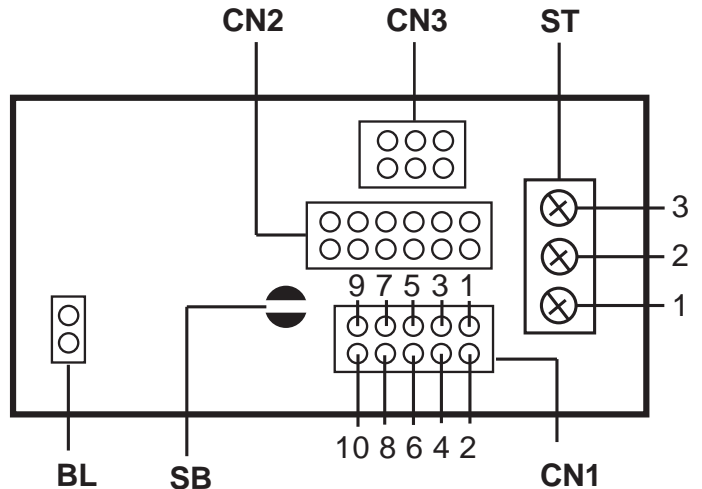

## 5. Configuration AC ou DC mesure à SB

SB ouvert = CC

SB dérivés = CA

## 6. Raccordements Alimentation et commande à CN1

1 VDD 5 V CC à 16 V CC

2 VSS 0 V

3 Rétroéclairage BL+

4 Rétroéclairage BL-

5 Commande, commune

6 non connectée

7 Commande, commune

8 MAX/MIN

9 Déclencheur RS232

10 Sortie RS232

## 7. Raccordements Alimentation rétroéclairage à CN1

3 5 à 8 VCC (placer pont à BL) ou 12 VCC.

4 0 V

## 8. Raccordements Entrée à ST

1: INHI

$\pm 0,1$  mV à 300,0 V

$\pm 0,1$   $\mu$ A à 3999  $\mu$ A

$\pm 0,01$  mA à 399,9 mA

2: INHI

$\pm 0,01$  A à 10,0 A

3: INLO

0 V

## 9. Configuration Gamme d'entrée CN2 et CN3

$\pm 0.1\text{mV} - 300.0\text{V}$

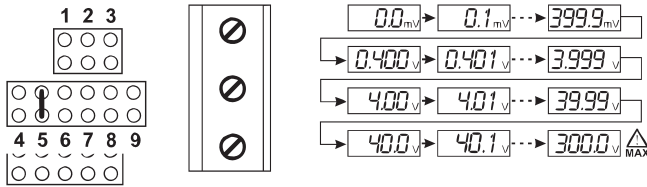

$\pm 0.1\mu\text{A} - 3999\mu\text{A}$

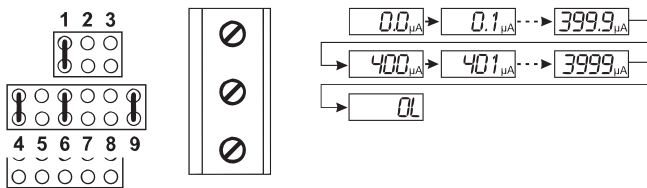

$\pm 0.01\text{mA} - 399\text{mA}$

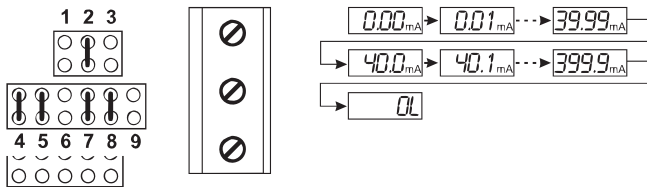

$\pm 0.01\text{A} - 10\text{A}$

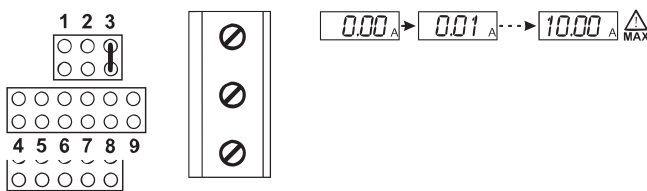

## 10. Entrées de commande

Commande commune (broches 5 et 7) à  $-3\text{V}$ . **Ne PAS** connecter à quelque broche que ce soit, sauf aux broches 8 et 9.

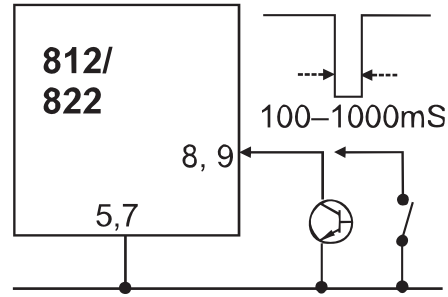

## 11. Sortie RS232

Brancher une résistance en externe, comme indiqué ci-dessous.

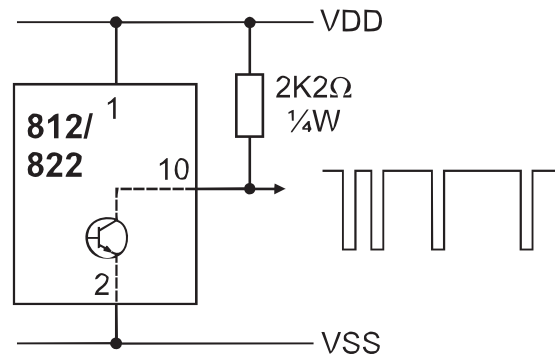

## 12. Déclencheur RS232

Brancher à la commande commune une fois, pour lancer le flux de données RS232. Brancher de nouveau à la commande commune pour arrêter.

## 13. Mode MAX/MIN

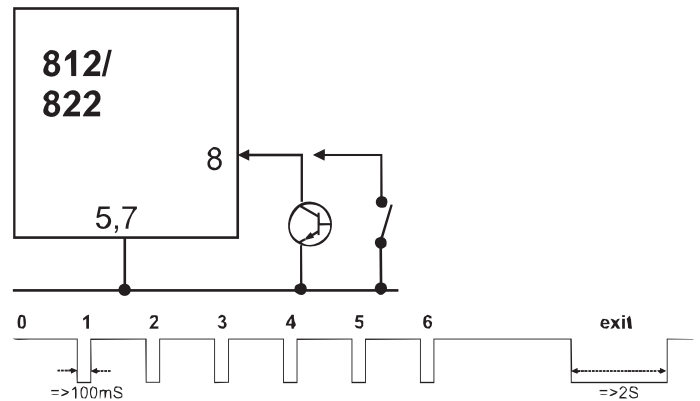

0 Affichage de la valeur actuelle

1 Affichage de la valeur maximale précédente

2 Affichage de la valeur minimale précédente

3 Affichage de la valeur actuelle et enregistrement des nouvelles valeurs maximales et minimales

4 Affichage de la nouvelle valeur maximale.

5 Affichage de la nouvelle valeur minimale.

6 Affichage de la valeur actuelle et enregistrement des nouvelles valeurs maximales et minimales. etc

**Quitter** Quitte le mode MAX/MIN et affiche la valeur actuelle.

## 1. Introducción

Multímetros analógicos/digitales con autocalibración para montaje en panel

## 2. Observaciones de seguridad



El voltaje máximo permitido para cualquier conexión al circuito impreso es 300V. INLO (0 V) va conectado internamente a VSS (0 V)

### Nota:

Cualquier cable de señal conectado a esta unidad no debe de exceder de 30 metros. Si se instalan cables de señal que sean llevados fuera del edificio, será necesario instalar unidades adicionales de protección de onda.

## 3. Especificación

### Pantalla

61 mm x 18 mm; 4 caracteres de 11 mm; Gráfico de barras de 40 segmentos; Se borran los ceros a la izquierda; Anunciadores: batería baja, x10, x100, CC, CA, -,  $\mu$ , m, A, V, MÍN., MÁX

### Rango de entrada

0,1 mV a 300 V

$\pm 0,1 \mu\text{A}$  a 10 A

### Precisión

( $\pm 1$  del dígito menos significativo)

CC: V,  $\mu\text{A}$ , mA:  $\pm 1\%$

CC: A:  $\pm 3\%$

CA: 40-650 Hz: como anterior

CA: 650-2700 Hz:  $\pm 5\%$

### Linealidad

$\pm 0,1\%$  escala completa

### Velocidad de muestreo

1 seg.

### Impedancia de entrada

V: 10 M $\Omega$

0 a 399,9  $\mu\text{A}$ : 500  $\Omega$

400 a 3999  $\mu\text{A}$ : 50  $\Omega$

0 a 39,9 mA: 5  $\Omega$

40 a 399,9 mA: 0,5  $\Omega$

0 a 10 A: 0,005  $\Omega$

### Conexiones

Entrada: Conexiones tornillo a prueba de dedos para cables de hasta 1,5 mm<sup>2</sup>.

Alimentación y control: 2 x 5 vías 0,1 pulg. paso

### Entradas de control

Sólo absorción o contacto

### Salida RS232

2.400 baudios, 7 bits, paridad impar, 1 bit de parada

### Alimentación

5 a 16 VCC  $\pm 10\%$ , 15 mA máx

### Luz de fondo

5 a 8 VCC / 12 VCC  $\pm 0,5\text{V}$  seleccionable, 110 mA máx.

### Categoría de instalación (IEC664)

Categoría II de sobrevoltaje

Grado de contaminación 2 (IEC64)

### Temperatura de Funcionamiento

0° C a 60° C

### Temperatura de almacenaje

-20° C a 70° C

### Protección ambiental

IP50

### Altitud

Hasta 3.000 m

### Humedad relativa

85% máx. sin condensado

## 4. Circuito impreso

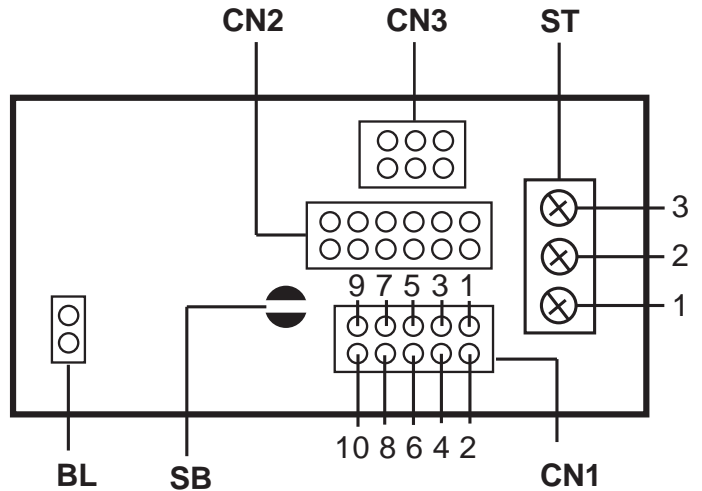

## 5. Configuración medición CC ó CA a SB

SB abierto = CC

SB acortados = CA

## 6. Conexiones alimentación y control a CN1

1 VDD 5 V CC a 16 V CC

2 VSS 0 V

3 Luz de fondo BL+

4 Luz de fondo BL-

5 Control común

6 no conectado

7 Control común

8 MÁX./MÍN. (ver la página 9)

9 Disparo RS232

10 Salida RS232

## 7. Conexiones alimentación luz de fondo a CN1

3 5 a 8 VCC (usar jumper a BL) ó 12 VCC.

4 0 V

## 8. Conexiones entrada a ST

1: INHI

$\pm 0,1 \text{ mV}$  a 300,0 V

$\pm 0,1 \mu\text{A}$  a 3999  $\mu\text{A}$

$\pm 0,01 \text{ mA}$  a 399,9 mA

2: INHI

$\pm 0,01 \text{ A}$  a 10,0 A

3: INLO

0 V



## 9. Configuración campo de medición a CN2 y CN3

±0.1mV - 300.0V

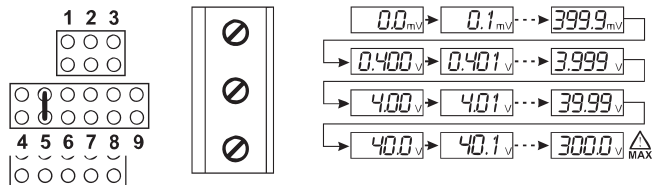

±0.1µA - 3999µA

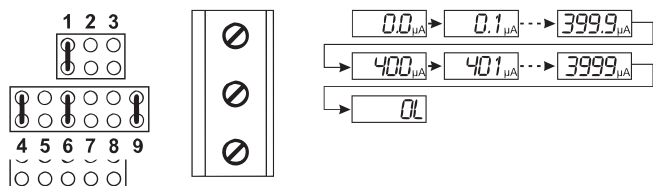

±0.01mA - 399mA

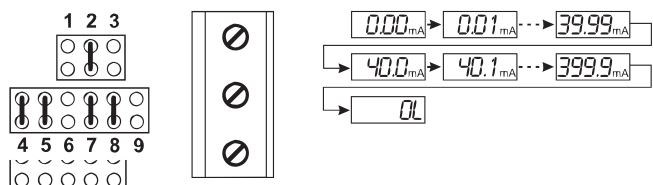

±0.01A - 10A

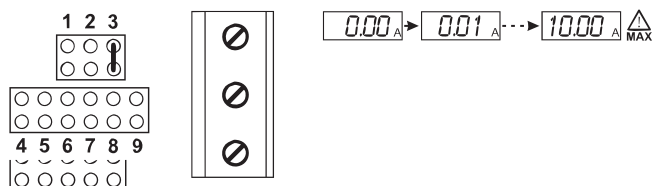

## 10. Entradas de control

Control común (clavijas 5 y 7) mantenido a -3V. **NO** conectar a ninguna clavija, excepto la clavijas 8 y 9.

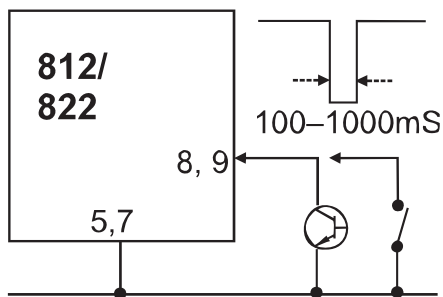

## 11. Salida RS232

Conectar una resistencia externa como se indica a continuación.

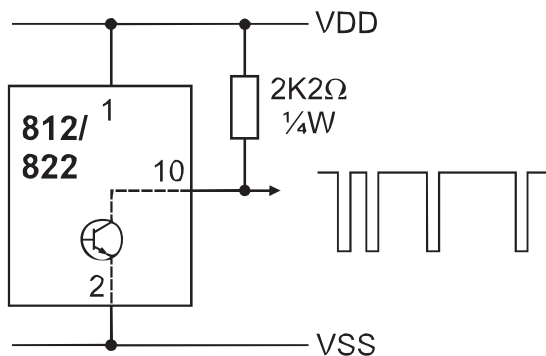

## 12. Disparo RS232

Conectar a control común una vez para comenzar el tren de datos RS232. Conectar a control común otra vez para detener.

## 13. Modo MÁX./MÍN.

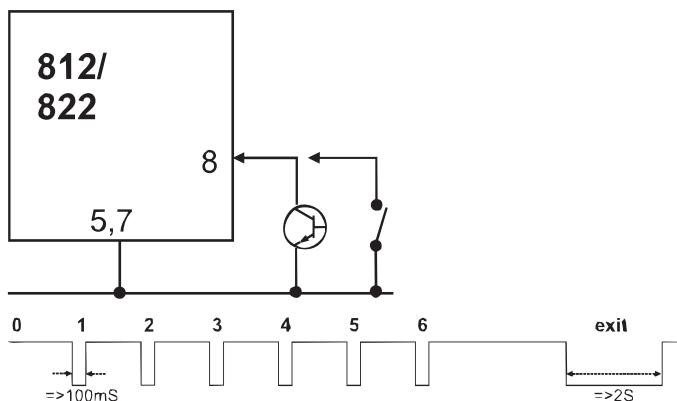

0 Indica el valor actual.

1 Indica el valor máximo anterior.

2 Indica el valor mínimo anterior.

3 Muestra el valor actual y empieza a registrar los nuevos valores máximos y mínimos.

4 Indica el nuevo valor máximo.

5 Indica el nuevo valor mínimo.

6 Muestra el valor actual y empieza a registrar los nuevos valores máximos y mínimos.

etc.

**salir** Sale del modo MÁX./MÍN. e indica el valor actual.

## 1. Introduzione

Multimetri digitali/analogici con montaggio a pannello autoranging

## 2. Istruzioni di sicurezza



La tensione massima consentita per una connessione su PCB è di 300V.  
INLO (0 V) è collegato internamente a VSS (0 V)

### Nota:

Ogni cavo di segnale collegato a questo dispositivo non può essere più lungo di 30 metri. Se i cavi di segnale sono installati su un percorso esterno all'edificio, è necessario installare dispositivi di protezione di rete aggiuntivi.

## 3. Specifiche

### Display

61 mm x 18 mm; Altezza cifre 4 x 11 mm; Grafico a barre con 40 segmenti; Zeri non significativi soppressi; Annunciatori: livello batteria basso, x10, x100, CC, CA, -,  $\mu$ , m, A, V, MIN, MAX

### Gamme di ingresso

da  $\pm 0,1$  mV a 300 V

da  $\pm 0,1$   $\mu$ A a 10A

### Accuratezza

( $\pm 1$  la cifra significativa minima)

CC: V,  $\mu$ A, mA:  $\pm 1\%$

CC: A:  $\pm 3\%$

CA: 40-650 Hz: come sopra

CA: 650-2700 Hz:  $\pm 5\%$

### Linearità

$\pm 0,1\%$  della scala completa

### Frequenza di campionamento

1 sec.

### Impedenza d'ingresso

V: 10 MOhm

da 0 a 399,9  $\mu$ A: 500 Ohm

da 400 a 3999  $\mu$ A: 50 Ohm

da 0 a 39,9 mA: 5 Ohm

da 40 a 399,9 mA: 0.5 Ohm

da 0 a 10 A: 0.005 Ohm

### Collegamenti

Ingresso: collegamenti con viti di protezione per cavi fino a 1,5 mm<sup>2</sup>

Alimentazione e controllo: 2 x 5 vie, spaziatura 0,1"

### Ingressi di controllo

Solo contatto o sink

### Uscita RS232

2400 baud, 7 bit, parità dispari, 1 bit di stop

### Alimentazione

da 5 a 16 VCC  $\pm 10\%$ , 15mA max

### Retroilluminazione

da 5 a 8 VCC/12 VCC  $\pm 0.5V$  selezionabile, 110 mA max

### Categoria di installazione (IEC664)

Categoria di sovratensione II

Grado di inquinamento 2 (IEC 64)

### Temperatura di funzionamento

da 0°C a +60°C

### Temperatura di immagazzinaggio

-da 20°C a +70°C

### Protezione ambientale

IP50

### Altitudine

Fino a 3000 m

### Umidità relativa

85% max (senza condensa)

## 4. PCB

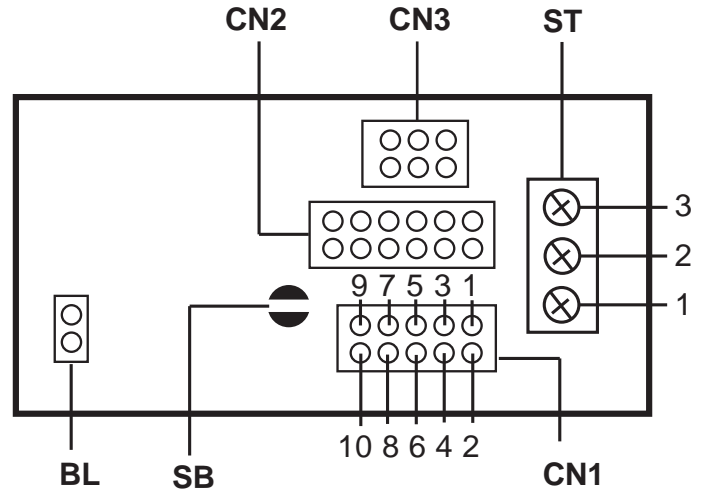

## 5. Configurazione misurazione CC o CA a SB

SB aperto = DC

SB cortocircuitato = AC

## 6. Collegamenti alimentazione e controllo a CN1

1 VDD da 5 VCC a 16 VCC

2 VSS 0 V

3 Retroilluminazione BL+

4 Retroilluminazione BL-

5 Controllo comune

6 Non collegato

7 Controllo comune

8 MAX/MIN (vedere pagina 10)

9 Trigger RS232

10 Uscita RS232

## 7. Collegamenti alimentazione retroilluminazione a CN1

3 da 5 a 8 VCC (Usare jumper a BL) a 12 VCC.

4 0 V

## 8. Collegamenti ingresso Misurazione a ST

1: INHI

$\pm 0,1$  mV a 300,0 V

$\pm 0,1$   $\mu$ A a 3999  $\mu$ A

$\pm 0,01$  mA a 399,9 mA

2: INHI

$\pm 0,01$  A a 10,0 A

3: INLO

0 V

## 9. Configurazione gamme di misurazione a CN2 e CN3

$\pm 0.1\text{mV} - 300.0\text{V}$

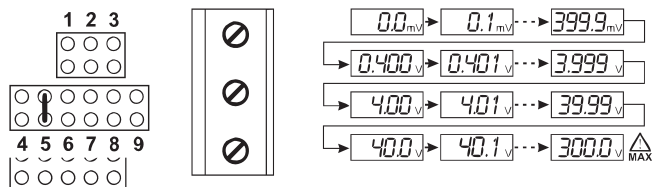

$\pm 0.1\mu\text{A} - 3999\mu\text{A}$

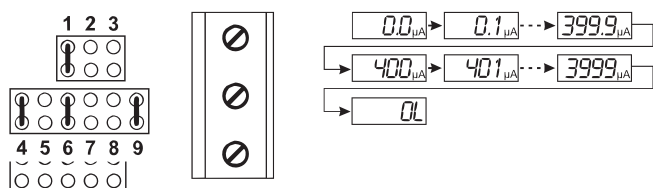

$\pm 0.01\text{mA} - 399\text{mA}$

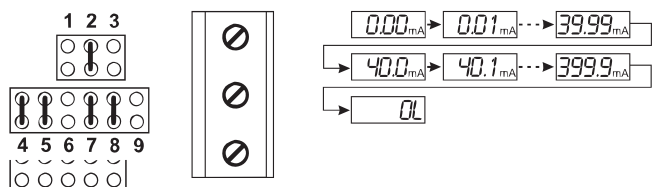

$\pm 0.01\text{A} - 10\text{A}$

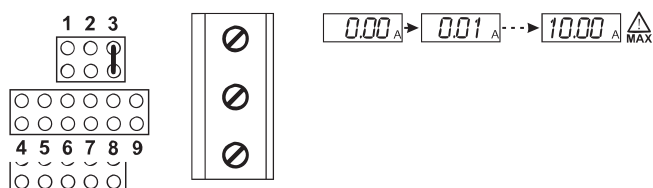

## 10. Ingressi di controllo

Il controllo comune (pin 5 e 7) viene mantenuto a -3 V. Collegare **SOLO** ai pin 8 e 9.

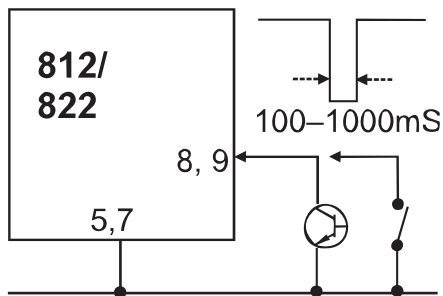

## 11. Uscita RS232

Collegare un resistore esterno, come mostrato di seguito.

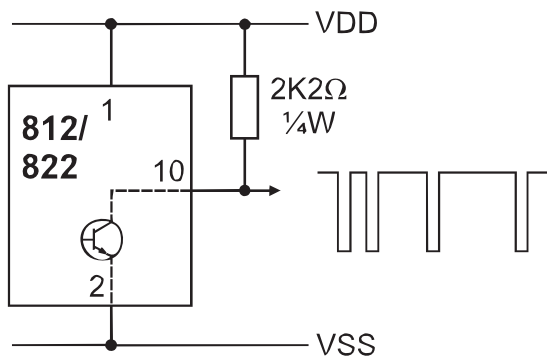

## 12. Trigger RS232

Collegare al controllo comune una volta avviato il flusso di dati RS232. Collegare nuovamente al controllo comune per arrestare.

## 13. Modalità MAX/MIN

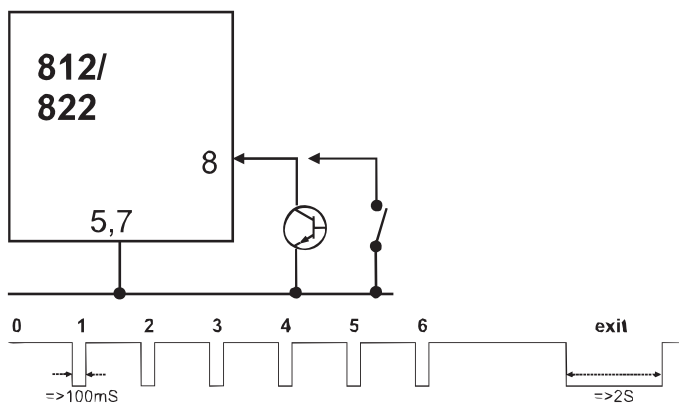

- 0 Visualizza il valore corrente.
- 1 Visualizza il valore massimo precedente.
- 2 Visualizza il valore minimo precedente.
- 3 Visualizza il valore corrente e avvia la registrazione dei nuovi valori massimo e minimo.
- 4 Visualizza il nuovo valore massimo.
- 5 Visualizza il nuovo valore minimo.
- 6 Visualizza il valore corrente e avvia la registrazione dei nuovi valori massimo e minimo. ecc.
- exit Esce dalla modalità MAX/MIN e visualizza il valore corrente.

Beispiele  
 Examples  
 Exemples  
 Ejemplos  
 Esempi

DC

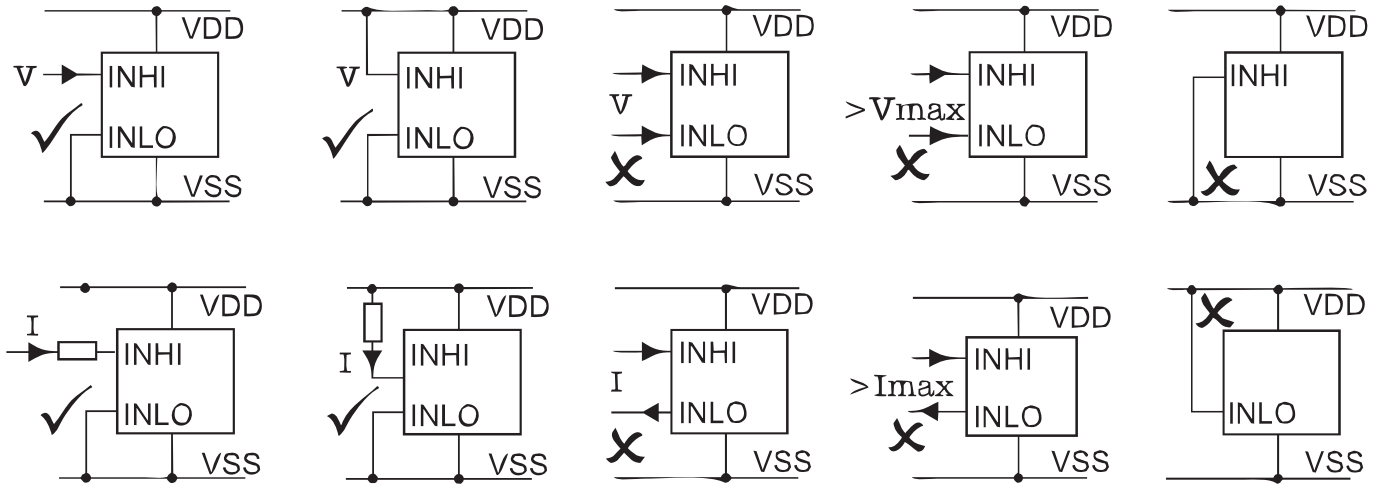

AC

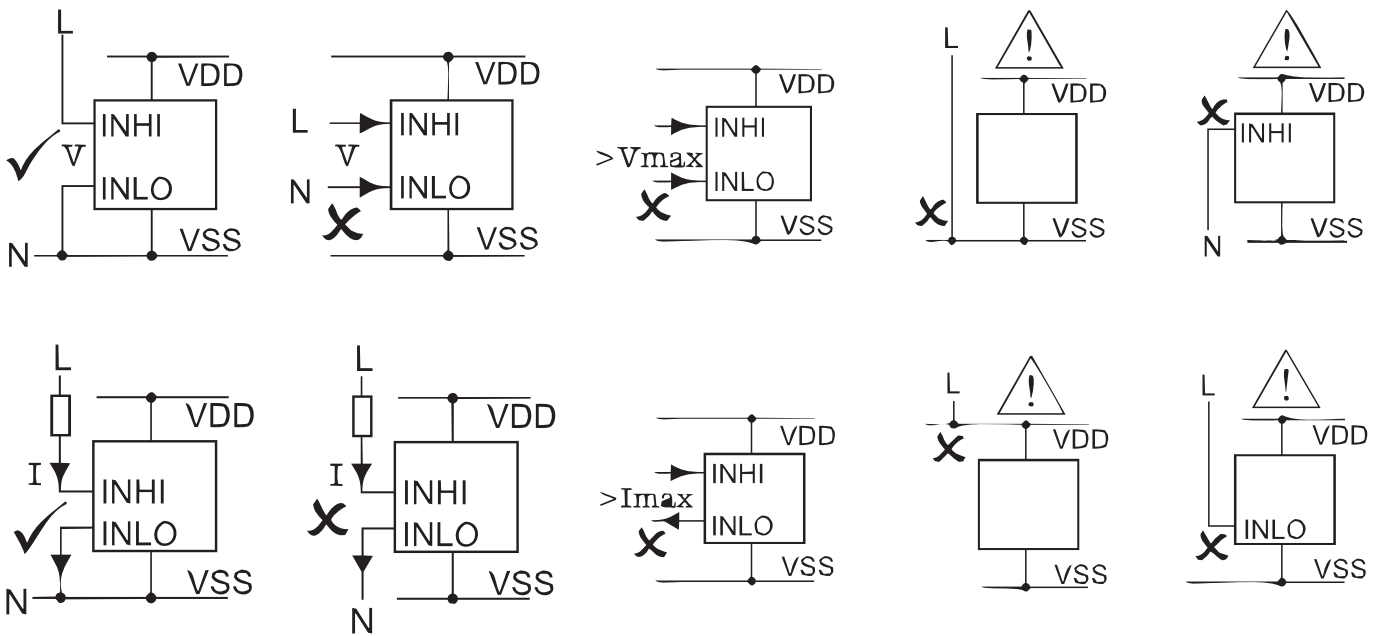

## 1. Serial Data output

The serial data is sent to the data output pin (pin 10) twice every A/D conversion cycle. The data format complies with JIS 7BIT transmission code with a baud rate of 2400. The host can use the RS232 interface to read the data. A single data packet allows a start bit (always 0), 7 data bits, an odd parity check bit, and a stop bit (always 1). The high and low voltage levels correspond to +V and -3V respectively. The serial output remains at 1 (high) when it is inactive. Hence the start bit (0) could be used as the triggering signal to begin the reading process. The following figure shows the data format of a single packet. The LSB is sent first and the MSB is sent last.



One data block consists of 11 packets, or 110 bits. The following figure shows the format of a data block. The range packet indicates the full scale range of the meter. Digit 3 through to digit 0 represent the digits on the meters display. The function packet indicates the measurement mode of the meter. Status, option 1, and option 2 give the status of the meter. CR and LF are delimiters used to separate the blocks.

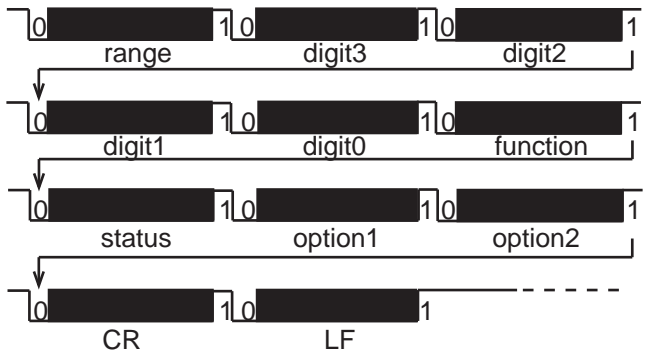

The meter always outputs the current input value to the serial port regardless of whether the hold function has been activated or not. Each block is repeated twice in one conversion cycle. The detailed data format of each packet is listed below.

## 2. Function

This packet indicates the measurement mode of the meter. The following table summarises the transmitted code for each mode. Note that the encoding of this packet is different to the encoding of the FC1 to FC4 switch.

Code	Measurement Mode
0111011	Voltage
0111101	µA Current
0111001	mA Current
0111111	A Current
0111110	ADP0
0111100	ADP1
0111000	ADP2
0111010	ADP3

## 3. Range

This packet indicates the full scale range of the meter. When the meter is in current mode (A) this packet is always 0110000 since the full scale range in this mode is fixed. The following table shows the codes for each range.

Code	V	mA	µA
0110000	400.0 mV	40.00 mV	400.0 µA
0110001	4.000 V	400.0 mA	4000 µA
0110010	40.00 V		
0110011	400.0 V		
0110100	4000 V		
0110101			

## 4. Digit 3 to digit 0

Digit 3 is the most significant digit on the LCD panel, and the digit 0 is the least significant digit. When the LCD panel shows OL the serial port outputs 4000.

Digit	Code
0	110000
1	110001
2	110010
3	110011
4	110100
5	110101
6	110110
7	110111
8	111000
9	111001

## 5. Status

The format of this packet is shown below. (The judge field is not applicable to these units, but will be present in the data field- it should be disregarded). The sign field indicates whether the minus sign on the LCD is ON or OFF. The Batt field indicates if the battery low condition is true. OL indicates input overflow.

0	1	1	Judge	Sign	BATT	OL
Bit 6	Bit 5	Bit 4	Bit 3	Bit 2	Bit 1	Bit 0

## 6. Option 1

This packet contains information on special measurement modes. The format of this packet is shown below. The three none constant fields are set to "1" when the meter operates in the corresponding special modes, max and min. Bit 0 (VAHZ) is not applicable.

0	1	1	Pmax	Pmin	0	VAHZ
Bit 6	Bit 5	Bit 4	Bit 3	Bit 2	Bit 1	Bit 0

## 7. Option 2

This packet contains information on the operating mode of the meter. The format of this packet is shown below. The DC field indicates that the meter operates in DC mode, measuring voltage or current. The AC mode indicates that the meter operates in AC mode, measuring voltage or current. The APO field is not applicable.

<b>0</b>	<b>1</b>	<b>1</b>	<b>DC</b>	<b>AC</b>	<b>AUTO</b>	<b>APO</b>
Bit 6	Bit 5	Bit 4	Bit 3	Bit 2	Bit 1	Bit 0

## 8. CR

Carriage Return. The transmitted code is 0001101

## 9. LF

Line Feed. The transmitted code is 0001010

Abmessungen  
 Dimensions  
 Dimensiones  
 Dimensioni

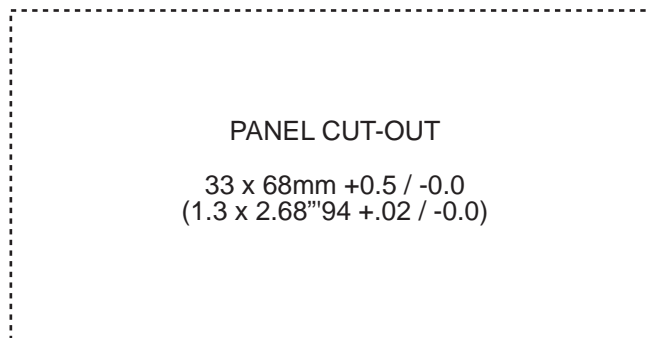
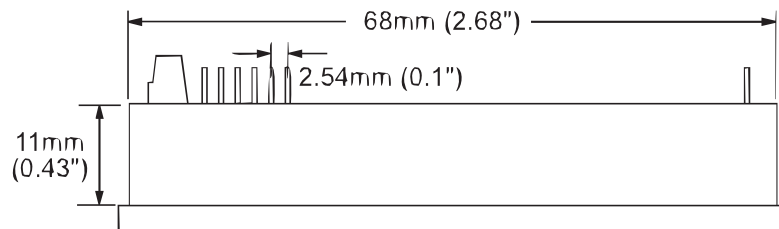
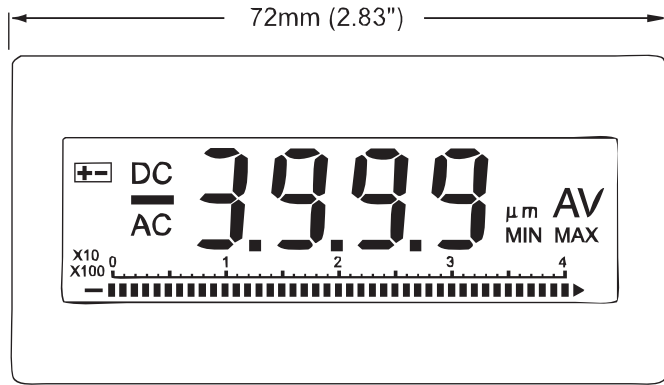
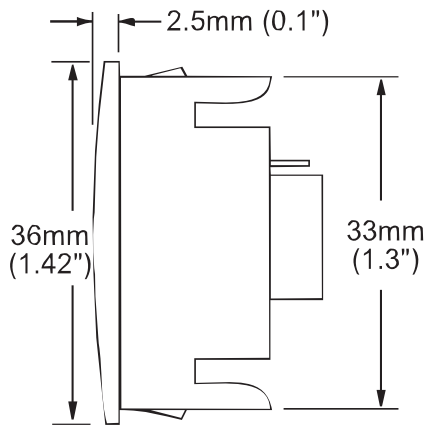

# **TDE** Instruments

**TDE Instruments GmbH  
Gewerbestraße 8  
D-71144 Steinenbronn**

**Tel.: +49(0)7157 20801  
Fax: +49(0)7157 20813  
Email: [info@tde-instruments.de](mailto:info@tde-instruments.de)  
Web: [www.tde-instruments.de](http://www.tde-instruments.de)**

---