

The home of the turntable

THE VINYL ENGINE®

For more turntable manuals and setup information
please visit www.vinylengine.com

NAD

5120

**SEMI-AUTOMATIC
BELT-DRIVE
TURNTABLE**

**INSTRUCTIONS
FOR INSTALLATION
AND OPERATION**

- | | |
|----------------------|-------------------------|
| 1. Transit screw | 10. Main platter disc |
| 2. Dust cover | 11. Rubber platter mat |
| 3. Hinges | 12. Center hole adapter |
| 6. Speed change knob | 13. Stop/Play control |
| 7. Drive belt | 14. Pilot light |
| 8. Motor pulley | 15. Tonearm |
| 9. Sub-platter | |

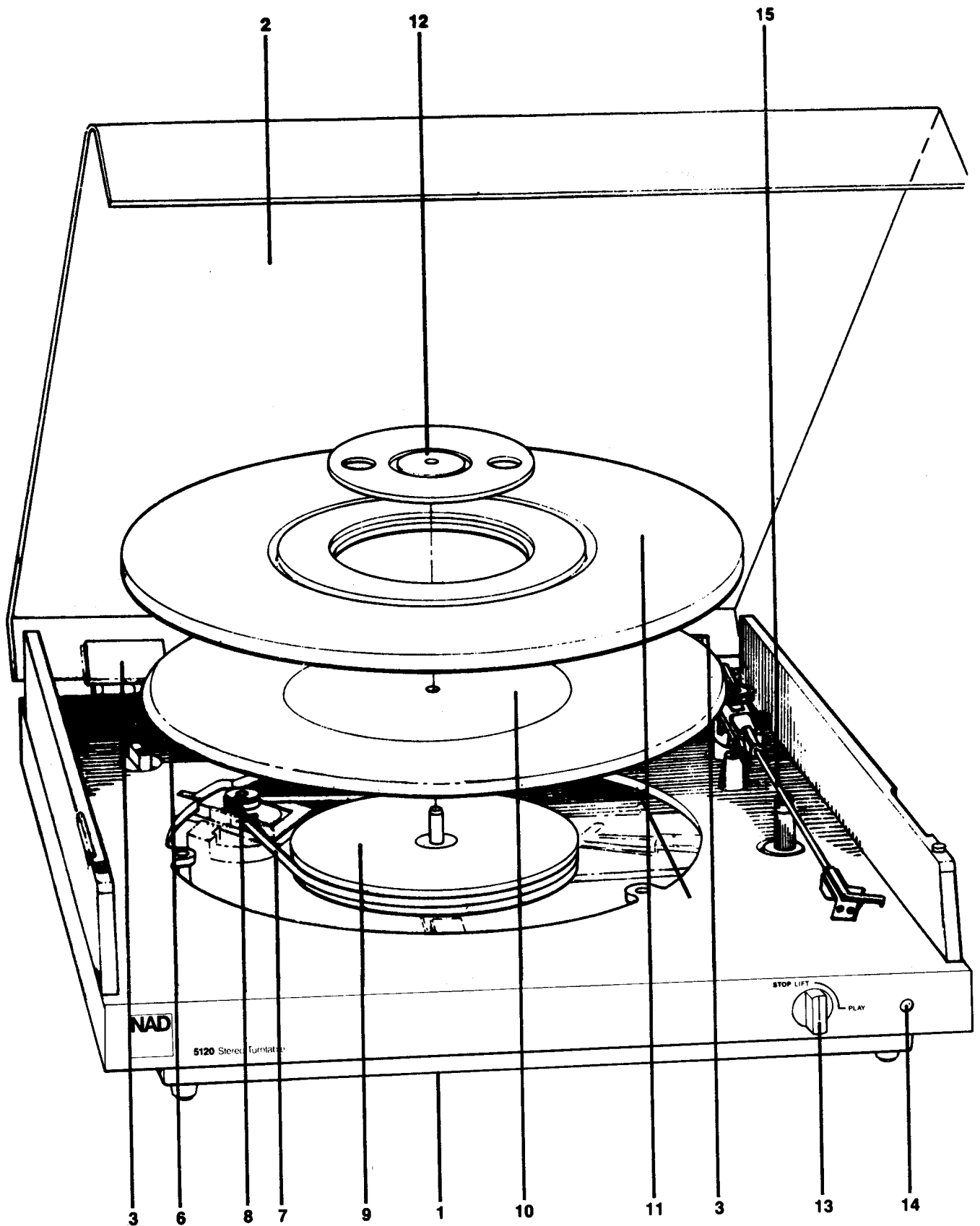

- 1. Transit screw
- 2. Dust cover
- 3. Hinges
- 4. AC power cord
- 5. Signal cables
- 11. Rubber platter mat
- 15. Tonearm

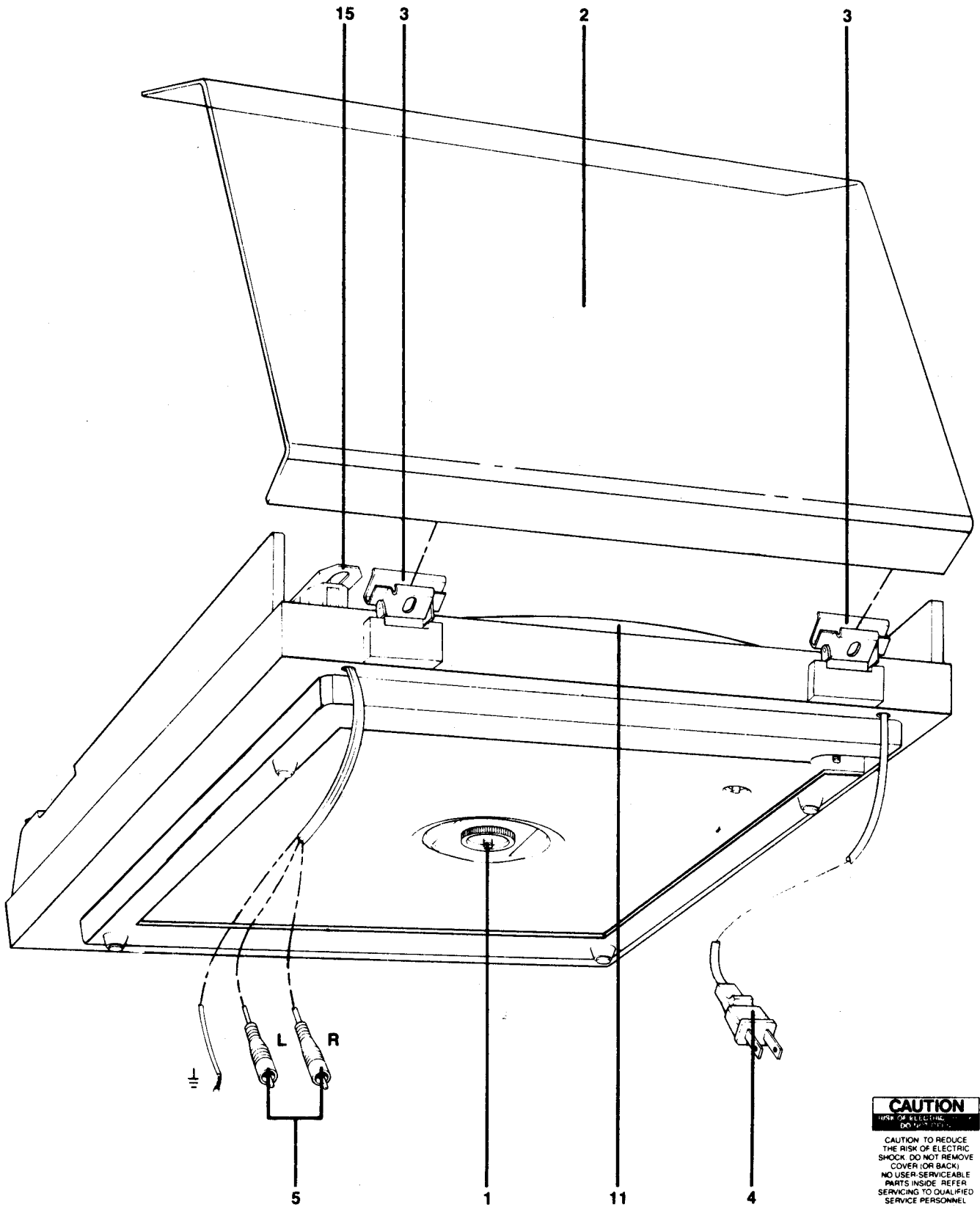

CAUTION
 RISK OF ELECTRIC SHOCK
 DO NOT OPEN

CAUTION TO REDUCE THE RISK OF ELECTRIC SHOCK, DO NOT REMOVE COVER (OR BACK). NO USER-SERVICEABLE PARTS INSIDE. REFER SERVICING TO QUALIFIED SERVICE PERSONNEL.

- 15. Tonearm
- 16. Pivot assembly
- 17. Tonearm socket
- 18. DVA damping rod
- 19. DVA damping fluid
- 20. Damping fluid chamber

- 21. Damping scale
- 22. Tracking force wheel
- 23. Tracking force dial
- 24. Spring washer
- 25. DVA frequency setting screw
- 26. DVA spring

- 27. Counterweight
- 28. DVA frequency scale
- 29. Tonearm rest post
- 30. Cueing height screw
- 31. Cueing post
- 32. Antiskating control

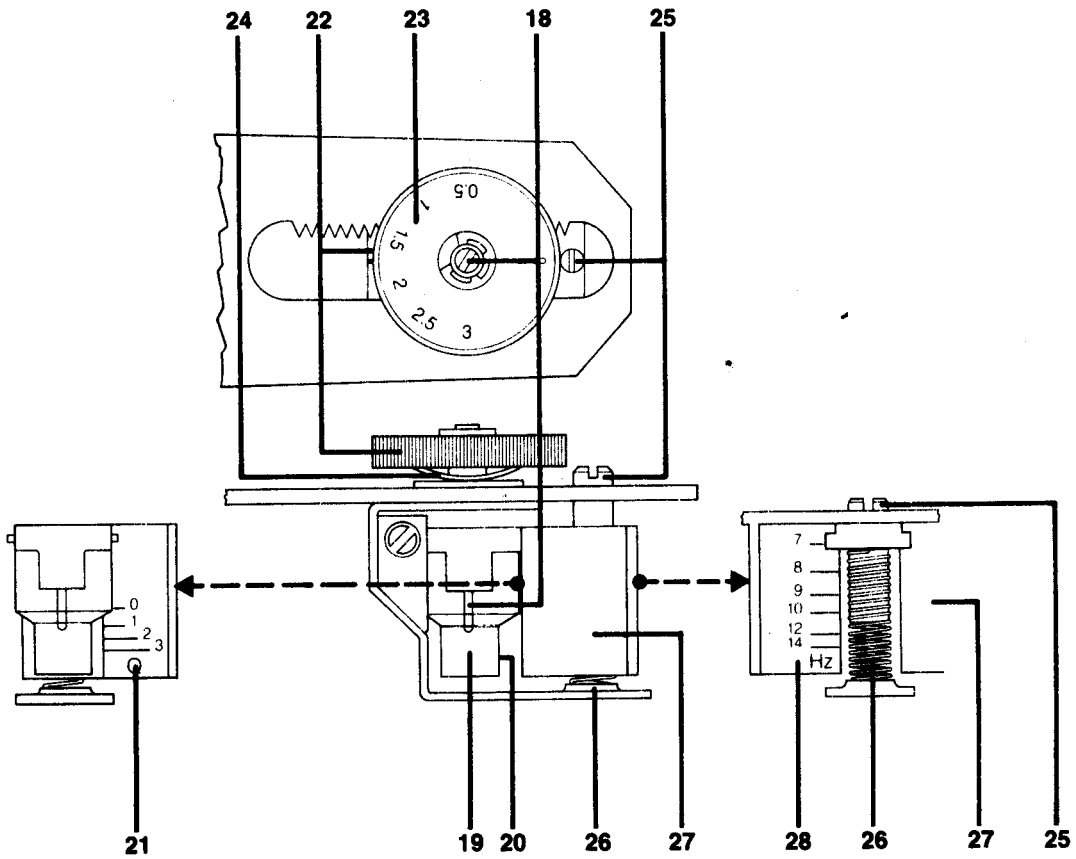
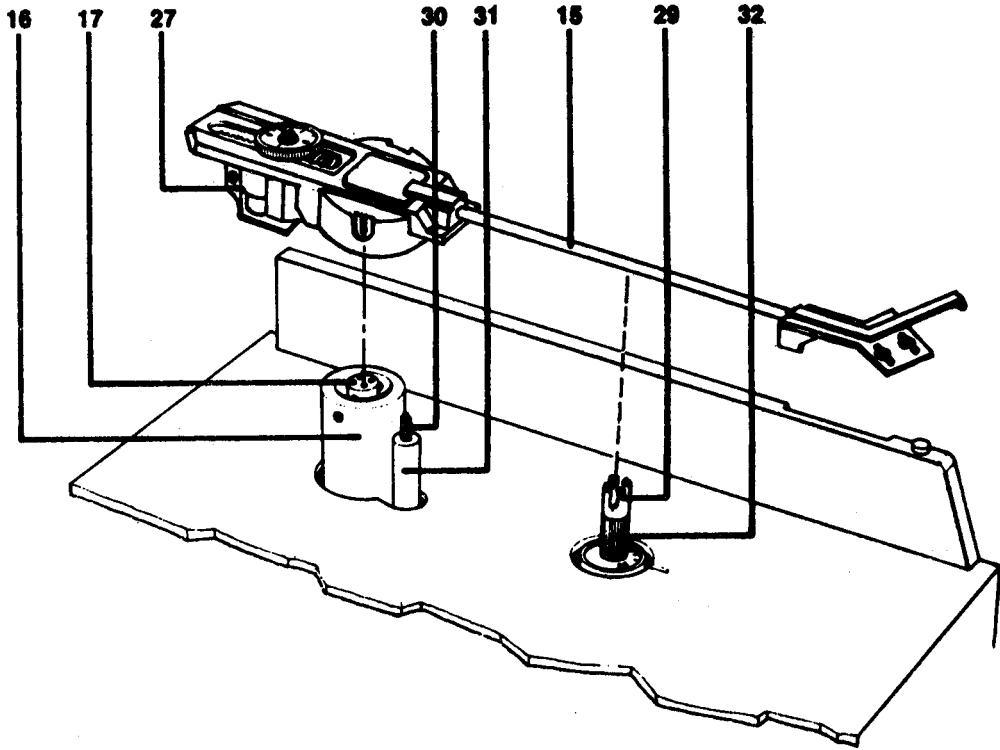

NOTE: In the following instructions, numbers in square brackets identify the various parts of the turntable, as shown in the illustrations.

UNPACKING

1. Lift the entire turntable system out of the carton, together with the protective styrofoam blocks.
2. Slide the styrofoam blocks off the front and rear of the turntable system.
3. Remove the turntable system from the protective plastic wrapper that it is enclosed in.
4. Place the turntable on a clean, level working surface such as a large table.
5. Lift off the plastic dust cover [2] and set it aside.
6. The turntable contains a large sculptured styrofoam insert containing the platter and tonearm. Carefully lift this insert *straight up* away from the turntable and place it on your working surface beside the turntable base.
7. Then remove the platter assembly from its plastic wrapper. Note that it consists of three parts: the rubber mat [11], metal platter disc [10], and center-hole adapter [12].
8. Remove the turntable/counterweight assembly from its place in the styrofoam insert.
9. Find the small accessories bag containing a small screwdriver shaft; this will be used for adjusting the damping screw in the tonearm.
10. Proceed to the ASSEMBLY instructions below.
11. Do not discard any packing materials until after you have completed setting up the turntable and all parts are accounted for. Then we suggest that you reinstall the styrofoam moldings in the carton, tape the carton closed, and store it in a safe place so that it can be re-used in case the turntable must be shipped in the future.
12. **RE-PACKING NOTE:** If it becomes necessary to ship the turntable at some future date the following requirements are essential, regardless of whether you use the supplied packing materials or not. (1) Lift off the platter assembly. It must be packed separately in order to avoid damaging the platter bearings. (2) In the tonearm, turn the damping rod [18] counterclockwise until the lower end of the screw is above the "0" mark on the damping scale [21]; this is necessary in order to seal the damping chamber and prevent leakage of the damping oil. (3) If you are re-using the original carton provided with the 5120, unplug the tonearm and place it in the space provided in the styrofoam insert. If you are using another carton, you may leave the tonearm in its socket, taped securely to its rest post so that it cannot move during shipment. (4) Turn the nut on the transit screw fully clockwise as viewed from below, drawing down the floating chassis until it rests firmly on the bottom of the base.

ASSEMBLY

1. Check the transit screw [1], located beneath the turntable in a central recess. The large circular nut on the transit screw should have been fully tightened (clockwise as viewed from below) when the turntable was packed. If it is tight, the turntable's floating chassis assembly will be resting firmly on the bottom of the turntable base and the sub-platter [9] will be approximately level with the upper surface of the turntable's base (plinth).

NOTE: WHEN CHECKING OR ADJUSTING TRANSIT SCREW, CAREFULLY TILT TURNTABLE TO A MAXIMUM OF 45 DEGREES.

DO NOT INVERT TURNTABLE, AS SUB-PLATTER MAY FALL OFF.

2. Set the speed change knob [6] at 45 rpm. DO NOT plug in the AC power cord until instructed to.
3. The rubber drive belt [7] was pre-installed at the factory. Check to see whether it may have slipped out of place during shipment. The belt runs around the rim of the sub-platter [9] and around the large upper portion of the motor pulley [8]. Make sure that the belt is not twisted at any point along its length.
4. Rotate the sub-platter [9] by hand in a clockwise direction (as viewed from above), and check to see that the belt is running smoothly. While continuing to turn the sub-platter, re-set the speed change knob [6] to 33 rpm. Check to see that the belt shifts down to the lower (smaller) portion of the motor pulley [8] without twisting, and runs near the lower edge of the rim of the sub-platter [9].
5. Check the label on the bottom of the turntable to be sure that your AC power line voltage and frequency meet the turntable's requirements. Plug the AC power cord [4] into a household AC mains outlet, or into an accessory outlet socket on your amplifier.

NOTE TO U.K. USERS: The wires in the power cord are colour-coded as follows: Brown = live, Blue = neutral. As this may not correspond to the identifying colours in your power plug, you should connect the wires to the plug as follows: connect the Brown wire to the terminal marked L or coloured Red, and connect the Blue wire to the terminal marked N or coloured Black.

6. To check the operation of the turntable, turn the front-panel STOP/PLAY knob [13] to the right (clockwise), to the horizontal PLAY setting. Note that the adjacent pilot light [14] illuminates, the motor starts, and the sub-platter turns. Re-set the speed-change knob [6] to 45 rpm and check to see that the belt [7] moves up to the large upper portion of the motor pulley [8], causing the sub-platter to rotate faster. Re-set the speed-change knob to 33 rpm and note that the belt drops down to the lower pulley without twisting. Turn the PLAY knob back to STOP, and unplug the AC power cord.

7. Rotate the large nut on the transit screw [1] to the left (counterclockwise) as viewed from below. Continue unscrewing the nut until it reaches the lower end of the transit screw. The turntable's internal chassis will rise up above its normal operating position, suspended on three pressure springs, and so that the top surface of the sub-platter [9] is several millimeters above the top surface of the turntable's base (plinth).

CAUTION: Do not turn on the motor, nor rotate the sub-platter by hand, while it is floating in a raised position



The lightning flash with arrowhead, within an equilateral triangle, is intended to alert the user of the presence of uninsulated "dangerous voltage" within the product's enclosure; that may be of sufficient magnitude to constitute a risk of electric shock to persons.



The exclamation point within an equilateral triangle is intended to alert the user of the presence of important operating and maintenance (servicing) instructions in the literature accompanying the appliance.

on the springs without the weight of the platter assembly to pull it down to the correct operating height. If you turn it, the belt may slip off the lower edge of the sub-platter's rim and will have to be re-installed.

8. Locate the main platter assembly. It consists of three parts: a metal platter disc [10], a heavy rubber platter mat [11], and a center-hole adapter [12] with two finger-size holes. The rim of the metal platter disc is turned up and fits into a groove in the lower surface of the rubber platter mat.

9. Temporarily remove the center-hole adapter [12] and set it aside. Install the platter assembly [10, 11] on the sub-platter [9]. (The metal platter disc [10] fits on the center spindle and rests on the sub-platter, while the rubber platter mat [11] rests on top and provides the supporting surface for gramophone records.) Note that the weight of the platter assembly is precisely offset by the pressure of the chassis springs so that the chassis "floats", free to move in any direction (either vertical or horizontal) at least 1/4th of an inch (± 3 mm) without obstruction or friction.

10. Re-install the center-hole adapter [12], sliding it down the central spindle until it is fitted into the recess in the center of the rubber mat. Note that the adapter can be inverted. In the normal orientation its flat upper surface is flush with the surface of the platter mat, so that an LP disc will be in uniform contact with the vibration-absorbing rubber platter mat over most of its surface area. When the adapter is inverted (with its smooth side down), the protruding 1 1/2-inch (37 mm) ring in its top surface provides correct centering for 45 rpm records having a large center hole. The two finger holes provide a convenient means of grasping the adapter in order to install and remove it.

11. Unpack the plastic dust cover [2]. Note that it has two bends: a 45-degree bend (at the FRONT) and a 90-degree bend (at the REAR). The cover fits into two spring-loaded hinges [3] that are mounted in slots at the rear of the turntable. Each hinge has an open slot to receive the dust cover, tilted about 45 degrees up to the rear. Simply hold the dust cover up at an angle and slip its rear lip into the hinges (it may be a tight friction fit). The spring-loaded hinges will hold the dust cover in its fully raised position. When closed, the cover sits on two small rubber bumpers mounted in the side panels near the front.

Temporarily remove the dust cover and set it aside while installing and adjusting the tonearm.

TONEARM INSTALLATION

Instead of a conventional plug-in headshell, the NAD 5120 turntable employs a plug-in tonearm assembly. The four connecting pins on the lower surface of the tonearm are designed to plug into the four-pin socket [17] that is suspended within the tonearm pivot assembly [16]. We suggest that you familiarize yourself with this plug-in arrangement by installing and removing the arm a few times before mounting a pickup cartridge.

If a pickup cartridge has already been pre-mounted on the tonearm, you can proceed directly to the section on adjustment of the Dynamic Vibration Absorber.

In order to plug the tonearm into its socket, the four pins on the arm must be aligned with the corresponding holes in the socket. To align the tonearm socket, rotate the pivot assembly [16] counter-clockwise as far as it will go. Press the pivot assembly down until it strikes the bottom of the turntable base, and hold it securely in place with one hand. With the other hand, grasp the flat tonearm near the connecting pins, hold it parallel to the edge of the turntable, and insert the pins into the connecting socket. Press firmly down on the tonearm to push the four pins all the way into the socket, until the tonearm is nearly flush with the top of the pivot assembly.

The fifth pin on the lower surface of the flat tonearm fits into a slot in the top of the rest post [29], securing the arm when it is not in use.

To remove the tonearm, first raise the front of the arm to extract the securing pin from the slot in the rest post. Grasp the pivot assembly [16] with one hand and push down to brace it against the bottom of the turntable base, holding it securely. With the other hand, grasp the tonearm on either side of the connecting pins, and pull straight up.

PHONO CARTRIDGE MOUNTING

When you are installing a phono cartridge you probably will want to turn the tonearm over. Before doing so, unscrew the DVA damping rod [18] until it projects at least 2mm above the tracking force wheel, so as to seal the oil chamber and prevent leakage.

It also is wise to remove the stylus assembly from the cartridge and set it aside temporarily. If the stylus is not removable, keep the plastic stylus guard in place whenever possible in order to prevent accidental damage to the delicate stylus assembly.

Refer to the instructions supplied with your pickup cartridge for any specific advice on installation.

Unplug the tonearm from the turntable. Locate the cartridge between the two elongated slots at the front end of the tonearm. Most cartridges have a flat upper surface which should be in uniform contact with the lower surface of the tonearm.

Select mounting screws long enough to pass through the tonearm and through the mounting holes or slots in the cartridge body. (Caution: if the screws are too long they may interfere with the proper seating of the stylus assembly on the cartridge body.) Select screws with wide heads, or install flat washers beneath the screw heads, in order to provide a large bearing surface that will securely grip the tonearm when the screws are tightened. (If you choose to run the screws upward from the cartridge through the arm, rather than downward from the tonearm through the cartridge, place the washers under the nuts. See Figure 1.)

Do not completely tighten the mounting screws at first. Tighten them just enough to hold the cartridge in place while still allowing its position to be adjusted.

Before proceeding with the alignment, connect the tonearm wires to the terminals on the rear of the cartridge and set the vertical tracking force, as described in the instruction manual for the NAD 5120.

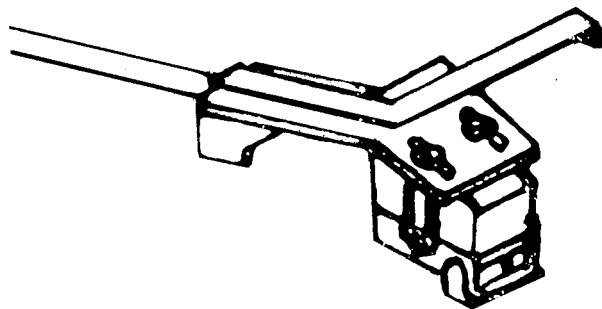

Figure 1. Mounting

PHONO CARTRIDGE WIRING

If the turntable was supplied with a pickup cartridge pre-installed in the tonearm, you can skip over this section

and proceed directly to the adjustment of the Dynamic Vibration Absorber.

The four cartridge connecting leads on the tonearm are wired in accordance with the standard colour code, as follows.

- White — **L** Left channel signal (hot)
- Blue — **LG** Left channel ground
- Red — **R** Right channel signal (hot)
- Green — **RG** Right channel ground

The connecting leads terminate in small clips that fit onto the terminals on the rear of the phono cartridge. Using tweezers or small-nose pliers, slide each clip fully onto the cartridge terminal that corresponds to its colour code. The clips should have a snug friction-fit on the terminals. If they fit loosely, use small-nose pliers to squeeze the clips *very carefully*.

CAUTION: Never solder connecting leads directly to the terminal pins on the cartridge; doing so can severely damage the cartridge. Similarly, never solder terminal clips onto the connecting leads while the clips are installed on the cartridge pins. If you accidentally break off one of the clips, have an experienced technician install a new clip on the connecting lead.

Examine the connecting leads to be sure that each clip is securely in place on the corresponding cartridge terminal, and check to see that the clips are not touching each other.

BALANCING THE TONEARM

If your phono cartridge was supplied with a stylus guard, install the guard to protect the stylus while handling the arm. Plug the tonearm into its socket. Then, if the stylus guard is not a permanent part of the cartridge, remove it before balancing the arm. Unplug the AC power cord so that the Stop/Play control can be set to PLAY without causing the platter to rotate.

Disengage the tonearm from its rest post, and hold it just to the left of the rest post. Turn the control knob to PLAY and wait while the cueing post [31] gradually descends, until the tonearm is completely free to move up and down. Rotate the tracking force wheel [22] until the arm is precisely balanced, floating in a level position. When it is accurately balanced, you can push the front of the arm slightly up or down and it will return to the level position.

If the phono cartridge is a low-mass model weighing less than 4 grams (e.g. the Ortofon Concorde series), it may be impossible to balance the arm—or, having balanced the arm, you may find that there is insufficient range of counterweight adjustment remaining to allow you to set the correct vertical tracking force. In this case, it is possible to rotate the entire counterweight assembly so as to place the weight closer to the arm pivot. First, turn down the DVA frequency setting screw [25] until the top of the screw is flush with the top of the counterweight, and turn the tracking force wheel until it is located approximately midway along the slot in the tonearm.

The assembly is held in place by a powerful spring washer [24] bearing against the under surface of the tracking force wheel [22]. Press down hard on the tracking force wheel to flatten the spring washer, and rotate the entire assembly 180 degrees (a half-circle) so that the counterweight is facing forward. Release the pressure on the tracking force wheel, and the assembly will re-engage the slot in the arm and lock, as before. (If you have any difficulty with this procedure, your NAD dealer can show you how it is done.) Re-set the DVA frequency screw [25] to the desired setting, and proceed to balance the arm.

When the counterweight is in the reversed position, the effectiveness of the Dynamic Vibration Absorber is reduced.

So it is preferable to keep the counterweight in the normal orientation whenever possible. If you can balance the arm with the weight in the normal position but can't move the counterweight forward enough to set the tracking force, it may prove preferable to add a gram of extra mass (in the form of a shim between the cartridge and the arm) instead of rotating the counterweight assembly, in order to retain optimum damping of the infrasonic arm/cartridge resonance.

SETTING THE VERTICAL TRACKING FORCE (VTF)

After balancing the tonearm, secure the arm in its rest post. Use one hand to grasp the periphery of the tracking force wheel [22] so that it cannot turn. With the other hand, rotate the VTF dial [23] until the zero (0) is aligned with the white index mark in the middle of the arm. (The VTF dial normally rotates with the tracking force wheel, but it can be turned separately by placing the tip of a screwdriver, ball-point pen, or a fingernail in the small slot provided.)

After thus calibrating the VTF dial to indicate 0 when the arm is balanced and level, set the vertical tracking force (VTF) by turning the entire tracking force wheel clockwise, until the desired VTF is aligned with the white index mark. The dial is calibrated from 0 to 3 grams (30 milliNewtons), with dots at the 0.5 gram points.

Refer to the instructions supplied with your pickup cartridge to learn the optimum setting of vertical tracking force. If a range of permissible VTF values is given, the best sound (and lowest record wear) usually will be obtained with a VTF setting in the upper half of the suggested range. One recommended approach is to begin by setting the VTF to the middle of the recommended range, and complete the adjustments below (for anti-skating and cueing height). Then play an assortment of well-made recordings, listening particularly for harsh distortion in the loudest passages. Listen at a moderate volume level in order to be certain that you do not induce distortion by overdriving your amplifier into clipping on the loudest peaks. If you hear distortion due to mistracking, increase the vertical tracking force and note whether the sound is cleaner (but do not exceed the maximum force recommended by the maker of the cartridge).

ANTI-SKATING BIAS

The anti-skating control provides side-thrust compensation to ensure equal stylus pressure on both walls of the record groove. The anti-skating control is a knurled shaft [32] surrounding the lower half of the tonearm rest post [29], with a calibrated dial at the bottom of the shaft displaying values from 0.5 to 3.0 grams. An index marker is molded into the turntable base (plinth) in front of the control. Turn the anti-skating control until the marker indicates a value equal to the vertical tracking force that you have set on the tonearm.

In theory, the optimum anti-skating compensation will depend on the shape and polish of the stylus tip, and is best determined by using a test record. The calibrated scale will provide approximately correct settings for normal pickup cartridges with elliptical styli. For Shibata, hyperelliptical, and other line-contact styli, set the anti-skating dial to a value about 30 percent higher than the VTF setting (e.g. if the VTF is 1.2 grams, set the anti-skating to about 1.5). For spherical-tipped styli, set the anti-skating value about 25% lower than the VTF (e.g. if the VTF is 2 grams, set the anti-skating to about 1.5). It is not necessary to make the adjustment exact, since all anti-skating compensation is only approximate anyway.

CUEING HEIGHT

The Stop/Play knob controls an arm-lift cueing mechanism [31] that lifts the cartridge off the record at the beginning and end of play, and lowers the stylus gently into the groove to begin play. The height of the arm-lift is adjustable to compensate for the varying depth of cartridge bodies. To adjust it, first check to see that the removable tonearm has been pushed fully downward into its socket [17]. Place a record on the platter, turn the Stop/Play control to the STOP-LIFT position, and move the tonearm over the record. With the arm cued "up" the stylus should be approximately 5 to 7 mm ($\frac{1}{4}$ inch) above the record. If the distance is different, correct it by turning the threaded shaft [30] in the top of the cueing post. To check the adjustment, turn the Stop/Play knob to PLAY. The stylus will drop into the groove, and the cueing post [31] will lower a little further until it is no longer in contact with the tonearm.

PHONO CARTRIDGE ALIGNMENT

In order to minimize distortion the pickup cartridge must be precisely aligned in three angles and one linear dimension.

The *front/back* tilt of the cartridge affects its vertical tracking angle (VTA). Normally the VTA will be correct when the upper surface of the cartridge body is parallel to the record surface. With cartridges of typical height this requirement is satisfied by fastening the cartridge directly to the under-surface of the tonearm.

If this is unsatisfactory because of a non-standard cartridge height or because you are using a line-contact stylus whose vertical angle is especially critical, the VTA can be adjusted in either of two ways. (1) Place a shim between the tonearm and the front or rear of the cartridge body. (2) Take advantage of a unique property of the flexible arm: when bent beyond its elastic limit it tends to retain the bend. Thus, to decrease the VTA, simply grasp the tonearm firmly in both hands and bend the front half of the arm upward.

The *rotational tilt* affects the stereo separation. To test it, place a small flat mirror on the platter mat. Unplug the AC power cord so that the arm can be cued down without causing the platter to rotate. Lower the stylus tip onto the mirror, look at it from directly in front, and compare the cartridge with its reflection in the mirror. Ideally, the stylus cantilever and its reflection should form a straight line, while the cartridge body and its reflection are parallel, as shown in Figure 2(b). If you see a tilt, as in Figure 2(a),

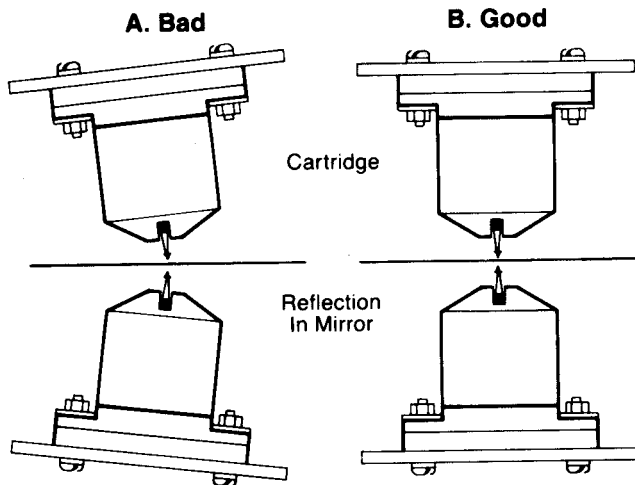

Figure 2. Alignment

it can be corrected in either of two ways. (1) Place a shim under one side of the cartridge body. (2) Grasp the tonearm and twist it.

The stylus *overhang* is adjusted by moving the cartridge and its mounting screws forward or backward along the slots provided. For optimum performance the stylus tip should be located precisely $\frac{1}{8}$ inch (3mm) back from the end of the tonearm, as viewed from the side; see Figure 3.

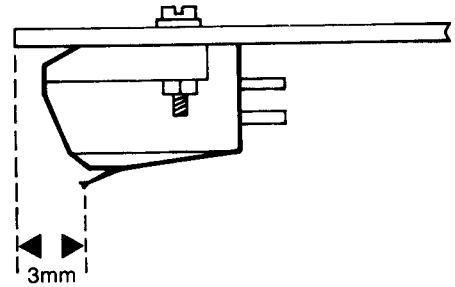

Figure 3. Stylus overhang

If the cartridge conforms to the proposed international standard, in which the axial distance from the stylus tip to the mounting screws is $\frac{3}{8}$ inch (9.5mm), then the mounting screws will be precisely $\frac{1}{2}$ inch (12.5mm) from the end of the arm. This position is marked on the upper surface of the tonearm by dots opposite the *middle* line in the group of five lines adjacent to each slot. This location of the mounting screws will be approximately correct for all phono cartridges; but if you want to obtain the lowest possible distortion, slide the cartridge forward or backward until the stylus tip is precisely 3mm from the end of the tonearm, and tighten the mounting screws.

The cartridge must be mounted at an *offset angle* of 26 degrees relative to the longitudinal axis of the tonearm, in order to minimize lateral tracking distortion. To help you make this adjustment, an "Alignment Protractor" is provided. Place the protractor on the platter mat, with the turntable spindle passing through the hole in the protractor. The protractor has two "alignment points" located at 2.5 and 4.7 inches (63.6 and 119 mm) from the center spindle, each marked by a cross within a circle. If the cartridge is optimally aligned at these two points, minimum distortion will be obtained over the entire LP record.

Unplug the AC power cord so that the tonearm can be lowered without causing the platter to rotate. Then turn the platter by hand so that the stylus can be placed *precisely* on each alignment point, and compare the outline of the cartridge body with the rectangular grid around each alignment point. (Do not be confused by the edge of the tonearm, which should *not* be parallel to the grid; what matters is the outline of cartridge body.)

NOTE: In order for this test to be valid, the stylus must be placed exactly at the center of the circle at each of the two alignment points. It may be helpful to use adhesive tape to stop the platter from rotating, so that the position of the protractor will be stable.

If the cartridge body is precisely parallel to the grid at both alignment points, the geometrical alignment is correct. If necessary, twist the cartridge body to make it parallel to the grid, and then tighten the mounting screws. If the stylus overhang distance is correct, then twisting the cartridge to obtain the correct offset angle at one alignment point will automatically ensure that the alignment is also correct at the second alignment point.

If you find that the alignment is *different* at the two alignment points, then the overhang is incorrect and

should be re-adjusted as follows. First place the stylus tip on the "inner" alignment point (the one closer to the center spindle), and twist the cartridge body to align it perfectly with the grid. Then move the stylus tip to the "outer" alignment point (the one closer to the edge of the platter), observe the orientation of the cartridge body relative to the grid, and refer to Figure 4 to see whether the cartridge body should be moved forward or backward along the slots. (The angular misalignments in Figure 4 are exaggerated for clarity.) If the angular misalignment at the outer alignment point is barely visible to the eye, then the cartridge should be moved forward or back a distance equal to the separation of the calibration marks on the tonearm (0.8mm). The adjustments for overhang and offset tend to affect each other, so you will then have to readjust the lateral twist of the cartridge to achieve correct parallelism at the inner alignment point, and finally re-check the alignment at the outer alignment point.

MOVE CARTRIDGE FORWARD
(CLOSER TO END OF ARM)

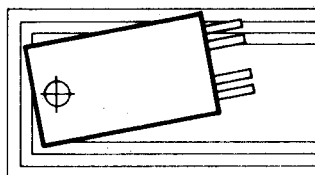

MOVE CARTRIDGE BACK
(AWAY FROM END OF ARM)

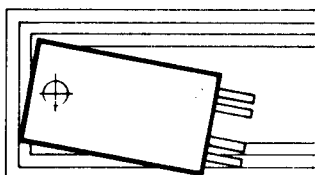

Note: Align cartridge exactly at inner alignment point before testing at outer alignment point.

Figure 4. Cartridge Alignment At Outer Alignment Point.

THE DYNAMIC VIBRATION ABSORBER

The counterweight is not mounted rigidly to the tonearm but rather is suspended on a spring, forming a compliant assembly that is free to vibrate. When correctly tuned its vibration matches and cancels (i.e. absorbs) the fundamental arm/cartridge resonance. (This resonant vibration occurs in all tonearms as a result of the interaction of the compliance of the phono stylus assembly and the effective mass of the tonearm.) Two adjustments on the counterweight assembly control the performance of the Dynamic Vibration Absorber (DVA).

Its frequency is set by means of the white plastic screw [25] that is mounted on the top of the counterweight [27] near the rear, protruding through a slot at the rear of the arm. This screw sets the tension of the spring [26] and therefore the frequency of the counterweight's vibration. Turn it until the *lower end* of the white screw is aligned with the desired resonance frequency on the scale [28] that is provided on the counterweight itself.

The counterweight vibration is "damped" by means of a small threaded rod [18] that is mounted in a hole in the center of the tracking-force wheel [22] and extends down into a chamber partly filled with viscous oil [19]. When shipped from the factory the rod is withdrawn from the oil and protrudes several millimeters above the top surface of the tracking-force wheel [22]; this is done to seal the damping chamber so that the oil will not leak out in transit.

The top end of the damping rod is slotted so that it can be adjusted with the aid of a small jeweler's screwdriver. A

suitable screwdriver is included in the small bag of accessories packed with the turntable. Screw the damping rod [18] down into the oil chamber [19] until the *lower end* of the rod is aligned with the desired damping ratio ("Q") on the scale [21] that is provided on the front of the counterweight. When the tip of the rod is above the "0" mark, there is no damping and the counterweight will vibrate up and down quite freely. When the tip of the rod is immersed in the oil to the Q = 3 level (maximum damping), counterweight vibration is rapidly absorbed.

Recommended settings of DVA frequency and damping for many phono cartridges are provided in the enclosed leaflet. If there is no listing for your specific model, set lower tip of the frequency screw at 10 Hz and the lower tip of the damping rod at 2 (medium damping) for now. Even if these values are not exactly optimum for your cartridge, the result will be better than a conventional rigid tonearm with a fixed counterweight. Refer to Appendix B for further information on the effect of these adjustments and how to discover optimum values for cartridges not listed in the enclosed leaflet.

USING MULTIPLE ARMS

If you wish to use more than one phono pickup cartridge, you can purchase extra plug-in tonearms for the 5120 turntable. On each arm you can set the balance, VTF, and DVA frequency and damping. Then you may quickly swap cartridges by unplugging one arm and plugging another, with no readjustment needed (except, perhaps, for anti-skating and cueing height).

When removing and re-installing tonearms, it is always wise to place a stylus guard on the cartridge body to protect the stylus from accidents.

When you unplug the arm it may seem natural to turn it over and set it down on its back, with the cartridge facing upward, in order to avoid resting the weight of the arm on the delicate stylus. This is NOT recommended. If the arm is inverted for more than a few minutes, the DVA damping fluid may leak out of its chamber. (This leakage can be prevented by unscrewing the damping rod until it protrudes several millimeters above the tracking force wheel.) The tonearm should be stored in normal operating position with a stylus guard protecting the cartridge, perhaps in a tray that has a large cut-out to accommodate the cartridge.

SIGNAL CABLES

The signal cable [5] carries the audio signals for the left and right channels plus a "ground" wire. Connect the audio signal cable to the PHONO sockets on your amplifier. (The red plug is for the right channel. The white, gray, or black plug is for the left channel.)

Connect the ground wire to the Ground terminal on your amplifier. In most cases this connection will minimize hum. However, if you experience a persistent low-frequency hum in the audio signal when using this turntable, try disconnecting the grounding wire and see whether that lessens the hum.

AC PLUG POLARITY

If the AC plug supplied with your player is of the kind that is reversible in the socket, you should experiment to find the plug polarity that yields the least hum in the reproduced sound. After the cartridge installation has been completed, switch on the turntable by rotating the control knob to PLAY. Set your amplifier's input selector to PHONO, turn up the Volume and Bass controls to higher than normal settings, and note the level of low-frequency hum in the

sound. Turn down the Volume control, reverse the turntable's AC plug in the socket, restore the Volume control to exactly its previous setting, and note whether the low-frequency hum is louder or softer than before. Leave the AC plug in the orientation that produces the least hum.

PLAYING RECORDS: THE OPERATING CONTROLS

Before playing a record, set the Speed Change control [6] to 33 or 45 rpm, as appropriate.

When playing 45 rpm records having a large center hole, invert the center hole adapter [12]. Place the thumb and middle finger in the finger holes provided in the adapter, lift the adapter off the spindle, turn it over, and re-install it. Don't forget to re-invert it, with the flat side up, before playing LP records.

To play a record, first be sure that the Stop/Play control knob is in the STOP position and the tonearm is securely held in its rest post. Place the record on the platter. Push the tonearm to the left, freeing it from the rest post. Note that it is not necessary to actually grasp or lift the tonearm, since it is held in the raised position by the cueing mechanism. The tonearm can easily be moved to the left or right by lightly pressing the ball of the thumb against the front end of the arm. Move the arm to place the stylus above the lead-in groove of the record. Lower the dust cover.

Turn the Stop/Play control knob to PLAY. The pilot light will illuminate, the motor will start and the platter will come up to speed, and the cueing mechanism will gently lower the stylus into the groove.

If you want to start the platter rotating in order to use a cleaning brush on the record, simply lock the tonearm in its rest before turning the control knob to PLAY. If you have already cued the stylus over the lead-in groove, turn the Stop/Play control knob just one-eighth of a turn clockwise (and hold it there, against the pressure of its return spring) while cleaning the record. The cueing mechanism will not lower the stylus until the control knob is turned all the way to PLAY.

At the end of the record, the wide spacing of the lead-out grooves will activate the automatic stop sensor. The Stop/Play knob will automatically turn to the STOP-LIFT position, the arm will lift up off the record, and the motor will stop. Raise the dust cover and move the tonearm to its rest post before removing the record.

If you want to interrupt play in the middle of a record, simply turn the Stop/Play control knob to STOP-LIFT, and the cueing mechanism will lift the stylus out of the groove. Move the stylus above the point where you wish to resume play, and turn the control knob to PLAY. The platter will come up to speed by the time the cueing mechanism lowers the stylus into the groove.

IMPORTANT: Whenever you are not playing a record, the tonearm should be securely fixed in its rest post. As you move the arm to the right after playing a record, the pin on the arm slides into the slot on the arm rest and is held there by friction.

MAINTENANCE

Remove accumulated dust from the plastic dust cover by wiping with a damp cloth. Do not use a dry cloth; that will tend to create a charge of static electricity on the cover which will attract dust quickly.

APPENDIX A: SELECTING A LOCATION FOR THE TURNTABLE

If you wish to obtain the finest record-playing performance, the location of the turntable should be selected carefully. Several factors may influence this choice:

Hum. If a magnetic phono cartridge (especially a moving-coil pickup) is located close to an amplifier's power transformer or to a powerful electric motor, it will produce a low-frequency hum. Normally it is sufficient to place the turntable at least one meter (three feet) away from your amplifier. If you place the turntable against a wall and hum is found to be a persistent problem, check to see whether a large electrical appliance (such as a refrigerator or air conditioner) is operating just behind the turntable on the opposite side of the wall.

Heat. Vinyl records may be damaged by elevated temperatures and by prolonged exposure to direct sunlight, so the turntable should not be located adjacent to a room heater nor in front of a south-facing window.

Convenience. Of course the turntable should be placed at a height that makes it convenient to use, with sufficient lighting to allow accurate cueing of desired selections and to permit inspection of the stylus when cleaning it. Reserve enough space above the turntable for its hinged dust cover. Ordinarily, of course, the length of the signal cables limits how far the turntable may be from the pre-amplifier. (This limitation applies mainly with moving-magnet cartridges, because their relatively high coil inductance interacts with the capacitance of the connecting cable. If you are using a low-inductance cartridge, such as a moving-coil, then in most cases you can install the turntable wherever you like and use long signal cables to connect to your amplifier.)

Vibration. This is particularly important, since the phono pickup cartridge is sensitive to sub-microscopic vibrations, and so we will discuss the problem in detail. Isolating the record and stylus from external vibrations is a primary requirement of every turntable, and the unusually compliant floating-chassis suspension of the NAD 5120 provides excellent isolation over a broad range of frequencies. However, complete isolation is not possible, for the following reason.

Any compliant suspension has a natural resonant frequency. Above its resonant frequency the suspension is an efficient mechanical filter, preventing the transmission of vibration up from the base to the record or tonearm. Below the resonant frequency, vibrations will pass through the suspension and cause the floating chassis to move; but since the platter and the tonearm are both mounted on the floating chassis they tend to move together, producing little or no relative motion between the stylus and the record.

The principal difficulty, therefore, occurs with vibrations whose frequency is at or near the resonant frequency of the suspension: the resonance tends to amplify the severity of these vibrations. This is true of all turntable suspensions. Therefore the influence of vibration on a record player's performance depends both on the resonant frequency of its suspension and on the spectrum of the vibrations that reach the turntable from its environment.

Many turntables employ a relatively stiff suspension whose resonant frequency is 10 Hz or higher. The advantage of this approach is that vibration amplitudes at this frequency are seldom large enough to cause groove-jumping or other obvious misbehavior of the record player. The disadvantage is that in many buildings there is an inaudible

but virtually permanent spectrum of structural vibrations caused by motors, furnace blowers, the compressors of refrigerators and air conditioners, etc. When these vibrations reach the phono stylus they tend to colour the sound, especially if they are further amplified by the resonance of the arm/cartridge system. (This resonance, due to the effective mass of the tonearm interacting with the compliance of the stylus assembly, is usually found between 7 and 12 Hz with modern high-compliance pickup cartridges.)

The suspension frequency of the NAD 5120 is much lower: less than 4 Hz. Since the suspension filters out vibrations above its resonance, this design provides the most effective isolation of the record and stylus from the commonest kinds of environmental vibration, and therefore it offers the purest sound quality. The low suspension frequency has a disadvantage, however. If large-amplitude low-frequency vibrations reach the turntable they are more likely to cause obvious and perhaps annoying misbehavior, such as "wow" (wobbly pitch) or even skipping of the stylus between grooves. (Of course, unlike persistent colouration of the sound, this obvious misbehavior is relatively easy to identify and correct.)

If your listening room has a concrete floor, or if the turntable is on a shelf that is fastened to a wall, such vibration is unlikely to be a problem. But wooden floors often have a springy low-frequency resonance of their own; dancing or even walking on such a floor may produce large-amplitude vibrations that coincide with the turntable's suspension resonance. If this occurs, the best solution is to place the turntable on a massive object (such as a polished stone slab or a cabinet filled with records), or to isolate the turntable from the floor by placing it on a shelf that is fastened to the wall.

APPENDIX B: TUNING THE DYNAMIC VIBRATION ABSORBER

Recommended settings for the DVA frequency and damping are listed in the enclosed leaflet for many popular pickup cartridges. If no recommendation is available for your phono cartridge, excellent results will usually be obtained by setting the DVA frequency screw [25] to 10 Hz and the DVA damping rod [18] to an intermediate value ($Q = 1$ or 2). Precise settings of the DVA adjustments are not necessary in order to obtain the benefits of the Dynamic Vibration Absorber.

However, if you want to conduct your own experiments to determine the optimum DVA settings for your particular cartridge, you will need a test record that has a frequency sweep or a series of test tones recorded at a high level of vertical modulation, spanning the range from about 15 Hz down to about 5 Hz. A special NAD test record has been created for this purpose, and it includes detailed instructions for tuning and damping the DVA with any pickup cartridge. The record contains a series of high-level "warble" tones ranging in frequency from 5 Hz to 15 Hz. (Each warble tone varies rapidly up and down in frequency over a 1 Hz range centered at the nominal frequency, in order to be certain of picking up any very narrow resonances in the playback system. E.g. the 5 Hz tone varies between 4.5 and 5.5 Hz.)

Superimposed on each infrasonic warble tone is a steady 440 Hz tone recorded at a relatively low level. When you play the record, ideally you should hear only a steady 440 Hz tone since the infrasonic warble tones are below the

normal low-frequency limit of human hearing. But when the infrasonic tone excites the arm/cartridge resonance, the stylus (and, to some extent, the cartridge body and tonearm as well) will shake. This vibration may be large enough to be visible to the unaided eye, if you look closely. In any case the vibration of the stylus in the groove will produce an audible warbling or "flutter" of the 440 Hz tone, due to frequency intermodulation distortion (F.I.M.).

The first step in DVA tuning is to measure the natural frequency of the arm/cartridge resonance, which requires that the counterweight be immobilized. This can be done by wedging some cardboard or styrofoam into the space above and below the counterweight, so that the counterweight is no longer free to vibrate on its spring. Another approach is to screw the damping rod [18] down into the fluid to obtain maximum damping (Q greater than 3); while this does not completely immobilize the counterweight, it provides a sufficiently stiff mechanical coupling between the arm and the counterweight to allow an accurate measurement of resonance frequency.

Then play the test record, listening for the "flutter," pitch wobble, or warbling quality of the 440 Hz tone that is caused by the arm/cartridge resonance. Play each band of the record, and identify the band in which the worst flutter occurs; or watch the cartridge closely and note which band causes the greatest visible vibration of the stylus assembly and cartridge body. Use the voice announcement on each band of the record to identify the frequency at which the peak resonance occurs. (With some phono cartridges, the 440 Hz tone will be quite steady on some bands, in obvious contrast to the pronounced flutter that is heard on the bands where the peak resonance occurs. With other cartridges, flutter will be heard over the entire 5 Hz to 15 Hz range of the test record, and your task is to identify the band or bands on which the greatest amount of audible flutter occurs.)

Unscrew the damping rod [18], or remove the shims that you installed to immobilize the counterweight, and check to see that the counterweight is free to vibrate on its spring. Turn the DVA frequency screw [25] until the lower tip of the screw is aligned with the resonance frequency that you have just determined from the test record.

Depending on the amount of internal stylus damping in the cartridge, the resonance peak is likely to span a range of frequencies rather than being sharply tuned to one frequency. When in doubt, set the DVA frequency slightly lower than the median resonance frequency. (For example, if the peak resonance appeared to span the range from 8 to 12 Hz, set the DVA to 9 Hz.) This is for two reasons. (1) If the arm/cartridge resonance is not completely cancelled by the DVA, it is better to cancel the lower-frequency portion of the resonance, leaving the relatively innocuous higher-frequency portion of the resonance uncompensated. (2) As damping is added, the added stiffness will tend to raise the DVA frequency slightly above its nominal value.

The final step is to set the DVA damping rod [18]. With most pickup cartridges the damping is uncritical, and the rod should be set for a moderate amount of damping ($Q = 1$ or 2). If you are using a cartridge that has an unusually small amount of internal stylus damping (e.g. a Grado), you may determine the optimum damping by trial and error: play the test record several times, using different damping values, to find the setting that yields the least audible flutter of the 440 Hz tone.



INTERNATIONAL

LONDON/BOSTON