

Service Manual

Washing machine

Frontloader

AWM 6120/S

Model Version		Page
	AWM 6120/S	
	8570 612 15400	
	Technical data	2 - 4
	Spare part list	5 - 6
	Exploded view	7 - 8
	Wiring diagram	9
	Circuit diagram	10
	Program chart	11 - 15
	Text/Legend	16 - 18
	Family	SC1

Technical data**Dimensions**

Height	85	cm
Width	59.5	cm
Depth	56	cm

Weight

Without packing	73	kg
-----------------	----	----

Main Connection

Voltage	220-240	V
Frequency	50	Hz
Power consumption	2.3	kW
Fuse rating	10	A

Drum

Volume	48	l
--------	----	---

Capacity of dry laundry

Cotton/coloured	5	kg
Cotton rapid	3	kg
Cotton short	5	kg
Easy care	2.5	kg
Easy care rapid	1.5	kg
Easy care short	2.5	kg
Delicate	1.5	kg
Wool	1	kg

Water Level

Level 1		
Switching point	60± 5	mmWc
Switching back point	35± 5	mmWc

Overflow	280 ± 20	mmWc
----------	----------	------

Water level inside the drum

(only switching level inside the drum)

Level 1	25- 39	mm
Overflow	267- 306	mm

Nominal currents

Contacts		
11 - 12	4 (4)	A
11 - 14	16 (4)	A
11 - 16	1 (1)	A

Contact system		
11 - 12 - 14	spring contact	
11 - 16	sliding contact	
Damping system	no	

Door lock

Lock time (20 °C)	3" - 6"
Unlock time	60" - 90"
Nominal voltage	230 V
Nominal current:	
Contact 4 - 5	16 (4) A

Heating element

Kind of heating	Tubular heating element with NTC - sensor	
Nominal Voltage	240	V
Nominal power	2050	W
resistance R 25	22 - 28	Ω
Resistance NTC :		
0°C	35.9	kΩ
30°C	9.8	kΩ
40°C	6.6	kΩ
50°C	4.6	kΩ
60°C	3.2	kΩ
70°C	2.3	kΩ
95°C	1.1	kΩ

Inlet valve

Hot/Cold fill :		
Water temperature max.	60	°C
Rated flow <1 bar	4	l/min
Pressure range	0,5 - 10	bar
Nominal voltage	220 / 240	V
Frequency	50	Hz
Starting voltage:		
< 6 bar	160	V
6 - 10 bar	170	V
Nominal current	35	mA
Nominal power	6	VA
Nominal (20 °C)	3.4 - 4.5	kΩ

Drain pump (synchronous)

Nominal Voltage	230	V
Nominal current	0,3	A
Nominal power	34	W
Frequency	50	Hz
Resistor (coil)	155	Ω ± 7%
Motor protection	170	°C
Capacity(1,25m height)	14 ± 2	l/min

Technical data

Program timer

Type	SC1
Timer basic	4619 712 52201
Timer programmed	4619 744 80832
Nominal voltage	230 V
Frequency	50 Hz

Connector

OA4.1 - OA4.2	5. Option
OA4.3 - OA4.4	6. Option
OB4.1 - OB4.2	3. Option
OB4.3 - OB4.4	4. Option
OC4.1 - OC4.2	1. Option
OC4.3 - OC4.4	2. Option
SLT3.1 - SLT3.3	Temp.selector
SLS4.1 - SLS4.4	Spin speed selector
VCF3.1 - VCF3.3	Valve (cold water)
VHF3.1 - VHF3.3	Valve (hot water)
Pi5.1 =	negative supply
Pi5.2 =	data
Pi5.3 =	clock
Pi5.4 =	positive supply
Pi 5.5 =	negative supply
PL3.1 - PL3.3	Pilot lamp

Connector

M7.1 - M7.7	Motor
DP2.1 - DP2.2	Pump
AQS2.1 - AQS2.2	Aquastopswitch
SET2.1 - SET2.2	NTC
DSS3.1 - DSS3.3	Door switch
PR2.1 - PR2.2	Pressostat
Single connector	
HE2.1 - HE2.2	Heating element
PS2.1 - PS2.2	Pressostat
SM2.1 - SM2.2	mains switch (3 fold connector)

Program 32 positions

	Cotton-/ coloured	Easy care	Delicate	Wool	Silk
Pre wash	02 - 06	03 - 06	04 - 06	-	-
Main wash	07 - 21	12 - 21	14 - 21	17 - 21	18 - 21
Rinse	22 - 28	22 - 28	22 - 28	22 - 28	22 - 28
Spin	29 - 31	29 - 31	29 - 31	29 - 31	29 - 31
Stop	32	32	32	32	32

Ambient temperature	up to 70 °C
Storage temperature	up to 85 °C
Wash speed	54 rpm
Ramp speed	95 rpm
Spin speed	1200 rpm

Resistance (at the selector) :

1160 rpm	4.7 kΩ
960 rpm	3.6 kΩ
780 rpm	2.7 kΩ
580 rpm	1.8 kΩ
440 rpm	1.1 kΩ
95 rpm	0.68 kΩ
0	0

Without resistor on push button switch

released	1160 rpm
pushed	580 rpm

Output

Motor	M7.6 - DSS 3.2	>40 V
Aquastop	AQ2.2 -DSS 3.2	230 V
in pump step	AQ2.1 -DSS 3.2	230 V
NTC		not measurable
Pump	DP2.1 -DP2.2	230 V
Doorlock	DSS3.1 -DSS 3.3	230 V
Pressostat	E4 - E2	230 V
- empty	PR2.1 - E2	230 V
- full	PR2.2 - E2	230 V
Valve (Rast 2,5)	V2.1 - V2.2	>170 V
Options		not measurable
Display module	Pi5.1 - Pi5.4	5 V
	Pi5.4 - Pi5.5	12 V

Motor

Type	MCA 52/ 64 - 148 t.f. WHE 0
Belt ratio	i = 1: 13.1

Resistance contacts

6 - 7	68.7	Ω ± 7%
4 - 5	2.15	Ω ± 7%
5 - 6	1.46	Ω ± 7%
5 - 7	0.65	Ω ± 7%

Technical data

Radio interference supression

Type	ISKRA - KPB 7325
Nominal voltage	230 V
Nominal capacity	250nFX1 + 2 x 22 nFY2± 20%
Derivation current	≥ 4.15 mA (2x2.075mA) at 250V 50Hz
Nominal resistance	1± 5% MΩ

Push button switch

Switch Start	SST
Switch Eco	SEC
Switch Pre wash	SPW
Switch Rinse intensive	SRI
Switch Rinse stop	SRS
Switch Spin reduction	SSR

Spare part list

Model **AWM 6120/S**
Service No. **857061215400**
Version **857061215400**

Pos. No.	12NC Code	Description
001 0	4819 440 19716	Cabinet
002 0	4812 440 19343	Flap
011 0	4819 462 48472	Foot
021 0	4819 440 19715	Front
024 0	4812 440 18998	Panel, rear
025 0	4812 404 38559	Support control board 25 mm
030 0	4812 440 19816	Table top
040 0	4812 417 18787	Hinge
050 0	4819 440 19714	Plinth
061 0	4812 466 88458	Counter weight upper
061 1	4812 466 88459	Counter weight front
061 2	4819 310 39227	Mounting kit Weight top
061 3	4819 310 39228	Mounting kit Weight bottom
081 0	4812 529 18038	Shock absorber until 1200
084 0	4812 466 58001	Silent bloc
086 2	4812 401 18412	Stopper
110 0	4812 498 18139	Handle,door white
130 0	4812 417 28047	Plate Door lock
130 1	4812 417 28048	Plate Doorlock Lower
131 0	4812 417 28046	Lock Door
131 1	4812 417 28045	Pin Door Lock
131 2	4812 492 58022	Spring Door Lock
135 1	4812 498 18137	Knob Door safety
135 2	4812 491 48004	Spring
135 3	4812 290 68153	Holder,adjust. Door Safety
140 0	4812 450 68219	Door glass
143 0	4812 440 19782	Glassdoor frame VBL WH
144 0	4812 440 19589	Frame,door glas DE-WT
191 0	4812 460 68527	Door bellow standard
191 0	4812 460 68532	Door bellow WH grease resistance
191 1	4812 492 18017	Strap
191 2	4819 530 58059	Ring
200 1	4812 418 18226	Tub front
200 2	4812 418 18318	Tub rear
200 4	4812 290 88054	Clamp for tub WH
220 0	4812 418 18191	Drum 1200 0,5MM
271 0	4812 358 18056	V-ribbed belt WH 1250 J5
272 0	4812 528 58027	Pulley DIAM.298
272 2	4812 532 18024	Washer
272 3	4812 505 18371	Nut M 12
292 0	4812 530 58101	Gasket Tub
301 0	4812 452 10937	Control panel AWM 6120/S
303 0	4812 498 78093	Handle
321 0	4812 452 10935	Insert panel
321 1	4812 532 98011	Fastener f. Inlay
331 0	4812 414 58111	Knob,timer VBL cpl.
332 1	4812 513 18097	Push button Start VBL WH
332 2	4812 513 18098	Push button spin speed VBL WH
332 3	4812 513 18099	Push button option VBL WH
400 0	4812 361 58094	Motor 1200-MCA52/WHE0
409 0	4812 362 48004	Brush,carbon motor CESET
421 0	4812 121 18142	Interf.filter 1,00 µ F
430 0	4812 310 18458	Pump SERVICE SET
451 0	4812 259 28765	Heating element 240V with NTC
490 0	4812 321 18043	Connect.cable 5m

Pos. No.	12NC Code	Description
491 0	4812 321 28367	Strain relief
500 0	4812 282 18895	Timer SC1 (EC,PW,IR,RH)
571 0	4812 281 28382	Valve,magnet cold
573 0	4812 271 28449	Valve,magnet hot
581 0	4812 271 28441	Pressostat
620 0	4812 452 10374	Module Timer B S/DS
630 0	4812 280 58026	Door lock 3 TABS
691 0	4812 282 18702	Sensor NTC (SC1)
700 0	4812 530 28869	Hose inlet hot
701 0	4819 530 28848	Hose, inlet
701 1	4819 466 69704	Gasket and filter
702 0	4819 530 29019	Hose intern
702 1	4819 530 28971	Hose, inlet intern
707 0	4812 526 48031	Nozzle Distribution
707 1	4812 526 48028	Nozzle
707 2	4812 526 48034	Nozzle hot
707 3	4812 526 48035	Nozzle hot
708 1	4812 530 48143	Bend
711 0	4819 418 79434	Dispenser
712 0	4812 418 68198	Drawer 3 C. VBL
713 0	4812 418 88019	Flap Detergent Container
717 0	4819 321 28092	Bowden cable
717 1	4812 321 38013	Lever , Nozzle
717 2	4812 321 38012	Holder,adjust.
717 3	4812 278 88017	Slide
717 4	4812 492 38359	Spring , Nozzle
717 5	4812 282 18807	Cam 3 C. SC1/VBL/WH
718 0	4812 526 48051	Siphon
718 1	4812 418 88018	Accessory
753 1	4819 418 68234	Chamber,air
754 0	4812 530 28826	Drainhose
754 1	4812 530 28832	Lock eco
754 2	4812 530 28829	Flange eco
760 0	4812 480 58105	Filter set pump
781 0	4819 530 28847	Hose,draining
782 0	4812 530 28827	Hose Pressostat
787 0	4812 530 28813	Steam hose
787 2	4819 401 18868	Clamp,hose 26,8 mm
794 5	4812 530 58095	Gasket Air trap
900 0	4812 255 18204	Holder Hose outlet
900 1	4812 290 88049	Bracket
900 2	4812 290 88077	Cable clamp
900 3	4812 401 18446	Cable clamp
900 4	4819 401 18872	Clamp,hose
900 5	4819 401 18529	Clamp,hose
900 6	4812 401 18444	Support Heatingelement
900 7	4812 255 18205	Holder Pressostat
900 8	4819 401 18823	Clamp
900 9	4819 404 78449	Support
901 3	4812 401 18549	Clamp,hose
910 5	4812 502 18516	Screw 4,2 x 13
930 0	4819 492 38139	Spring Suspension
941 0	4812 520 28004	Bearing,ball 6206
941 1	4812 520 28066	Bearing,ball 6204
953 0	4812 530 58099	Shaft seal 1200

Spare part list

Model	AWM 6120/S
Service No.	857061215400
Version	857061215400

Pos. No.	12NC Code	Description
961 0	4819 532 68829	Spacer
965 0	4812 466 68545	Cover BK/WH
993 0	4819 530 29028	Bow
993 3	4812 395 58004	Tool

Exploded view

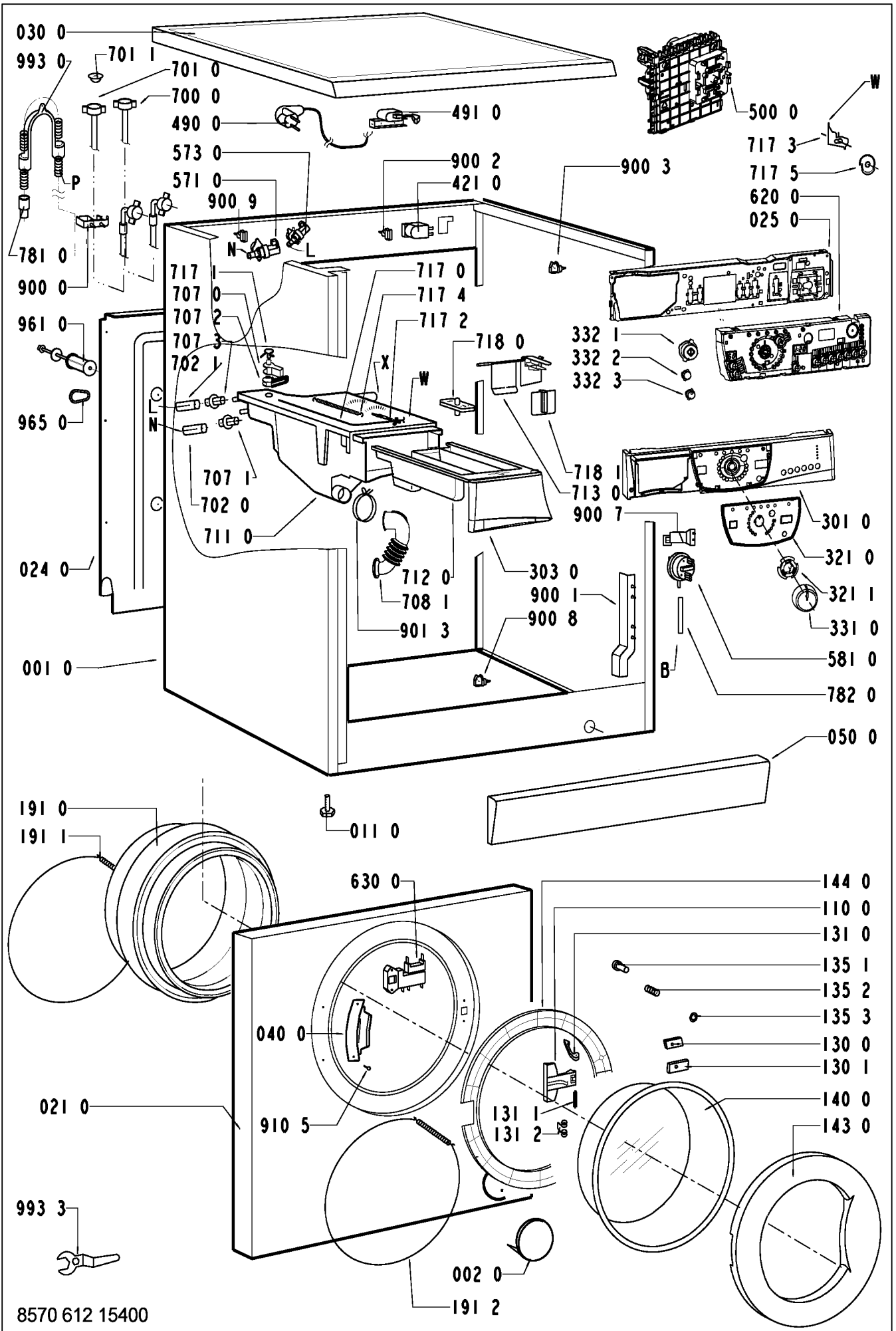

Exploded view

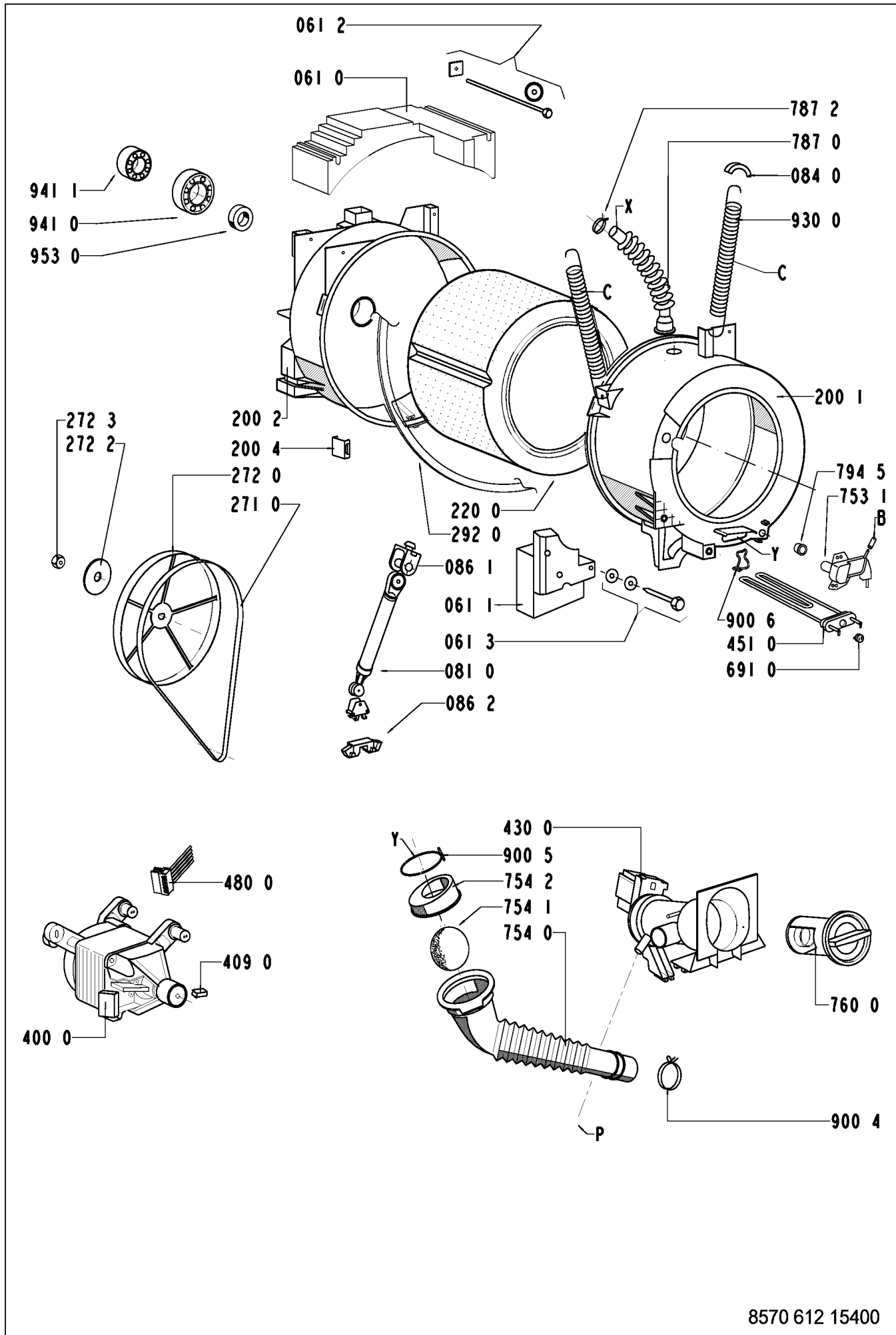

Wiring diagram

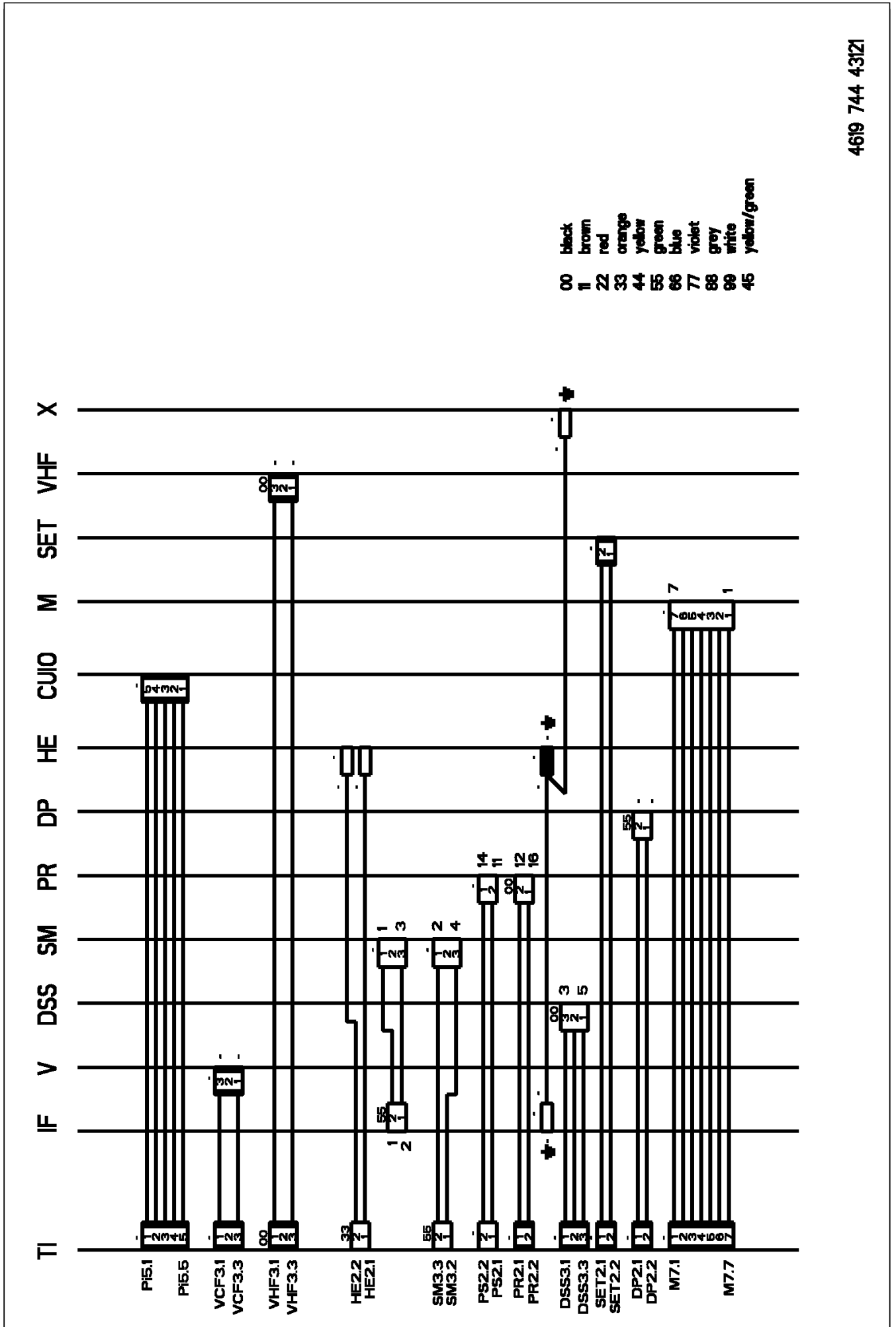

Circuit diagram

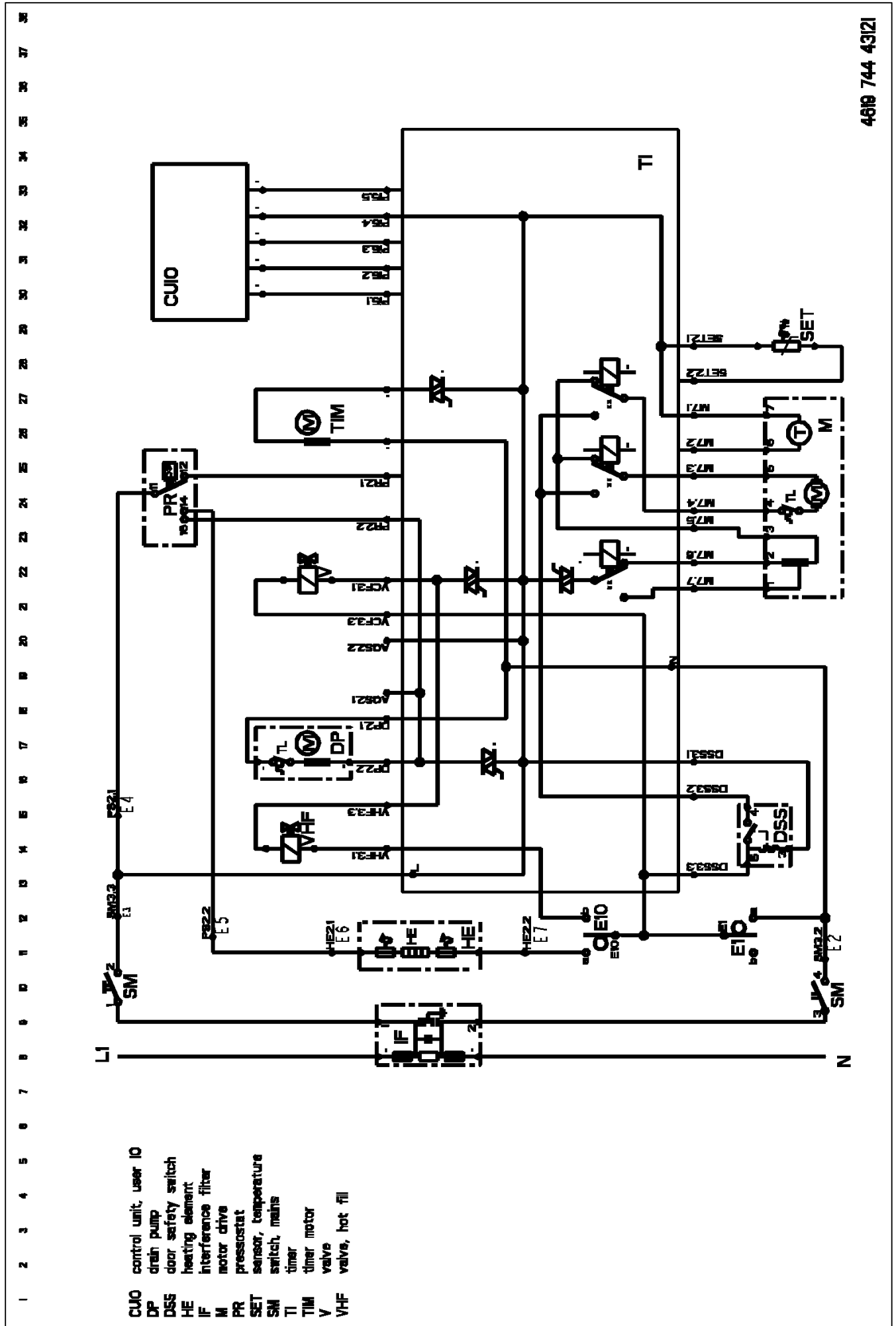

Program chart

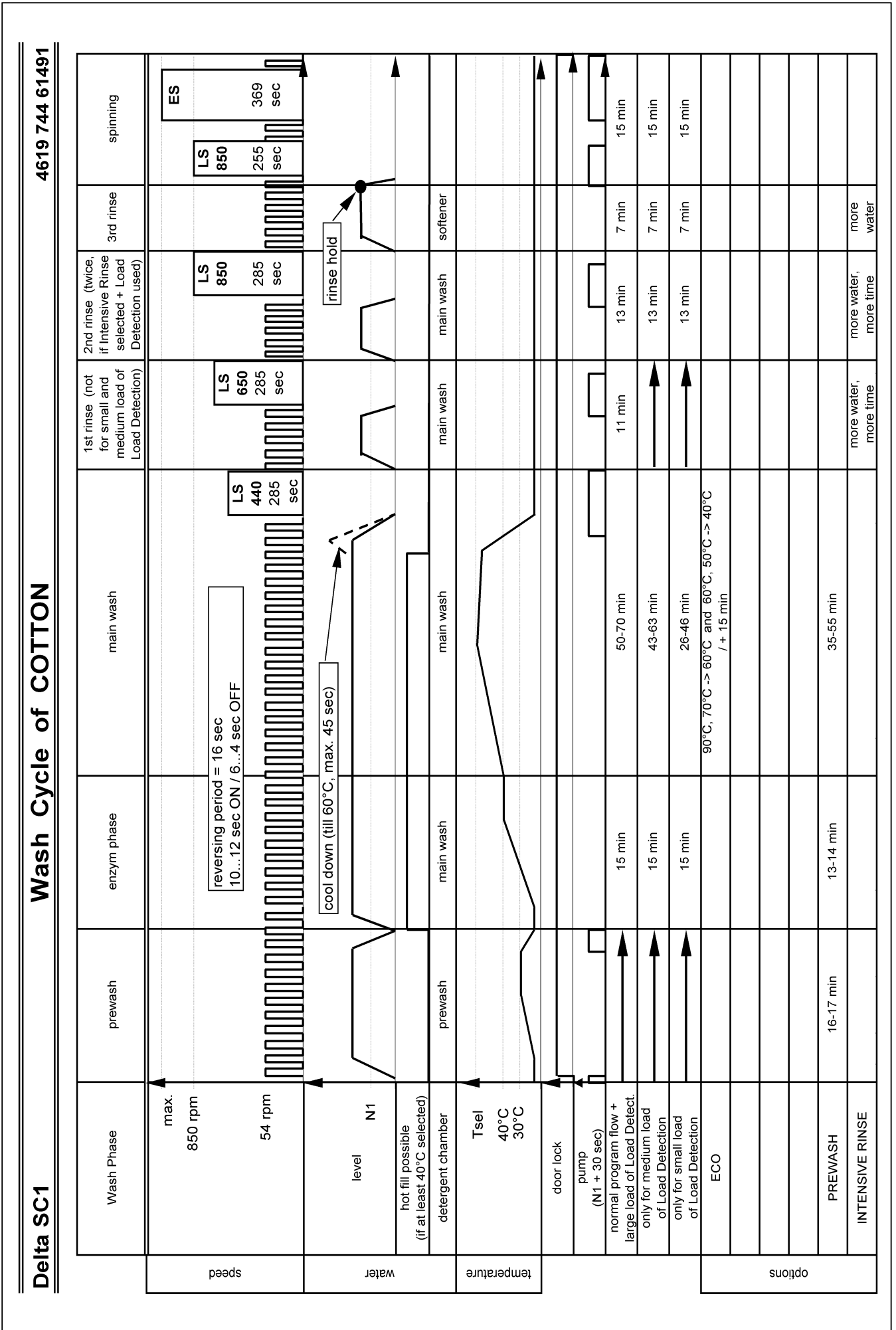

Program chart

Delta SC1

Wash Cycle of SYNTHETIC

4619 744 61491

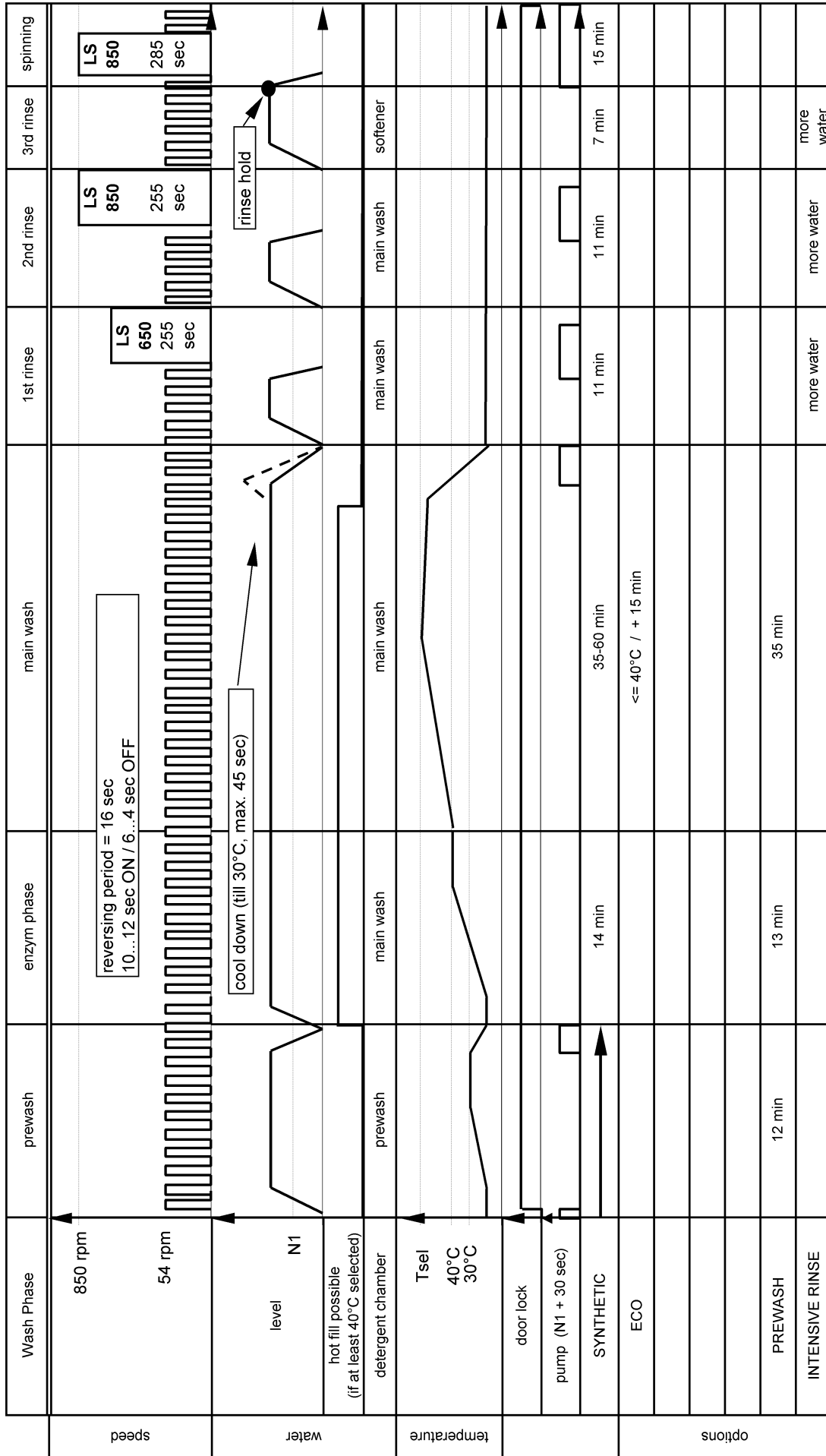

Program chart

Delta SC1

Wash Cycle of DELICATE

4619 744 61491

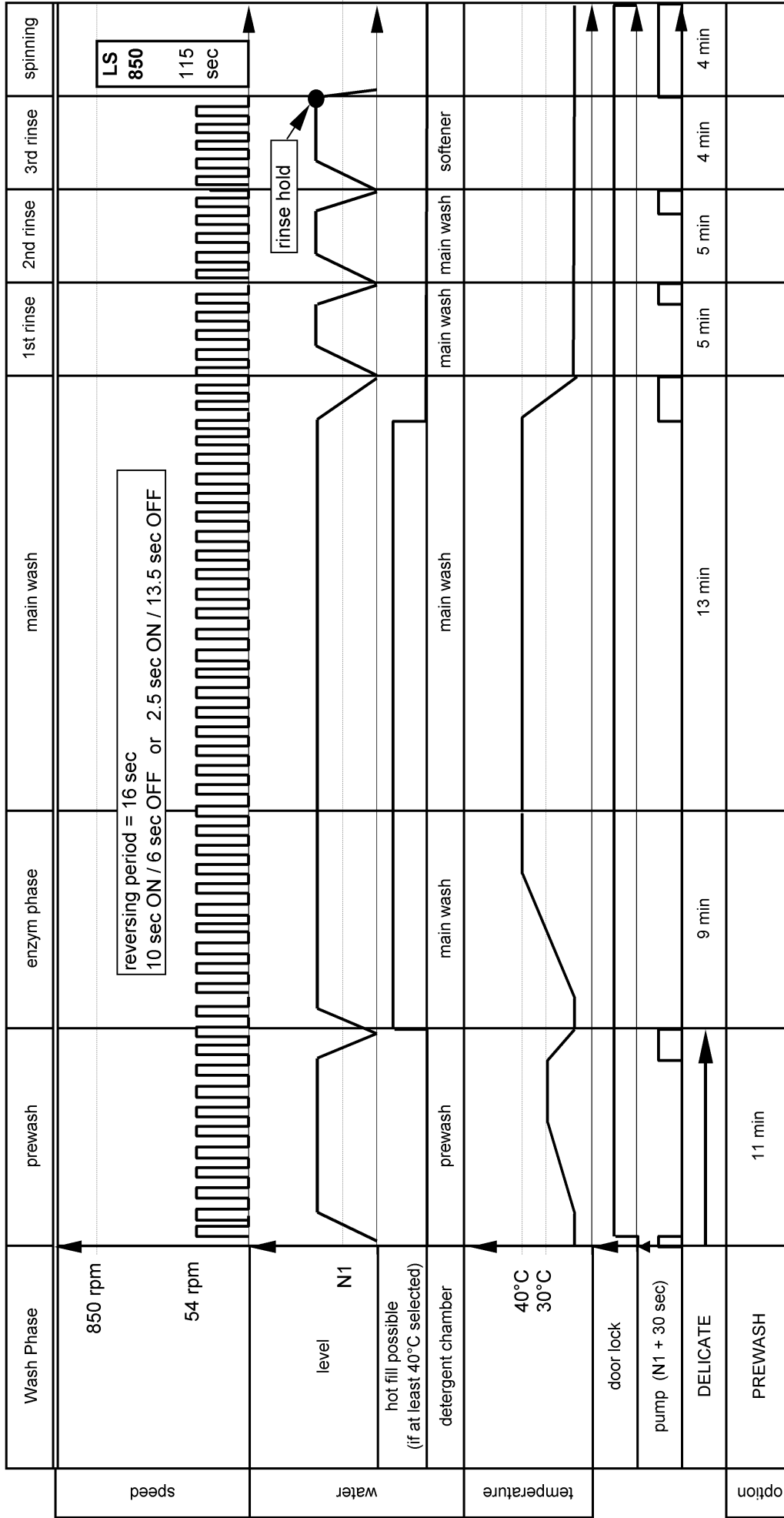

Program chart

4619 744 61491

Wash Cycles of WOOL and SILK

Delta SC1

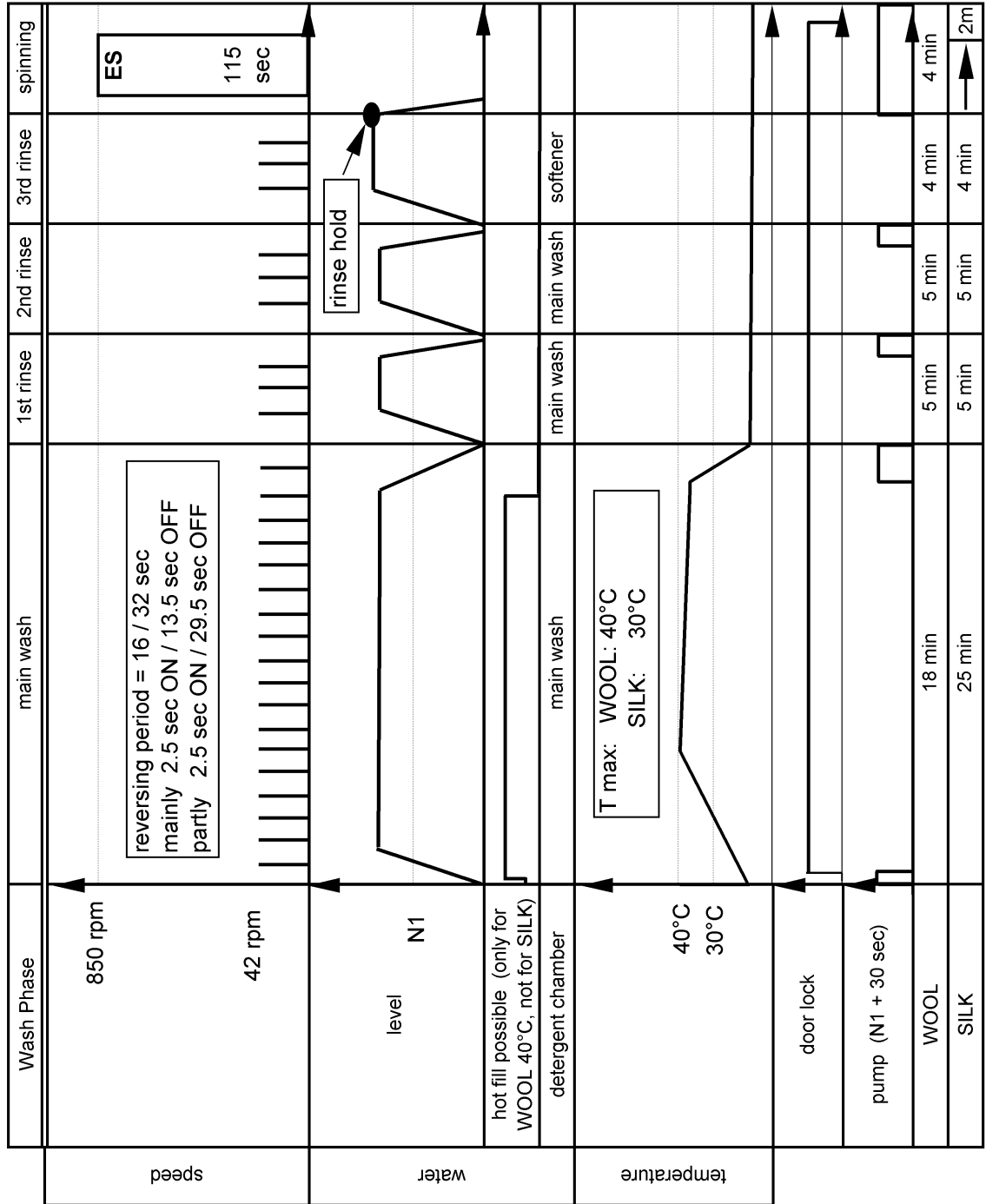

Program chart

4619 744 61491

Spinning Profiles

Delta SC1

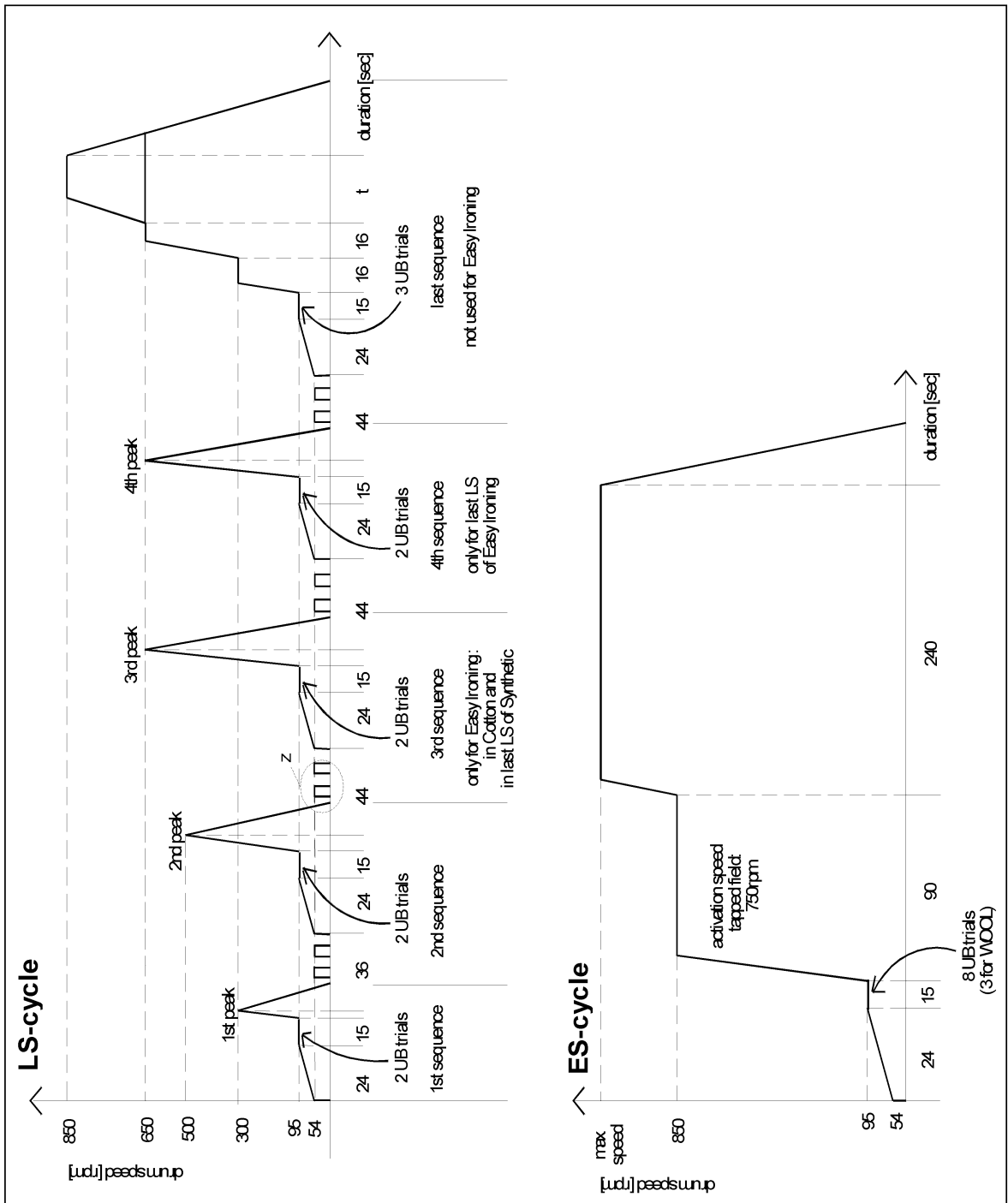

Text/Legend

Whirlpool SC1 VBL Version A and B test flow

1. **Attention : Use test program without laundry !!**

2. **Selecting the program :**

Select the Drain program by turning the main selector. Wait until the display shows 0:02 and till the pump has stopped

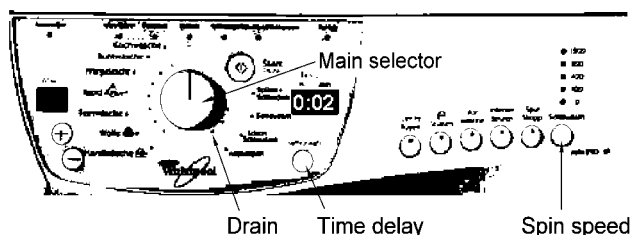

3. **Start of test program :**

Press PB1 twice, then PB2 twice and then the start button.

Indication of entering the test program:

- temperature display = 60°C
- delay start display = 0:00
- speed LED max = ON
- LED of PB1 and PB2 = ON

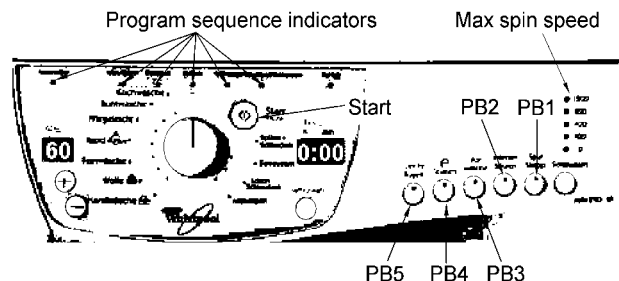

4. **Stopping the test program :**

Stop by moving the main selector into any other position.
- note - no stop of test program by main interruption.

Testprogram for Whirlpool SC 1 timer VBL version A or B (Central program selector).

Position of timer	Program sequence LED's						Detergent box	Inlet / Outlet	Max temp.	Duration (" = sec) (' = min)	Movement of drum	Advance condition	Advance by option button (Press slowly twice)	Checking
	Pre-wash	Main-wash	Rinse	Rinse hold	Spin-ning	Aqua-stop								
-	X	X	X	X	X		-				no movement		PB 3	PB 1, PB 2
6	X	X	X	X	X	X	pre wash	fill		60"	no movement		PB 3	PB 3
8							main wash	(hot) fill	hot fill	60"	no movement		PB 4 **, PB 1	PB 4, mainwash fill, hot fill N1
16		X	X	X	X			fill		6'	gentle wash	N 1		
18								fill			gentle wash	60"	PB 1	
20								(fill)	90°C	55'	gentle wash	till 90°C - time unknown	PB 1	heating, NTC leakage
23			X	X	X		bleach *				turns right	3"		
27							softener	fill			turns left	60"	PB 5 ** or PB 1	PB 5, bleach fill
28				X	X		-	pump		6'	gentle wash	N 1	PB 1	pump, N1
29					X		-	pump			0 - 95 rpm	4", N 1		pump
5							-	pump			select. Speed	300", N 1	PB 1	motor - spinning
							-				no movement	∞		

** if PB 4 / PB 5 / PB 6 are present they must be used to advance to next step - if not present - use PB1 instead.

* 4 chamber detergent dispenser "bleach compartment"

3 chamber detergent dispenser "main wash" compartment

Reaction to failure:

Timer SC1 goes into safety routine

- drain to level 1+30 sec. (time out for draining = 6 minutes)
- stop motor (relais in safety position)
- stop valve
- go out of heating step, if time out is reached

Text/Legend

Table of failures:

Failure Identifier	Indication	Detected failure	To be checked
1	FH	No water inlet	Water Tap / Valve / Flowmeter / Pressostat
2	FA	Aquastop failure	Aquastop switch
3	FP	Drain failure	Drain pump / Pressostat
4		Not active	
5	F05	NTC failure (SC / OC)	NTC
6	F06	Tachometer failure (no motor movement detected)	Motor / Tachometer
7	F07	Triac short circuit detection	Control unit, Motor
8		Not active	
9	F09	Overflow failure	Pressostat
10		Not active	
11	F11	Communication failure	Control unit, I2C bus
12		Not active	
13		Not active	
14	F14	EEPROM failure	Control unit
15		Not active	
16	F16	Control failure	Control unit
17		Not active	
18	F18	Control failure	Control unit
19		Not active	
20	F20	Control failure	Control unit
21	F21	Control failure	Control unit

Display of failures on the speed LED's (flashing):

Errors	1	2	3	4	5	6	7	8	9	10	11	12	13	14	15
	F:H	F:A	F:P	F:4	F:5	F:6	F:7	F:8	F:9	F:10	F:11	F:12	F:13	F:14	F:15
Speed Leds	○	○	○	○	○	○	○	○	○	○	○	○	○	○	○
	○	○	○	○	○	○	○	○	●	○	●	○	○	●	○
	○	○	○	○	●	●	●	○	○	○	○	○	○	○	○
	○	●	●	○	○	●	●	○	○	○	○	○	○	○	○
	●	○	●	○	●	○	○	○	○	○	○	○	○	○	○

Errors	16	17	18	19	20	21
	F:16	F:17	F:18	F:19	F:20	F:21
Speed Leds	●	○	●	○	●	●
	○	○	○	○	○	○
	○	○	○	○	●	●
	○	○	●	○	○	○
	○	○	○	○	○	●

Text/Legend

