

## MULTI-STABILIZER FOR ELECTRONIC TUNING

The TCA750 is basically a stabilizer for use in electronic tuning systems. The circuit is combined with an external reference diode which entirely determines the thermal stability of the system and can be adapted to the stability requirements of AM, FM or TV receivers.

The reference diode BZV38 used in conjunction with the TCA750 form an ideal pair for FM tuners in radio or TV receivers.

Additional to a stabilized voltage ( $V_{O1}$ ) for the electronic tuning system, the TCA750 incorporates two other output voltages ( $V_{O2}$  and  $V_{O3}$ ) for stabilized supply of the entire receiver combination as well as the following attractive features:

- The output current of any of the three stabilizers can be increased by a discrete power transistor without affecting circuit stability.
- For mute control at switching on,  $V_{O2}$  can be delayed by external components.
- An a.f.c. coupling circuit provides a constant correction factor by superimposing an a.f.c. voltage on  $V_{O1}$ .
- Adjustable a.f.c. amplification factor ( $< 5$ ).
- Pulse or touch contact operation switches off the a.f.c. whilst changing stations.
- Delayed switching on of the a.f.c., externally adjustable ( $t_d < 2$  s).
- Search tuning becomes very simple when using the a.f.c. current source (pin 10).
- All three stabilized outputs are protected against short-circuit and are individually adjustable.

**QUICK REFERENCE DATA** see page 2

### PACKAGE OUTLINE

16-lead DIL; plastic (SOT-38).

## QUICK REFERENCE DATA

Input voltage range	$V_{13-16}$	26,5 to 54 V
Ambient temperature	$T_{amb}$	typ. 25 °C
Input voltage	$V_{13-16}$	typ. 45 V
→ Tuning voltage ( $V_{O1}$ ) *	$V_{12-16}$	21 to 34 V
Output current ( $I_1$ ) *	$I_{12}$	< 14,5 mA
Stabilizing time	$t_{stab}$	typ. 0,8 s
Temperature coefficient ( $V_{O1}$ )		
TCA750	$\Delta V_{O1}/\Delta T$	typ. 1 ppm/°C
BZV38		typ. 30 ppm/°C
Line regulation	$\Delta V_{O1}/\Delta V_{in}$	typ. 10 ppm/V
→ Output voltage ( $V_{O2}$ ) *	$V_{14-16}$	8 to 21 V
Output current ( $I_2$ ) *	$I_{14}$	< 6 mA
→ Output voltage ( $V_{O3}$ ) *	$V_{2-16}$	8 to 29 V
Output current ( $I_3$ ) *	$I_2$	< 6 mA

\* Symbols used in test circuit Fig. 3.



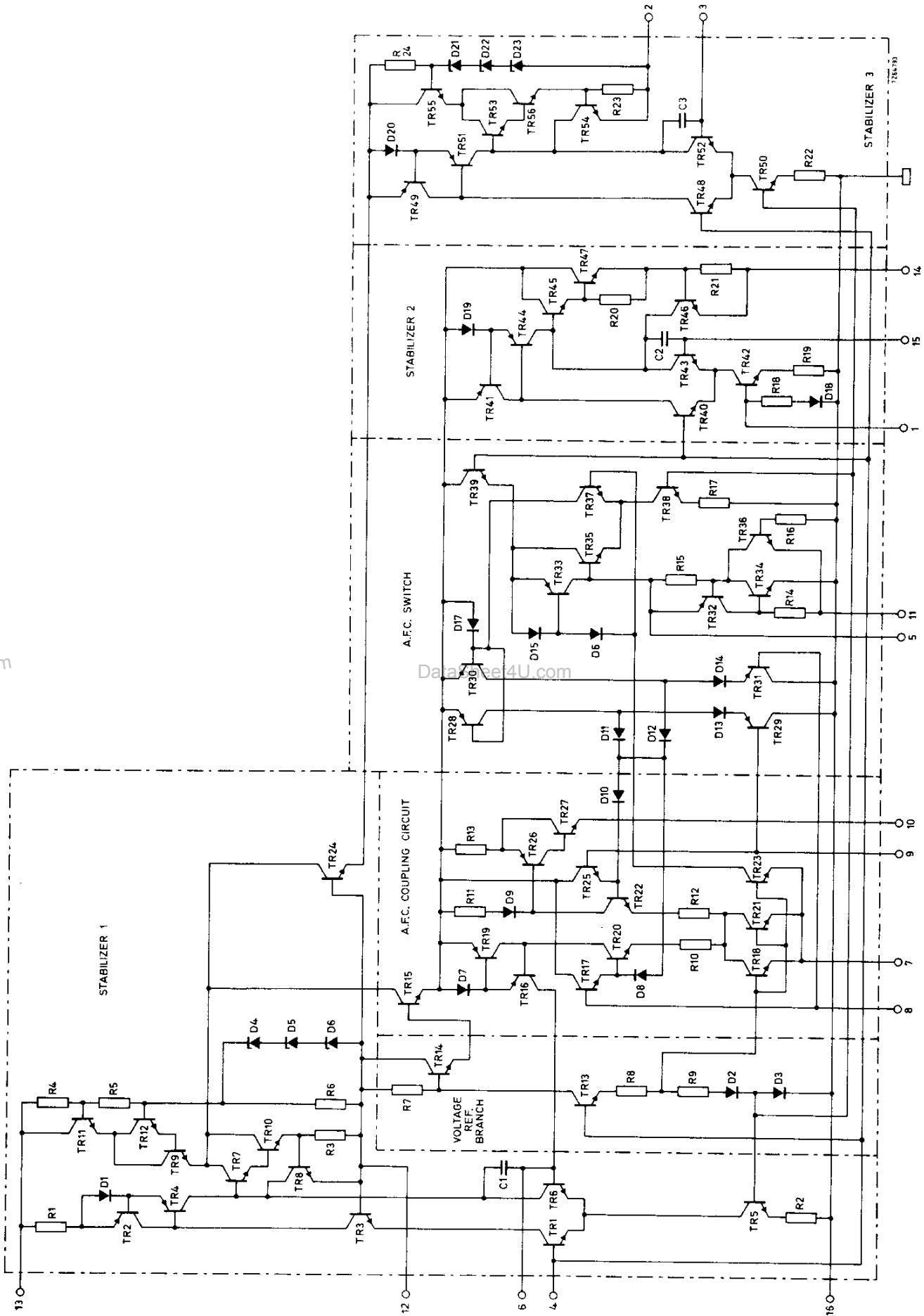

Fig. 1 Circuit diagram.

DataSheet4U.com



183

## RATINGS

Limiting values in accordance with the Absolute Maximum System (IEC 134)

Input voltage (supply)	$V_{13-16}$	max.	54 V
A.F.C. input voltages (pins 8 and 9)	$V_{8-16}, V_{9-16}$	max.	17 V
	$\pm V_{8-9}$	max.	6 V
Output current			
pin 12	$I_{12}$	max.	55 mA
pin 14	$I_{14}$	max.	20 mA
pin 2	$I_2$	max.	25 mA
Input current (pin 11)	$\pm I_{11}$	max.	6 mA
Storage temperature	$T_{stg}$		-55 to + 150 °C
Operating ambient temperature	$T_{amb}$		-25 to + 150 °C *
Total power dissipation			see derating curve Fig. 2

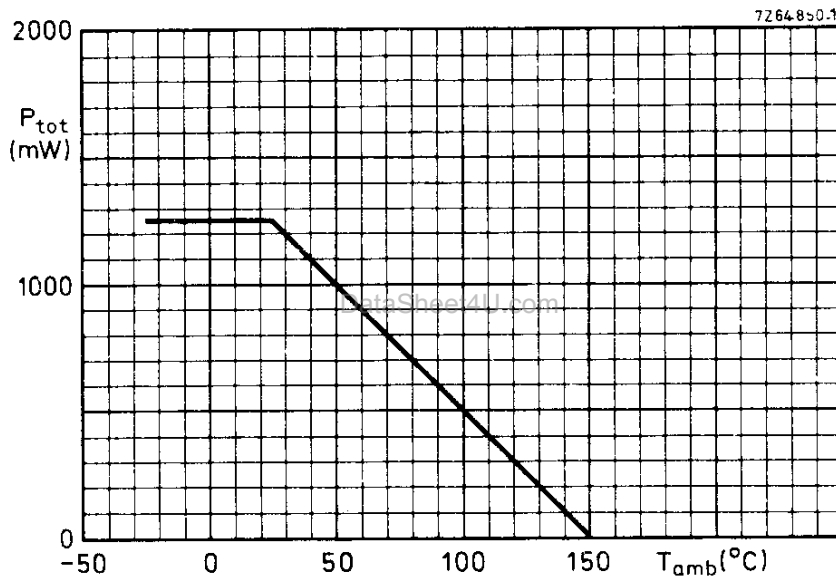
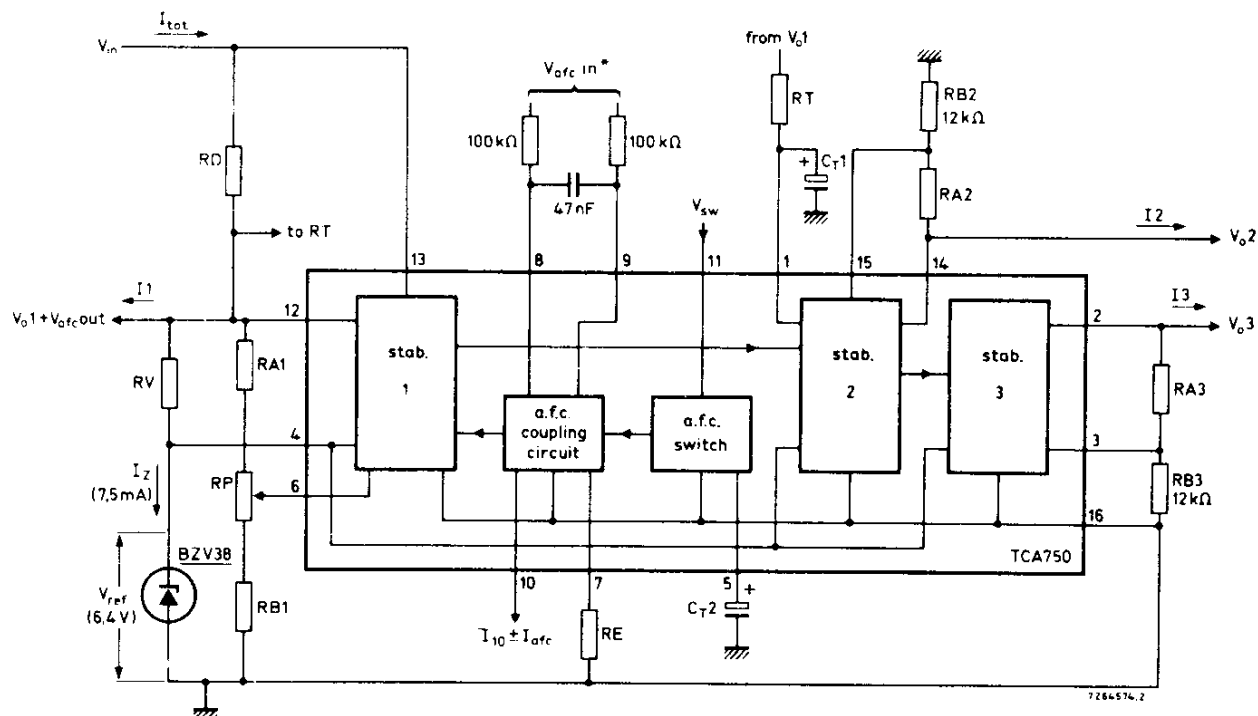

Fig. 2 Power derating curve.

\* See derating curve Fig. 2.



\*  $V_{afc}$  is superimposed on a common-mode voltage ( $V_{com}$ ) of 5 V to 17 V.

Fig. 3 Test circuit and multi-stabilizer peripheral components.

#### Note to power reduction resistor RD

For worst case conditions (maximum output currents of the three stabilizers and a high supply voltage  $V_{in}$ ) the power dissipation ( $P_{tot}$ ) must be reduced by the use of the external resistor RD.

$$\text{Power reduction} = \frac{(V_{in} - V_{O1})^2}{RD}$$

The minimum permissible value of RD is derived by the formula

$$RD_{min} = \frac{V_{in\ max} - V_{O1} - V_{afc\ out}}{I_{12} - I_{13\ min}}$$

where,

$$I_{13\ min} = 4,5\ \text{mA (stand-by current } I_s)$$

$$I_{12} = I_Z + I_{RA1} + I_{1\ min}$$

## CHARACTERISTICS and APPLICATION INFORMATION

T<sub>amb</sub> = 25 °C; see test circuit Fig. 3.

Supplies		note	min.	typ.	max.	
Input voltage	V <sub>in</sub>	1	26,5	—	54	V
Input current	I <sub>tot</sub>	2	—	—	31	mA
<b>Output characteristics</b>						
D.C. output resistance (all stabilizers)	R <sub>out</sub>	—	—	1	—	Ω
Permissible output short-circuit duration						
stabilizer 1	t <sub>short</sub>	—	continuous	—	—	—
stabilizers 2 or 3	t <sub>short</sub>	—	—	—	10	s
<b>Stabilizer 1</b>						
→ Output voltage range (adjustable)	V <sub>O1</sub>	3	21	—	34	V
Output current	I <sub>1</sub>	4, 5	0	—	5	mA
Stabilizing time	t <sub>stab</sub>	6	—	—	1	s
Output voltage temp. coefficient	ΔV <sub>O1</sub> /ΔT	7, 8	—	40	—	ppm/°C
Line regulation	ΔV <sub>O1</sub> /ΔV <sub>in</sub>	8	—	10	—	ppm/V
<b>A.F.C. coupling circuit</b>						
A.F.C. input voltage (½ V <sub>afc</sub> swing)	V <sub>afc in</sub>	—	—	—	5	V
A.F.C. output voltage (½ V <sub>afc lim</sub> swing)	V <sub>afc lim</sub>	15, 16	—	—	0,9	V
A.F.C. output current threshold	I <sub>10</sub>	15, 16	—	—	1,5	mA
A.F.C. output current swing	I <sub>afc lim</sub>	15, 16	—	—	3,0	mA
A.F.C. off delay	t <sub>d</sub>	—	—	2	—	s
Amplification factor	μ	—	—	—	5	—
A.F.C. slope (ΔI <sub>afc</sub> /ΔV <sub>afc in</sub> )	S	14	—	2,5	—	mA/V
Common-mode voltage	V <sub>com</sub>	9	5	—	17	V
V <sub>O1</sub> change due to a.f.c. switching	ΔV <sub>O1</sub> /afc	—	—	—	25	mV
Asymmetry of a.f.c. input (a.f.c. off)	±(I <sub>g</sub> -I <sub>g</sub> )	—	—	—	0,5	μA
<b>A.F.C. switch operated by manual switch</b>						
Input voltage (a.f.c. on)	V <sub>sw</sub>	—	-0,5	—	+0,5	V
Positive input voltage (a.f.c. off)	+V <sub>sw</sub>	—	0,8	—	6	V
Negative input voltage (a.f.c. off)	-V <sub>sw</sub>	—	0,8	—	—	V
Positive input current (a.f.c. off)	+I <sub>11</sub>	—	0,004	—	3	mA
Negative input current (a.f.c. off)	-I <sub>11</sub>	—	0,8	—	2	mA
<b>A.F.C. switch operated by pulse</b>						
Positive trigger pulse peak current	+I <sub>11</sub> pulse	13	—	—	—	—
pulse width = 10 μs		—	800	—	3000	μA
100 μs		—	80	—	3000	μA
1 ms		—	8	—	3000	μA
10 ms		—	4	—	3000	μA
Negative trigger pulse peak current	-I <sub>11</sub> pulse	—	0,8	—	2	mA
Negative trigger pulse width		—	10	—	—	μs

**Stabilizer 2**

		note	min.	typ.	max.		
Output voltage range (adjustable)	$V_{O2}$	10	8	—	21	V	←
Output current	$I_2$	5	0	—	5,5	mA	
Output voltage temp. coefficient	$\Delta V_{O2}/\Delta T$	7, 8	—	45	—	ppm/°C	
Switch-on delay time	$t_{d\ on}$	11	0	—	6	s	
Switching voltage	$V_{1-16}$	—	0,8	—	1	V	

**Stabilizer 3**

Output voltage range (adjustable)	$V_{O3}$	12	8	—	29	V	←
Output current	$I_3$	5	0	—	5,5	mA	
Output voltage temp. coefficient	$\Delta V_{O3}/\Delta T$	7, 8	—	45	—	ppm/°C	

**Notes**

1. The  $V_{in}$  range depends on the value of  $V_{O1}$  (see Fig. 4).
2. At  $I_1 = 5\text{ mA}$ ,  $I_2 = I_3 = 5,5\text{ mA}$ ,  $I_{10} = 0$ .
3. Adjustable by means of  $RA_1$ ,  $RB_1$  and  $RP$ .
4. If a higher level is required from the output of stabilizer 1, the reference diode supply may be obtained from the emitter of a power transistor connected to the output from stabilizer 3 (see Fig. 8). In this case, the current available from stabilizer 1 is increased to 12,5 mA (bleeder current  $I_{RA1} = 2\text{ mA}$ ).
5. At  $T_{amb} = 60\text{ °C}$  maximum with all stabilizers at rated currents.
6. With  $V_{O1}$  within 0,05% of its steady value.
7. Temperature coefficient at  $T_{amb}$  from 10 °C to 60 °C with  $V_{in}$  constant, and using metal film bleed resistors having a temperature coefficient of  $\leq 50\text{ ppm/°C}$ .
8. With all stabilizer output currents constant and within the specified limits.
9. Common-mode voltage = voltage between pins 8 and 16, and 9 and 16 of the I.C.
10.  $V_{O2}$  depends on the value of  $V_{O1}$  (see Fig. 6); adjustable with  $RA_2$ .
11. Adjustable by means of  $RT$  and  $C_{T1}$ . The delay time is limited by the leakage current of  $C_{T1}$ .
12.  $V_{O3}$  depends on the value of  $V_{O1}$  (see Fig. 7); adjustable with  $RA_3$ .
13. The delay time after triggering depends on the value of  $C_{T2}$ .
14. With  $RE = 10\text{ k}\Omega$  and  $T_{amb} = 25\text{ °C}$ .
15.  $V_{afc\ out}$  at  $V_{afc\ in}$  after limiting.
16. With  $RE = 10\text{ k}\Omega$ ;  $RA_1 = 12\text{ k}\Omega$ .

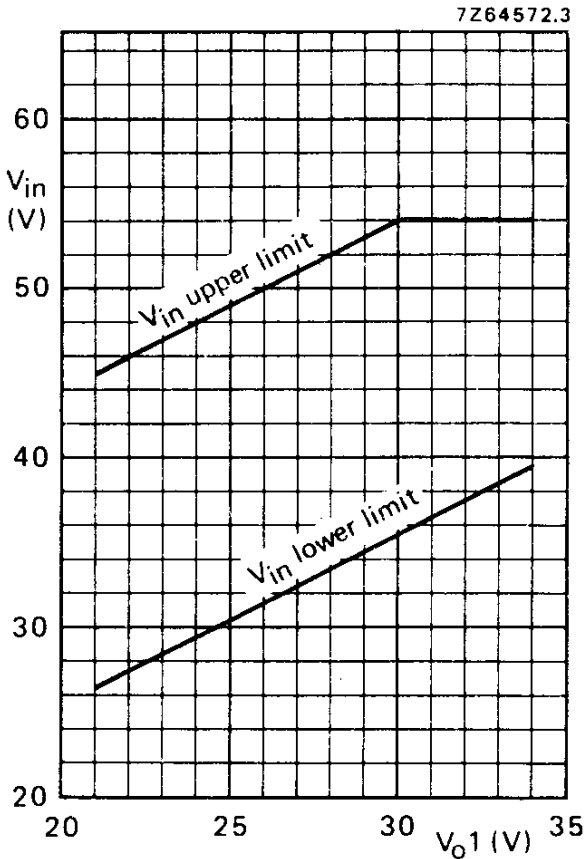

Fig. 4 Range of values for  $V_{O1}$ .

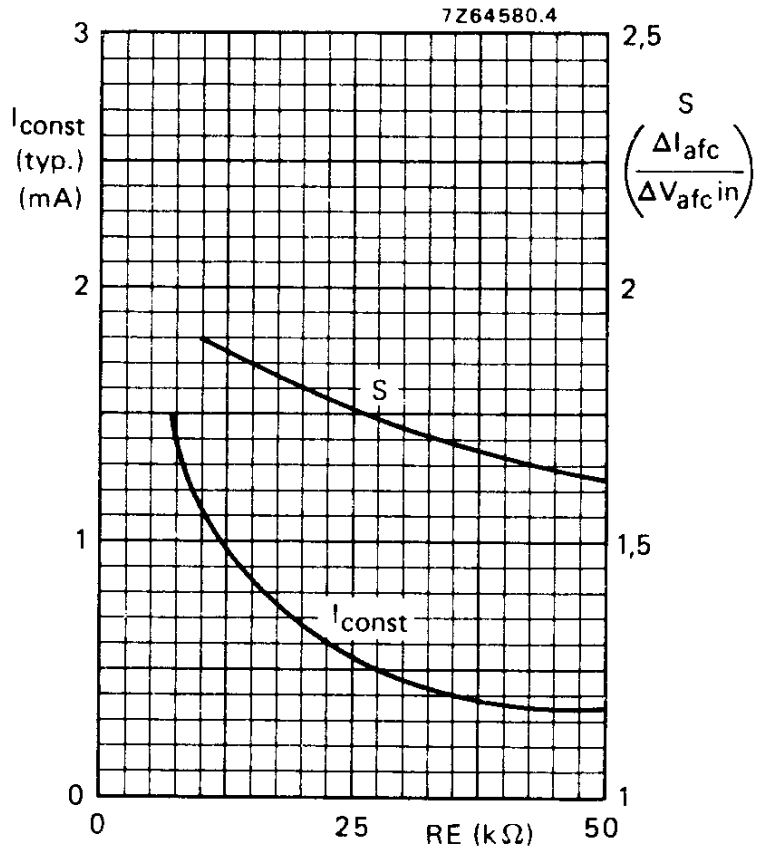

Fig. 5 Determination of  $I_{10}$  and S-factor ( $S = a.f.c. slope$ ) from  $R_E$ .

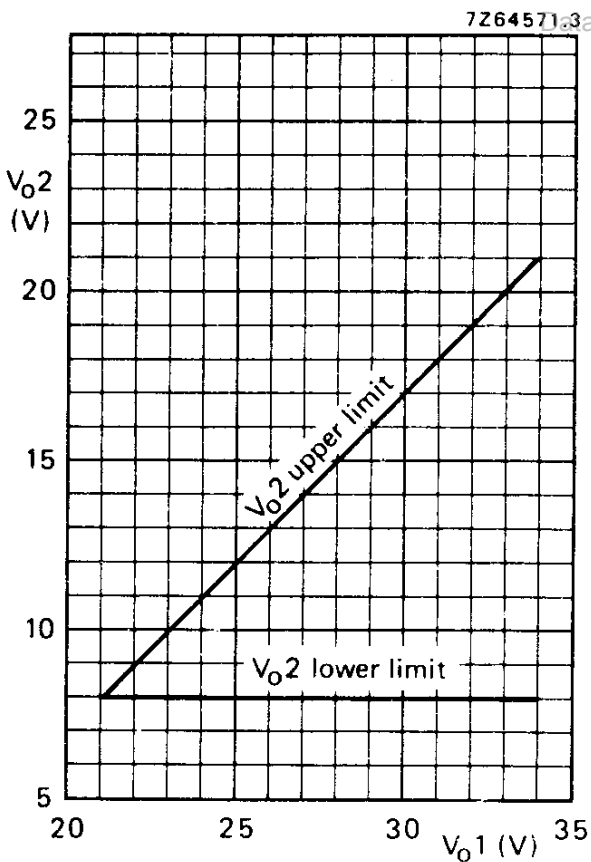

Fig. 6 Range of values for  $V_{O2}$ .

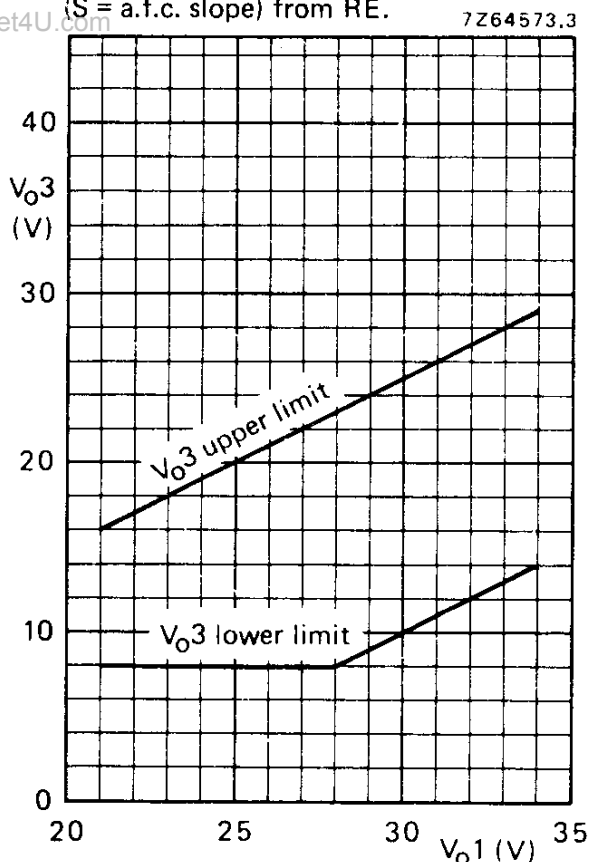

Fig. 7 Range of values for  $V_{O3}$ .

148



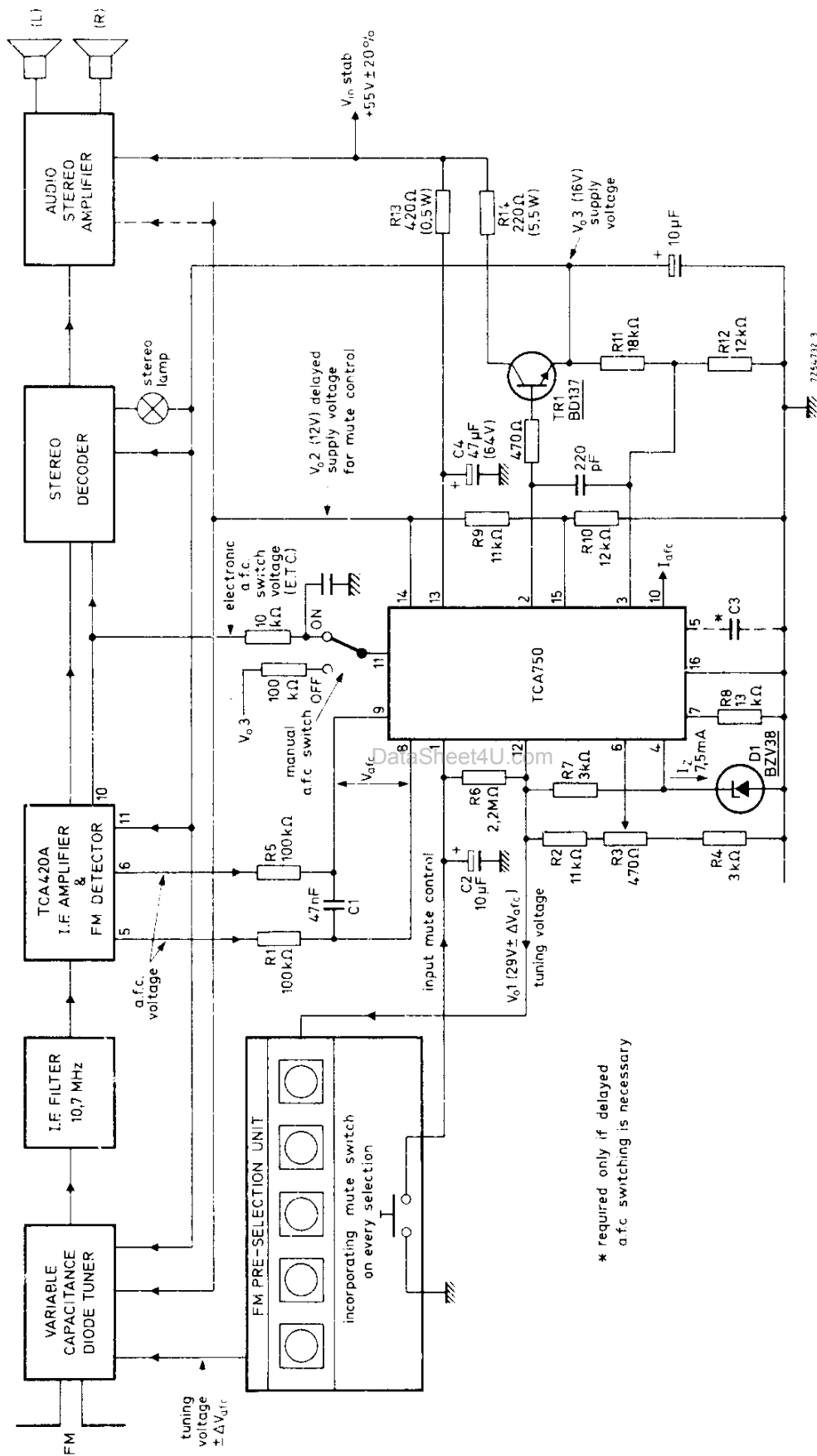

Fig. 8 Hi-fi radio receiver with electronic tuning using TCA750.

\* required only if delayed a.f.c. switching is necessary

