

TL431 Precision Programmable Reference

Check for Samples: [TL431](#), [TL431A](#), [TL431B](#), [TL432](#), [TL432A](#), [TL432B](#)

FEATURES

- Operation From -40°C to 125°C
- Reference Voltage Tolerance at 25°C
 - 0.5% . . . B Grade
 - 1% . . . A Grade
 - 2% . . . Standard Grade
- Typical Temperature Drift (TL431B)
 - 6 mV (C Temp)
 - 14 mV (I Temp, Q Temp)
- Low Output Noise
- 0.2- Ω Typical Output Impedance
- Sink-Current Capability . . . 1 mA to 100 mA
- Adjustable Output Voltage . . . Vref to 36 V

DESCRIPTION

The TL431 and TL432 are three-terminal adjustable shunt regulators, with specified thermal stability over applicable automotive, commercial, and military temperature ranges. The output voltage can be set to any value between Vref (approximately 2.5 V) and 36 V, with two external resistors (see [Figure 17](#)). These devices have a typical output impedance of 0.2 Ω . Active output circuitry provides a very sharp turn-on characteristic, making these devices excellent replacements for Zener diodes in many applications, such as onboard regulation, adjustable power supplies, and switching power supplies. The TL432 has exactly the same functionality and electrical specifications as the TL431, but has different pinouts for the DBV, DBZ, and PK packages.

Both the TL431 and TL432 devices are offered in three grades, with initial tolerances (at 25°C) of 0.5%, 1%, and 2%, for the B, A, and standard grade, respectively. In addition, low output drift vs temperature ensures good stability over the entire temperature range.

The TL43xxC devices are characterized for operation from 0°C to 70°C , the TL43xxI devices are characterized for operation from -40°C to 85°C , and the TL43xxQ devices are characterized for operation from -40°C to 125°C .



Please be aware that an important notice concerning availability, standard warranty, and use in critical applications of Texas Instruments semiconductor products and disclaimers thereto appears at the end of this data sheet.

TL431, TL431A, TL431B, TL432, TL432A, TL432B

SLVS543N – AUGUST 2004 – REVISED JANUARY 2014

www.ti.com

TL431, TL431A, TL431B . . . D (SOIC) PACKAGE
(TOP VIEW)

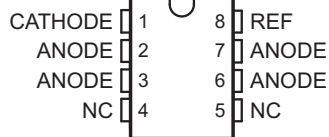

NC – No internal connection

TL431, TL431A, TL431B . . . P (PDIP), PS (SOP),
OR PW (TSSOP) PACKAGE
(TOP VIEW)

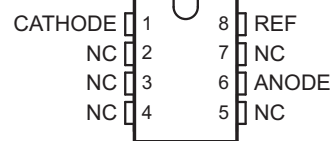

NC – No internal connection

TL431, TL431A, TL431B . . . PK (SOT-89) PACKAGE
(TOP VIEW)

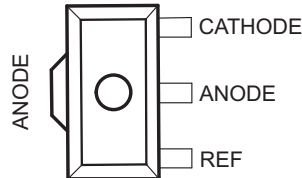

TL432, TL432A, TL432B . . . PK (SOT-89) PACKAGE
(TOP VIEW)

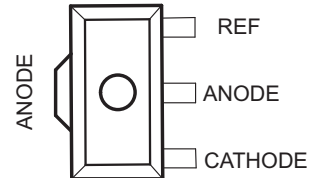

TL431, TL431A, TL431B . . . DBV (SOT-23-5) PACKAGE
(TOP VIEW)

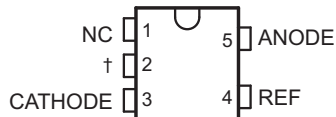

NC – No internal connection

† Pin 2 is attached to Substrate and must be connected to ANODE or left open.

TL432, TL432A, TL432B . . . DBV (SOT-23-5) PACKAGE
(TOP VIEW)

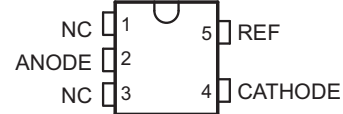

NC – No internal connection

TL431, TL431A, TL431B . . . DBZ (SOT-23-3) PACKAGE
(TOP VIEW)

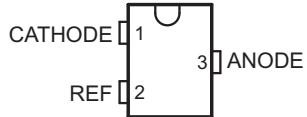

TL432, TL432A, TL432B . . . DBZ (SOT-23-3) PACKAGE
(TOP VIEW)

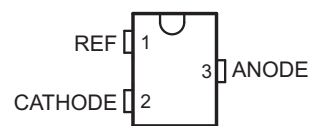

TL431, TL431A, TL431B . . . LP (TO-92/TO-226) PACKAGE
(TOP VIEW)

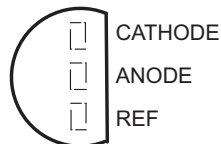

TL431A, TL431B . . . DCK (SC-70) PACKAGE
(TOP VIEW)

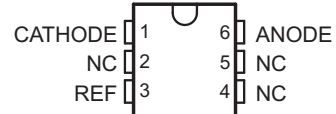

NC – No internal connection

TL431 . . . KTP (PowerFLEX /TO-252) PACKAGE
(TOP VIEW)

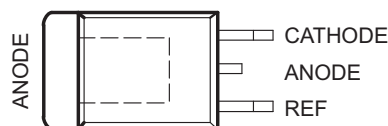

Symbol

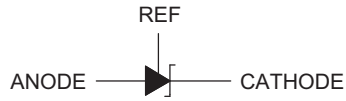

Functional Block Diagram

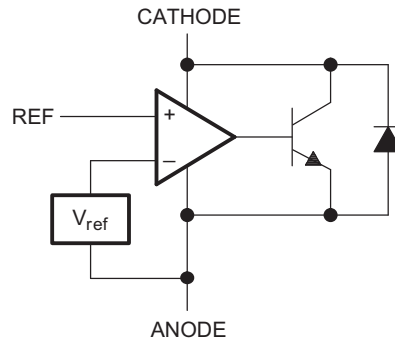

Equivalent Schematic

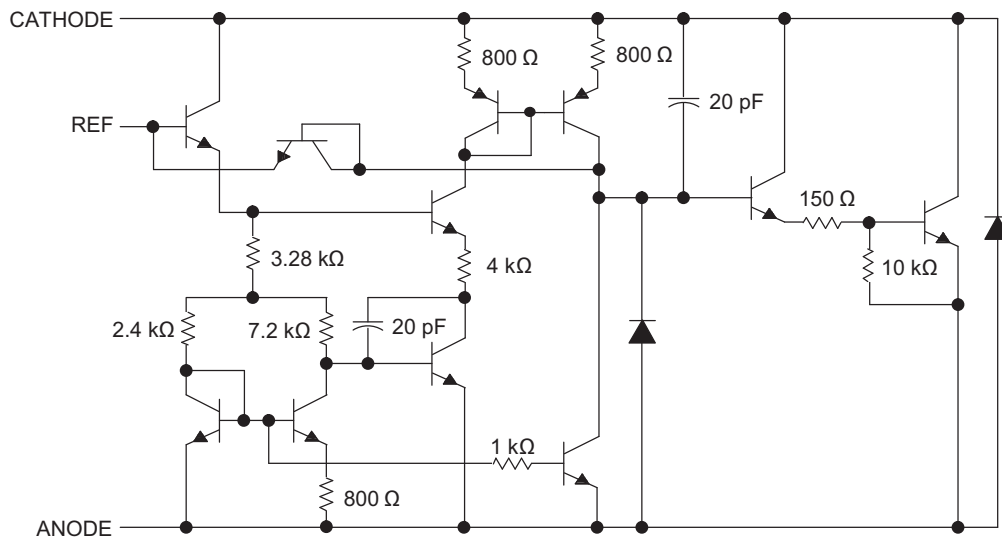

NOTE: All component values are nominal.

TL431, TL431A, TL431B, TL432, TL432A, TL432B

SLVS543N – AUGUST 2004 – REVISED JANUARY 2014

www.ti.com

Absolute Maximum Ratings⁽¹⁾

over operating free-air temperature range (unless otherwise noted)

		MIN	MAX	UNIT
V_{KA}	Cathode voltage ⁽²⁾		37	V
I_{KA}	Continuous cathode current range	–100	150	mA
$I_{I(ref)}$	Reference input current range	–0.05	10	mA
T_J	Operating virtual junction temperature		150	°C
T_{stg}	Storage temperature range	–65	150	°C

- (1) Stresses beyond those listed under "absolute maximum ratings" may cause permanent damage to the device. These are stress ratings only, and functional operation of the device at these or any other conditions beyond those indicated under "recommended operating conditions" is not implied. Exposure to absolute-maximum-rated conditions for extended periods may affect device reliability.
- (2) All voltage values are with respect to ANODE, unless otherwise noted.

Package Thermal Data⁽¹⁾

PACKAGE	BOARD	θ_{JC}	θ_{JA}
PDIP (P)	High K, JESD 51-7	57°C/W	85°C/W
SC-70 (DCK)	High K, JESD 51-7	259°C/W	87°C/W
SOIC (D)	High K, JESD 51-7	39°C/W	97°C/W
SOP (PS)	High K, JESD 51-7	46°C/W	95°C/W
SOT-89 (PK)	High K, JESD 51-7	9°C/W	52°C/W
SOT-23-5 (DBV)	High K, JESD 51-7	131°C/W	206°C/W
SOT-23-3 (DBZ)	High K, JESD 51-7	76°C/W	206°C/W
TO-92 (LP)	High K, JESD 51-7	55°C/W	140°C/W
TSSOP (PW)	High K, JESD 51-7	65°C/W	149°C/W

- (1) Maximum power dissipation is a function of $T_{J(max)}$, θ_{JA} , and T_A . The maximum allowable power dissipation at any allowable ambient temperature is $P_D = (T_{J(max)} - T_A) / \theta_{JA}$. Operating at the absolute maximum T_J of 150°C can affect reliability.

Recommended Operating Conditions

		MIN	MAX	UNIT
V_{KA}	Cathode voltage	V_{ref}	36	V
I_{KA}	Cathode current	1	100	mA
T_A	Operating free-air temperature	TL43xxC	0	70
		TL43xxI	–40	85
		TL43xxQ	–40	125

Electrical Characteristics

over recommended operating conditions, $T_A = 25^\circ\text{C}$ (unless otherwise noted)

PARAMETER	TEST CIRCUIT	TEST CONDITIONS	TL431C, TL432C			UNIT	
			MIN	TYP	MAX		
V_{ref}	Reference voltage	Figure 1	$V_{\text{KA}} = V_{\text{ref}}, I_{\text{KA}} = 10 \text{ mA}$			mV	
$V_{\text{I(dev)}}$	Deviation of reference input voltage over full temperature range ⁽¹⁾	Figure 1	$V_{\text{KA}} = V_{\text{ref}}, I_{\text{KA}} = 10 \text{ mA},$	SOT23-3 and TL432 devices	6	16	mV
				All other devices	4	25	
$\frac{\Delta V_{\text{ref}}}{\Delta V_{\text{KA}}}$	Ratio of change in reference voltage to the change in cathode voltage	Figure 2	$I_{\text{KA}} = 10 \text{ mA}$	$\Delta V_{\text{KA}} = 10 \text{ V} - V_{\text{ref}}$	-1.4	-2.7	mV/V
				$\Delta V_{\text{KA}} = 36 \text{ V} - 10 \text{ V}$	-1	-2	
I_{ref}	Reference input current	Figure 2	$I_{\text{KA}} = 10 \text{ mA}, R_1 = 10 \text{ k}\Omega, R_2 = \infty$			μA	
$I_{\text{I(dev)}}$	Deviation of reference input current over full temperature range ⁽¹⁾	Figure 2	$I_{\text{KA}} = 10 \text{ mA}, R_1 = 10 \text{ k}\Omega, R_2 = \infty$			μA	
I_{min}	Minimum cathode current for regulation	Figure 1	$V_{\text{KA}} = V_{\text{ref}}$			mA	
I_{off}	Off-state cathode current	Figure 3	$V_{\text{KA}} = 36 \text{ V}, V_{\text{ref}} = 0$			μA	
$ z_{\text{KA}} $	Dynamic impedance ⁽²⁾	Figure 1	$V_{\text{KA}} = V_{\text{ref}}, f \leq 1 \text{ kHz}, I_{\text{KA}} = 1 \text{ mA to } 100 \text{ mA}$			Ω	

(1) The deviation parameters $V_{\text{ref(dev)}}$ and $I_{\text{ref(dev)}}$ are defined as the differences between the maximum and minimum values obtained over the rated temperature range. The average full-range temperature coefficient of the reference input voltage $\alpha_{V_{\text{ref}}}$ is defined as:

$$\left| \alpha_{V_{\text{ref}}} \right| \left(\frac{\text{ppm}}{^\circ\text{C}} \right) = \frac{\left(\frac{V_{\text{I(dev)}}}{V_{\text{ref at } 25^\circ\text{C}}} \right) \times 10^6}{\Delta T_A}$$

where:

ΔT_A is the rated operating temperature range of the device.

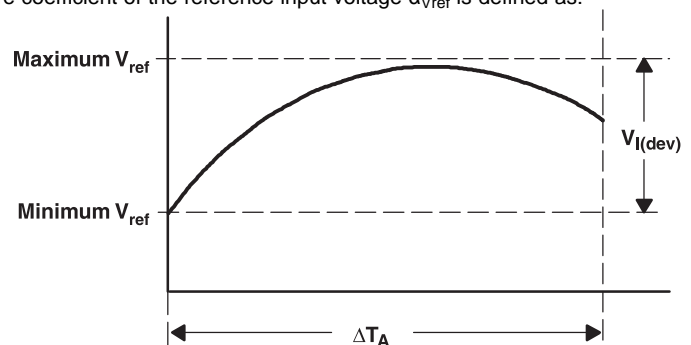

$\alpha_{V_{\text{ref}}}$ is positive or negative, depending on whether minimum V_{ref} or maximum V_{ref} , respectively, occurs at the lower temperature.

(2) The dynamic impedance is defined as: $|z_{\text{KA}}| = \frac{\Delta V_{\text{KA}}}{\Delta I_{\text{KA}}}$

When the device is operating with two external resistors (see Figure 2), the total dynamic impedance of the circuit is given by: $|z'| = \frac{\Delta V}{\Delta I}$ which is approximately equal to $|z_{\text{KA}}| \left(1 + \frac{R_1}{R_2} \right)$.

TL431, TL431A, TL431B, TL432, TL432A, TL432B

SLVS543N – AUGUST 2004 – REVISED JANUARY 2014

www.ti.com

Electrical Characteristics

over recommended operating conditions, $T_A = 25^\circ\text{C}$ (unless otherwise noted)

PARAMETER	TEST CIRCUIT	TEST CONDITIONS	TL431, TL432			UNIT	
			MIN	TYP	MAX		
V_{ref}	Reference voltage	Figure 1	$V_{\text{KA}} = V_{\text{ref}}, I_{\text{KA}} = 10 \text{ mA}$			mV	
$V_{\text{I(dev)}}$	Deviation of reference input voltage over full temperature range ⁽¹⁾	Figure 1	$V_{\text{KA}} = V_{\text{ref}}, I_{\text{KA}} = 10 \text{ mA}$	SOT23-3 and TL432 devices	14	34	mV
				All other devices	5	50	
$\frac{\Delta V_{\text{ref}}}{\Delta V_{\text{KA}}}$	Ratio of change in reference voltage to the change in cathode voltage	Figure 2	$I_{\text{KA}} = 10 \text{ mA}$	$\Delta V_{\text{KA}} = 10 \text{ V} - V_{\text{ref}}$	-1.4	-2.7	mV/V
				$\Delta V_{\text{KA}} = 36 \text{ V} - 10 \text{ V}$	-1	-2	
I_{ref}	Reference input current	Figure 2	$I_{\text{KA}} = 10 \text{ mA}, R_1 = 10 \text{ k}\Omega, R_2 = \infty$			μA	
$I_{\text{I(dev)}}$	Deviation of reference input current over full temperature range ⁽¹⁾	Figure 2	$I_{\text{KA}} = 10 \text{ mA}, R_1 = 10 \text{ k}\Omega, R_2 = \infty$			μA	
I_{min}	Minimum cathode current for regulation	Figure 1	$V_{\text{KA}} = V_{\text{ref}}$			mA	
I_{off}	Off-state cathode current	Figure 3	$V_{\text{KA}} = 36 \text{ V}, V_{\text{ref}} = 0$			μA	
$ z_{\text{KA}} $	Dynamic impedance ⁽²⁾	Figure 1	$V_{\text{KA}} = V_{\text{ref}}, f \leq 1 \text{ kHz}, I_{\text{KA}} = 1 \text{ mA to } 100 \text{ mA}$			Ω	

- (1) The deviation parameters $V_{\text{ref(dev)}}$ and $I_{\text{ref(dev)}}$ are defined as the differences between the maximum and minimum values obtained over the rated temperature range. The average full-range temperature coefficient of the reference input voltage $\alpha_{V_{\text{ref}}}$ is defined as:

$$\left| \alpha_{V_{\text{ref}}} \right| \left(\frac{\text{ppm}}{^\circ\text{C}} \right) = \frac{\left(\frac{V_{\text{I(dev)}}}{V_{\text{ref at } 25^\circ\text{C}}} \right) \times 10^6}{\Delta T_A}$$

where:

ΔT_A is the rated operating temperature range of the device.

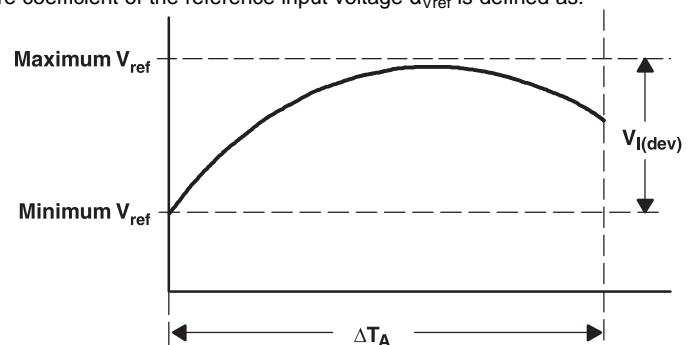

$\alpha_{V_{\text{ref}}}$ is positive or negative, depending on whether minimum V_{ref} or maximum V_{ref} , respectively, occurs at the lower temperature.

- (2) The dynamic impedance is defined as: $|z_{\text{KA}}| = \frac{\Delta V_{\text{KA}}}{\Delta I_{\text{KA}}}$

When the device is operating with two external resistors (see Figure 2), the total dynamic impedance of the circuit is given by: $|z'| = \frac{\Delta V}{\Delta I}$ which is approximately equal to $|z_{\text{KA}}| \left(1 + \frac{R_1}{R_2} \right)$.

Electrical Characteristics

over recommended operating conditions, $T_A = 25^\circ\text{C}$ (unless otherwise noted)

PARAMETER	TEST CIRCUIT	TEST CONDITIONS	TL431Q, TL432Q			UNIT	
			MIN	TYP	MAX		
V_{ref}	Reference voltage	Figure 1	$V_{\text{KA}} = V_{\text{ref}}, I_{\text{KA}} = 10 \text{ mA}$			mV	
$V_{\text{I(dev)}}$	Deviation of reference input voltage over full temperature range ⁽¹⁾	Figure 1	$V_{\text{KA}} = V_{\text{ref}}, I_{\text{KA}} = 10 \text{ mA}$			mV	
$\frac{\Delta V_{\text{ref}}}{\Delta V_{\text{KA}}}$	Ratio of change in reference voltage to the change in cathode voltage	Figure 2	$I_{\text{KA}} = 10 \text{ mA}$	$\Delta V_{\text{KA}} = 10 \text{ V} - V_{\text{ref}}$	-1.4	-2.7	mV/V
				$\Delta V_{\text{KA}} = 36 \text{ V} - 10 \text{ V}$	-1	-2	
I_{ref}	Reference input current	Figure 2	$I_{\text{KA}} = 10 \text{ mA}, R_1 = 10 \text{ k}\Omega, R_2 = \infty$			μA	
$I_{\text{I(dev)}}$	Deviation of reference input current over full temperature range ⁽¹⁾	Figure 2	$I_{\text{KA}} = 10 \text{ mA}, R_1 = 10 \text{ k}\Omega, R_2 = \infty$			μA	
I_{min}	Minimum cathode current for regulation	Figure 1	$V_{\text{KA}} = V_{\text{ref}}$			mA	
I_{off}	Off-state cathode current	Figure 3	$V_{\text{KA}} = 36 \text{ V}, V_{\text{ref}} = 0$			μA	
$ z_{\text{KA}} $	Dynamic impedance ⁽²⁾	Figure 1	$V_{\text{KA}} = V_{\text{ref}}, f \leq 1 \text{ kHz}, I_{\text{KA}} = 1 \text{ mA to } 100 \text{ mA}$			Ω	

- (1) The deviation parameters $V_{\text{ref(dev)}}$ and $I_{\text{ref(dev)}}$ are defined as the differences between the maximum and minimum values obtained over the rated temperature range. The average full-range temperature coefficient of the reference input voltage $\alpha_{V_{\text{ref}}}$ is defined as:

$$\left| \alpha_{V_{\text{ref}}} \right| \left(\frac{\text{ppm}}{^\circ\text{C}} \right) = \frac{\left(\frac{V_{\text{I(dev)}}}{V_{\text{ref at } 25^\circ\text{C}}} \right) \times 10^6}{\Delta T_A}$$

where:

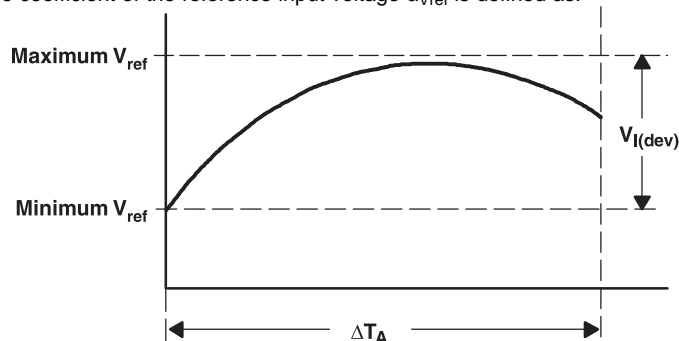
 ΔT_A is the rated operating temperature range of the device.

 $\alpha_{V_{\text{ref}}}$ is positive or negative, depending on whether minimum V_{ref} or maximum V_{ref} , respectively, occurs at the lower temperature.

- (2) The dynamic impedance is defined as: $|z_{\text{KA}}| = \frac{\Delta V_{\text{KA}}}{\Delta I_{\text{KA}}}$

When the device is operating with two external resistors (see Figure 2), the total dynamic impedance of the circuit is given by: $|z'| = \frac{\Delta V}{\Delta I}$ which is approximately equal to $|z_{\text{KA}}| \left(1 + \frac{R_1}{R_2} \right)$.

TL431, TL431A, TL431B, TL432, TL432A, TL432B

SLVS543N – AUGUST 2004 – REVISED JANUARY 2014

www.ti.com

Electrical Characteristics

over recommended operating conditions, $T_A = 25^\circ\text{C}$ (unless otherwise noted)

PARAMETER	TEST CIRCUIT	TEST CONDITIONS	TL431AC, TL432AC			UNIT	
			MIN	TYP	MAX		
V_{ref}	Reference voltage	Figure 1	$V_{\text{KA}} = V_{\text{ref}}, I_{\text{KA}} = 10 \text{ mA}$			mV	
$V_{\text{I(dev)}}$	Deviation of reference input voltage over full temperature range ⁽¹⁾	Figure 1	$V_{\text{KA}} = V_{\text{ref}}, I_{\text{KA}} = 10 \text{ mA}$	SOT23-3 and TL432 devices	6	16	mV
				All other devices	4	25	
$\frac{\Delta V_{\text{ref}}}{\Delta V_{\text{KA}}}$	Ratio of change in reference voltage to the change in cathode voltage	Figure 2	$I_{\text{KA}} = 10 \text{ mA}$	$\Delta V_{\text{KA}} = 10 \text{ V} - V_{\text{ref}}$	-1.4	-2.7	mV/V
				$\Delta V_{\text{KA}} = 36 \text{ V} - 10 \text{ V}$	-1	-2	
I_{ref}	Reference input current	Figure 2	$I_{\text{KA}} = 10 \text{ mA}, R_1 = 10 \text{ k}\Omega, R_2 = \infty$			μA	
$I_{\text{I(dev)}}$	Deviation of reference input current over full temperature range ⁽¹⁾	Figure 2	$I_{\text{KA}} = 10 \text{ mA}, R_1 = 10 \text{ k}\Omega, R_2 = \infty$			μA	
I_{min}	Minimum cathode current for regulation	Figure 1	$V_{\text{KA}} = V_{\text{ref}}$			mA	
I_{off}	Off-state cathode current	Figure 3	$V_{\text{KA}} = 36 \text{ V}, V_{\text{ref}} = 0$			μA	
$ z_{\text{KA}} $	Dynamic impedance ⁽²⁾	Figure 1	$V_{\text{KA}} = V_{\text{ref}}, f \leq 1 \text{ kHz}, I_{\text{KA}} = 1 \text{ mA to } 100 \text{ mA}$			Ω	

(1) The deviation parameters $V_{\text{ref(dev)}}$ and $I_{\text{ref(dev)}}$ are defined as the differences between the maximum and minimum values obtained over the rated temperature range. The average full-range temperature coefficient of the reference input voltage $\alpha_{V_{\text{ref}}}$ is defined as:

$$\left| \alpha_{V_{\text{ref}}} \right| \left(\frac{\text{ppm}}{^\circ\text{C}} \right) = \frac{\left(\frac{V_{\text{I(dev)}}}{V_{\text{ref at } 25^\circ\text{C}}} \right) \times 10^6}{\Delta T_A}$$

where:

ΔT_A is the rated operating temperature range of the device.

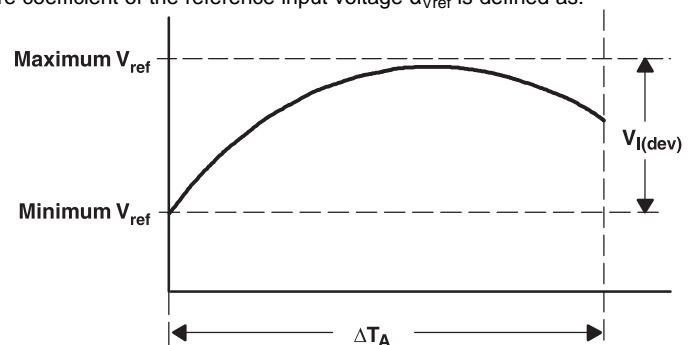

$\alpha_{V_{\text{ref}}}$ is positive or negative, depending on whether minimum V_{ref} or maximum V_{ref} , respectively, occurs at the lower temperature.

(2) The dynamic impedance is defined as: $|z_{\text{KA}}| = \frac{\Delta V_{\text{KA}}}{\Delta I_{\text{KA}}}$

When the device is operating with two external resistors (see Figure 2), the total dynamic impedance of the circuit is given by: $|z'| = \frac{\Delta V}{\Delta I}$ which is approximately equal to $|z_{\text{KA}}| \left(1 + \frac{R_1}{R_2} \right)$.

Electrical Characteristics

over recommended operating conditions, $T_A = 25^\circ\text{C}$ (unless otherwise noted)

PARAMETER	TEST CIRCUIT	TEST CONDITIONS	TL431AI, TL432AI			UNIT	
			MIN	TYP	MAX		
V_{ref}	Reference voltage	Figure 1	$V_{\text{KA}} = V_{\text{ref}}, I_{\text{KA}} = 10 \text{ mA}$			mV	
$V_{\text{I(dev)}}$	Deviation of reference input voltage over full temperature range ⁽¹⁾	Figure 1	$V_{\text{KA}} = V_{\text{ref}}, I_{\text{KA}} = 10 \text{ mA}$	SOT23-3 and TL432 devices	14	34	mV
				All other devices	5	50	
$\frac{\Delta V_{\text{ref}}}{\Delta V_{\text{KA}}}$	Ratio of change in reference voltage to the change in cathode voltage	Figure 2	$I_{\text{KA}} = 10 \text{ mA}$	$\Delta V_{\text{KA}} = 10 \text{ V} - V_{\text{ref}}$	-1.4	-2.7	mV/V
				$\Delta V_{\text{KA}} = 36 \text{ V} - 10 \text{ V}$	-1	-2	
I_{ref}	Reference input current	Figure 2	$I_{\text{KA}} = 10 \text{ mA}, R_1 = 10 \text{ k}\Omega, R_2 = \infty$			μA	
$I_{\text{I(dev)}}$	Deviation of reference input current over full temperature range ⁽¹⁾	Figure 2	$I_{\text{KA}} = 10 \text{ mA}, R_1 = 10 \text{ k}\Omega, R_2 = \infty$			μA	
I_{min}	Minimum cathode current for regulation	Figure 1	$V_{\text{KA}} = V_{\text{ref}}$			mA	
I_{off}	Off-state cathode current	Figure 3	$V_{\text{KA}} = 36 \text{ V}, V_{\text{ref}} = 0$			μA	
$ z_{\text{KA}} $	Dynamic impedance ⁽²⁾	Figure 1	$V_{\text{KA}} = V_{\text{ref}}, f \leq 1 \text{ kHz}, I_{\text{KA}} = 1 \text{ mA to } 100 \text{ mA}$			Ω	

- (1) The deviation parameters $V_{\text{ref(dev)}}$ and $I_{\text{ref(dev)}}$ are defined as the differences between the maximum and minimum values obtained over the rated temperature range. The average full-range temperature coefficient of the reference input voltage $\alpha_{V_{\text{ref}}}$ is defined as:

$$\left| \alpha_{V_{\text{ref}}} \right| \left(\frac{\text{ppm}}{^\circ\text{C}} \right) = \frac{\left(\frac{V_{\text{I(dev)}}}{V_{\text{ref at } 25^\circ\text{C}}} \right) \times 10^6}{\Delta T_A}$$

where:

ΔT_A is the rated operating temperature range of the device.

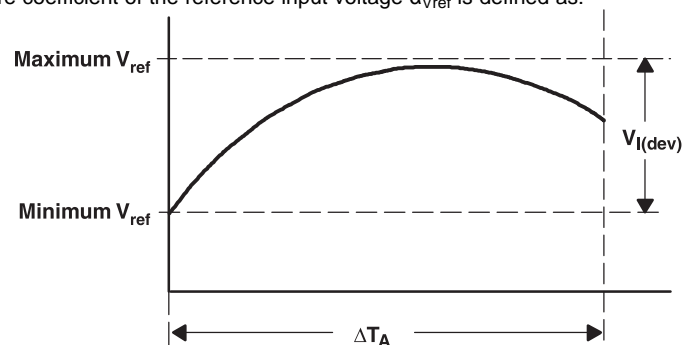

$\alpha_{V_{\text{ref}}}$ is positive or negative, depending on whether minimum V_{ref} or maximum V_{ref} , respectively, occurs at the lower temperature.

- (2) The dynamic impedance is defined as: $|z_{\text{KA}}| = \frac{\Delta V_{\text{KA}}}{\Delta I_{\text{KA}}}$

When the device is operating with two external resistors (see Figure 2), the total dynamic impedance of the circuit is given by: $|z'| = \frac{\Delta V}{\Delta I}$ which is approximately equal to $|z_{\text{KA}}| \left(1 + \frac{R_1}{R_2} \right)$.

Electrical Characteristics

 over recommended operating conditions, $T_A = 25^\circ\text{C}$ (unless otherwise noted)

PARAMETER	TEST CIRCUIT	TEST CONDITIONS	TL431AQ, TL432AQ			UNIT	
			MIN	TYP	MAX		
V_{ref}	Reference voltage	Figure 1	$V_{\text{KA}} = V_{\text{ref}}, I_{\text{KA}} = 10 \text{ mA}$			mV	
$V_{\text{I(dev)}}$	Deviation of reference input voltage over full temperature range ⁽¹⁾	Figure 1	$V_{\text{KA}} = V_{\text{ref}}, I_{\text{KA}} = 10 \text{ mA}$			mV	
$\frac{\Delta V_{\text{ref}}}{\Delta V_{\text{KA}}}$	Ratio of change in reference voltage to the change in cathode voltage	Figure 2	$I_{\text{KA}} = 10 \text{ mA}$	$\Delta V_{\text{KA}} = 10 \text{ V} - V_{\text{ref}}$	-1.4	-2.7	mV/V
				$\Delta V_{\text{KA}} = 36 \text{ V} - 10 \text{ V}$	-1	-2	
I_{ref}	Reference input current	Figure 2	$I_{\text{KA}} = 10 \text{ mA}, R_1 = 10 \text{ k}\Omega, R_2 = \infty$			μA	
$I_{\text{I(dev)}}$	Deviation of reference input current over full temperature range ⁽¹⁾	Figure 2	$I_{\text{KA}} = 10 \text{ mA}, R_1 = 10 \text{ k}\Omega, R_2 = \infty$			μA	
I_{min}	Minimum cathode current for regulation	Figure 1	$V_{\text{KA}} = V_{\text{ref}}$			mA	
I_{off}	Off-state cathode current	Figure 3	$V_{\text{KA}} = 36 \text{ V}, V_{\text{ref}} = 0$			μA	
$ z_{\text{KA}} $	Dynamic impedance ⁽²⁾	Figure 1	$V_{\text{KA}} = V_{\text{ref}}, f \leq 1 \text{ kHz}, I_{\text{KA}} = 1 \text{ mA to } 100 \text{ mA}$			Ω	

- (1) The deviation parameters $V_{\text{ref(dev)}}$ and $I_{\text{ref(dev)}}$ are defined as the differences between the maximum and minimum values obtained over the rated temperature range. The average full-range temperature coefficient of the reference input voltage $\alpha_{V_{\text{ref}}}$ is defined as:

$$\left| \alpha_{V_{\text{ref}}} \right| \left(\frac{\text{ppm}}{^\circ\text{C}} \right) = \frac{\left(\frac{V_{\text{I(dev)}}}{V_{\text{ref at } 25^\circ\text{C}}} \right) \times 10^6}{\Delta T_A}$$

where:

ΔT_A is the rated operating temperature range of the device.

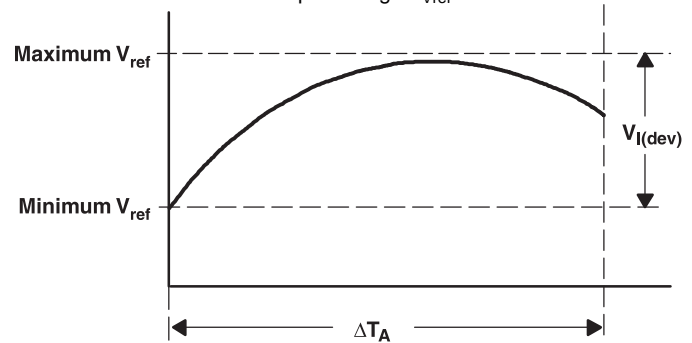

$\alpha_{V_{\text{ref}}}$ is positive or negative, depending on whether minimum V_{ref} or maximum V_{ref} , respectively, occurs at the lower temperature.

- (2) The dynamic impedance is defined as: $|z_{\text{KA}}| = \frac{\Delta V_{\text{KA}}}{\Delta I_{\text{KA}}}$

When the device is operating with two external resistors (see Figure 2), the total dynamic impedance of the circuit is given by: $|z'| = \frac{\Delta V}{\Delta I}$ which is approximately equal to $|z_{\text{KA}}| \left(1 + \frac{R_1}{R_2} \right)$.

Electrical Characteristics

over recommended operating conditions, $T_A = 25^\circ\text{C}$ (unless otherwise noted)

PARAMETER	TEST CIRCUIT	TEST CONDITIONS	TL431BC, TL432BC			UNIT	
			MIN	TYP	MAX		
V_{ref}	Reference voltage	Figure 1	$V_{\text{KA}} = V_{\text{ref}}, I_{\text{KA}} = 10 \text{ mA}$			mV	
$V_{\text{I(dev)}}$	Deviation of reference input voltage over full temperature range ⁽¹⁾	Figure 1	$V_{\text{KA}} = V_{\text{ref}}, I_{\text{KA}} = 10 \text{ mA}$			mV	
$\frac{\Delta V_{\text{ref}}}{\Delta V_{\text{KA}}}$	Ratio of change in reference voltage to the change in cathode voltage	Figure 2	$I_{\text{KA}} = 10 \text{ mA}$	$\Delta V_{\text{KA}} = 10 \text{ V} - V_{\text{ref}}$	-1.4	-2.7	mV/V
				$\Delta V_{\text{KA}} = 36 \text{ V} - 10 \text{ V}$	-1	-2	
I_{ref}	Reference input current	Figure 2	$I_{\text{KA}} = 10 \text{ mA}, R_1 = 10 \text{ k}\Omega, R_2 = \infty$			μA	
$I_{\text{I(dev)}}$	Deviation of reference input current over full temperature range ⁽¹⁾	Figure 2	$I_{\text{KA}} = 10 \text{ mA}, R_1 = 10 \text{ k}\Omega, R_2 = \infty$			μA	
I_{min}	Minimum cathode current for regulation	Figure 1	$V_{\text{KA}} = V_{\text{ref}}$			mA	
I_{off}	Off-state cathode current	Figure 3	$V_{\text{KA}} = 36 \text{ V}, V_{\text{ref}} = 0$			μA	
$ z_{\text{KA}} $	Dynamic impedance ⁽²⁾	Figure 1	$V_{\text{KA}} = V_{\text{ref}}, f \leq 1 \text{ kHz}, I_{\text{KA}} = 1 \text{ mA to } 100 \text{ mA}$			Ω	

- (1) The deviation parameters $V_{\text{ref(dev)}}$ and $I_{\text{ref(dev)}}$ are defined as the differences between the maximum and minimum values obtained over the rated temperature range. The average full-range temperature coefficient of the reference input voltage $\alpha_{V_{\text{ref}}}$ is defined as:

$$\left| \alpha_{V_{\text{ref}}} \right| \left(\frac{\text{ppm}}{^\circ\text{C}} \right) = \frac{\left(\frac{V_{\text{I(dev)}}}{V_{\text{ref at } 25^\circ\text{C}}} \right) \times 10^6}{\Delta T_A}$$

where:

ΔT_A is the rated operating temperature range of the device.

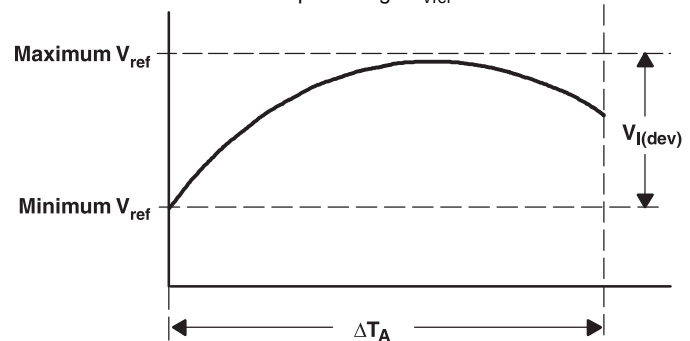

$\alpha_{V_{\text{ref}}}$ is positive or negative, depending on whether minimum V_{ref} or maximum V_{ref} , respectively, occurs at the lower temperature.

- (2) The dynamic impedance is defined as: $|z_{\text{KA}}| = \frac{\Delta V_{\text{KA}}}{\Delta I_{\text{KA}}}$

When the device is operating with two external resistors (see Figure 2), the total dynamic impedance of the circuit is given by: $|z'| = \frac{\Delta V}{\Delta I}$ which is approximately equal to $|z_{\text{KA}}| \left(1 + \frac{R_1}{R_2} \right)$.

Electrical Characteristics

 over recommended operating conditions, $T_A = 25^\circ\text{C}$ (unless otherwise noted)

PARAMETER	TEST CIRCUIT	TEST CONDITIONS	TL431BI, TL432BI			UNIT	
			MIN	TYP	MAX		
V_{ref}	Reference voltage	Figure 1	$V_{\text{KA}} = V_{\text{ref}}, I_{\text{KA}} = 10 \text{ mA}$			mV	
$V_{\text{I(dev)}}$	Deviation of reference input voltage over full temperature range ⁽¹⁾	Figure 1	$V_{\text{KA}} = V_{\text{ref}}, I_{\text{KA}} = 10 \text{ mA}$			mV	
$\frac{\Delta V_{\text{ref}}}{\Delta V_{\text{KA}}}$	Ratio of change in reference voltage to the change in cathode voltage	Figure 2	$I_{\text{KA}} = 10 \text{ mA}$	$\Delta V_{\text{KA}} = 10 \text{ V} - V_{\text{ref}}$	-1.4	-2.7	mV/V
				$\Delta V_{\text{KA}} = 36 \text{ V} - 10 \text{ V}$	-1	-2	
I_{ref}	Reference input current	Figure 2	$I_{\text{KA}} = 10 \text{ mA}, R_1 = 10 \text{ k}\Omega, R_2 = \infty$			μA	
$I_{\text{I(dev)}}$	Deviation of reference input current over full temperature range ⁽¹⁾	Figure 2	$I_{\text{KA}} = 10 \text{ mA}, R_1 = 10 \text{ k}\Omega, R_2 = \infty$			μA	
I_{min}	Minimum cathode current for regulation	Figure 1	$V_{\text{KA}} = V_{\text{ref}}$			mA	
I_{off}	Off-state cathode current	Figure 3	$V_{\text{KA}} = 36 \text{ V}, V_{\text{ref}} = 0$			μA	
$ z_{\text{KA}} $	Dynamic impedance ⁽²⁾	Figure 1	$V_{\text{KA}} = V_{\text{ref}}, f \leq 1 \text{ kHz}, I_{\text{KA}} = 1 \text{ mA to } 100 \text{ mA}$			Ω	

- (1) The deviation parameters $V_{\text{ref(dev)}}$ and $I_{\text{ref(dev)}}$ are defined as the differences between the maximum and minimum values obtained over the rated temperature range. The average full-range temperature coefficient of the reference input voltage $\alpha_{V_{\text{ref}}}$ is defined as:

$$\left| \alpha_{V_{\text{ref}}} \right| \left(\frac{\text{ppm}}{^\circ\text{C}} \right) = \frac{\left(\frac{V_{\text{I(dev)}}}{V_{\text{ref at } 25^\circ\text{C}}} \right) \times 10^6}{\Delta T_A}$$

where:

ΔT_A is the rated operating temperature range of the device.

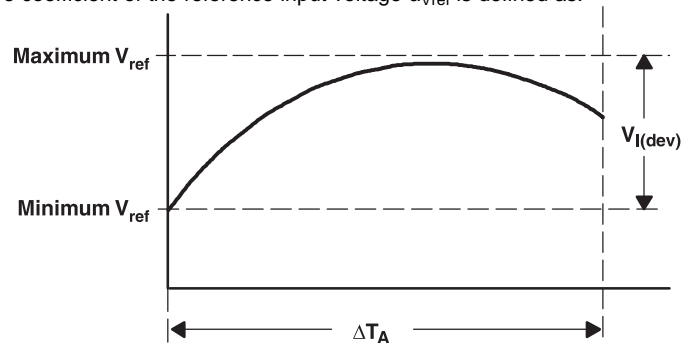

$\alpha_{V_{\text{ref}}}$ is positive or negative, depending on whether minimum V_{ref} or maximum V_{ref} , respectively, occurs at the lower temperature.

- (2) The dynamic impedance is defined as: $|z_{\text{KA}}| = \frac{\Delta V_{\text{KA}}}{\Delta I_{\text{KA}}}$

When the device is operating with two external resistors (see Figure 2), the total dynamic impedance of the circuit is given by: $|z'| = \frac{\Delta V}{\Delta I}$ which is approximately equal to $|z_{\text{KA}}| \left(1 + \frac{R_1}{R_2} \right)$.

Electrical Characteristics

 over recommended operating conditions, $T_A = 25^\circ\text{C}$ (unless otherwise noted)

PARAMETER	TEST CIRCUIT	TEST CONDITIONS	TL431BQ, TL432BQ			UNIT	
			MIN	TYP	MAX		
V_{ref}	Reference voltage	Figure 1	$V_{\text{KA}} = V_{\text{ref}}, I_{\text{KA}} = 10 \text{ mA}$			mV	
$V_{\text{I(dev)}}$	Deviation of reference input voltage over full temperature range ⁽¹⁾	Figure 1	$V_{\text{KA}} = V_{\text{ref}}, I_{\text{KA}} = 10 \text{ mA}$			mV	
$\frac{\Delta V_{\text{ref}}}{\Delta V_{\text{KA}}}$	Ratio of change in reference voltage to the change in cathode voltage	Figure 2	$I_{\text{KA}} = 10 \text{ mA}$	$\Delta V_{\text{KA}} = 10 \text{ V} - V_{\text{ref}}$	-1.4	-2.7	mV/V
				$\Delta V_{\text{KA}} = 36 \text{ V} - 10 \text{ V}$	-1	-2	
I_{ref}	Reference input current	Figure 2	$I_{\text{KA}} = 10 \text{ mA}, R_1 = 10 \text{ k}\Omega, R_2 = \infty$			μA	
$I_{\text{I(dev)}}$	Deviation of reference input current over full temperature range ⁽¹⁾	Figure 2	$I_{\text{KA}} = 10 \text{ mA}, R_1 = 10 \text{ k}\Omega, R_2 = \infty$			μA	
I_{min}	Minimum cathode current for regulation	Figure 1	$V_{\text{KA}} = V_{\text{ref}}$			mA	
I_{off}	Off-state cathode current	Figure 3	$V_{\text{KA}} = 36 \text{ V}, V_{\text{ref}} = 0$			μA	
$ z_{\text{KA}} $	Dynamic impedance ⁽²⁾	Figure 1	$V_{\text{KA}} = V_{\text{ref}}, f \leq 1 \text{ kHz}, I_{\text{KA}} = 1 \text{ mA to } 100 \text{ mA}$			Ω	

- (1) The deviation parameters $V_{\text{ref(dev)}}$ and $I_{\text{ref(dev)}}$ are defined as the differences between the maximum and minimum values obtained over the rated temperature range. The average full-range temperature coefficient of the reference input voltage $\alpha_{V_{\text{ref}}}$ is defined as:

$$|\alpha_{V_{\text{ref}}}| \left(\frac{\text{ppm}}{^\circ\text{C}} \right) = \frac{\left(\frac{V_{\text{I(dev)}}}{V_{\text{ref at } 25^\circ\text{C}}} \right) \times 10^6}{\Delta T_A}$$

where:

ΔT_A is the rated operating temperature range of the device.

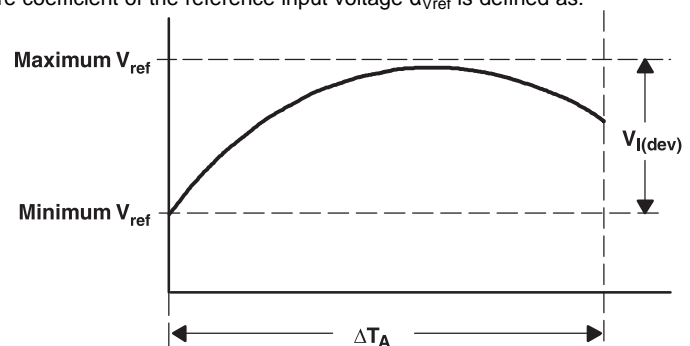

$\alpha_{V_{\text{ref}}}$ is positive or negative, depending on whether minimum V_{ref} or maximum V_{ref} , respectively, occurs at the lower temperature.

- (2) The dynamic impedance is defined as: $|z_{\text{KA}}| = \frac{\Delta V_{\text{KA}}}{\Delta I_{\text{KA}}}$

When the device is operating with two external resistors (see Figure 2), the total dynamic impedance of the circuit is given by: $|z'| = \frac{\Delta V}{\Delta I}$ which is approximately equal to $|z_{\text{KA}}| \left(1 + \frac{R_1}{R_2} \right)$.

Parameter Measurement Information

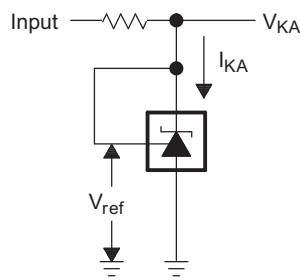

Figure 1. Test Circuit for $V_{KA} = V_{ref}$

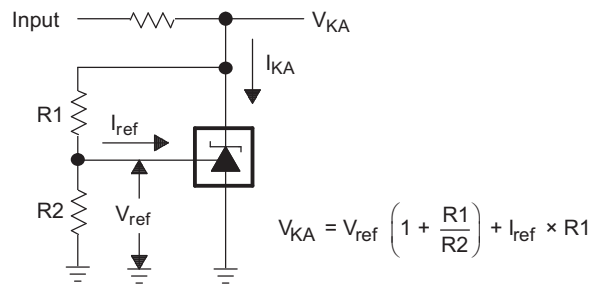

Figure 2. Test Circuit for $V_{KA} > V_{ref}$

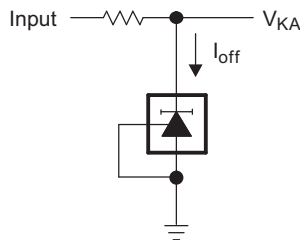

Figure 3. Test Circuit for I_{off}

Typical Characteristics

Data at high and low temperatures are applicable only within the recommended operating free-air temperature ranges of the various devices.

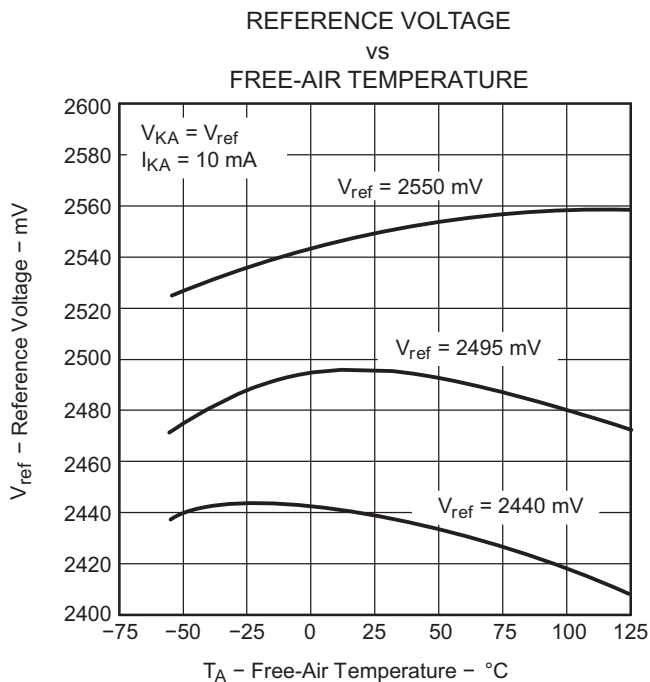

Figure 4.

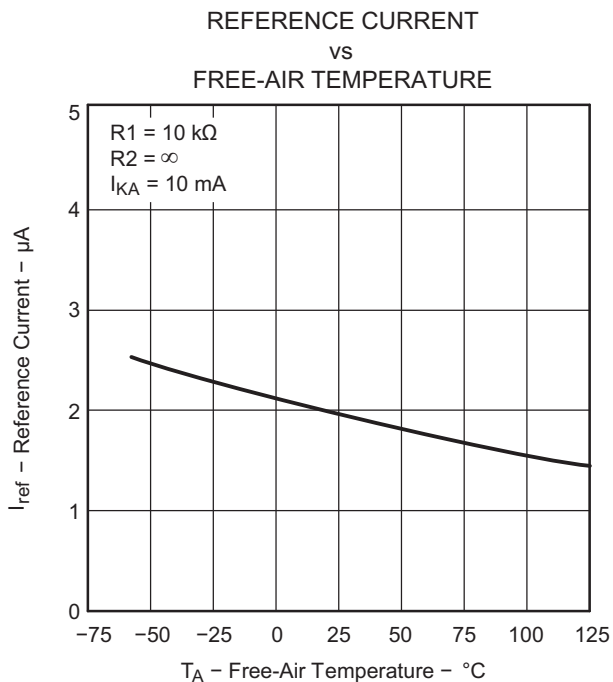

Figure 5.

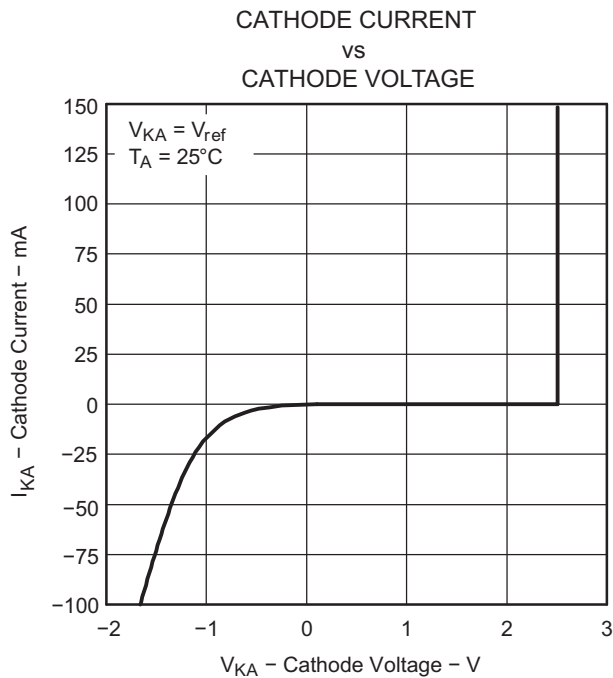

Figure 6.

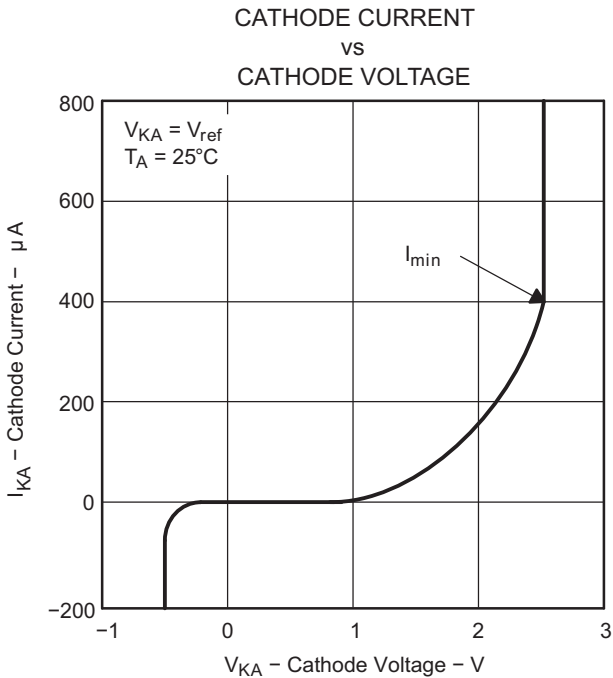

Figure 7.

Typical Characteristics (continued)

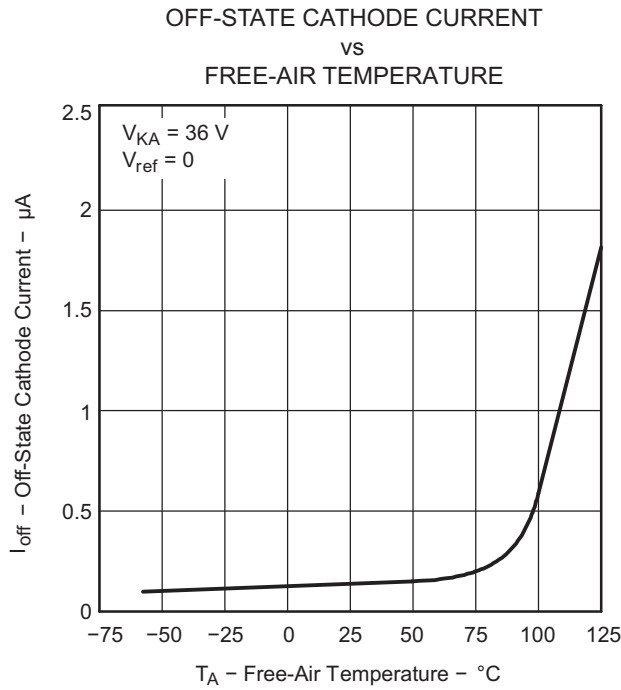

Figure 8.

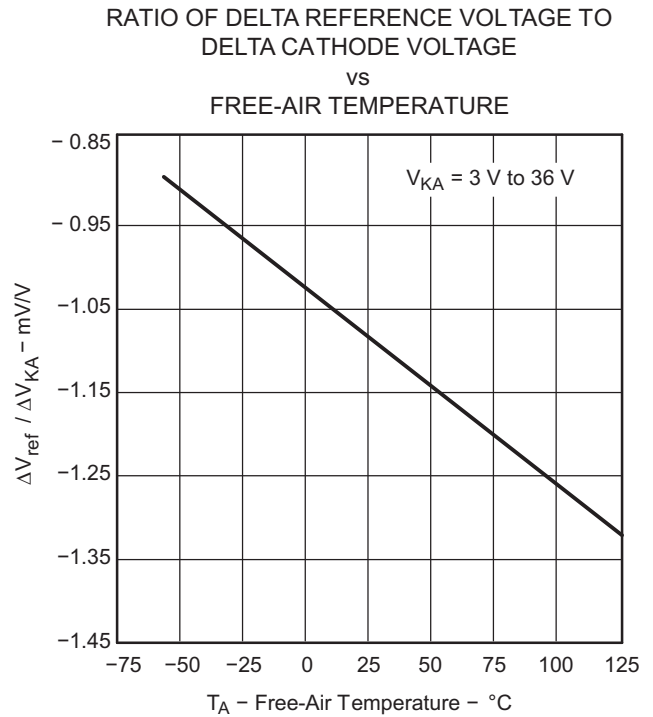

Figure 9.

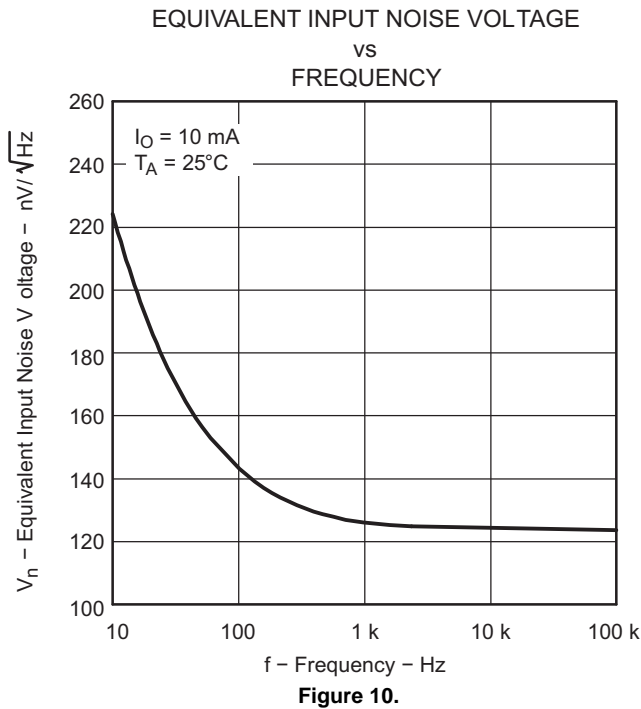

Figure 10.

Typical Characteristics (continued)

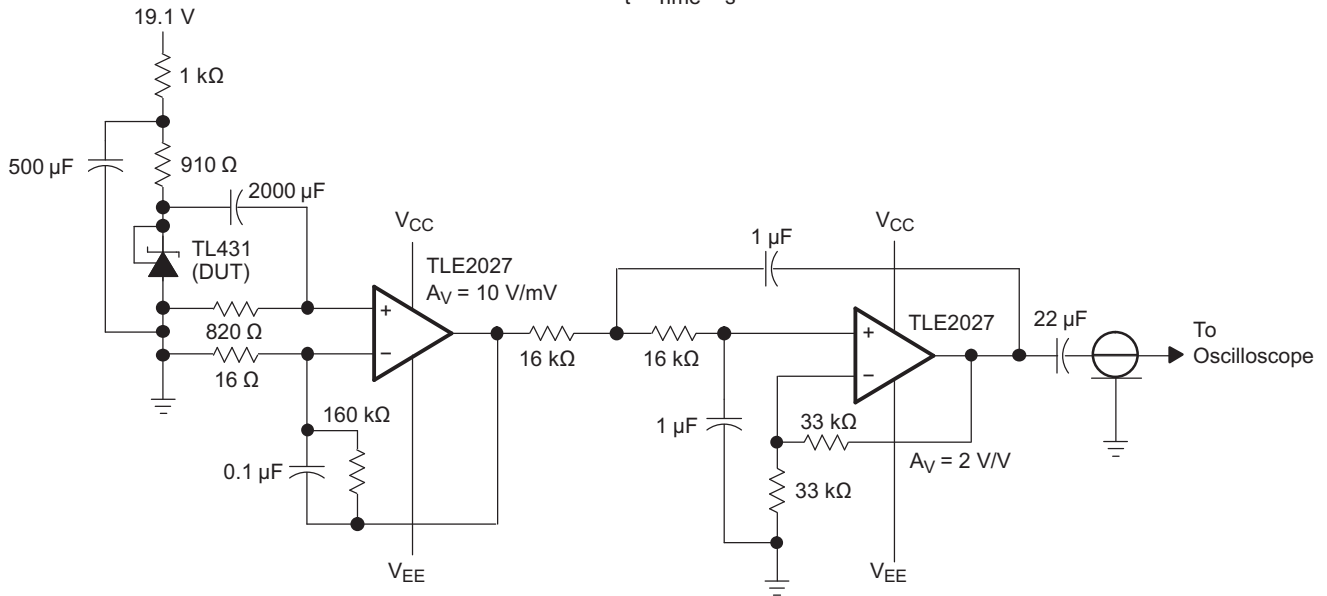
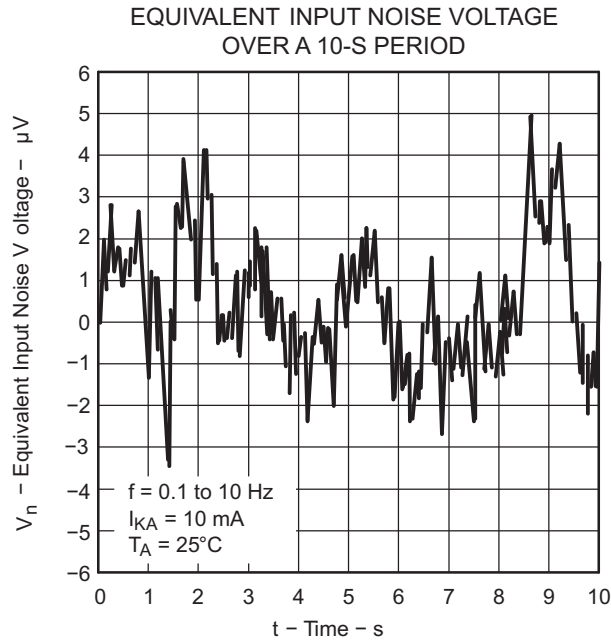

Figure 11.

Typical Characteristics (continued)

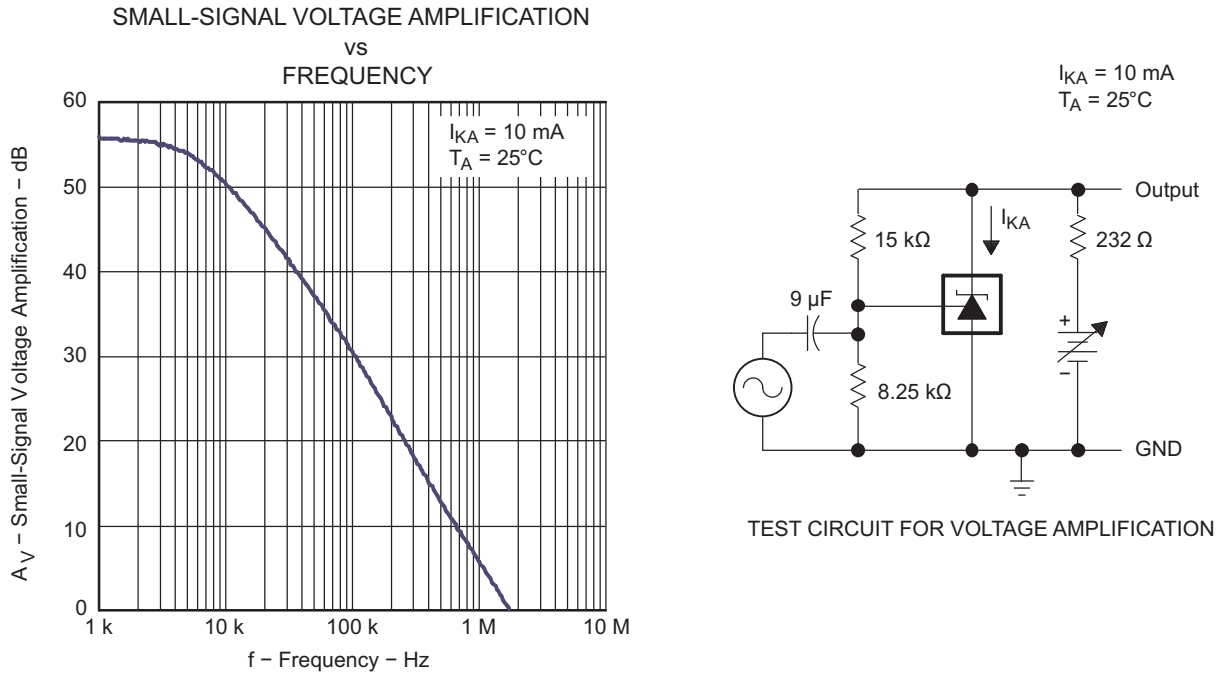

Figure 12.

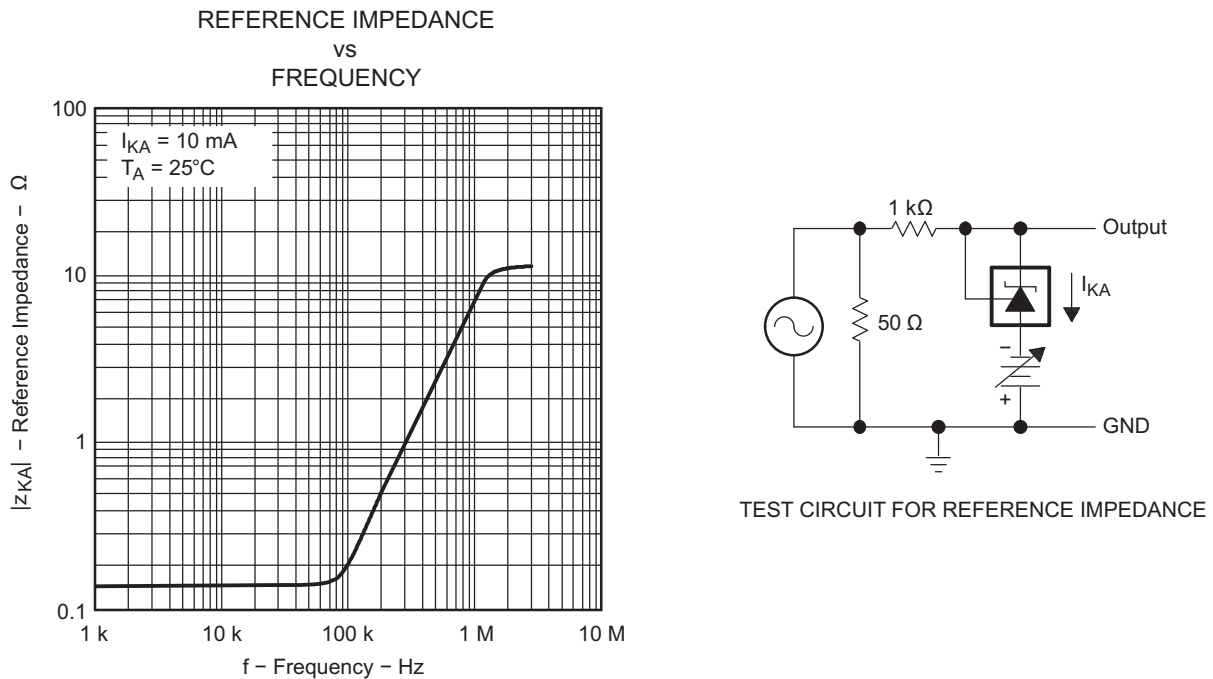

Figure 13.

Typical Characteristics (continued)

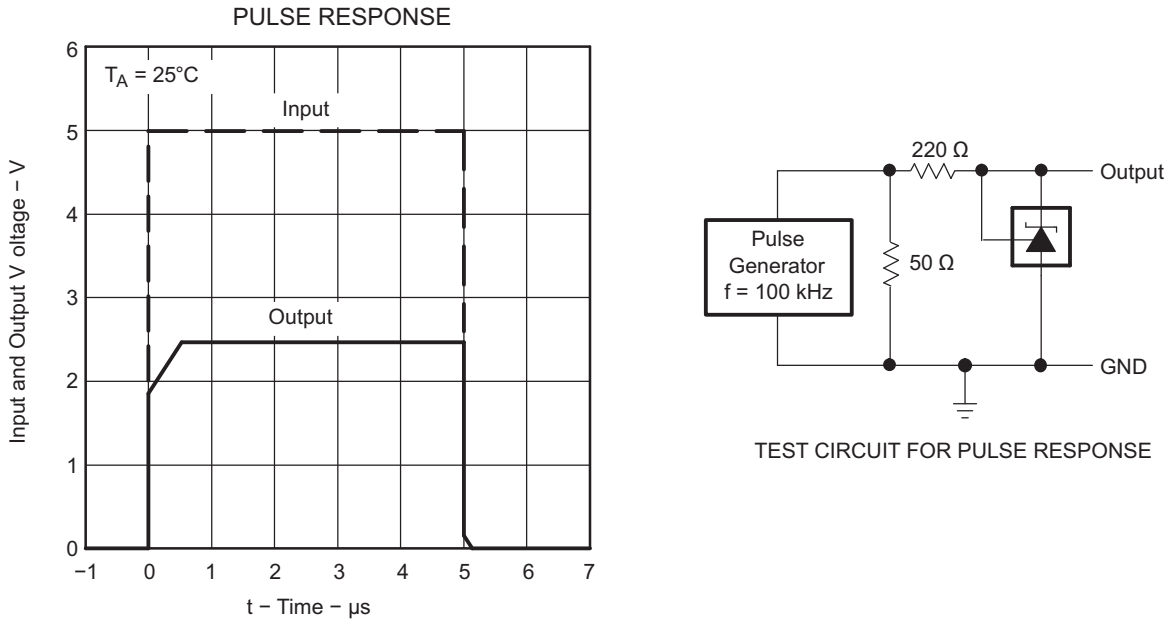
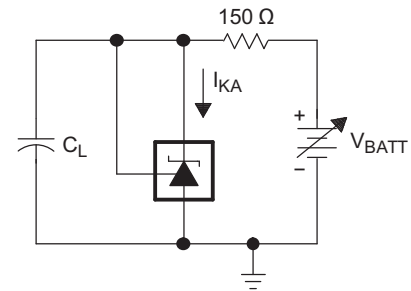
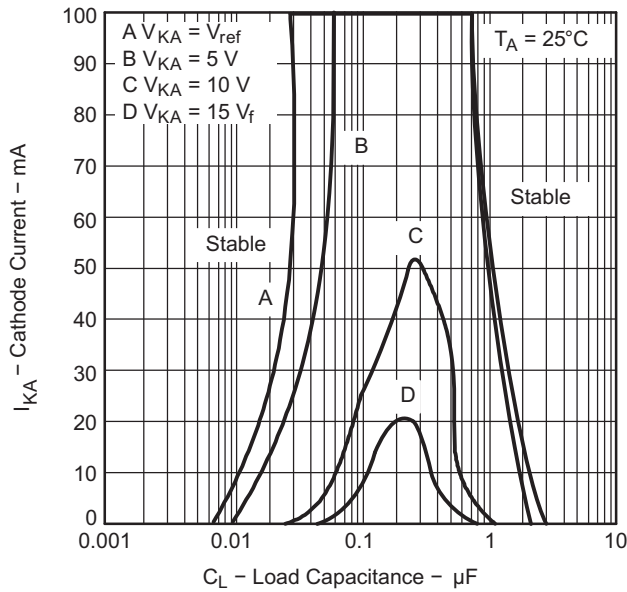
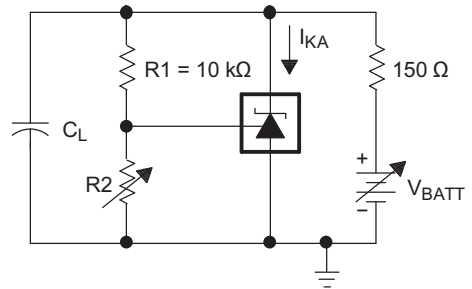

Figure 14.

STABILITY BOUNDARY CONDITIONS FOR ALL TL431 AND TL431A DEVICES (EXCEPT FOR SOT23-3, SC-70, AND Q-TEMP DEVICES)



TEST CIRCUIT FOR CURVE A



TEST CIRCUIT FOR CURVES B, C, AND D

- A. The areas under the curves represent conditions that may cause the device to oscillate. For curves B, C, and D, R2 and V+ are adjusted to establish the initial V_{KA} and I_{KA} conditions, with C_L = 0. V_{BATT} and C_L then are adjusted to determine the ranges of stability.

Figure 15.

Typical Characteristics (continued)

STABILITY BOUNDARY CONDITIONS
FOR ALL TL431B, TL432, SOT-23, SC-70, AND Q-TEMP DEVICES

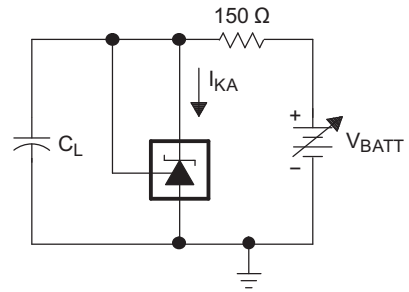
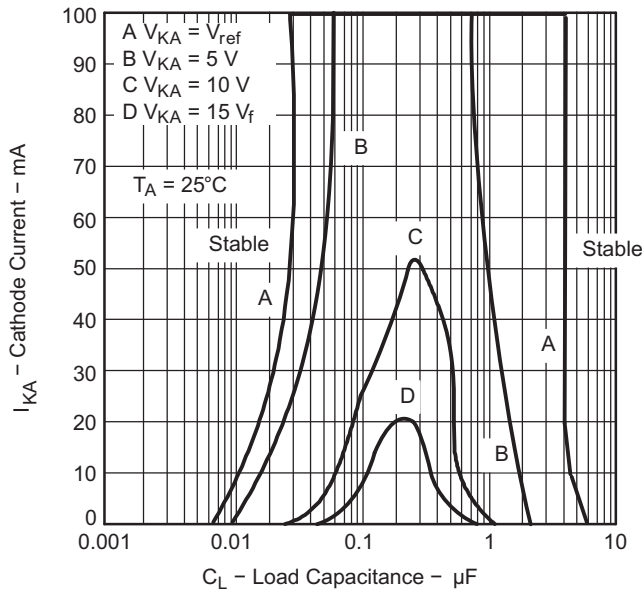

TEST CIRCUIT FOR CURVE A

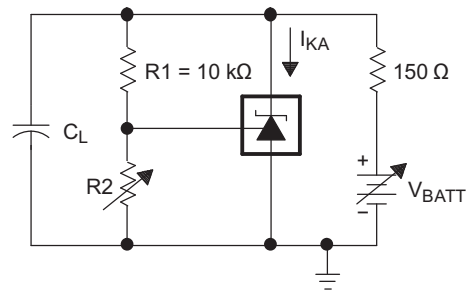

TEST CIRCUIT FOR CURVES B, C, AND D

- A. The areas under the curves represent conditions that may cause the device to oscillate. For curves B, C, and D, $R2$ and $V+$ are adjusted to establish the initial V_{KA} and I_{KA} conditions, with $C_L = 0$. V_{BATT} and C_L then are adjusted to determine the ranges of stability.

Figure 16.

APPLICATION INFORMATION

As this device has many applications and setups, there are many situations that this datasheet can not characterize in detail. The linked application notes will help the designer make the best choices when using this part.

Application note [SLVA482](#) will provide a deeper understanding of this devices stability characteristics and aid the user in making the right choices when choosing a load capacitor. Application note [SLVA445](#) assists designers in setting the shunt voltage to achieve optimum accuracy for this device.

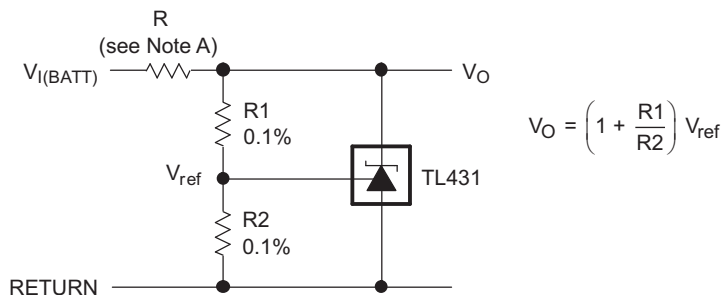

- A. R should provide cathode current ≥ 1 mA to the TL431 at minimum $V_{(BATT)}$.

Figure 17. Shunt Regulator

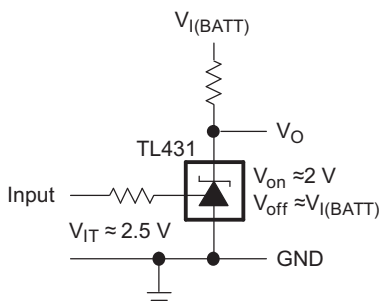
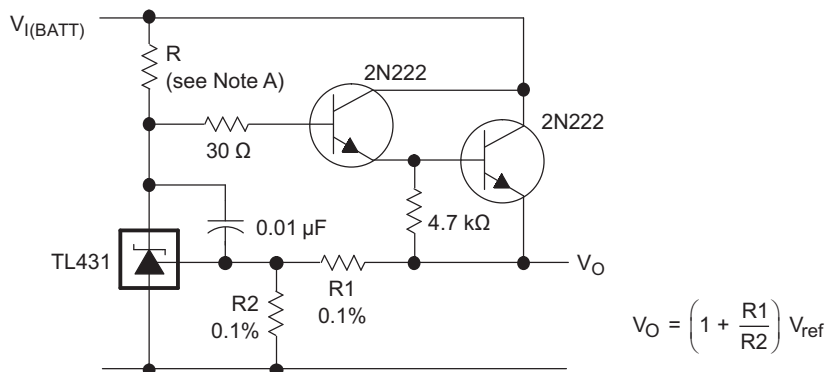

Figure 18. Single-Supply Comparator With Temperature-Compensated Threshold



- A. R should provide cathode current ≥ 1 mA to the TL431 at minimum $V_{(BATT)}$.

Figure 19. Precision High-Current Series Regulator

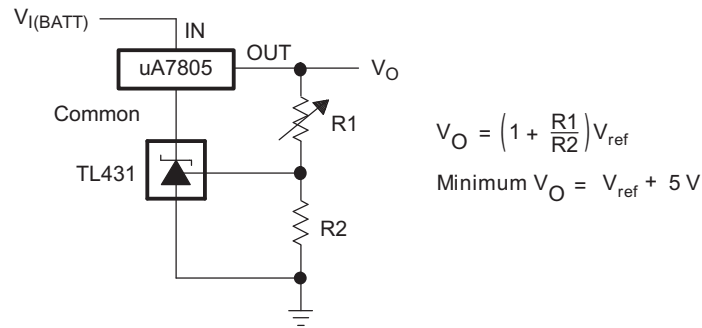

Figure 20. Output Control of a Three-Terminal Fixed Regulator

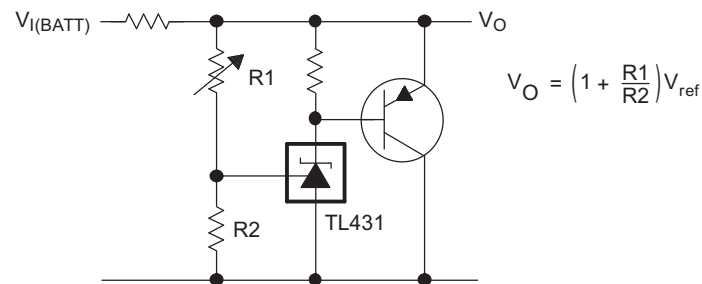
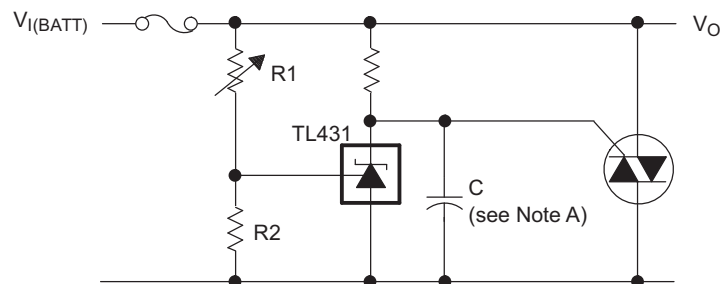

Figure 21. High-Current Shunt Regulator



A. Refer to the stability boundary conditions in [Figure 15](#) and [Figure 16](#) to determine allowable values for C.

Figure 22. Crowbar Circuit

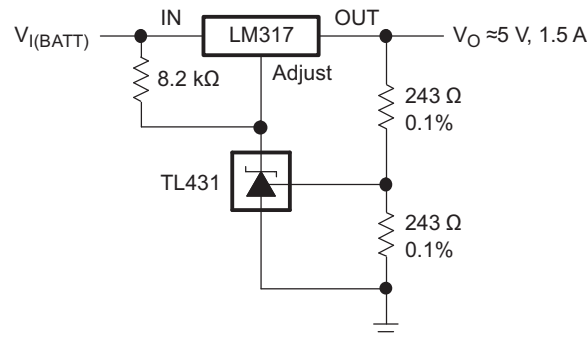
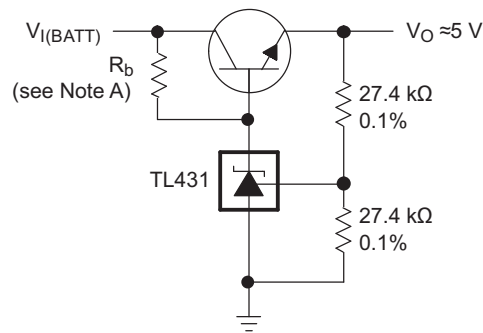

Figure 23. Precision 5-V, 1.5-A Regulator



A. R_b should provide cathode current ≥ 1 mA to the TL431.

Figure 24. Efficient 5-V Precision Regulator

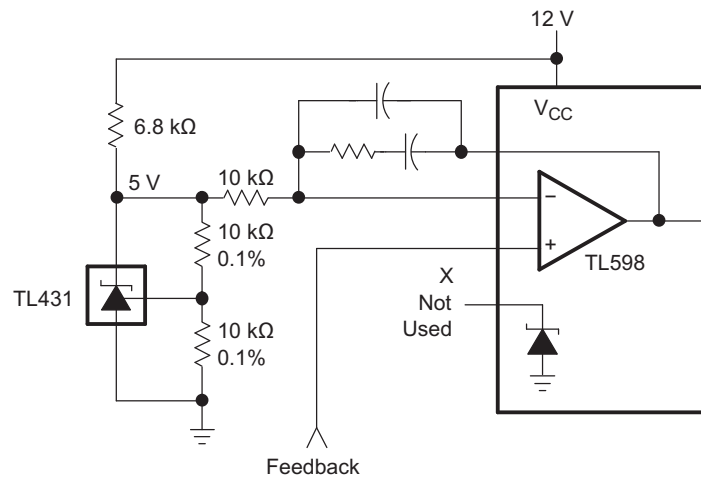
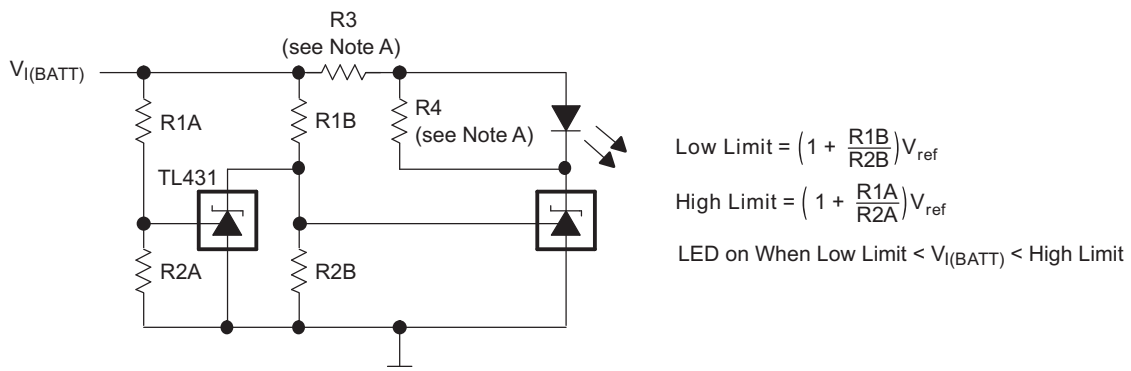

Figure 25. PWM Converter With Reference



A. Select R3 and R4 to provide the desired LED intensity and cathode current ≥ 1 mA to the TL431 at the available $V_{I(BATT)}$.

Figure 26. Voltage Monitor

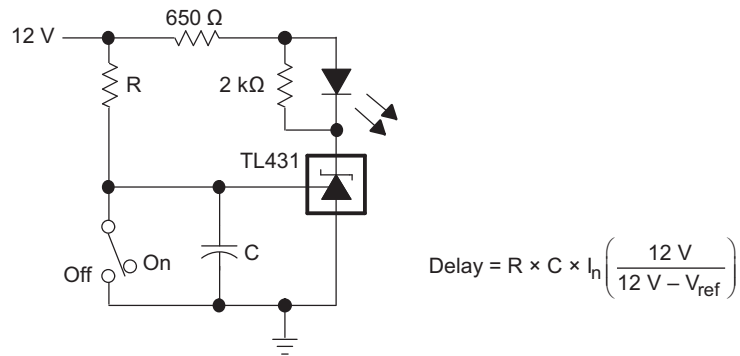

Figure 27. Delay Timer

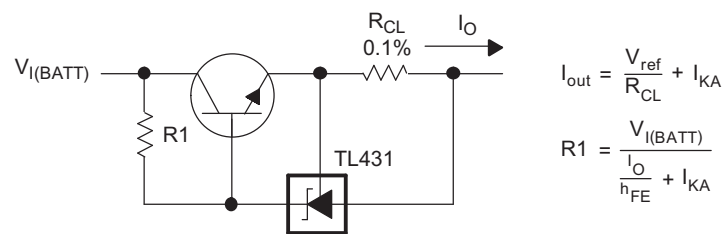

Figure 28. Precision Current Limiter

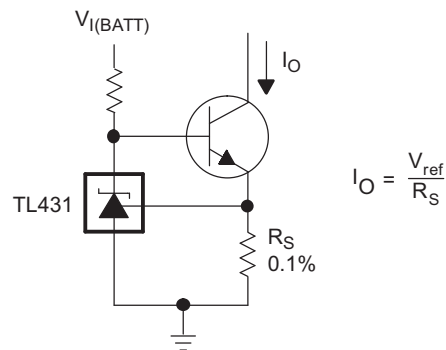

Figure 29. Precision Constant-Current Sink

REVISION HISTORY

Changes from Revision K (June 2010) to Revision L	Page
--	-------------

- Deleted T_A values under TEST CONDITIONS for $V_{I(dev)}$ and $I_{I(dev)}$ PARAMETERS in the ELECTRICAL CHARACTERISTICS table. [5](#)
-

Changes from Revision L (Feb 2011) to Revision M	Page
---	-------------

- Updated orderable part number in ordering information table. [3](#)
-

Changes from Revision M (July 2012) to Revision N	Page
--	-------------

- Updated document formatting [1](#)
 - Removed ordering information table. [3](#)
 - Added Application Note Links [21](#)
-

PACKAGING INFORMATION

Orderable Device	Status (1)	Package Type	Package Drawing	Pins	Package Qty	Eco Plan (2)	Lead/Ball Finish (6)	MSL Peak Temp (3)	Op Temp (°C)	Device Marking (4/5)	Samples
TL431ACD	ACTIVE	SOIC	D	8	75	Green (RoHS & no Sb/Br)	CU NIPDAU	Level-1-260C-UNLIM	0 to 70	431AC	Samples
TL431ACDBVR	ACTIVE	SOT-23	DBV	5	3000	Green (RoHS & no Sb/Br)	CU NIPDAU	Level-1-260C-UNLIM	0 to 70	(TAC3 ~ TACG ~ TACS)	Samples
TL431ACDBVRG4	ACTIVE	SOT-23	DBV	5	3000	Green (RoHS & no Sb/Br)	CU NIPDAU	Level-1-260C-UNLIM	0 to 70	TACG	Samples
TL431ACDBVT	ACTIVE	SOT-23	DBV	5	250	Green (RoHS & no Sb/Br)	CU NIPDAU	Level-1-260C-UNLIM	0 to 70	(TAC3 ~ TACG ~ TACU)	Samples
TL431ACDBVTE4	ACTIVE	SOT-23	DBV	5		TBD	Call TI	Call TI	0 to 70		Samples
TL431ACDBVTG4	ACTIVE	SOT-23	DBV	5		TBD	Call TI	Call TI	0 to 70		Samples
TL431ACDBZR	ACTIVE	SOT-23	DBZ	3	3000	Green (RoHS & no Sb/Br)	CU NIPDAU	Level-1-260C-UNLIM	0 to 70	(TAC3 ~ TACS ~ TACU)	Samples
TL431ACDBZRG4	ACTIVE	SOT-23	DBZ	3	3000	Green (RoHS & no Sb/Br)	CU NIPDAU	Level-1-260C-UNLIM	0 to 70	(TAC3 ~ TACS ~ TACU)	Samples
TL431ACDBZT	ACTIVE	SOT-23	DBZ	3	250	Green (RoHS & no Sb/Br)	CU NIPDAU	Level-1-260C-UNLIM	0 to 70	(TAC3 ~ TACS ~ TACU)	Samples
TL431ACDBZTG4	ACTIVE	SOT-23	DBZ	3	250	Green (RoHS & no Sb/Br)	CU NIPDAU	Level-1-260C-UNLIM	0 to 70	(TAC3 ~ TACS ~ TACU)	Samples
TL431ACDCKR	ACTIVE	SC70	DCK	6	3000	Green (RoHS & no Sb/Br)	CU NIPDAU	Level-1-260C-UNLIM	0 to 70	(T4S ~ T4U)	Samples
TL431ACDG4	ACTIVE	SOIC	D	8	75	Green (RoHS & no Sb/Br)	CU NIPDAU	Level-1-260C-UNLIM	0 to 70	431AC	Samples
TL431ACDR	ACTIVE	SOIC	D	8	2500	Green (RoHS & no Sb/Br)	CU NIPDAU CU SN	Level-1-260C-UNLIM	0 to 70	431AC	Samples
TL431ACDRG4	ACTIVE	SOIC	D	8	2500	Green (RoHS & no Sb/Br)	CU NIPDAU	Level-1-260C-UNLIM	0 to 70	431AC	Samples
TL431ACLPL	ACTIVE	TO-92	LP	3	1000	Pb-Free (RoHS)	CU SN	N / A for Pkg Type	0 to 70	TL431AC	Samples
TL431ACLPE3	ACTIVE	TO-92	LP	3	1000	Pb-Free (RoHS)	CU SN	N / A for Pkg Type	0 to 70	TL431AC	Samples
TL431ACLPM	ACTIVE	TO-92	LP	3	2000	Pb-Free (RoHS)	CU SN	N / A for Pkg Type	0 to 70	TL431AC	Samples

Orderable Device	Status (1)	Package Type	Package Drawing	Pins	Package Qty	Eco Plan (2)	Lead/Ball Finish (6)	MSL Peak Temp (3)	Op Temp (°C)	Device Marking (4/5)	Samples
TL431ACLPR	ACTIVE	TO-92	LP	3	2000	Pb-Free (RoHS)	CU SN	N / A for Pkg Type	0 to 70	TL431AC	Samples
TL431ACP	ACTIVE	PDIP	P	8	50	Pb-Free (RoHS)	CU NIPDAU	N / A for Pkg Type	0 to 70	TL431ACP	Samples
TL431ACPK	ACTIVE	SOT-89	PK	3	1000	Green (RoHS & no Sb/Br)	CU SN	Level-2-260C-1 YEAR	0 to 70	4A	Samples
TL431ACPKG3	ACTIVE	SOT-89	PK	3	1000	Green (RoHS & no Sb/Br)	CU SN	Level-2-260C-1 YEAR	0 to 70	4A	Samples
TL431ACPSR	ACTIVE	SO	PS	8	2000	Green (RoHS & no Sb/Br)	CU NIPDAU	Level-1-260C-UNLIM	0 to 70	T431A	Samples
TL431ACPW	ACTIVE	TSSOP	PW	8	150	Green (RoHS & no Sb/Br)	CU NIPDAU	Level-1-260C-UNLIM	0 to 70	T431A	Samples
TL431ACPWE4	ACTIVE	TSSOP	PW	8	150	Green (RoHS & no Sb/Br)	CU NIPDAU	Level-1-260C-UNLIM	0 to 70	T431A	Samples
TL431ACPWR	ACTIVE	TSSOP	PW	8	2000	Green (RoHS & no Sb/Br)	CU NIPDAU	Level-1-260C-UNLIM	0 to 70	T431A	Samples
TL431ACPWRG4	ACTIVE	TSSOP	PW	8	2000	Green (RoHS & no Sb/Br)	CU NIPDAU	Level-1-260C-UNLIM	0 to 70	T431A	Samples
TL431AID	ACTIVE	SOIC	D	8	75	Green (RoHS & no Sb/Br)	CU NIPDAU	Level-1-260C-UNLIM	-40 to 85	431AI	Samples
TL431AIDBVR	ACTIVE	SOT-23	DBV	5	3000	Green (RoHS & no Sb/Br)	CU NIPDAU	Level-1-260C-UNLIM	-40 to 85	(TAI3 ~ TAIG ~ TAI5)	Samples
TL431AIDBVRE4	ACTIVE	SOT-23	DBV	5	3000	Green (RoHS & no Sb/Br)	CU NIPDAU	Level-1-260C-UNLIM	-40 to 85	TAIG	Samples
TL431AIDBVRG4	ACTIVE	SOT-23	DBV	5	3000	Green (RoHS & no Sb/Br)	CU NIPDAU	Level-1-260C-UNLIM	-40 to 85	TAIG	Samples
TL431AIDBVT	ACTIVE	SOT-23	DBV	5	250	Green (RoHS & no Sb/Br)	CU NIPDAU	Level-1-260C-UNLIM	-40 to 85	(TAI3 ~ TAIG ~ TAIU)	Samples
TL431AIDBVTE4	ACTIVE	SOT-23	DBV	5	250	Green (RoHS & no Sb/Br)	CU NIPDAU	Level-1-260C-UNLIM	-40 to 85	TAIG	Samples
TL431AIDBVTG4	ACTIVE	SOT-23	DBV	5	250	Green (RoHS & no Sb/Br)	CU NIPDAU	Level-1-260C-UNLIM	-40 to 85	TAIG	Samples
TL431AIDBZR	ACTIVE	SOT-23	DBZ	3	3000	Green (RoHS & no Sb/Br)	CU NIPDAU	Level-1-260C-UNLIM	-40 to 85	(TAI3 ~ TAIS ~ TAIU)	Samples
TL431AIDBZRG4	ACTIVE	SOT-23	DBZ	3	3000	Green (RoHS & no Sb/Br)	CU NIPDAU	Level-1-260C-UNLIM	-40 to 85	(TAI3 ~ TAIS ~ TAIU)	Samples

Orderable Device	Status (1)	Package Type	Package Drawing	Pins	Package Qty	Eco Plan (2)	Lead/Ball Finish (6)	MSL Peak Temp (3)	Op Temp (°C)	Device Marking (4/5)	Samples
TL431AIDBZT	ACTIVE	SOT-23	DBZ	3	250	Green (RoHS & no Sb/Br)	CU NIPDAU	Level-1-260C-UNLIM	-40 to 85	(TAI3 ~ TAIS ~ TAIU)	Samples
TL431AIDBZTG4	ACTIVE	SOT-23	DBZ	3	250	Green (RoHS & no Sb/Br)	CU NIPDAU	Level-1-260C-UNLIM	-40 to 85	(TAI3 ~ TAIS ~ TAIU)	Samples
TL431AIDCKR	ACTIVE	SC70	DCK	6	3000	Green (RoHS & no Sb/Br)	CU NIPDAU	Level-1-260C-UNLIM	-40 to 85	T5U	Samples
TL431AIDCKRE4	ACTIVE	SC70	DCK	6	3000	Green (RoHS & no Sb/Br)	CU NIPDAU	Level-1-260C-UNLIM	-40 to 85	T5U	Samples
TL431AIDCKRG4	ACTIVE	SC70	DCK	6	3000	Green (RoHS & no Sb/Br)	CU NIPDAU	Level-1-260C-UNLIM	-40 to 85	T5U	Samples
TL431AIDCKT	ACTIVE	SC70	DCK	6	250	Green (RoHS & no Sb/Br)	CU NIPDAU	Level-1-260C-UNLIM	-40 to 85	T5U	Samples
TL431AIDCKTG4	ACTIVE	SC70	DCK	6	250	Green (RoHS & no Sb/Br)	CU NIPDAU	Level-1-260C-UNLIM	-40 to 85	T5U	Samples
TL431AIDG4	ACTIVE	SOIC	D	8	75	Green (RoHS & no Sb/Br)	CU NIPDAU	Level-1-260C-UNLIM	-40 to 85	431AI	Samples
TL431AIDR	ACTIVE	SOIC	D	8	2500	Green (RoHS & no Sb/Br)	CU NIPDAU CU SN	Level-1-260C-UNLIM	-40 to 85	431AI	Samples
TL431AIDRG4	ACTIVE	SOIC	D	8	2500	Green (RoHS & no Sb/Br)	CU NIPDAU	Level-1-260C-UNLIM	-40 to 85	431AI	Samples
TL431AILP	ACTIVE	TO-92	LP	3	1000	Pb-Free (RoHS)	CU SN	N / A for Pkg Type	-40 to 85	TL431AI	Samples
TL431AILPM	ACTIVE	TO-92	LP	3	2000	Pb-Free (RoHS)	CU SN	N / A for Pkg Type	-40 to 85	TL431AI	Samples
TL431AILPME3	ACTIVE	TO-92	LP	3	2000	Pb-Free (RoHS)	CU SN	N / A for Pkg Type	-40 to 85	TL431AI	Samples
TL431AILPR	ACTIVE	TO-92	LP	3	2000	Pb-Free (RoHS)	CU SN	N / A for Pkg Type	-40 to 85	TL431AI	Samples
TL431AIP	ACTIVE	PDIP	P	8	50	Pb-Free (RoHS)	CU NIPDAU	N / A for Pkg Type	-40 to 85	TL431AIP	Samples
TL431AIPE4	ACTIVE	PDIP	P	8	50	Pb-Free (RoHS)	CU NIPDAU	N / A for Pkg Type	-40 to 85	TL431AIP	Samples
TL431AIPK	ACTIVE	SOT-89	PK	3	1000	Green (RoHS & no Sb/Br)	CU SN	Level-2-260C-1 YEAR	-40 to 85	4B	Samples
TL431AIPKG3	ACTIVE	SOT-89	PK	3	1000	Green (RoHS & no Sb/Br)	CU SN	Level-2-260C-1 YEAR	-40 to 85	4B	Samples

Orderable Device	Status (1)	Package Type	Package Drawing	Pins	Package Qty	Eco Plan (2)	Lead/Ball Finish (6)	MSL Peak Temp (3)	Op Temp (°C)	Device Marking (4/5)	Samples
TL431AQDBVR	ACTIVE	SOT-23	DBV	5	3000	Green (RoHS & no Sb/Br)	CU NIPDAU	Level-1-260C-UNLIM	-40 to 125	(TAQG ~ TAQU)	Samples
TL431AQDBVT	ACTIVE	SOT-23	DBV	5	250	Green (RoHS & no Sb/Br)	CU NIPDAU	Level-1-260C-UNLIM	-40 to 125	(TAQG ~ TAQU)	Samples
TL431AQDBZR	ACTIVE	SOT-23	DBZ	3	3000	Green (RoHS & no Sb/Br)	CU NIPDAU	Level-1-260C-UNLIM	-40 to 125	(TAQ3 ~ TAQS ~ TAQU)	Samples
TL431AQDBZRG4	ACTIVE	SOT-23	DBZ	3	3000	Green (RoHS & no Sb/Br)	CU NIPDAU	Level-1-260C-UNLIM	-40 to 125	(TAQ3 ~ TAQS ~ TAQU)	Samples
TL431AQDBZT	ACTIVE	SOT-23	DBZ	3	250	Green (RoHS & no Sb/Br)	CU NIPDAU	Level-1-260C-UNLIM	-40 to 125	(TAQS ~ TAQU)	Samples
TL431AQDBZTG4	ACTIVE	SOT-23	DBZ	3	250	Green (RoHS & no Sb/Br)	CU NIPDAU	Level-1-260C-UNLIM	-40 to 125	(TAQS ~ TAQU)	Samples
TL431AQDCKR	ACTIVE	SC70	DCK	6	3000	Green (RoHS & no Sb/Br)	CU NIPDAU	Level-1-260C-UNLIM	-40 to 125	T7U	Samples
TL431AQDCKT	ACTIVE	SC70	DCK	6	250	Green (RoHS & no Sb/Br)	CU NIPDAU	Level-1-260C-UNLIM	-40 to 125	T7U	Samples
TL431AQPCK	ACTIVE	SOT-89	PK	3	1000	Green (RoHS & no Sb/Br)	CU SN	Level-2-260C-1 YEAR	-40 to 125	4D	Samples
TL431AQPCKG3	ACTIVE	SOT-89	PK	3	1000	Green (RoHS & no Sb/Br)	CU SN	Level-2-260C-1 YEAR	-40 to 125	4D	Samples
TL431BCD	ACTIVE	SOIC	D	8	75	Green (RoHS & no Sb/Br)	CU NIPDAU	Level-1-260C-UNLIM	0 to 70	T431B	Samples
TL431BCDBVR	ACTIVE	SOT-23	DBV	5	3000	Green (RoHS & no Sb/Br)	CU NIPDAU CU SN	Level-1-260C-UNLIM	0 to 70	(T3G3 ~ T3GG ~ T3GU)	Samples
TL431BCDBVT	ACTIVE	SOT-23	DBV	5	250	Green (RoHS & no Sb/Br)	CU NIPDAU CU SN	Level-1-260C-UNLIM	0 to 70	(T3G3 ~ T3GG ~ T3GU)	Samples
TL431BCDBVTE4	ACTIVE	SOT-23	DBV	5	250	Green (RoHS & no Sb/Br)	CU NIPDAU	Level-1-260C-UNLIM	0 to 70	T3GG	Samples
TL431BCDBVTG4	ACTIVE	SOT-23	DBV	5	250	Green (RoHS & no Sb/Br)	CU NIPDAU	Level-1-260C-UNLIM	0 to 70	T3GG	Samples
TL431BCDBZR	ACTIVE	SOT-23	DBZ	3	3000	Green (RoHS & no Sb/Br)	CU NIPDAU	Level-1-260C-UNLIM	0 to 70	(T3G3 ~ T3GS ~ T3GU)	Samples
TL431BCDBZRG4	ACTIVE	SOT-23	DBZ	3	3000	Green (RoHS & no Sb/Br)	CU NIPDAU	Level-1-260C-UNLIM	0 to 70	(T3G3 ~ T3GS ~ T3GU)	Samples
TL431BCDBZT	ACTIVE	SOT-23	DBZ	3	250	Green (RoHS & no Sb/Br)	CU NIPDAU	Level-1-260C-UNLIM	0 to 70	(T3G3 ~ T3GS ~ T3GU)	Samples

Orderable Device	Status (1)	Package Type	Package Drawing	Pins	Package Qty	Eco Plan (2)	Lead/Ball Finish (6)	MSL Peak Temp (3)	Op Temp (°C)	Device Marking (4/5)	Samples
TL431BCDBZTG4	ACTIVE	SOT-23	DBZ	3	250	Green (RoHS & no Sb/Br)	CU NIPDAU	Level-1-260C-UNLIM	0 to 70	(T3G3 ~ T3GS ~ T3GU)	Samples
TL431BCDCKR	ACTIVE	SC70	DCK	6	3000	Green (RoHS & no Sb/Br)	CU NIPDAU	Level-1-260C-UNLIM	0 to 70	T2U	Samples
TL431BCDCKT	ACTIVE	SC70	DCK	6	250	Green (RoHS & no Sb/Br)	CU NIPDAU	Level-1-260C-UNLIM	0 to 70	T2U	Samples
TL431BCDE4	ACTIVE	SOIC	D	8	75	Green (RoHS & no Sb/Br)	CU NIPDAU	Level-1-260C-UNLIM	0 to 70	T431B	Samples
TL431BCDG4	ACTIVE	SOIC	D	8	75	Green (RoHS & no Sb/Br)	CU NIPDAU	Level-1-260C-UNLIM	0 to 70	T431B	Samples
TL431BCDR	ACTIVE	SOIC	D	8	2500	Green (RoHS & no Sb/Br)	CU NIPDAU	Level-1-260C-UNLIM	0 to 70	T431B	Samples
TL431BCDRG4	ACTIVE	SOIC	D	8	2500	Green (RoHS & no Sb/Br)	CU NIPDAU	Level-1-260C-UNLIM	0 to 70	T431B	Samples
TL431BCLP	ACTIVE	TO-92	LP	3	1000	Pb-Free (RoHS)	CU SN	N / A for Pkg Type	0 to 70	T431B	Samples
TL431BCLPE3	ACTIVE	TO-92	LP	3	1000	Pb-Free (RoHS)	CU SN	N / A for Pkg Type	0 to 70	T431B	Samples
TL431BCLPR	ACTIVE	TO-92	LP	3	2000	Pb-Free (RoHS)	CU SN	N / A for Pkg Type	0 to 70	T431B	Samples
TL431BCP	ACTIVE	PDIP	P	8	50	Pb-Free (RoHS)	CU NIPDAU	N / A for Pkg Type	0 to 70	TL431BCP	Samples
TL431BCPK	ACTIVE	SOT-89	PK	3	1000	Green (RoHS & no Sb/Br)	CU SN	Level-2-260C-1 YEAR	0 to 70	4C	Samples
TL431BCPKG3	ACTIVE	SOT-89	PK	3	1000	Green (RoHS & no Sb/Br)	CU SN	Level-2-260C-1 YEAR	0 to 70	4C	Samples
TL431BCPSR	ACTIVE	SO	PS	8	2000	Green (RoHS & no Sb/Br)	CU NIPDAU	Level-1-260C-UNLIM	0 to 70	T431B	Samples
TL431BCPSRE4	ACTIVE	SO	PS	8	2000	Green (RoHS & no Sb/Br)	CU NIPDAU	Level-1-260C-UNLIM	0 to 70	T431B	Samples
TL431BCPWR	ACTIVE	TSSOP	PW	8	2000	Green (RoHS & no Sb/Br)	CU NIPDAU	Level-1-260C-UNLIM	0 to 70	T431B	Samples
TL431BID	ACTIVE	SOIC	D	8	75	Green (RoHS & no Sb/Br)	CU NIPDAU	Level-1-260C-UNLIM	-40 to 85	Z431B	Samples
TL431BIDBVR	ACTIVE	SOT-23	DBV	5	3000	Green (RoHS & no Sb/Br)	CU NIPDAU CU SN	Level-1-260C-UNLIM	-40 to 85	(T3F3 ~ T3FG ~ T3FU)	Samples

Orderable Device	Status (1)	Package Type	Package Drawing	Pins	Package Qty	Eco Plan (2)	Lead/Ball Finish (6)	MSL Peak Temp (3)	Op Temp (°C)	Device Marking (4/5)	Samples
TL431BIDBVT	ACTIVE	SOT-23	DBV	5	250	Green (RoHS & no Sb/Br)	CU NIPDAU CU SN	Level-1-260C-UNLIM	-40 to 85	(T3F3 ~ T3FG ~ T3FU)	Samples
TL431BIDBVTE4	ACTIVE	SOT-23	DBV	5	250	Green (RoHS & no Sb/Br)	CU NIPDAU	Level-1-260C-UNLIM	-40 to 85	T3FG	Samples
TL431BIDBVTG4	ACTIVE	SOT-23	DBV	5	250	Green (RoHS & no Sb/Br)	CU NIPDAU	Level-1-260C-UNLIM	-40 to 85	T3FG	Samples
TL431BIDBZR	ACTIVE	SOT-23	DBZ	3	3000	Green (RoHS & no Sb/Br)	CU NIPDAU	Level-1-260C-UNLIM	-40 to 85	(T3F3 ~ T3FS ~ T3FU)	Samples
TL431BIDBZRG4	ACTIVE	SOT-23	DBZ	3	3000	Green (RoHS & no Sb/Br)	CU NIPDAU	Level-1-260C-UNLIM	-40 to 85	(T3F3 ~ T3FS ~ T3FU)	Samples
TL431BIDBZT	ACTIVE	SOT-23	DBZ	3	250	Green (RoHS & no Sb/Br)	CU NIPDAU	Level-1-260C-UNLIM	-40 to 85	(T3F3 ~ T3FS ~ T3FU)	Samples
TL431BIDBZTG4	ACTIVE	SOT-23	DBZ	3	250	Green (RoHS & no Sb/Br)	CU NIPDAU	Level-1-260C-UNLIM	-40 to 85	(T3F3 ~ T3FS ~ T3FU)	Samples
TL431BIDCKR	ACTIVE	SC70	DCK	6	3000	Green (RoHS & no Sb/Br)	CU NIPDAU	Level-1-260C-UNLIM	-40 to 85	T3U	Samples
TL431BIDCKT	ACTIVE	SC70	DCK	6	250	Green (RoHS & no Sb/Br)	CU NIPDAU	Level-1-260C-UNLIM	-40 to 85	T3U	Samples
TL431BIDCKTE4	ACTIVE	SC70	DCK	6	250	Green (RoHS & no Sb/Br)	CU NIPDAU	Level-1-260C-UNLIM	-40 to 85	T3U	Samples
TL431BIDCKTG4	ACTIVE	SC70	DCK	6	250	Green (RoHS & no Sb/Br)	CU NIPDAU	Level-1-260C-UNLIM	-40 to 85	T3U	Samples
TL431BIDE4	ACTIVE	SOIC	D	8	75	Green (RoHS & no Sb/Br)	CU NIPDAU	Level-1-260C-UNLIM	-40 to 85	Z431B	Samples
TL431BIDG4	ACTIVE	SOIC	D	8	75	Green (RoHS & no Sb/Br)	CU NIPDAU	Level-1-260C-UNLIM	-40 to 85	Z431B	Samples
TL431BIDR	ACTIVE	SOIC	D	8	2500	Green (RoHS & no Sb/Br)	CU NIPDAU CU SN	Level-1-260C-UNLIM	-40 to 85	Z431B	Samples
TL431BIDRE4	ACTIVE	SOIC	D	8	2500	Green (RoHS & no Sb/Br)	CU NIPDAU	Level-1-260C-UNLIM	-40 to 85	Z431B	Samples
TL431BIDRG4	ACTIVE	SOIC	D	8	2500	Green (RoHS & no Sb/Br)	CU NIPDAU	Level-1-260C-UNLIM	-40 to 85	Z431B	Samples
TL431BILP	ACTIVE	TO-92	LP	3	1000	Pb-Free (RoHS)	CU SN	N / A for Pkg Type	-40 to 85	Z431B	Samples
TL431BILPE3	ACTIVE	TO-92	LP	3	1000	Pb-Free (RoHS)	CU SN	N / A for Pkg Type	-40 to 85	Z431B	Samples

Orderable Device	Status (1)	Package Type	Package Drawing	Pins	Package Qty	Eco Plan (2)	Lead/Ball Finish (6)	MSL Peak Temp (3)	Op Temp (°C)	Device Marking (4/5)	Samples
TL431BILPR	ACTIVE	TO-92	LP	3	2000	Pb-Free (RoHS)	CU SN	N / A for Pkg Type	-40 to 85	Z431B	Samples
TL431BILPRE3	ACTIVE	TO-92	LP	3	2000	Pb-Free (RoHS)	CU SN	N / A for Pkg Type	-40 to 85	Z431B	Samples
TL431BIP	ACTIVE	PDIP	P	8	50	Pb-Free (RoHS)	CU NIPDAU	N / A for Pkg Type	-40 to 85	TL431BIP	Samples
TL431BIPE4	ACTIVE	PDIP	P	8	50	Pb-Free (RoHS)	CU NIPDAU	N / A for Pkg Type	-40 to 85	TL431BIP	Samples
TL431BIPK	ACTIVE	SOT-89	PK	3	1000	Green (RoHS & no Sb/Br)	CU SN	Level-2-260C-1 YEAR	-40 to 85	4I	Samples
TL431BIPKG3	ACTIVE	SOT-89	PK	3	1000	Green (RoHS & no Sb/Br)	CU SN	Level-2-260C-1 YEAR	-40 to 85	4I	Samples
TL431BQD	ACTIVE	SOIC	D	8	75	Green (RoHS & no Sb/Br)	CU NIPDAU	Level-1-260C-UNLIM	-40 to 125	T431BQ	Samples
TL431BQDBVR	ACTIVE	SOT-23	DBV	5	3000	Green (RoHS & no Sb/Br)	CU NIPDAU	Level-1-260C-UNLIM	-40 to 125	(T3H3 ~ T3HU)	Samples
TL431BQDBVRG4	ACTIVE	SOT-23	DBV	5	3000	Green (RoHS & no Sb/Br)	CU NIPDAU	Level-1-260C-UNLIM	-40 to 125	(T3H3 ~ T3HU)	Samples
TL431BQDBVT	ACTIVE	SOT-23	DBV	5	250	Green (RoHS & no Sb/Br)	CU NIPDAU	Level-1-260C-UNLIM	-40 to 125	(T3H3 ~ T3HU)	Samples
TL431BQDBVTE4	ACTIVE	SOT-23	DBV	5	250	Green (RoHS & no Sb/Br)	CU NIPDAU	Level-1-260C-UNLIM	-40 to 125	(T3H3 ~ T3HU)	Samples
TL431BQDBZR	ACTIVE	SOT-23	DBZ	3	3000	Green (RoHS & no Sb/Br)	CU NIPDAU	Level-1-260C-UNLIM	-40 to 125	(T3H3 ~ T3HS ~ T3HU)	Samples
TL431BQDBZRG4	ACTIVE	SOT-23	DBZ	3	3000	Green (RoHS & no Sb/Br)	CU NIPDAU	Level-1-260C-UNLIM	-40 to 125	(T3H3 ~ T3HS ~ T3HU)	Samples
TL431BQDBZT	ACTIVE	SOT-23	DBZ	3	250	Green (RoHS & no Sb/Br)	CU NIPDAU	Level-1-260C-UNLIM	-40 to 125	(T3HS ~ T3HU)	Samples
TL431BQDBZTG4	ACTIVE	SOT-23	DBZ	3	250	Green (RoHS & no Sb/Br)	CU NIPDAU	Level-1-260C-UNLIM	-40 to 125	(T3HS ~ T3HU)	Samples
TL431BQDCKR	ACTIVE	SC70	DCK	6	3000	Green (RoHS & no Sb/Br)	CU NIPDAU	Level-1-260C-UNLIM	-40 to 125	T8U	Samples
TL431BQDCKT	ACTIVE	SC70	DCK	6	250	Green (RoHS & no Sb/Br)	CU NIPDAU	Level-1-260C-UNLIM	-40 to 125	T8U	Samples
TL431BQDCKTE4	ACTIVE	SC70	DCK	6	250	Green (RoHS & no Sb/Br)	CU NIPDAU	Level-1-260C-UNLIM	-40 to 125	T8U	Samples

Orderable Device	Status (1)	Package Type	Package Drawing	Pins	Package Qty	Eco Plan (2)	Lead/Ball Finish (6)	MSL Peak Temp (3)	Op Temp (°C)	Device Marking (4/5)	Samples
TL431BQDCKTG4	ACTIVE	SC70	DCK	6	250	Green (RoHS & no Sb/Br)	CU NIPDAU	Level-1-260C-UNLIM	-40 to 125	T8U	Samples
TL431BQDE4	ACTIVE	SOIC	D	8	75	Green (RoHS & no Sb/Br)	CU NIPDAU	Level-1-260C-UNLIM	-40 to 125	T431BQ	Samples
TL431BQDR	ACTIVE	SOIC	D	8	2500	Green (RoHS & no Sb/Br)	CU NIPDAU	Level-1-260C-UNLIM	-40 to 125	T431BQ	Samples
TL431BQDRE4	ACTIVE	SOIC	D	8	2500	Green (RoHS & no Sb/Br)	CU NIPDAU	Level-1-260C-UNLIM	-40 to 125	T431BQ	Samples
TL431BQDRG4	ACTIVE	SOIC	D	8	2500	Green (RoHS & no Sb/Br)	CU NIPDAU	Level-1-260C-UNLIM	-40 to 125	T431BQ	Samples
TL431BQLP	ACTIVE	TO-92	LP	3	1000	Pb-Free (RoHS)	CU SN	N / A for Pkg Type	-40 to 125	T431BQ	Samples
TL431BQLPE3	ACTIVE	TO-92	LP	3	1000	Pb-Free (RoHS)	CU SN	N / A for Pkg Type	-40 to 125	T431BQ	Samples
TL431BQLPM	ACTIVE	TO-92	LP	3	2000	Pb-Free (RoHS)	CU SN	N / A for Pkg Type	-40 to 125	T431BQ	Samples
TL431BQLPME3	ACTIVE	TO-92	LP	3	2000	Pb-Free (RoHS)	CU SN	N / A for Pkg Type	-40 to 125	T431BQ	Samples
TL431BQLPR	ACTIVE	TO-92	LP	3	2000	Pb-Free (RoHS)	CU SN	N / A for Pkg Type	-40 to 125	T431BQ	Samples
TL431BQLPRE3	ACTIVE	TO-92	LP	3	2000	Pb-Free (RoHS)	CU SN	N / A for Pkg Type	-40 to 125	T431BQ	Samples
TL431BQPK	ACTIVE	SOT-89	PK	3	1000	Green (RoHS & no Sb/Br)	CU SN	Level-2-260C-1 YEAR	-40 to 125	3H	Samples
TL431BQPKG3	ACTIVE	SOT-89	PK	3	1000	Green (RoHS & no Sb/Br)	CU SN	Level-2-260C-1 YEAR	-40 to 125	3H	Samples
TL431BQPSR	PREVIEW	SO	PS	8	2000	TBD	Call TI	Call TI	-40 to 125	T431BQ	
TL431CD	ACTIVE	SOIC	D	8	75	Green (RoHS & no Sb/Br)	CU NIPDAU	Level-1-260C-UNLIM	0 to 70	TL431C	Samples
TL431CDBVR	ACTIVE	SOT-23	DBV	5	3000	Green (RoHS & no Sb/Br)	CU NIPDAU CU SN	Level-1-260C-UNLIM	0 to 70	(T3C3 ~ T3CG ~ T3CS)	Samples
TL431CDBVRE4	ACTIVE	SOT-23	DBV	5		TBD	Call TI	Call TI	0 to 70		Samples
TL431CDBVRG4	ACTIVE	SOT-23	DBV	5		TBD	Call TI	Call TI	0 to 70		Samples
TL431CDBVT	ACTIVE	SOT-23	DBV	5	250	Green (RoHS & no Sb/Br)	CU NIPDAU CU SN	Level-1-260C-UNLIM	0 to 70	(T3C3 ~ T3CG ~ T3CS)	Samples

Orderable Device	Status (1)	Package Type	Package Drawing	Pins	Package Qty	Eco Plan (2)	Lead/Ball Finish (6)	MSL Peak Temp (3)	Op Temp (°C)	Device Marking (4/5)	Samples
TL431CDBVTG4	ACTIVE	SOT-23	DBV	5	250	Green (RoHS & no Sb/Br)	CU NIPDAU	Level-1-260C-UNLIM	0 to 70	T3CG	Samples
TL431CDBZR	ACTIVE	SOT-23	DBZ	3	3000	Green (RoHS & no Sb/Br)	CU NIPDAU	Level-1-260C-UNLIM	0 to 70	(T3C3 ~ T3CS ~ T3CU)	Samples
TL431CDBZRG4	ACTIVE	SOT-23	DBZ	3	3000	Green (RoHS & no Sb/Br)	CU NIPDAU	Level-1-260C-UNLIM	0 to 70	(T3C3 ~ T3CS ~ T3CU)	Samples
TL431CDBZT	ACTIVE	SOT-23	DBZ	3	250	Green (RoHS & no Sb/Br)	CU NIPDAU	Level-1-260C-UNLIM	0 to 70	(T3CS ~ T3CU)	Samples
TL431CDBZTG4	ACTIVE	SOT-23	DBZ	3	250	Green (RoHS & no Sb/Br)	CU NIPDAU	Level-1-260C-UNLIM	0 to 70	(T3CS ~ T3CU)	Samples
TL431CDG4	ACTIVE	SOIC	D	8	75	Green (RoHS & no Sb/Br)	CU NIPDAU	Level-1-260C-UNLIM	0 to 70	TL431C	Samples
TL431CDR	ACTIVE	SOIC	D	8	2500	Green (RoHS & no Sb/Br)	CU NIPDAU CU SN	Level-1-260C-UNLIM	0 to 70	TL431C	Samples
TL431CDRG4	ACTIVE	SOIC	D	8	2500	Green (RoHS & no Sb/Br)	CU NIPDAU	Level-1-260C-UNLIM	0 to 70	TL431C	Samples
TL431CKTPR	OBSOLETE	PFM	KTP	2		TBD	Call TI	Call TI	0 to 70		
TL431CLP	ACTIVE	TO-92	LP	3	1000	Pb-Free (RoHS)	CU SN	N / A for Pkg Type	0 to 70	TL431C	Samples
TL431CLPB-TDJ	OBSOLETE	TO-92	LP	3		TBD	Call TI	Call TI	0 to 75		
TL431CLPM	ACTIVE	TO-92	LP	3	2000	Pb-Free (RoHS)	CU SN	N / A for Pkg Type	0 to 70	TL431C	Samples
TL431CLPR	ACTIVE	TO-92	LP	3	2000	Pb-Free (RoHS)	CU SN	N / A for Pkg Type	0 to 70	TL431C	Samples
TL431CP	ACTIVE	PDIP	P	8	50	Pb-Free (RoHS)	CU NIPDAU	N / A for Pkg Type	0 to 70	TL431CP	Samples
TL431CPE4	ACTIVE	PDIP	P	8	50	Pb-Free (RoHS)	CU NIPDAU	N / A for Pkg Type	0 to 70	TL431CP	Samples
TL431CPK	ACTIVE	SOT-89	PK	3	1000	Green (RoHS & no Sb/Br)	CU SN	Level-2-260C-1 YEAR	0 to 70	43	Samples
TL431CPKG3	ACTIVE	SOT-89	PK	3	1000	Green (RoHS & no Sb/Br)	CU SN	Level-2-260C-1 YEAR	0 to 70	43	Samples
TL431CPSLE	OBSOLETE	SO	PS	8		TBD	Call TI	Call TI	0 to 70		
TL431CPSR	ACTIVE	SO	PS	8	2000	Green (RoHS & no Sb/Br)	CU NIPDAU	Level-1-260C-UNLIM	0 to 70	T431	Samples

Orderable Device	Status (1)	Package Type	Package Drawing	Pins	Package Qty	Eco Plan (2)	Lead/Ball Finish (6)	MSL Peak Temp (3)	Op Temp (°C)	Device Marking (4/5)	Samples
TL431CPSRG4	ACTIVE	SO	PS	8	2000	Green (RoHS & no Sb/Br)	CU NIPDAU	Level-1-260C-UNLIM	0 to 70	T431	Samples
TL431CPW	OBSOLETE	TSSOP	PW	8		TBD	Call TI	Call TI	0 to 70		
TL431CPWE4	OBSOLETE	TSSOP	PW	8		TBD	Call TI	Call TI	0 to 70		
TL431CPWG4	OBSOLETE	TSSOP	PW	8		TBD	Call TI	Call TI	0 to 70		
TL431CPWLE	OBSOLETE	TSSOP	PW	8		TBD	Call TI	Call TI	0 to 70		
TL431CPWR	ACTIVE	TSSOP	PW	8	2000	Green (RoHS & no Sb/Br)	CU NIPDAU	Level-1-260C-UNLIM	0 to 70	T431	Samples
TL431ID	ACTIVE	SOIC	D	8	75	Green (RoHS & no Sb/Br)	CU NIPDAU	Level-1-260C-UNLIM	-40 to 85	TL431I	Samples
TL431IDBVR	ACTIVE	SOT-23	DBV	5	3000	Green (RoHS & no Sb/Br)	CU NIPDAU	Level-1-260C-UNLIM	-40 to 85	(T3I3 ~ T3IG ~ T3IS)	Samples
TL431IDBVRE4	ACTIVE	SOT-23	DBV	5	3000	Green (RoHS & no Sb/Br)	CU NIPDAU	Level-1-260C-UNLIM	-40 to 85	T3IG	Samples
TL431IDBVRG4	ACTIVE	SOT-23	DBV	5	3000	Green (RoHS & no Sb/Br)	CU NIPDAU	Level-1-260C-UNLIM	-40 to 85	T3IG	Samples
TL431IDBVT	ACTIVE	SOT-23	DBV	5	250	Green (RoHS & no Sb/Br)	CU NIPDAU	Level-1-260C-UNLIM	-40 to 85	(T3I3 ~ T3IG ~ T3IU)	Samples
TL431IDBZR	ACTIVE	SOT-23	DBZ	3	3000	Green (RoHS & no Sb/Br)	CU NIPDAU	Level-1-260C-UNLIM	-40 to 85	(T3I3 ~ T3IS ~ T3IU)	Samples
TL431IDBZRG4	ACTIVE	SOT-23	DBZ	3	3000	Green (RoHS & no Sb/Br)	CU NIPDAU	Level-1-260C-UNLIM	-40 to 85	(T3I3 ~ T3IS ~ T3IU)	Samples
TL431IDBZT	ACTIVE	SOT-23	DBZ	3	250	Green (RoHS & no Sb/Br)	CU NIPDAU	Level-1-260C-UNLIM	-40 to 85	(T3IS ~ T3IU)	Samples
TL431IDBZTG4	ACTIVE	SOT-23	DBZ	3	250	Green (RoHS & no Sb/Br)	CU NIPDAU	Level-1-260C-UNLIM	-40 to 85	(T3IS ~ T3IU)	Samples
TL431IDG4	ACTIVE	SOIC	D	8	75	Green (RoHS & no Sb/Br)	CU NIPDAU	Level-1-260C-UNLIM	-40 to 85	TL431I	Samples
TL431IDR	ACTIVE	SOIC	D	8	2500	Green (RoHS & no Sb/Br)	CU NIPDAU CU SN	Level-1-260C-UNLIM	-40 to 85	TL431I	Samples
TL431IDRG4	ACTIVE	SOIC	D	8	2500	Green (RoHS & no Sb/Br)	CU NIPDAU	Level-1-260C-UNLIM	-40 to 85	TL431I	Samples
TL431ILP	ACTIVE	TO-92	LP	3	1000	Pb-Free (RoHS)	CU SN	N / A for Pkg Type	-40 to 85	TL431I	Samples
TL431ILPM	OBSOLETE	TO-92	LP	3		TBD	Call TI	Call TI	-40 to 85		

Orderable Device	Status (1)	Package Type	Package Drawing	Pins	Package Qty	Eco Plan (2)	Lead/Ball Finish (6)	MSL Peak Temp (3)	Op Temp (°C)	Device Marking (4/5)	Samples
TL431ILPR	ACTIVE	TO-92	LP	3	2000	Pb-Free (RoHS)	CU SN	N / A for Pkg Type	-40 to 85	TL431I	Samples
TL431IP	ACTIVE	PDIP	P	8	50	Pb-Free (RoHS)	CU NIPDAU	N / A for Pkg Type	-40 to 85	TL431IP	Samples
TL431IPE4	ACTIVE	PDIP	P	8	50	Pb-Free (RoHS)	CU NIPDAU	N / A for Pkg Type	-40 to 85	TL431IP	Samples
TL431IPK	ACTIVE	SOT-89	PK	3	1000	Green (RoHS & no Sb/Br)	CU SN	Level-2-260C-1 YEAR	-40 to 85	3I	Samples
TL431IPKG3	ACTIVE	SOT-89	PK	3	1000	Green (RoHS & no Sb/Br)	CU SN	Level-2-260C-1 YEAR	-40 to 85	3I	Samples
TL431MFKB	OBSOLETE	LCCC	FK	20		TBD	Call TI	Call TI	-55 to 125		
TL431MJG	OBSOLETE	CDIP	JG	8		TBD	Call TI	Call TI	-55 to 125		
TL431MJGB	OBSOLETE	CDIP	JG	8		TBD	Call TI	Call TI	-55 to 125		
TL431QD	ACTIVE	SOIC	D	8	75	Green (RoHS & no Sb/Br)	CU NIPDAU	Level-1-260C-UNLIM	-40 to 125	T431Q	Samples
TL431QDBVR	ACTIVE	SOT-23	DBV	5	3000	Green (RoHS & no Sb/Br)	CU NIPDAU CU SN	Level-1-260C-UNLIM	-40 to 125	(T3QG ~ T3QU)	Samples
TL431QDBVRG4	ACTIVE	SOT-23	DBV	5	3000	Green (RoHS & no Sb/Br)	CU NIPDAU	Level-1-260C-UNLIM	-40 to 125	T3QG	Samples
TL431QDBVT	ACTIVE	SOT-23	DBV	5	250	Green (RoHS & no Sb/Br)	CU NIPDAU CU SN	Level-1-260C-UNLIM	-40 to 125	(T3QG ~ T3QU)	Samples
TL431QDBVTE4	ACTIVE	SOT-23	DBV	5		TBD	Call TI	Call TI	-40 to 125		Samples
TL431QDBZR	ACTIVE	SOT-23	DBZ	3	3000	Green (RoHS & no Sb/Br)	CU NIPDAU	Level-1-260C-UNLIM	-40 to 125	(T3Q3 ~ T3QS ~ T3QU)	Samples
TL431QDBZRG4	ACTIVE	SOT-23	DBZ	3	3000	Green (RoHS & no Sb/Br)	CU NIPDAU	Level-1-260C-UNLIM	-40 to 125	(T3Q3 ~ T3QS ~ T3QU)	Samples
TL431QDBZT	ACTIVE	SOT-23	DBZ	3	250	Green (RoHS & no Sb/Br)	CU NIPDAU	Level-1-260C-UNLIM	-40 to 125	(T3QS ~ T3QU)	Samples
TL431QDBZTG4	ACTIVE	SOT-23	DBZ	3	250	Green (RoHS & no Sb/Br)	CU NIPDAU	Level-1-260C-UNLIM	-40 to 125	(T3QS ~ T3QU)	Samples
TL431QDCKR	ACTIVE	SC70	DCK	6	3000	Green (RoHS & no Sb/Br)	CU NIPDAU	Level-1-260C-UNLIM	-40 to 125	T6U	Samples
TL431QDCKRG4	ACTIVE	SC70	DCK	6	3000	Green (RoHS & no Sb/Br)	CU NIPDAU	Level-1-260C-UNLIM	-40 to 125	T6U	Samples

Orderable Device	Status (1)	Package Type	Package Drawing	Pins	Package Qty	Eco Plan (2)	Lead/Ball Finish (6)	MSL Peak Temp (3)	Op Temp (°C)	Device Marking (4/5)	Samples
TL431QDCKT	ACTIVE	SC70	DCK	6	250	Green (RoHS & no Sb/Br)	CU NIPDAU	Level-1-260C-UNLIM	-40 to 125	T6U	Samples
TL431QDCKTG4	ACTIVE	SC70	DCK	6	250	Green (RoHS & no Sb/Br)	CU NIPDAU	Level-1-260C-UNLIM	-40 to 125	T6U	Samples
TL431QDR	ACTIVE	SOIC	D	8	2500	Green (RoHS & no Sb/Br)	CU NIPDAU	Level-1-260C-UNLIM	-40 to 125	T431Q	Samples
TL431QPK	ACTIVE	SOT-89	PK	3	1000	Green (RoHS & no Sb/Br)	CU SN	Level-2-260C-1 YEAR	-40 to 125	3Q	Samples
TL431QPKG3	ACTIVE	SOT-89	PK	3	1000	Green (RoHS & no Sb/Br)	CU SN	Level-2-260C-1 YEAR	-40 to 125	3Q	Samples
TL432ACDBVR	ACTIVE	SOT-23	DBV	5	3000	Green (RoHS & no Sb/Br)	CU NIPDAU CU SN	Level-1-260C-UNLIM	0 to 70	(T4BG ~ T4BU)	Samples
TL432ACDBZR	ACTIVE	SOT-23	DBZ	3	3000	Green (RoHS & no Sb/Br)	CU NIPDAU	Level-1-260C-UNLIM	0 to 70	(T4B3 ~ T4BS ~ T4BU)	Samples
TL432ACDBZRG4	ACTIVE	SOT-23	DBZ	3	3000	Green (RoHS & no Sb/Br)	CU NIPDAU	Level-1-260C-UNLIM	0 to 70	(T4B3 ~ T4BS ~ T4BU)	Samples
TL432ACDBZT	ACTIVE	SOT-23	DBZ	3	250	Green (RoHS & no Sb/Br)	CU NIPDAU	Level-1-260C-UNLIM	0 to 70	(T4BS ~ T4BU)	Samples
TL432ACDBZTG4	ACTIVE	SOT-23	DBZ	3	250	Green (RoHS & no Sb/Br)	CU NIPDAU	Level-1-260C-UNLIM	0 to 70	(T4BS ~ T4BU)	Samples
TL432AIDBVR	ACTIVE	SOT-23	DBV	5	3000	Green (RoHS & no Sb/Br)	CU NIPDAU CU SN	Level-1-260C-UNLIM	-40 to 85	(T4AG ~ T4AU)	Samples
TL432AIDBZR	ACTIVE	SOT-23	DBZ	3	3000	Green (RoHS & no Sb/Br)	CU NIPDAU	Level-1-260C-UNLIM	-40 to 85	(T4A3 ~ T4AS ~ T4AU)	Samples
TL432AIDBZRG4	ACTIVE	SOT-23	DBZ	3	3000	Green (RoHS & no Sb/Br)	CU NIPDAU	Level-1-260C-UNLIM	-40 to 85	(T4A3 ~ T4AS ~ T4AU)	Samples
TL432AIDBZT	ACTIVE	SOT-23	DBZ	3	250	Green (RoHS & no Sb/Br)	CU NIPDAU	Level-1-260C-UNLIM	-40 to 85	(T4A3 ~ T4AS ~ T4AU)	Samples
TL432AIDBZTG4	ACTIVE	SOT-23	DBZ	3	250	Green (RoHS & no Sb/Br)	CU NIPDAU	Level-1-260C-UNLIM	-40 to 85	(T4A3 ~ T4AS ~ T4AU)	Samples
TL432AIPK	ACTIVE	SOT-89	PK	3	1000	Green (RoHS & no Sb/Br)	CU SN	Level-2-260C-1 YEAR	-40 to 85	2E	Samples
TL432AQDBVR	ACTIVE	SOT-23	DBV	5	3000	Green (RoHS & no Sb/Br)	CU NIPDAU	Level-1-260C-UNLIM	-40 to 125	T4DU	Samples
TL432AQDBVT	ACTIVE	SOT-23	DBV	5	250	Green (RoHS & no Sb/Br)	CU NIPDAU	Level-1-260C-UNLIM	-40 to 125	T4DU	Samples

Orderable Device	Status (1)	Package Type	Package Drawing	Pins	Package Qty	Eco Plan (2)	Lead/Ball Finish (6)	MSL Peak Temp (3)	Op Temp (°C)	Device Marking (4/5)	Samples
TL432AQDBVTG4	ACTIVE	SOT-23	DBV	5	250	Green (RoHS & no Sb/Br)	CU NIPDAU	Level-1-260C-UNLIM	-40 to 125	T4DU	Samples
TL432AQDBZR	ACTIVE	SOT-23	DBZ	3	3000	Green (RoHS & no Sb/Br)	CU NIPDAU	Level-1-260C-UNLIM	-40 to 125	(T4D3 ~ T4DS ~ T4DU)	Samples
TL432AQDBZRG4	ACTIVE	SOT-23	DBZ	3	3000	Green (RoHS & no Sb/Br)	CU NIPDAU	Level-1-260C-UNLIM	-40 to 125	(T4D3 ~ T4DS ~ T4DU)	Samples
TL432AQDBZT	ACTIVE	SOT-23	DBZ	3	250	Green (RoHS & no Sb/Br)	CU NIPDAU	Level-1-260C-UNLIM	-40 to 125	(T4DS ~ T4DU)	Samples
TL432AQDBZTG4	ACTIVE	SOT-23	DBZ	3	250	Green (RoHS & no Sb/Br)	CU NIPDAU	Level-1-260C-UNLIM	-40 to 125	(T4DS ~ T4DU)	Samples
TL432AQPCK	ACTIVE	SOT-89	PK	3	1000	Green (RoHS & no Sb/Br)	CU SN	Level-2-260C-1 YEAR	-40 to 125	2F	Samples
TL432AQPCKG3	ACTIVE	SOT-89	PK	3	1000	Green (RoHS & no Sb/Br)	CU SN	Level-2-260C-1 YEAR	-40 to 125	2F	Samples
TL432BCDBVR	ACTIVE	SOT-23	DBV	5	3000	Green (RoHS & no Sb/Br)	CU NIPDAU	Level-1-260C-UNLIM	0 to 70	(TBC3 ~ TBCU)	Samples
TL432BCDBZR	ACTIVE	SOT-23	DBZ	3	3000	Green (RoHS & no Sb/Br)	CU NIPDAU	Level-1-260C-UNLIM	0 to 70	(TBCS ~ TBCU)	Samples
TL432BCDBZT	ACTIVE	SOT-23	DBZ	3	250	Green (RoHS & no Sb/Br)	CU NIPDAU	Level-1-260C-UNLIM	0 to 70	(TBCS ~ TBCU)	Samples
TL432BCDBZTG4	ACTIVE	SOT-23	DBZ	3	250	Green (RoHS & no Sb/Br)	CU NIPDAU	Level-1-260C-UNLIM	0 to 70	(TBCS ~ TBCU)	Samples
TL432BCPK	ACTIVE	SOT-89	PK	3	1000	Green (RoHS & no Sb/Br)	CU SN	Level-2-260C-1 YEAR	0 to 70	2G	Samples
TL432BIDBZR	ACTIVE	SOT-23	DBZ	3	3000	Green (RoHS & no Sb/Br)	CU NIPDAU	Level-1-260C-UNLIM	-40 to 85	(T4F3 ~ T4FS ~ T4FU)	Samples
TL432BIDBZRG4	ACTIVE	SOT-23	DBZ	3	3000	Green (RoHS & no Sb/Br)	CU NIPDAU	Level-1-260C-UNLIM	-40 to 85	(T4F3 ~ T4FS ~ T4FU)	Samples
TL432BIDBZT	ACTIVE	SOT-23	DBZ	3	250	Green (RoHS & no Sb/Br)	CU NIPDAU	Level-1-260C-UNLIM	-40 to 85	(T4F3 ~ T4FS ~ T4FU)	Samples
TL432BIDBZTG4	ACTIVE	SOT-23	DBZ	3	250	Green (RoHS & no Sb/Br)	CU NIPDAU	Level-1-260C-UNLIM	-40 to 85	(T4F3 ~ T4FS ~ T4FU)	Samples
TL432BIPK	ACTIVE	SOT-89	PK	3	1000	Green (RoHS & no Sb/Br)	CU SN	Level-2-260C-1 YEAR	-40 to 85	2H	Samples
TL432BQDBZR	ACTIVE	SOT-23	DBZ	3	3000	Green (RoHS & no Sb/Br)	CU NIPDAU	Level-1-260C-UNLIM	-40 to 125	(T4H3 ~ T4HS ~ T4HU)	Samples

Orderable Device	Status (1)	Package Type	Package Drawing	Pins	Package Qty	Eco Plan (2)	Lead/Ball Finish (6)	MSL Peak Temp (3)	Op Temp (°C)	Device Marking (4/5)	Samples
TL432BQDBZRG4	ACTIVE	SOT-23	DBZ	3	3000	Green (RoHS & no Sb/Br)	CU NIPDAU	Level-1-260C-UNLIM	-40 to 125	(T4H3 ~ T4HS ~ T4HU)	Samples
TL432BQDBZT	PREVIEW	SOT-23	DBZ	3	250	TBD	Call TI	Call TI	-40 to 125		
TL432BQPK	ACTIVE	SOT-89	PK	3	1000	Green (RoHS & no Sb/Br)	CU SN	Level-2-260C-1 YEAR	-40 to 125	2J	Samples
TL432CDBVR	ACTIVE	SOT-23	DBV	5	3000	Green (RoHS & no Sb/Br)	CU NIPDAU CU SN	Level-1-260C-UNLIM	0 to 70	(T4CG ~ T4CU)	Samples
TL432CDBZR	ACTIVE	SOT-23	DBZ	3	3000	Green (RoHS & no Sb/Br)	CU NIPDAU	Level-1-260C-UNLIM	0 to 70	(T4CS ~ T4CU)	Samples
TL432CDBZT	ACTIVE	SOT-23	DBZ	3	250	Green (RoHS & no Sb/Br)	CU NIPDAU	Level-1-260C-UNLIM	0 to 70	(T4CS ~ T4CU)	Samples
TL432CDBZTG4	ACTIVE	SOT-23	DBZ	3	250	Green (RoHS & no Sb/Br)	CU NIPDAU	Level-1-260C-UNLIM	0 to 70	(T4CS ~ T4CU)	Samples
TL432CPK	ACTIVE	SOT-89	PK	3	1000	Green (RoHS & no Sb/Br)	CU SN	Level-2-260C-1 YEAR	0 to 70	2A	Samples
TL432IDBVR	ACTIVE	SOT-23	DBV	5	3000	Green (RoHS & no Sb/Br)	CU NIPDAU CU SN	Level-1-260C-UNLIM	-40 to 85	(T4IG ~ T4IU)	Samples
TL432IDBZR	ACTIVE	SOT-23	DBZ	3	3000	Green (RoHS & no Sb/Br)	CU NIPDAU	Level-1-260C-UNLIM	-40 to 85	(T4IS ~ T4IU)	Samples
TL432IDBZT	ACTIVE	SOT-23	DBZ	3	250	Green (RoHS & no Sb/Br)	CU NIPDAU	Level-1-260C-UNLIM	-40 to 85	(T4IS ~ T4IU)	Samples
TL432IPK	ACTIVE	SOT-89	PK	3	1000	Green (RoHS & no Sb/Br)	CU SN	Level-2-260C-1 YEAR	-40 to 85	2B	Samples
TL432QDBZR	ACTIVE	SOT-23	DBZ	3	3000	Green (RoHS & no Sb/Br)	CU NIPDAU	Level-1-260C-UNLIM	-40 to 125	(T4QS ~ T4QU)	Samples
TL432QPK	ACTIVE	SOT-89	PK	3	1000	Green (RoHS & no Sb/Br)	CU SN	Level-2-260C-1 YEAR	-40 to 125	2C	Samples
TL432QPKG3	ACTIVE	SOT-89	PK	3	1000	Green (RoHS & no Sb/Br)	CU SN	Level-2-260C-1 YEAR	-40 to 125	2C	Samples

(1) The marketing status values are defined as follows:

ACTIVE: Product device recommended for new designs.

LIFEBUY: TI has announced that the device will be discontinued, and a lifetime-buy period is in effect.

NRND: Not recommended for new designs. Device is in production to support existing customers, but TI does not recommend using this part in a new design.

PREVIEW: Device has been announced but is not in production. Samples may or may not be available.

OBSELETE: TI has discontinued the production of the device.

(2) Eco Plan - The planned eco-friendly classification: Pb-Free (RoHS), Pb-Free (RoHS Exempt), or Green (RoHS & no Sb/Br) - please check <http://www.ti.com/productcontent> for the latest availability information and additional product content details.

TBD: The Pb-Free/Green conversion plan has not been defined.

Pb-Free (RoHS): TI's terms "Lead-Free" or "Pb-Free" mean semiconductor products that are compatible with the current RoHS requirements for all 6 substances, including the requirement that lead not exceed 0.1% by weight in homogeneous materials. Where designed to be soldered at high temperatures, TI Pb-Free products are suitable for use in specified lead-free processes.

Pb-Free (RoHS Exempt): This component has a RoHS exemption for either 1) lead-based flip-chip solder bumps used between the die and package, or 2) lead-based die adhesive used between the die and leadframe. The component is otherwise considered Pb-Free (RoHS compatible) as defined above.

Green (RoHS & no Sb/Br): TI defines "Green" to mean Pb-Free (RoHS compatible), and free of Bromine (Br) and Antimony (Sb) based flame retardants (Br or Sb do not exceed 0.1% by weight in homogeneous material)

(3) MSL, Peak Temp. - The Moisture Sensitivity Level rating according to the JEDEC industry standard classifications, and peak solder temperature.

(4) There may be additional marking, which relates to the logo, the lot trace code information, or the environmental category on the device.

(5) Multiple Device Markings will be inside parentheses. Only one Device Marking contained in parentheses and separated by a "~" will appear on a device. If a line is indented then it is a continuation of the previous line and the two combined represent the entire Device Marking for that device.

(6) Lead/Ball Finish - Orderable Devices may have multiple material finish options. Finish options are separated by a vertical ruled line. Lead/Ball Finish values may wrap to two lines if the finish value exceeds the maximum column width.

Important Information and Disclaimer: The information provided on this page represents TI's knowledge and belief as of the date that it is provided. TI bases its knowledge and belief on information provided by third parties, and makes no representation or warranty as to the accuracy of such information. Efforts are underway to better integrate information from third parties. TI has taken and continues to take reasonable steps to provide representative and accurate information but may not have conducted destructive testing or chemical analysis on incoming materials and chemicals. TI and TI suppliers consider certain information to be proprietary, and thus CAS numbers and other limited information may not be available for release.

In no event shall TI's liability arising out of such information exceed the total purchase price of the TI part(s) at issue in this document sold by TI to Customer on an annual basis.

OTHER QUALIFIED VERSIONS OF TL431A, TL431B, TL432A, TL432B :

- Automotive: [TL431A-Q1](#), [TL431B-Q1](#), [TL432A-Q1](#), [TL432B-Q1](#)

NOTE: Qualified Version Definitions:

- Automotive - Q100 devices qualified for high-reliability automotive applications targeting zero defects

TAPE AND REEL INFORMATION

QUADRANT ASSIGNMENTS FOR PIN 1 ORIENTATION IN TAPE

*All dimensions are nominal

Device	Package Type	Package Drawing	Pins	SPQ	Reel Diameter (mm)	Reel Width W1 (mm)	A0 (mm)	B0 (mm)	K0 (mm)	P1 (mm)	W (mm)	Pin1 Quadrant
TL431ACDBVR	SOT-23	DBV	5	3000	180.0	8.4	3.23	3.17	1.37	4.0	8.0	Q3
TL431ACDBVR	SOT-23	DBV	5	3000	178.0	9.0	3.3	3.2	1.4	4.0	8.0	Q3
TL431ACDBVRG4	SOT-23	DBV	5	3000	178.0	9.0	3.3	3.2	1.4	4.0	8.0	Q3
TL431ACDBVT	SOT-23	DBV	5	250	178.0	9.0	3.23	3.17	1.37	4.0	8.0	Q3
TL431ACDBZR	SOT-23	DBZ	3	3000	178.0	9.2	3.08	2.8	1.27	4.0	8.0	Q3
TL431ACDBZR	SOT-23	DBZ	3	3000	180.0	8.4	3.15	2.77	1.22	4.0	8.0	Q3
TL431ACDBZT	SOT-23	DBZ	3	250	178.0	9.2	3.08	2.8	1.27	4.0	8.0	Q3
TL431ACDBZT	SOT-23	DBZ	3	250	180.0	8.4	3.15	2.77	1.22	4.0	8.0	Q3
TL431ACDCKR	SC70	DCK	6	3000	180.0	8.4	2.41	2.41	1.2	4.0	8.0	Q3
TL431ACDR	SOIC	D	8	2500	330.0	12.4	6.4	5.2	2.1	8.0	12.0	Q1
TL431ACPK	SOT-89	PK	3	1000	180.0	12.4	4.91	4.52	1.9	8.0	12.0	Q3
TL431ACPSR	SO	PS	8	2000	330.0	16.4	8.2	6.6	2.5	12.0	16.0	Q1
TL431AIDBVR	SOT-23	DBV	5	3000	178.0	9.0	3.23	3.17	1.37	4.0	8.0	Q3
TL431AIDBVR	SOT-23	DBV	5	3000	180.0	8.4	3.23	3.17	1.37	4.0	8.0	Q3
TL431AIDBVRG4	SOT-23	DBV	5	3000	178.0	9.0	3.23	3.17	1.37	4.0	8.0	Q3
TL431AIDBVT	SOT-23	DBV	5	250	178.0	9.0	3.23	3.17	1.37	4.0	8.0	Q3
TL431AIDBVTG4	SOT-23	DBV	5	250	178.0	9.0	3.23	3.17	1.37	4.0	8.0	Q3
TL431AIDBZR	SOT-23	DBZ	3	3000	178.0	9.2	3.08	2.8	1.27	4.0	8.0	Q3

Device	Package Type	Package Drawing	Pins	SPQ	Reel Diameter (mm)	Reel Width W1 (mm)	A0 (mm)	B0 (mm)	K0 (mm)	P1 (mm)	W (mm)	Pin1 Quadrant
TL431AIDBZR	SOT-23	DBZ	3	3000	180.0	8.4	3.15	2.77	1.22	4.0	8.0	Q3
TL431AIDBZT	SOT-23	DBZ	3	250	178.0	9.2	3.08	2.8	1.27	4.0	8.0	Q3
TL431AIDBZT	SOT-23	DBZ	3	250	180.0	8.4	3.15	2.77	1.22	4.0	8.0	Q3
TL431AIDCKR	SC70	DCK	6	3000	179.0	8.4	2.2	2.5	1.2	4.0	8.0	Q3
TL431AIDCKT	SC70	DCK	6	250	179.0	8.4	2.2	2.5	1.2	4.0	8.0	Q3
TL431AIDR	SOIC	D	8	2500	330.0	12.4	6.4	5.2	2.1	8.0	12.0	Q1
TL431AIPK	SOT-89	PK	3	1000	180.0	12.4	4.91	4.52	1.9	8.0	12.0	Q3
TL431AQDBVR	SOT-23	DBV	5	3000	178.0	9.0	3.23	3.17	1.37	4.0	8.0	Q3
TL431AQDBVT	SOT-23	DBV	5	250	178.0	9.0	3.3	3.2	1.4	4.0	8.0	Q3
TL431AQDBZR	SOT-23	DBZ	3	3000	180.0	8.4	3.15	2.77	1.22	4.0	8.0	Q3
TL431AQDBZT	SOT-23	DBZ	3	250	180.0	8.4	3.15	2.77	1.22	4.0	8.0	Q3
TL431AQDCKR	SC70	DCK	6	3000	179.0	8.4	2.2	2.5	1.2	4.0	8.0	Q3
TL431AQDCKT	SC70	DCK	6	250	179.0	8.4	2.2	2.5	1.2	4.0	8.0	Q3
TL431BCDBVR	SOT-23	DBV	5	3000	179.0	8.4	3.2	3.2	1.4	4.0	8.0	Q3
TL431BCDBVT	SOT-23	DBV	5	250	179.0	8.4	3.2	3.2	1.4	4.0	8.0	Q3
TL431BCDBVTG4	SOT-23	DBV	5	250	178.0	9.0	3.23	3.17	1.37	4.0	8.0	Q3
TL431BCDBZR	SOT-23	DBZ	3	3000	180.0	8.4	3.15	2.77	1.22	4.0	8.0	Q3
TL431BCDBZR	SOT-23	DBZ	3	3000	178.0	9.2	3.08	2.8	1.27	4.0	8.0	Q3
TL431BCDBZT	SOT-23	DBZ	3	250	178.0	9.2	3.08	2.8	1.27	4.0	8.0	Q3
TL431BCDBZT	SOT-23	DBZ	3	250	180.0	8.4	3.15	2.77	1.22	4.0	8.0	Q3
TL431BCDCKR	SC70	DCK	6	3000	179.0	8.4	2.2	2.5	1.2	4.0	8.0	Q3
TL431BCDCKT	SC70	DCK	6	250	179.0	8.4	2.2	2.5	1.2	4.0	8.0	Q3
TL431BCDR	SOIC	D	8	2500	330.0	12.4	6.4	5.2	2.1	8.0	12.0	Q1
TL431BCPK	SOT-89	PK	3	1000	180.0	12.4	4.91	4.52	1.9	8.0	12.0	Q3
TL431BCPSR	SO	PS	8	2000	330.0	16.4	8.2	6.6	2.5	12.0	16.0	Q1
TL431BIDBVR	SOT-23	DBV	5	3000	179.0	8.4	3.2	3.2	1.4	4.0	8.0	Q3
TL431BIDBVR	SOT-23	DBV	5	3000	178.0	9.0	3.23	3.17	1.37	4.0	8.0	Q3
TL431BIDBVT	SOT-23	DBV	5	250	178.0	9.0	3.23	3.17	1.37	4.0	8.0	Q3
TL431BIDBVT	SOT-23	DBV	5	250	179.0	8.4	3.2	3.2	1.4	4.0	8.0	Q3
TL431BIDBVTG4	SOT-23	DBV	5	250	178.0	9.0	3.23	3.17	1.37	4.0	8.0	Q3
TL431BIDBZR	SOT-23	DBZ	3	3000	178.0	9.2	3.08	2.8	1.27	4.0	8.0	Q3
TL431BIDBZR	SOT-23	DBZ	3	3000	180.0	8.4	3.15	2.77	1.22	4.0	8.0	Q3
TL431BIDBZT	SOT-23	DBZ	3	250	180.0	8.4	3.15	2.77	1.22	4.0	8.0	Q3
TL431BIDBZT	SOT-23	DBZ	3	250	178.0	9.2	3.08	2.8	1.27	4.0	8.0	Q3
TL431BIDCKR	SC70	DCK	6	3000	179.0	8.4	2.2	2.5	1.2	4.0	8.0	Q3
TL431BIDCKT	SC70	DCK	6	250	179.0	8.4	2.2	2.5	1.2	4.0	8.0	Q3
TL431BIDR	SOIC	D	8	2500	330.0	12.4	6.4	5.2	2.1	8.0	12.0	Q1
TL431BIDR	SOIC	D	8	2500	330.0	12.8	6.4	5.2	2.1	8.0	12.0	Q1
TL431BIDRG4	SOIC	D	8	2500	330.0	12.4	6.4	5.2	2.1	8.0	12.0	Q1
TL431BIPK	SOT-89	PK	3	1000	180.0	12.4	4.91	4.52	1.9	8.0	12.0	Q3
TL431BQDBVR	SOT-23	DBV	5	3000	179.0	8.4	3.2	3.2	1.4	4.0	8.0	Q3
TL431BQDBVT	SOT-23	DBV	5	250	179.0	8.4	3.2	3.2	1.4	4.0	8.0	Q3
TL431BQDBZR	SOT-23	DBZ	3	3000	180.0	8.4	3.15	2.77	1.22	4.0	8.0	Q3

Device	Package Type	Package Drawing	Pins	SPQ	Reel Diameter (mm)	Reel Width W1 (mm)	A0 (mm)	B0 (mm)	K0 (mm)	P1 (mm)	W (mm)	Pin1 Quadrant
TL431BQDBZT	SOT-23	DBZ	3	250	180.0	8.4	3.15	2.77	1.22	4.0	8.0	Q3
TL431BQDCKR	SC70	DCK	6	3000	179.0	8.4	2.2	2.5	1.2	4.0	8.0	Q3
TL431BQDCKT	SC70	DCK	6	250	179.0	8.4	2.2	2.5	1.2	4.0	8.0	Q3
TL431BQDR	SOIC	D	8	2500	330.0	12.4	6.4	5.2	2.1	8.0	12.0	Q1
TL431CDBVR	SOT-23	DBV	5	3000	178.0	9.0	3.23	3.17	1.37	4.0	8.0	Q3
TL431CDBVR	SOT-23	DBV	5	3000	180.0	8.4	3.23	3.17	1.37	4.0	8.0	Q3
TL431CDBVT	SOT-23	DBV	5	250	180.0	8.4	3.23	3.17	1.37	4.0	8.0	Q3
TL431CDBVTG4	SOT-23	DBV	5	250	178.0	9.0	3.23	3.17	1.37	4.0	8.0	Q3
TL431CDBZR	SOT-23	DBZ	3	3000	180.0	8.4	3.15	2.77	1.22	4.0	8.0	Q3
TL431CDBZT	SOT-23	DBZ	3	250	180.0	8.4	3.15	2.77	1.22	4.0	8.0	Q3
TL431CDR	SOIC	D	8	2500	330.0	12.8	6.4	5.2	2.1	8.0	12.0	Q1
TL431CDR	SOIC	D	8	2500	330.0	12.4	6.4	5.2	2.1	8.0	12.0	Q1
TL431CDRG4	SOIC	D	8	2500	330.0	12.4	6.4	5.2	2.1	8.0	12.0	Q1
TL431CPK	SOT-89	PK	3	1000	180.0	12.4	4.91	4.52	1.9	8.0	12.0	Q3
TL431CPSR	SO	PS	8	2000	330.0	16.4	8.2	6.6	2.5	12.0	16.0	Q1
TL431IDBVR	SOT-23	DBV	5	3000	178.0	9.0	3.23	3.17	1.37	4.0	8.0	Q3
TL431IDBVR	SOT-23	DBV	5	3000	180.0	8.4	3.23	3.17	1.37	4.0	8.0	Q3
TL431IDBVRG4	SOT-23	DBV	5	3000	178.0	9.0	3.23	3.17	1.37	4.0	8.0	Q3
TL431IDBVT	SOT-23	DBV	5	250	178.0	9.0	3.23	3.17	1.37	4.0	8.0	Q3
TL431IDBZR	SOT-23	DBZ	3	3000	180.0	8.4	3.15	2.77	1.22	4.0	8.0	Q3
TL431IDBZT	SOT-23	DBZ	3	250	180.0	8.4	3.15	2.77	1.22	4.0	8.0	Q3
TL431IDR	SOIC	D	8	2500	330.0	12.8	6.4	5.2	2.1	8.0	12.0	Q1
TL431IDR	SOIC	D	8	2500	330.0	12.4	6.4	5.2	2.1	8.0	12.0	Q1
TL431IDRG4	SOIC	D	8	2500	330.0	12.4	6.4	5.2	2.1	8.0	12.0	Q1
TL431IPK	SOT-89	PK	3	1000	180.0	12.4	4.91	4.52	1.9	8.0	12.0	Q3
TL431QDBVR	SOT-23	DBV	5	3000	178.0	9.0	3.23	3.17	1.37	4.0	8.0	Q3
TL431QDBVT	SOT-23	DBV	5	250	178.0	9.0	3.23	3.17	1.37	4.0	8.0	Q3
TL431QDBZR	SOT-23	DBZ	3	3000	180.0	8.4	3.15	2.77	1.22	4.0	8.0	Q3
TL431QDBZT	SOT-23	DBZ	3	250	180.0	8.4	3.15	2.77	1.22	4.0	8.0	Q3
TL431QDCKR	SC70	DCK	6	3000	179.0	8.4	2.2	2.5	1.2	4.0	8.0	Q3
TL431QDCKT	SC70	DCK	6	250	179.0	8.4	2.2	2.5	1.2	4.0	8.0	Q3
TL431QDR	SOIC	D	8	2500	330.0	12.4	6.4	5.2	2.1	8.0	12.0	Q1
TL432ACDBVR	SOT-23	DBV	5	3000	178.0	9.0	3.23	3.17	1.37	4.0	8.0	Q3
TL432ACDBZR	SOT-23	DBZ	3	3000	180.0	8.4	3.15	2.77	1.22	4.0	8.0	Q3
TL432ACDBZT	SOT-23	DBZ	3	250	180.0	8.4	3.15	2.77	1.22	4.0	8.0	Q3
TL432AIDBVR	SOT-23	DBV	5	3000	178.0	9.0	3.23	3.17	1.37	4.0	8.0	Q3
TL432AIDBZR	SOT-23	DBZ	3	3000	178.0	9.2	3.08	2.8	1.27	4.0	8.0	Q3
TL432AIDBZR	SOT-23	DBZ	3	3000	180.0	8.4	3.15	2.77	1.22	4.0	8.0	Q3
TL432AIDBZT	SOT-23	DBZ	3	250	180.0	8.4	3.15	2.77	1.22	4.0	8.0	Q3
TL432AIDBZT	SOT-23	DBZ	3	250	178.0	9.2	3.08	2.8	1.27	4.0	8.0	Q3
TL432AIPK	SOT-89	PK	3	1000	180.0	12.4	4.91	4.52	1.9	8.0	12.0	Q3
TL432AQDBVR	SOT-23	DBV	5	3000	179.0	8.4	3.2	3.2	1.4	4.0	8.0	Q3
TL432AQDBVT	SOT-23	DBV	5	250	179.0	8.4	3.2	3.2	1.4	4.0	8.0	Q3

Device	Package Type	Package Drawing	Pins	SPQ	Reel Diameter (mm)	Reel Width W1 (mm)	A0 (mm)	B0 (mm)	K0 (mm)	P1 (mm)	W (mm)	Pin1 Quadrant
TL432AQDBZR	SOT-23	DBZ	3	3000	180.0	8.4	3.15	2.77	1.22	4.0	8.0	Q3
TL432AQDBZT	SOT-23	DBZ	3	250	180.0	8.4	3.15	2.77	1.22	4.0	8.0	Q3
TL432AQP	SOT-89	PK	3	1000	180.0	12.4	4.91	4.52	1.9	8.0	12.0	Q3
TL432BCDBVR	SOT-23	DBV	5	3000	179.0	8.4	3.2	3.2	1.4	4.0	8.0	Q3
TL432BCDBZR	SOT-23	DBZ	3	3000	180.0	8.4	3.15	2.77	1.22	4.0	8.0	Q3
TL432BCDBZT	SOT-23	DBZ	3	250	180.0	8.4	3.15	2.77	1.22	4.0	8.0	Q3
TL432BCPK	SOT-89	PK	3	1000	180.0	12.4	4.91	4.52	1.9	8.0	12.0	Q3
TL432BIDBZR	SOT-23	DBZ	3	3000	180.0	8.4	3.15	2.77	1.22	4.0	8.0	Q3
TL432BIDBZR	SOT-23	DBZ	3	3000	178.0	9.2	3.08	2.8	1.27	4.0	8.0	Q3
TL432BIDBZT	SOT-23	DBZ	3	250	180.0	8.4	3.15	2.77	1.22	4.0	8.0	Q3
TL432BIDBZT	SOT-23	DBZ	3	250	178.0	9.2	3.08	2.8	1.27	4.0	8.0	Q3
TL432BIPK	SOT-89	PK	3	1000	180.0	12.4	4.91	4.52	1.9	8.0	12.0	Q3
TL432BQDBZR	SOT-23	DBZ	3	3000	178.0	9.2	3.08	2.8	1.27	4.0	8.0	Q3
TL432BQDBZR	SOT-23	DBZ	3	3000	180.0	8.4	3.15	2.77	1.22	4.0	8.0	Q3
TL432BQPK	SOT-89	PK	3	1000	180.0	12.4	4.91	4.52	1.9	8.0	12.0	Q3
TL432CDBVR	SOT-23	DBV	5	3000	178.0	9.0	3.23	3.17	1.37	4.0	8.0	Q3
TL432CDBZR	SOT-23	DBZ	3	3000	180.0	8.4	3.15	2.77	1.22	4.0	8.0	Q3
TL432CDBZT	SOT-23	DBZ	3	250	180.0	8.4	3.15	2.77	1.22	4.0	8.0	Q3
TL432CPK	SOT-89	PK	3	1000	180.0	12.4	4.91	4.52	1.9	8.0	12.0	Q3
TL432IDBVR	SOT-23	DBV	5	3000	179.0	8.4	3.2	3.2	1.4	4.0	8.0	Q3
TL432IDBVR	SOT-23	DBV	5	3000	178.0	9.0	3.23	3.17	1.37	4.0	8.0	Q3
TL432IDBZR	SOT-23	DBZ	3	3000	180.0	8.4	3.15	2.77	1.22	4.0	8.0	Q3
TL432IDBZT	SOT-23	DBZ	3	250	180.0	8.4	3.15	2.77	1.22	4.0	8.0	Q3
TL432IPK	SOT-89	PK	3	1000	180.0	12.4	4.91	4.52	1.9	8.0	12.0	Q3
TL432QDBZR	SOT-23	DBZ	3	3000	180.0	8.4	3.15	2.77	1.22	4.0	8.0	Q3
TL432QPK	SOT-89	PK	3	1000	180.0	12.4	4.91	4.52	1.9	8.0	12.0	Q3

TAPE AND REEL BOX DIMENSIONS

*All dimensions are nominal

Device	Package Type	Package Drawing	Pins	SPQ	Length (mm)	Width (mm)	Height (mm)
TL431ACDBVR	SOT-23	DBV	5	3000	202.0	201.0	28.0
TL431ACDBVR	SOT-23	DBV	5	3000	180.0	180.0	18.0
TL431ACDBVRG4	SOT-23	DBV	5	3000	180.0	180.0	18.0
TL431ACDBVT	SOT-23	DBV	5	250	180.0	180.0	18.0
TL431ACDBZR	SOT-23	DBZ	3	3000	180.0	180.0	18.0
TL431ACDBZR	SOT-23	DBZ	3	3000	202.0	201.0	28.0
TL431ACDBZT	SOT-23	DBZ	3	250	180.0	180.0	18.0
TL431ACDBZT	SOT-23	DBZ	3	250	202.0	201.0	28.0
TL431ACDCKR	SC70	DCK	6	3000	202.0	201.0	28.0
TL431ACDR	SOIC	D	8	2500	340.5	338.1	20.6
TL431ACPK	SOT-89	PK	3	1000	340.0	340.0	38.0
TL431ACPSR	SO	PS	8	2000	367.0	367.0	38.0
TL431AIDBVR	SOT-23	DBV	5	3000	180.0	180.0	18.0
TL431AIDBVR	SOT-23	DBV	5	3000	202.0	201.0	28.0
TL431AIDBVRG4	SOT-23	DBV	5	3000	180.0	180.0	18.0
TL431AIDBVT	SOT-23	DBV	5	250	180.0	180.0	18.0
TL431AIDBVTG4	SOT-23	DBV	5	250	180.0	180.0	18.0
TL431AIDBZR	SOT-23	DBZ	3	3000	180.0	180.0	18.0
TL431AIDBZR	SOT-23	DBZ	3	3000	202.0	201.0	28.0
TL431AIDBZT	SOT-23	DBZ	3	250	180.0	180.0	18.0

Device	Package Type	Package Drawing	Pins	SPQ	Length (mm)	Width (mm)	Height (mm)
TL431AIDBZT	SOT-23	DBZ	3	250	202.0	201.0	28.0
TL431AIDCKR	SC70	DCK	6	3000	203.0	203.0	35.0
TL431AIDCKT	SC70	DCK	6	250	203.0	203.0	35.0
TL431AIDR	SOIC	D	8	2500	340.5	338.1	20.6
TL431AIPK	SOT-89	PK	3	1000	340.0	340.0	38.0
TL431AQDBVR	SOT-23	DBV	5	3000	180.0	180.0	18.0
TL431AQDBVT	SOT-23	DBV	5	250	180.0	180.0	18.0
TL431AQDBZR	SOT-23	DBZ	3	3000	202.0	201.0	28.0
TL431AQDBZT	SOT-23	DBZ	3	250	202.0	201.0	28.0
TL431AQDCKR	SC70	DCK	6	3000	203.0	203.0	35.0
TL431AQDCKT	SC70	DCK	6	250	203.0	203.0	35.0
TL431BCDBVR	SOT-23	DBV	5	3000	203.0	203.0	35.0
TL431BCDBVT	SOT-23	DBV	5	250	203.0	203.0	35.0
TL431BCDBVTG4	SOT-23	DBV	5	250	180.0	180.0	18.0
TL431BCDBZR	SOT-23	DBZ	3	3000	202.0	201.0	28.0
TL431BCDBZR	SOT-23	DBZ	3	3000	180.0	180.0	18.0
TL431BCDBZT	SOT-23	DBZ	3	250	180.0	180.0	18.0
TL431BCDBZT	SOT-23	DBZ	3	250	202.0	201.0	28.0
TL431BCDCKR	SC70	DCK	6	3000	203.0	203.0	35.0
TL431BCDCKT	SC70	DCK	6	250	203.0	203.0	35.0
TL431BCDR	SOIC	D	8	2500	340.5	338.1	20.6
TL431BCPK	SOT-89	PK	3	1000	340.0	340.0	38.0
TL431BCPSR	SO	PS	8	2000	367.0	367.0	38.0
TL431BIDBVR	SOT-23	DBV	5	3000	203.0	203.0	35.0
TL431BIDBVR	SOT-23	DBV	5	3000	180.0	180.0	18.0
TL431BIDBVT	SOT-23	DBV	5	250	180.0	180.0	18.0
TL431BIDBVT	SOT-23	DBV	5	250	203.0	203.0	35.0
TL431BIDBVTG4	SOT-23	DBV	5	250	180.0	180.0	18.0
TL431BIDBZR	SOT-23	DBZ	3	3000	180.0	180.0	18.0
TL431BIDBZR	SOT-23	DBZ	3	3000	202.0	201.0	28.0
TL431BIDBZT	SOT-23	DBZ	3	250	202.0	201.0	28.0
TL431BIDBZT	SOT-23	DBZ	3	250	180.0	180.0	18.0
TL431BIDCKR	SC70	DCK	6	3000	203.0	203.0	35.0
TL431BIDCKT	SC70	DCK	6	250	203.0	203.0	35.0
TL431BIDR	SOIC	D	8	2500	340.5	338.1	20.6
TL431BIDR	SOIC	D	8	2500	364.0	364.0	27.0
TL431BIDRG4	SOIC	D	8	2500	340.5	338.1	20.6
TL431BIPK	SOT-89	PK	3	1000	340.0	340.0	38.0
TL431BQDBVR	SOT-23	DBV	5	3000	203.0	203.0	35.0
TL431BQDBVT	SOT-23	DBV	5	250	203.0	203.0	35.0
TL431BQDBZR	SOT-23	DBZ	3	3000	202.0	201.0	28.0
TL431BQDBZT	SOT-23	DBZ	3	250	202.0	201.0	28.0
TL431BQDCKR	SC70	DCK	6	3000	203.0	203.0	35.0
TL431BQDCKT	SC70	DCK	6	250	203.0	203.0	35.0

Device	Package Type	Package Drawing	Pins	SPQ	Length (mm)	Width (mm)	Height (mm)
TL431BQDR	SOIC	D	8	2500	340.5	338.1	20.6
TL431CDBVR	SOT-23	DBV	5	3000	180.0	180.0	18.0
TL431CDBVR	SOT-23	DBV	5	3000	202.0	201.0	28.0
TL431CDBVT	SOT-23	DBV	5	250	202.0	201.0	28.0
TL431CDBVTG4	SOT-23	DBV	5	250	180.0	180.0	18.0
TL431CDBZR	SOT-23	DBZ	3	3000	202.0	201.0	28.0
TL431CDBZT	SOT-23	DBZ	3	250	202.0	201.0	28.0
TL431CDR	SOIC	D	8	2500	364.0	364.0	27.0
TL431CDR	SOIC	D	8	2500	340.5	338.1	20.6
TL431CDRG4	SOIC	D	8	2500	340.5	338.1	20.6
TL431CPK	SOT-89	PK	3	1000	340.0	340.0	38.0
TL431CPSR	SO	PS	8	2000	367.0	367.0	38.0
TL431IDBVR	SOT-23	DBV	5	3000	180.0	180.0	18.0
TL431IDBVR	SOT-23	DBV	5	3000	202.0	201.0	28.0
TL431IDBVRG4	SOT-23	DBV	5	3000	180.0	180.0	18.0
TL431IDBVT	SOT-23	DBV	5	250	180.0	180.0	18.0
TL431IDBZR	SOT-23	DBZ	3	3000	202.0	201.0	28.0
TL431IDBZT	SOT-23	DBZ	3	250	202.0	201.0	28.0
TL431IDR	SOIC	D	8	2500	364.0	364.0	27.0
TL431IDR	SOIC	D	8	2500	340.5	338.1	20.6
TL431IDRG4	SOIC	D	8	2500	340.5	338.1	20.6
TL431IPK	SOT-89	PK	3	1000	340.0	340.0	38.0
TL431QDBVR	SOT-23	DBV	5	3000	180.0	180.0	18.0
TL431QDBVT	SOT-23	DBV	5	250	180.0	180.0	18.0
TL431QDBZR	SOT-23	DBZ	3	3000	202.0	201.0	28.0
TL431QDBZT	SOT-23	DBZ	3	250	202.0	201.0	28.0
TL431QDCKR	SC70	DCK	6	3000	203.0	203.0	35.0
TL431QDCKT	SC70	DCK	6	250	203.0	203.0	35.0
TL431QDR	SOIC	D	8	2500	340.5	338.1	20.6
TL432ACDBVR	SOT-23	DBV	5	3000	180.0	180.0	18.0
TL432ACDBZR	SOT-23	DBZ	3	3000	202.0	201.0	28.0
TL432ACDBZT	SOT-23	DBZ	3	250	202.0	201.0	28.0
TL432AIDBVR	SOT-23	DBV	5	3000	180.0	180.0	18.0
TL432AIDBZR	SOT-23	DBZ	3	3000	180.0	180.0	18.0
TL432AIDBZR	SOT-23	DBZ	3	3000	202.0	201.0	28.0
TL432AIDBZT	SOT-23	DBZ	3	250	202.0	201.0	28.0
TL432AIDBZT	SOT-23	DBZ	3	250	180.0	180.0	18.0
TL432AIPK	SOT-89	PK	3	1000	340.0	340.0	38.0
TL432AQDBVR	SOT-23	DBV	5	3000	203.0	203.0	35.0
TL432AQDBVT	SOT-23	DBV	5	250	203.0	203.0	35.0
TL432AQDBZR	SOT-23	DBZ	3	3000	202.0	201.0	28.0
TL432AQDBZT	SOT-23	DBZ	3	250	202.0	201.0	28.0
TL432AQP	SOT-89	PK	3	1000	340.0	340.0	38.0
TL432BCDBVR	SOT-23	DBV	5	3000	203.0	203.0	35.0

Device	Package Type	Package Drawing	Pins	SPQ	Length (mm)	Width (mm)	Height (mm)
TL432BCDBZR	SOT-23	DBZ	3	3000	202.0	201.0	28.0
TL432BCDBZT	SOT-23	DBZ	3	250	202.0	201.0	28.0
TL432BCPK	SOT-89	PK	3	1000	340.0	340.0	38.0
TL432BIDBZR	SOT-23	DBZ	3	3000	202.0	201.0	28.0
TL432BIDBZR	SOT-23	DBZ	3	3000	180.0	180.0	18.0
TL432BIDBZT	SOT-23	DBZ	3	250	202.0	201.0	28.0
TL432BIDBZT	SOT-23	DBZ	3	250	180.0	180.0	18.0
TL432BIPK	SOT-89	PK	3	1000	340.0	340.0	38.0
TL432BQDBZR	SOT-23	DBZ	3	3000	180.0	180.0	18.0
TL432BQDBZR	SOT-23	DBZ	3	3000	202.0	201.0	28.0
TL432BQPK	SOT-89	PK	3	1000	340.0	340.0	38.0
TL432CDBVR	SOT-23	DBV	5	3000	180.0	180.0	18.0
TL432CDBZR	SOT-23	DBZ	3	3000	202.0	201.0	28.0
TL432CDBZT	SOT-23	DBZ	3	250	202.0	201.0	28.0
TL432CPK	SOT-89	PK	3	1000	340.0	340.0	38.0
TL432IDBVR	SOT-23	DBV	5	3000	203.0	203.0	35.0
TL432IDBVR	SOT-23	DBV	5	3000	180.0	180.0	18.0
TL432IDBZR	SOT-23	DBZ	3	3000	202.0	201.0	28.0
TL432IDBZT	SOT-23	DBZ	3	250	202.0	201.0	28.0
TL432IPK	SOT-89	PK	3	1000	340.0	340.0	38.0
TL432QDBZR	SOT-23	DBZ	3	3000	202.0	201.0	28.0
TL432QPK	SOT-89	PK	3	1000	340.0	340.0	38.0

JG (R-GDIP-T8)

CERAMIC DUAL-IN-LINE



- NOTES: A. All linear dimensions are in inches (millimeters).
 B. This drawing is subject to change without notice.
 C. This package can be hermetically sealed with a ceramic lid using glass frit.
 D. Index point is provided on cap for terminal identification.
 E. Falls within MIL STD 1835 GDIP1-T8

PK (R-PDSO-G3)



4208221/A 09/06

- NOTES:
- A. All linear dimensions are in millimeters.
 - B. This drawing is subject to change without notice.
 - C. Publication IPC-7351 is recommended for alternate designs.
 - D. Laser cutting apertures with trapezoidal walls and also rounding corners will offer better paste release. Customers should contact their board assembly site for stencil design recommendations. Refer to IPC-7525.
 - E. Customers should contact their board fabrication site for solder mask tolerances between and around signal pads.

P (R-PDIP-T8)

PLASTIC DUAL-IN-LINE PACKAGE



- NOTES:
- A. All linear dimensions are in inches (millimeters).
 - B. This drawing is subject to change without notice.
 - C. Falls within JEDEC MS-001 variation BA.

DBV (R-PDSO-G5)

PLASTIC SMALL-OUTLINE PACKAGE



- NOTES:
- A. All linear dimensions are in millimeters.
 - B. This drawing is subject to change without notice.
 - C. Body dimensions do not include mold flash or protrusion. Mold flash and protrusion shall not exceed 0.15 per side.
 - D. Falls within JEDEC MO-178 Variation AA.

DBV (R-PDSO-G5)

PLASTIC SMALL OUTLINE



- NOTES:
- A. All linear dimensions are in millimeters.
 - B. This drawing is subject to change without notice.
 - C. Customers should place a note on the circuit board fabrication drawing not to alter the center solder mask defined pad.
 - D. Publication IPC-7351 is recommended for alternate designs.
 - E. Laser cutting apertures with trapezoidal walls and also rounding corners will offer better paste release. Customers should contact their board assembly site for stencil design recommendations. Example stencil design based on a 50% volumetric metal load solder paste. Refer to IPC-7525 for other stencil recommendations.

DBZ (R-PDSO-G3)

PLASTIC SMALL-OUTLINE



- NOTES:
- A. All linear dimensions are in millimeters. Dimensioning and tolerancing per ASME Y14.5M-1994.
 - B. This drawing is subject to change without notice.
 - C. Lead dimensions are inclusive of plating.
 - D. Body dimensions are exclusive of mold flash and protrusion. Mold flash and protrusion not to exceed 0.25 per side.
 - Falls within JEDEC TO-236 variation AB, except minimum foot length.

DBZ (R-PDSO-G3)

PLASTIC SMALL OUTLINE

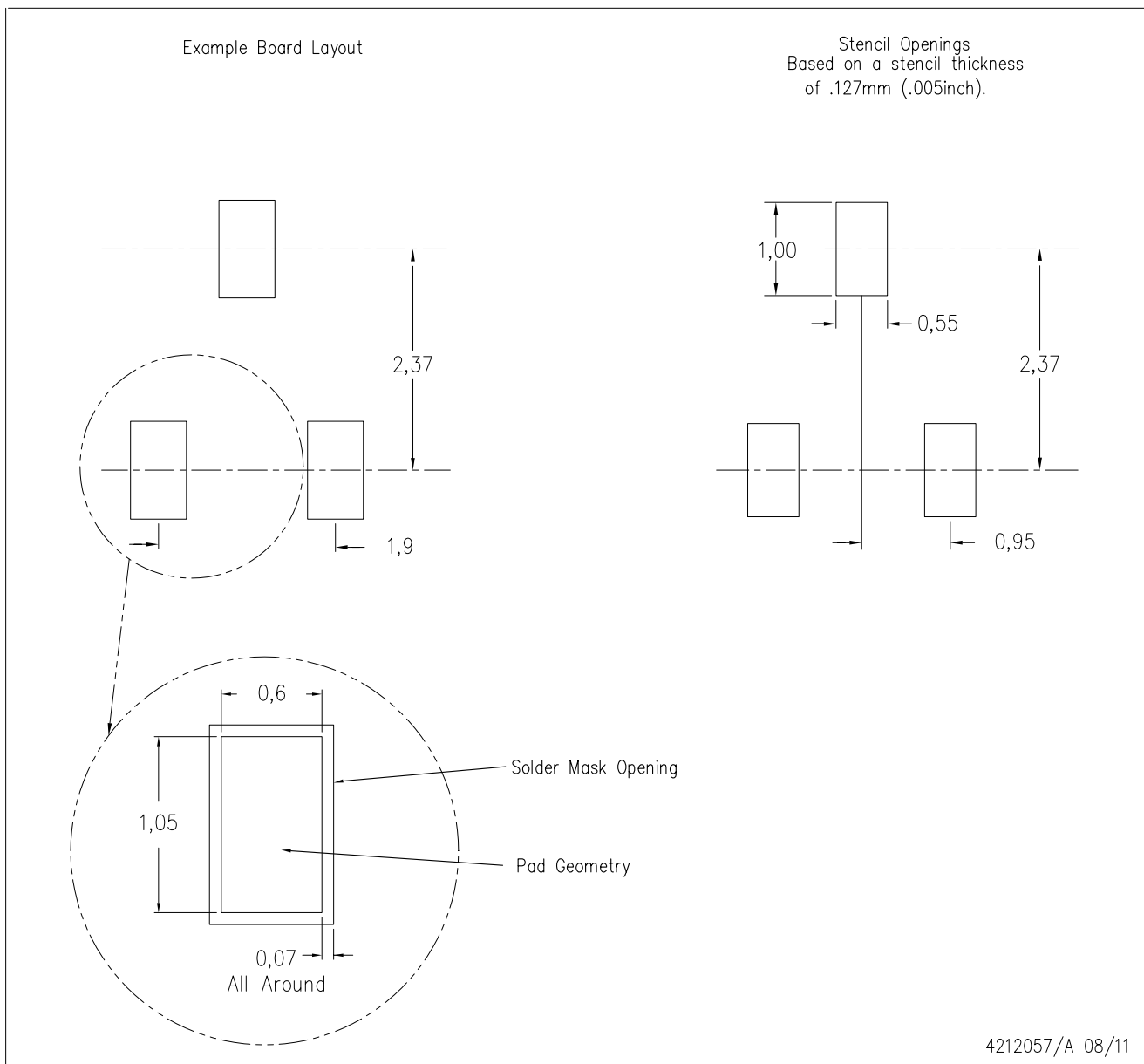

- NOTES:
- A. All linear dimensions are in millimeters.
 - B. This drawing is subject to change without notice.
 - C. Customers should place a note on the circuit board fabrication drawing not to alter the center solder mask defined pad.
 - D. Publication IPC-7351 is recommended for alternate designs.
 - E. Laser cutting apertures with trapezoidal walls and also rounding corners will offer better paste release. Customers should contact their board assembly site for stencil design recommendations. Example stencil design based on a 50% volumetric metal load solder paste. Refer to IPC-7525 for other stencil recommendations.

DCK (R-PDSO-G6)

PLASTIC SMALL-OUTLINE PACKAGE



- NOTES:
- A. All linear dimensions are in millimeters.
 - B. This drawing is subject to change without notice.
 - C. Body dimensions do not include mold flash or protrusion. Mold flash and protrusion shall not exceed 0.15 per side.
 - D. Falls within JEDEC MO-203 variation AB.

DCK (R-PDSO-G6)

PLASTIC SMALL OUTLINE



- NOTES:
- A. All linear dimensions are in millimeters.
 - B. This drawing is subject to change without notice.
 - C. Customers should place a note on the circuit board fabrication drawing not to alter the center solder mask defined pad.
 - D. Publication IPC-7351 is recommended for alternate designs.
 - E. Laser cutting apertures with trapezoidal walls and also rounding corners will offer better paste release. Customers should contact their board assembly site for stencil design recommendations. Example stencil design based on a 50% volumetric metal load solder paste. Refer to IPC-7525 for other stencil recommendations.

KTP (R-PSFM-G2)

PowerFLEX™ PLASTIC FLANGE-MOUNT PACKAGE

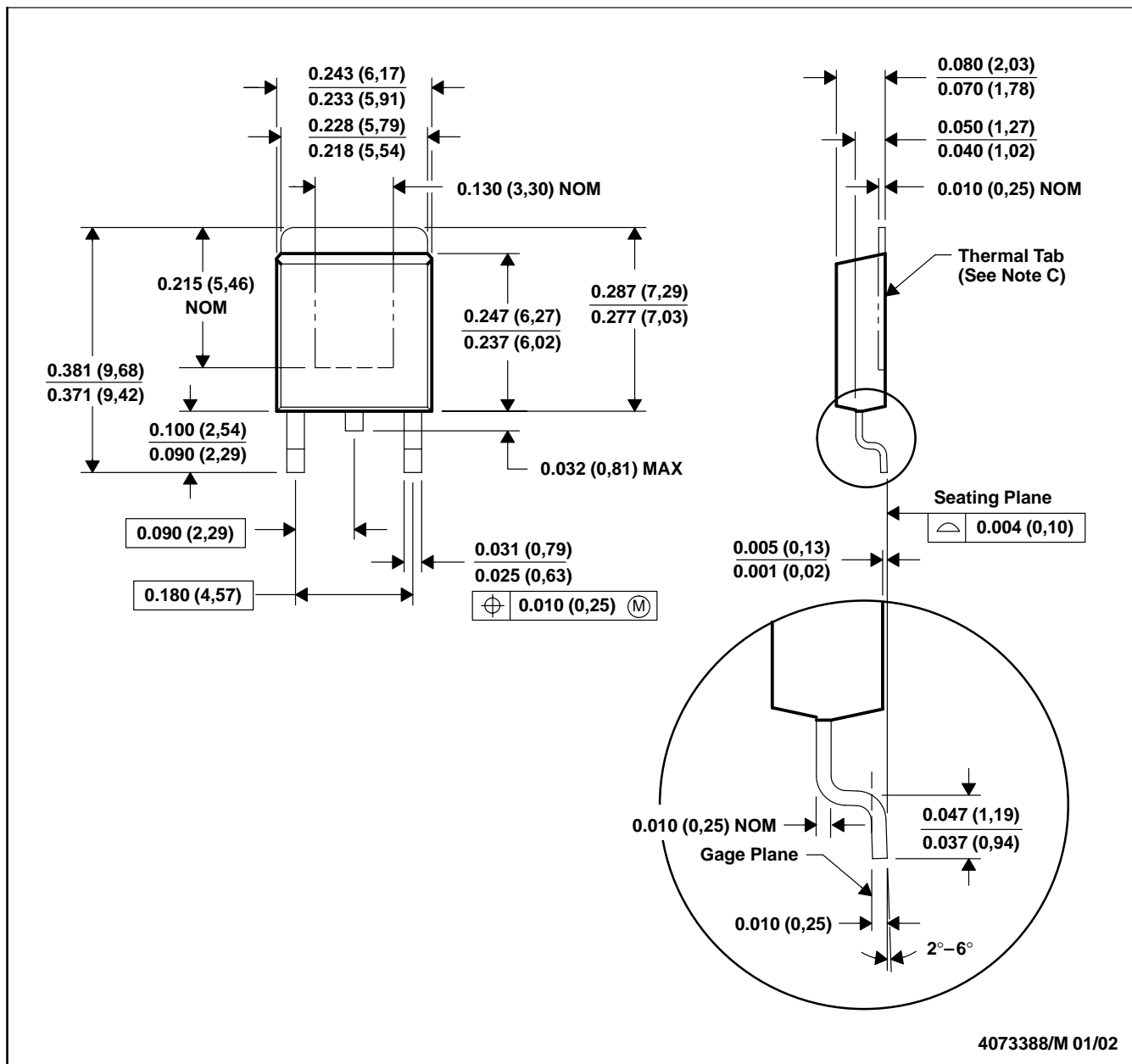

- NOTES: A. All linear dimensions are in inches (millimeters).
 B. This drawing is subject to change without notice.
 C. The center lead is in electrical contact with the thermal tab.
 D. Dimensions do not include mold protrusions, not to exceed 0.006 (0,15).
 E. Falls within JEDEC TO-252 variation AC.

PowerFLEX is a trademark of Texas Instruments.



D (R-PDSO-G8)

PLASTIC SMALL OUTLINE



- NOTES:
- A. All linear dimensions are in inches (millimeters).
 - B. This drawing is subject to change without notice.
 - C. Body length does not include mold flash, protrusions, or gate burrs. Mold flash, protrusions, or gate burrs shall not exceed 0.006 (0,15) each side.
 - D. Body width does not include interlead flash. Interlead flash shall not exceed 0.017 (0,43) each side.
 - E. Reference JEDEC MS-012 variation AA.

D (R-PDSO-G8)

PLASTIC SMALL OUTLINE



- NOTES:
- A. All linear dimensions are in millimeters.
 - B. This drawing is subject to change without notice.
 - C. Publication IPC-7351 is recommended for alternate designs.
 - D. Laser cutting apertures with trapezoidal walls and also rounding corners will offer better paste release. Customers should contact their board assembly site for stencil design recommendations. Refer to IPC-7525 for other stencil recommendations.
 - E. Customers should contact their board fabrication site for solder mask tolerances between and around signal pads.

MECHANICAL DATA

PS (R-PDSO-G8)

PLASTIC SMALL-OUTLINE PACKAGE



- NOTES:
- A. All linear dimensions are in millimeters.
 - B. This drawing is subject to change without notice.
 - C. Body dimensions do not include mold flash or protrusion, not to exceed 0,15.

PS (R-PDSO-G8)

PLASTIC SMALL OUTLINE



4212188/A 09/11

- NOTES:
- A. All linear dimensions are in millimeters.
 - B. This drawing is subject to change without notice.
 - C. Publication IPC-7351 is recommended for alternate designs.
 - D. Laser cutting apertures with trapezoidal walls and also rounding corners will offer better paste release. Customers should contact their board assembly site for stencil design recommendations. Refer to IPC-7525 for other stencil recommendations.
 - E. Customers should contact their board fabrication site for solder mask tolerances between and around signal pads.

LP (O-PBCY-W3)

PLASTIC CYLINDRICAL PACKAGE

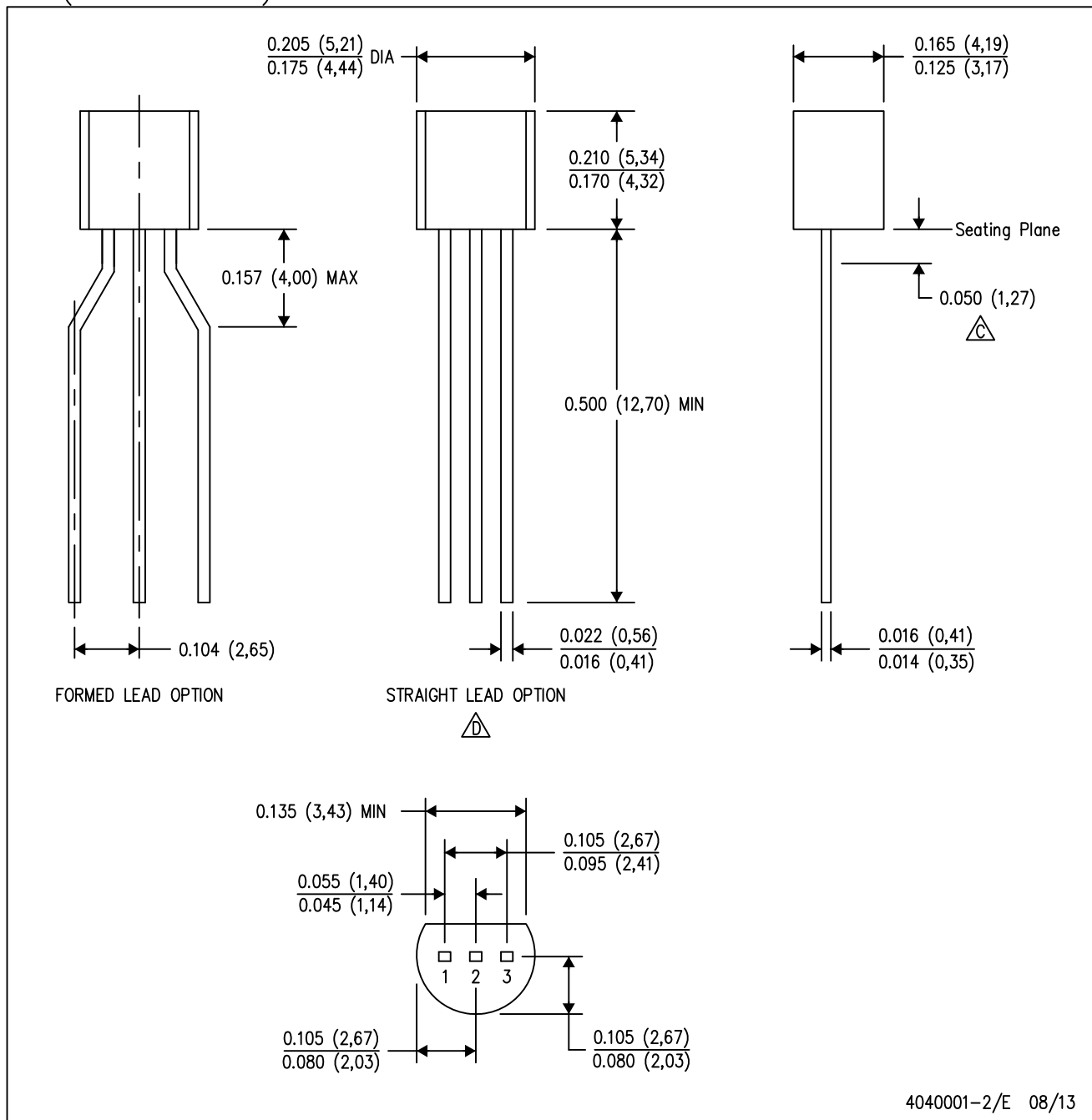

4040001-2/E 08/13

- NOTES:
- A. All linear dimensions are in inches (millimeters).
 - B. This drawing is subject to change without notice.
 - C. Lead dimensions are not controlled within this area.
 - D. Falls within JEDEC TO-226 Variation AA (TO-226 replaces TO-92).
 - E. Shipping Method:
 - Straight lead option available in bulk pack only.
 - Formed lead option available in tape & reel or ammo pack.
 - Specific products can be offered in limited combinations of shipping mediums and lead options.
 - Consult product folder for more information on available options.

MECHANICAL DATA

LP (O-PBCY-W3)

PLASTIC CYLINDRICAL PACKAGE

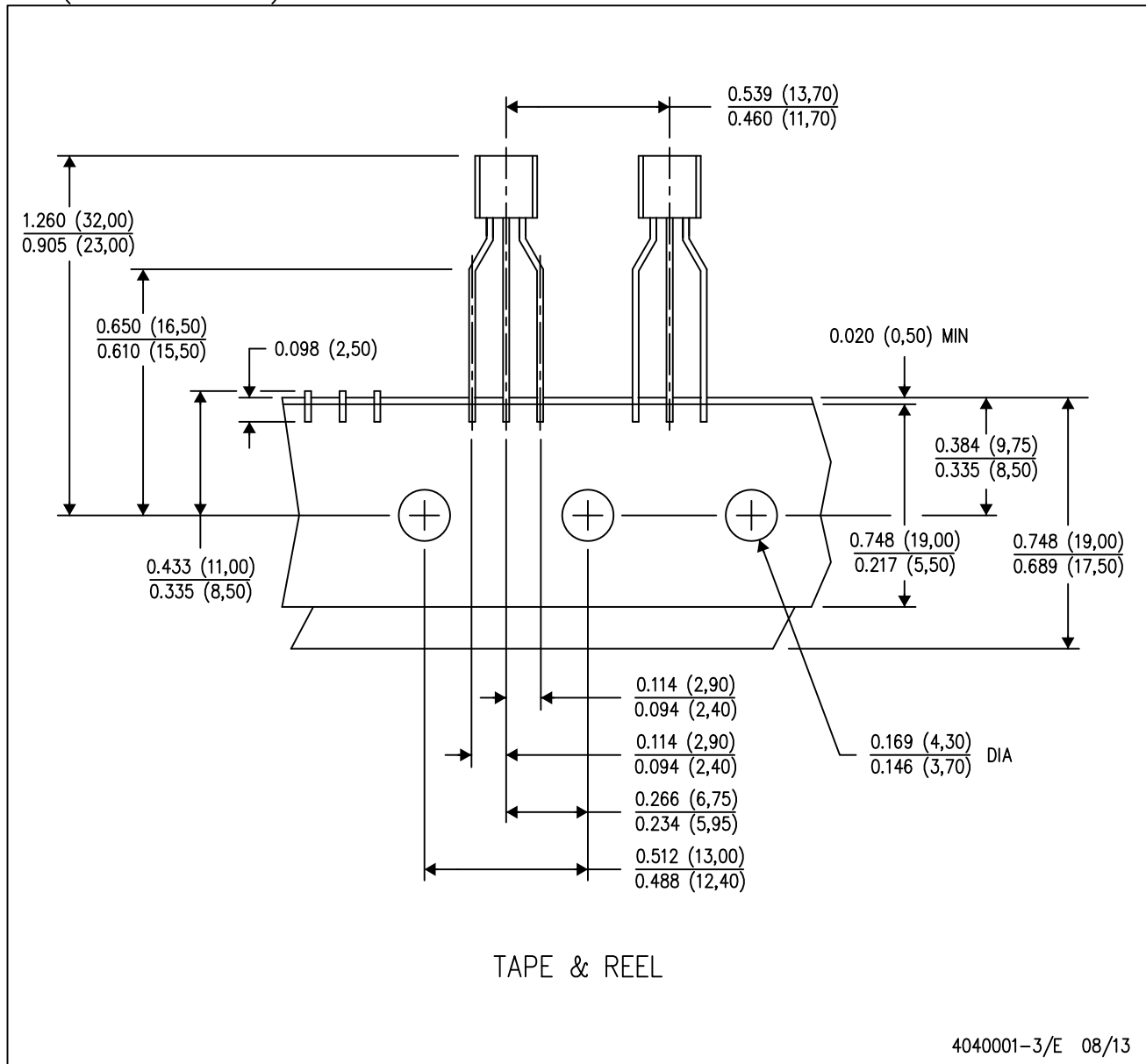

- NOTES:
- All linear dimensions are in inches (millimeters).
 - This drawing is subject to change without notice.
 - Tape and Reel information for the Formed Lead Option package.

PW (R-PDSO-G8)

PLASTIC SMALL OUTLINE

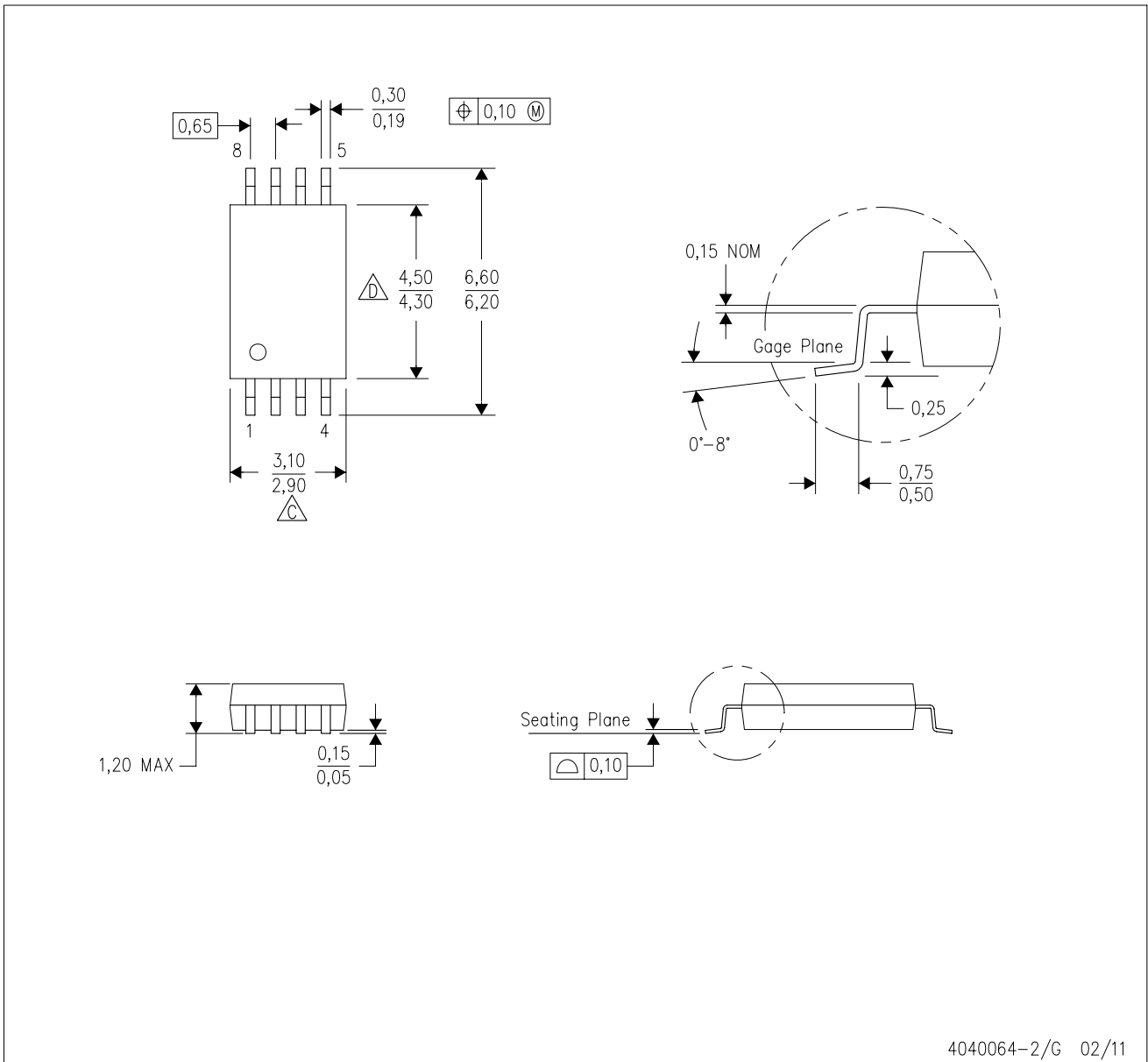

- NOTES:
- A. All linear dimensions are in millimeters. Dimensioning and tolerancing per ASME Y14.5M-1994.
 - B. This drawing is subject to change without notice.
 -  C. Body length does not include mold flash, protrusions, or gate burrs. Mold flash, protrusions, or gate burrs shall not exceed 0,15 each side.
 -  D. Body width does not include interlead flash. Interlead flash shall not exceed 0,25 each side.
 - E. Falls within JEDEC MO-153

IMPORTANT NOTICE

Texas Instruments Incorporated and its subsidiaries (TI) reserve the right to make corrections, enhancements, improvements and other changes to its semiconductor products and services per JESD46, latest issue, and to discontinue any product or service per JESD48, latest issue. Buyers should obtain the latest relevant information before placing orders and should verify that such information is current and complete. All semiconductor products (also referred to herein as "components") are sold subject to TI's terms and conditions of sale supplied at the time of order acknowledgment.

TI warrants performance of its components to the specifications applicable at the time of sale, in accordance with the warranty in TI's terms and conditions of sale of semiconductor products. Testing and other quality control techniques are used to the extent TI deems necessary to support this warranty. Except where mandated by applicable law, testing of all parameters of each component is not necessarily performed.

TI assumes no liability for applications assistance or the design of Buyers' products. Buyers are responsible for their products and applications using TI components. To minimize the risks associated with Buyers' products and applications, Buyers should provide adequate design and operating safeguards.

TI does not warrant or represent that any license, either express or implied, is granted under any patent right, copyright, mask work right, or other intellectual property right relating to any combination, machine, or process in which TI components or services are used. Information published by TI regarding third-party products or services does not constitute a license to use such products or services or a warranty or endorsement thereof. Use of such information may require a license from a third party under the patents or other intellectual property of the third party, or a license from TI under the patents or other intellectual property of TI.

Reproduction of significant portions of TI information in TI data books or data sheets is permissible only if reproduction is without alteration and is accompanied by all associated warranties, conditions, limitations, and notices. TI is not responsible or liable for such altered documentation. Information of third parties may be subject to additional restrictions.

Resale of TI components or services with statements different from or beyond the parameters stated by TI for that component or service voids all express and any implied warranties for the associated TI component or service and is an unfair and deceptive business practice. TI is not responsible or liable for any such statements.

Buyer acknowledges and agrees that it is solely responsible for compliance with all legal, regulatory and safety-related requirements concerning its products, and any use of TI components in its applications, notwithstanding any applications-related information or support that may be provided by TI. Buyer represents and agrees that it has all the necessary expertise to create and implement safeguards which anticipate dangerous consequences of failures, monitor failures and their consequences, lessen the likelihood of failures that might cause harm and take appropriate remedial actions. Buyer will fully indemnify TI and its representatives against any damages arising out of the use of any TI components in safety-critical applications.

In some cases, TI components may be promoted specifically to facilitate safety-related applications. With such components, TI's goal is to help enable customers to design and create their own end-product solutions that meet applicable functional safety standards and requirements. Nonetheless, such components are subject to these terms.

No TI components are authorized for use in FDA Class III (or similar life-critical medical equipment) unless authorized officers of the parties have executed a special agreement specifically governing such use.

Only those TI components which TI has specifically designated as military grade or "enhanced plastic" are designed and intended for use in military/aerospace applications or environments. Buyer acknowledges and agrees that any military or aerospace use of TI components which have **not** been so designated is solely at the Buyer's risk, and that Buyer is solely responsible for compliance with all legal and regulatory requirements in connection with such use.

TI has specifically designated certain components as meeting ISO/TS16949 requirements, mainly for automotive use. In any case of use of non-designated products, TI will not be responsible for any failure to meet ISO/TS16949.

Products

Audio	www.ti.com/audio
Amplifiers	amplifier.ti.com
Data Converters	dataconverter.ti.com
DLP® Products	www.dlp.com
DSP	dsp.ti.com
Clocks and Timers	www.ti.com/clocks
Interface	interface.ti.com
Logic	logic.ti.com
Power Mgmt	power.ti.com
Microcontrollers	microcontroller.ti.com
RFID	www.ti-rfid.com
OMAP Applications Processors	www.ti.com/omap
Wireless Connectivity	www.ti.com/wirelessconnectivity

Applications

Automotive and Transportation	www.ti.com/automotive
Communications and Telecom	www.ti.com/communications
Computers and Peripherals	www.ti.com/computers
Consumer Electronics	www.ti.com/consumer-apps
Energy and Lighting	www.ti.com/energy
Industrial	www.ti.com/industrial
Medical	www.ti.com/medical
Security	www.ti.com/security
Space, Avionics and Defense	www.ti.com/space-avionics-defense
Video and Imaging	www.ti.com/video

TI E2E Community

e2e.ti.com