

7 820 50/MSf 842-2c
 200 Hz (cycles)
 7 820 51/MSf 842-2c
 300 Hz (cycles)

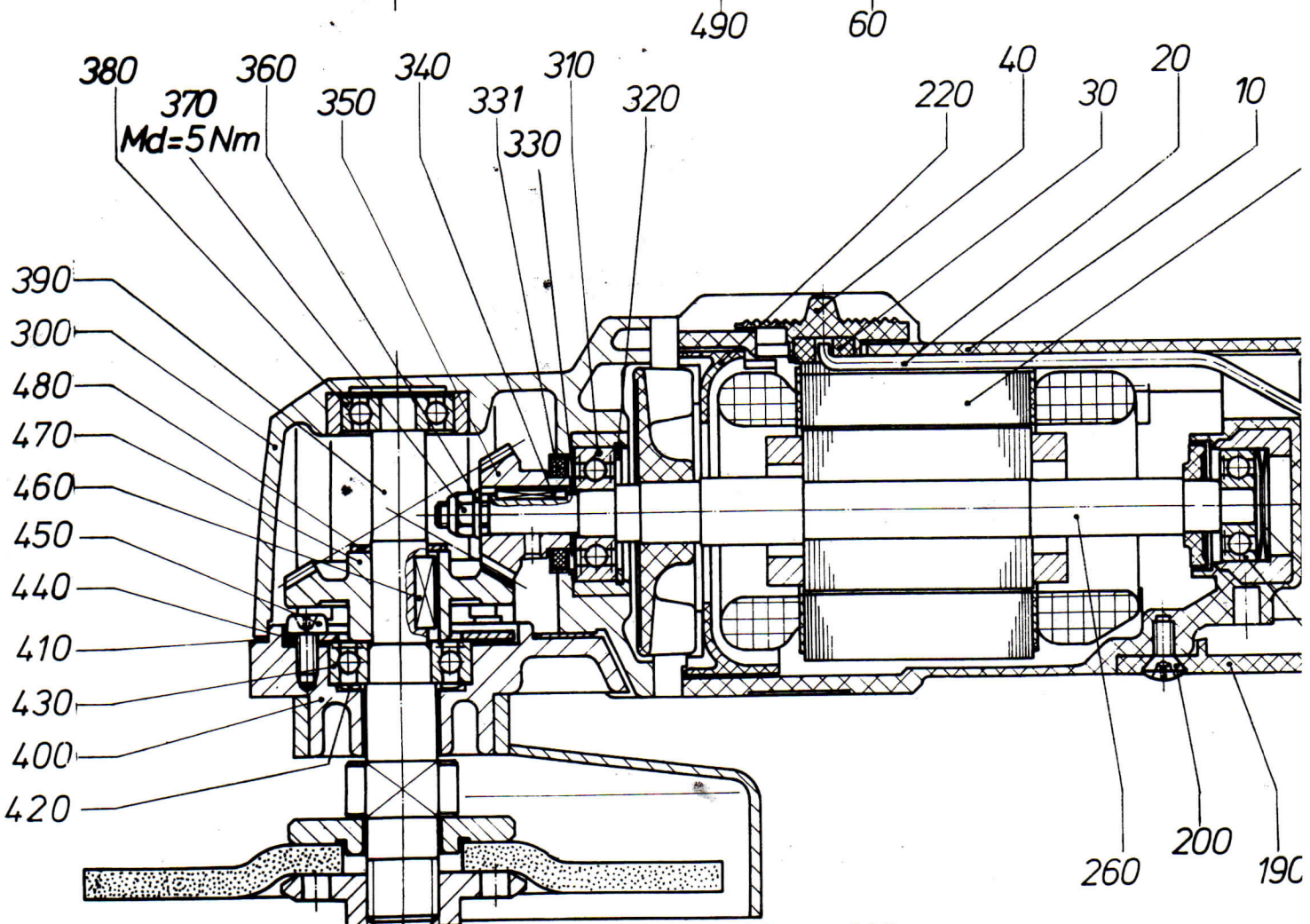

Nur für die Reparaturwerkstatt bestimmt!
 To be handed to the workshop!
 Pour l'atelier!

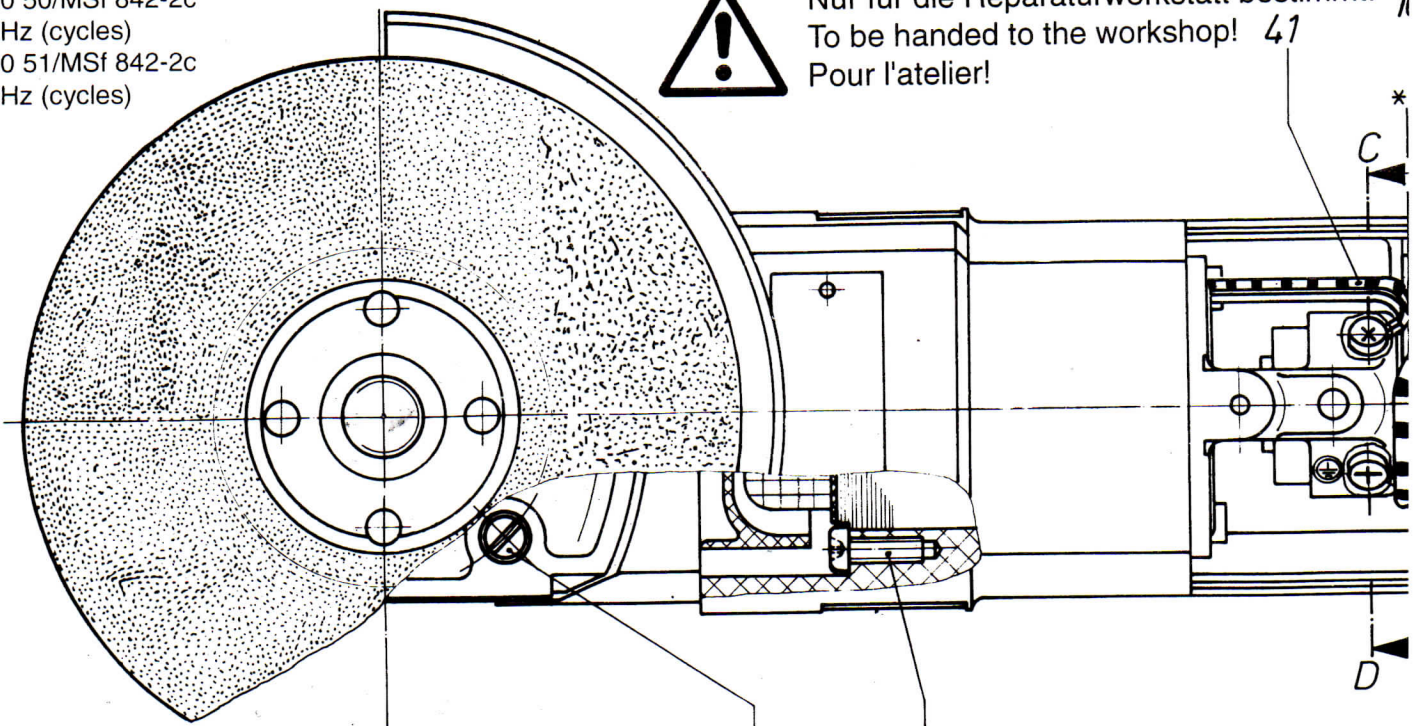

200 Hz Ausführung
 200 c/s Construction
 200 Hz Construction

Schaltschema
 Connecting plan
 Schéma des connexion

