

ONKYO. SERVICE MANUAL

QUARTZ SINGLE-PLAY FULLY AUTOMATIC TURNTABLE

Model CP-1030F

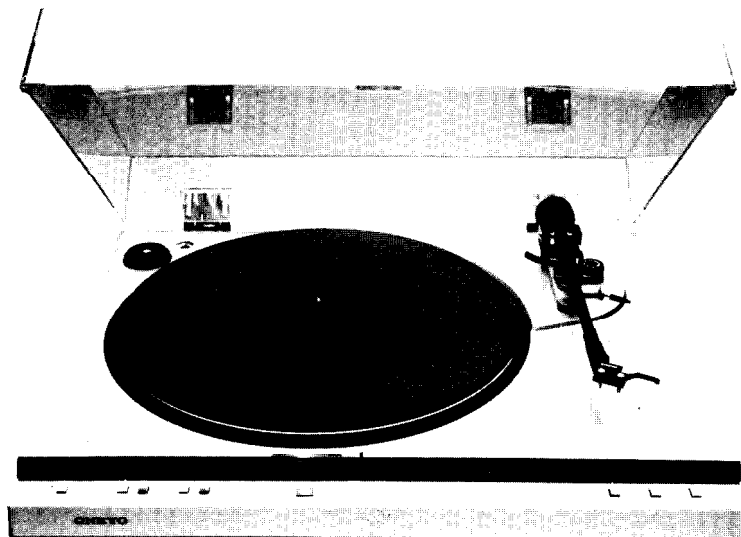

SPECIFICATIONS

Type:	2-speed fully-automatic turntable with cueing lever	Usable Cartridge Weight:	Min. 5.0 g, Max. 8.5 g
Turntable Platter:	31 cm (12-3/16") Aluminum diecast	Power Supply Rating:	AC 110-120, 220-240V, 50/60 Hz (or 240V 50Hz, 120V 60Hz, only)
Motor:	Brushless, coreless, slotless, DC Quartz Direct Drive	Power Consumption:	6 watts
Speeds:	33-1/3 rpm, 45 rpm	Dimensions (W x D x H):	453mm x 370mm x 133mm 17-7/8" x 14-1/2" x 5-1/4"
Wow & Flutter:	0.03% WRMS	Weight:	6.5 kg (14.3 lbs.)
Signal-to-Noise Ratio:	75 dB (DIN B)	Cabinet Composition	
Tonearm:	Static balanced straight pipe	Turntable Board:	Polystyrene
Effective Arm Length:	224mm (8-13/16")	Bottom Board:	Fiber Reinforced Polyethylene
Overhang:	13mm (1/2")	Dust Cover:	Polystyrene
Maximum Tracking Error:	+3 degrees, -1 degree		

In the interest of further product improvements specifications are subject to change without notice.

ONKYO
AUDIO COMPONENTS

BLOCK DIAGRAM

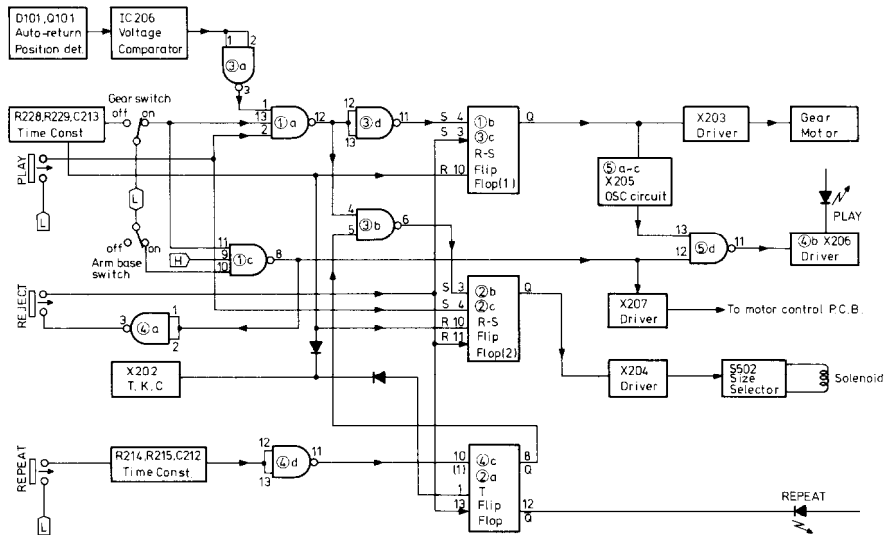

Notes: S: Set input of flip-flop
R: Reset input of flip-flop
Q, Q̄: Output of flip-flop
L: Low level (-12V)

Service Technology (Part 1)

- Note 1. Refer to the circuit diagram and block diagram.
2. "L" and "H" denote TTL positive logic, while the figures in circles denote IC pin terminal numbers and printed circuit board terminal numbers.
3. FF denotes flip-flop.

Play operation

- When IC1a (2) is dropped to "L" level, IC1a (12) is switched over to "H" and IC1b (6) is switched to "H" to turn X203 on, the main gear drive motor is started.
- When IC2b (4) is dropped to "L" level and IC2b (6) switched to "H" level to turn X204, the record size selector solenoid is activated.
- When the main gear drive motor is started, the main gear is rotated and SW7 gear switch is turned on.
- When the main gear switch is turned on, IC1c (11) is switched over to "L" and IC1c (8) is switched to "H" to turn X207 on, the turntable platter drive motor is started.
- When the main gear is rotated, the tonearm is operated and the tonearm switch is turned on.
- When the IC5a (1) input of oscillator circuit is switched "H" level, it's circuit is operated, thereby the play indicator repeat to turn on and off.
- When the rotation of main gear is finished, the gear switched restores R-F flip-flops to the initial condition and the play indicator is turned on.

Reject Operation

- When IC1b (3) is dropped to "L" level and IC1b (6) switched to "H" to turn X203 on, the main gear drive motor is again started up.
- When IC2c (10) is dropped to "L" level, IC2c (8) is switched to "H" and IC2b (6) to "L" to cut X204 off, thereby inhibiting the record size selector solenoid.

Repeat Operation

- When IC4c (10) is dropped to "L" level, IC4c (8) is switched to "H" and IC3b (5) kept at "H". When IC2a (1) is switched to "H" level, IC2a (12) is dropped to "L" to turn the repeat indicator L.E.D. on. When the tonearm returns automatically at the end of the record, IC206 (6) generates an H pulse (\square) which is then inverted by IC3d to become an L pulse. When this

pulse is applied to IC1a (1), resulting in IC1a (12) being switched to "H" level. Thereby when IC3b (6) switched "L" level, IC2b (6) switch to "H" to turn X204 on and activate the record size selector solenoid.

To release the repeat mode, simply press the REJECT key. In this case, IC2a(13) is dropped to "L" level, IC2a (12) switched to "H" and IC4c(8) to "L", followed by IC3b(5) being switched to "L" and IC3b(6) to "H". Then in conjunction with the reject operation described above, the repeat mode is released by reject action. In other words, the repeat mode is maintained only as long as IC3b(5) is kept at "H" level.

Restoration of Initial Condition

When the main gear drive motor is started up for play or reject operations, the main gear is also rotated. SW7 coupled to the main gear restores two R-S flip-flops initial condition.

Auto-Return

When an eccentric pin of the lead arm coupled to the tonearm is inserted between D601 and Q601, it serves as a shut-off mechanism which turns the Q601 phototransistor off. The difference in voltage is applied to a comparator via IC206 (3), resulting in the generation of a positive pulse which serves as the comparator output appearing at IC206 (6). This pulse is subjected to rectification and inversion at the CR and IC3a, thereby forming a negative pulse which is applied to IC1a(1). This is then followed by return or repeat operation in the same way as described above.

Manual Play

When the tonearm is raised from the arm reset by hand, the tone arm switch drops IC1c(10) to "L" level, resulting in IC1c(8) being switched to "H" to turn X207 on, thereby starting up the turntable motor by turn on of X207.

Stopping the Turntable Motor

- When the tonearm is returned manually to the arm rest IC1c(10) is switched instantaneously to "H" level and IC1c(8) to "L", thereby turning X207 off to bring the turntable motor to a stop.
- When the main gear starts to rotate during reject or auto-return mode, the SW7 gear switch is set to "on" position during rotation, and to "off" position end the end of one revolution. As soon as this single revolution is completed, IC1c(11) is switched to "H" level.

The arm switch is at "off" position (on the arm rest) at this time, and IC1c(10) is at "H" level. At the instant that IC1c(8) is switched to "L", resulting in X207 being cut off to stop the turntable motor.

Power On Reset

When the power switch is turned on, three FFs at X202 time constant circuit are reset to their prescribed initial state.

SERVICE PROCEDURES AND ADJUSTMENTS

1. Voltage Conversion

This turntable may be set to operate at either 110V – 120V or 220V – 240V at 50Hz to 60Hz. The voltage selector switch is under the turntable. If a voltage change is necessary, remove the lock plate, switch to the proper voltage, and replace the plate.

CAUTION: DISCONNECT POWER SUPPLY CORD FROM AC OUTLET BEFORE CONVERTING VOLTAGE.

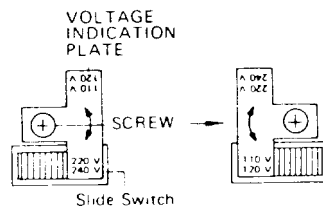

2. DD Motor Control Circuit Adjustment

1) Voltage adjustment

*Connect the DC voltmeter between 26 and ground terminals on the motor control p.c.b.

*Adjust VR304 to 12V reading.

2) Time base adjustment

*Connect the dual-image oscilloscope between terminal No. 14 and ground and terminal No. 16 and ground in the motor control p.c.b.

A=12.5msec. (33 rpm) (VR305) *12 msec*

A=10.0msec. (45 rpm) (VR306) *9 msec*

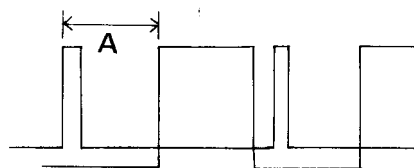

3. Wow and Flutter adjustment

Play the 3kHz test record, and adjust VR301 – VR303 so as reduce wow and flutter to a minimum.

4. Return Position Adjustment

Connect a DC voltmeter between pins 9 and 10 of the control circuit board, and adjust VR-201 so that the voltage lies within the $0.2 \pm 0.05V$ range.

Set the speed selector to 33 rpm, and reconnect the voltmeter to pins 9 and 11. Adjust VR-202 to obtain a reading of $0.8 \pm 0.05V$.

Then adjust the return position by the large eccentric pin attached to the tonearm base.

5. Lead-In Position Adjustment

The lead-in position is adjusted by means of the small eccentric pin attached to the base of the tonearm.

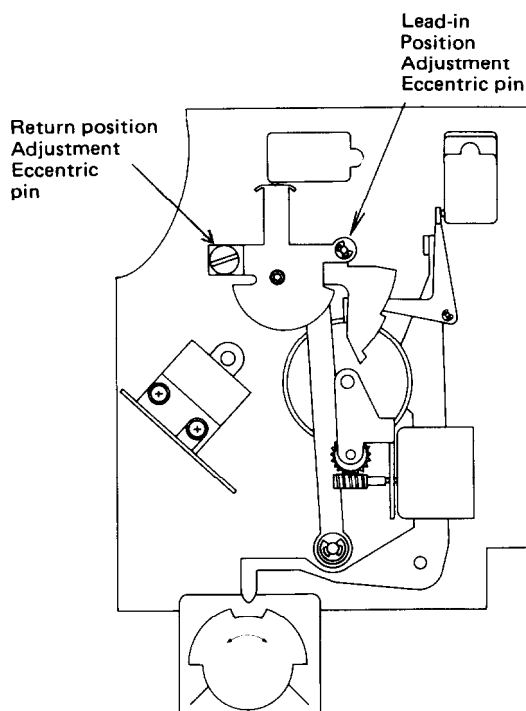

PACKING PROCEDURES

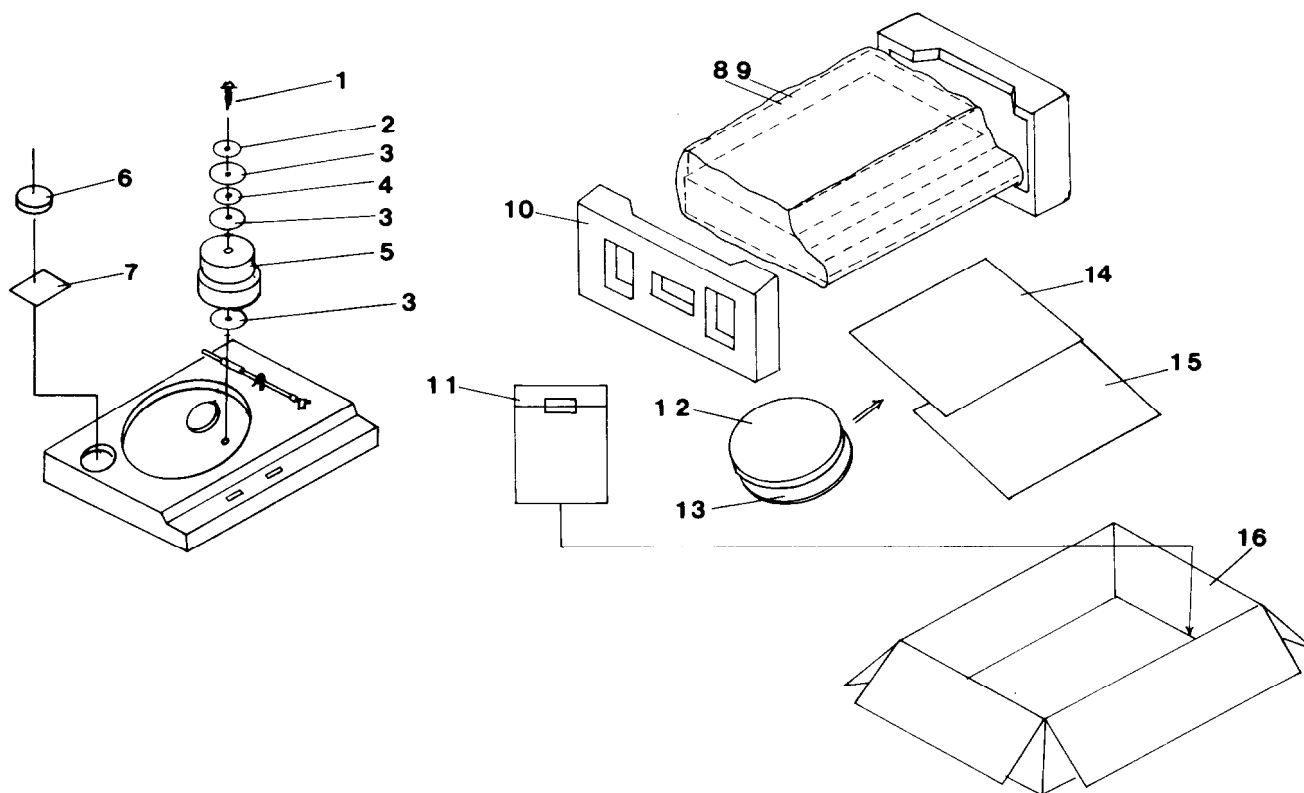

REF. NO.	PARTS NO.	DESCRIPTION
1	24059147	FMT±4 × 30, Screw
2	870063	FW4.6φ × 10φ × 0.5 ^t , Washer
3	24500464	Caution card
4	24506248	FW4.7φ × 28φ × 0.4 ^t , Washer
5	24501246	Counter weight
6	292049A	45 adaptor
7	24509061	Poly sheet
8	29095097	280 × 200 mm, Protection sheet (Power supply cord)
	29100042	550 × 550 mm, Protection sheet (Dust cover)
	29095012	800 × 500 mm, Protection sheet (Cabinet)
9	29100018	750 × 650 mm, Poly bag
10	24509139	Pad
11	29100005	220 × 330 mm, Poly bag
	29340369	Instruction manual (Universal and 240V model)
	29340370	Instruction manual (Only 120V model)
	25055018	CV-K-1, Conversion plug (Only Universal model)
	29365006	Warranty card (Only U.S.A. model)
	29365005-2	Warranty card (Only Germany model)
	24509168	Overhang gage
12	24502088	Turntable platter
13	24509085	T.T. mat
14	29100008	350 × 450 mm, Poly bag
15	24509162	500 × 420 mm, Bottom pad sheet
16	29050299	Carton box

REF. NO.	PARTS NO.	DESCRIPTION
1	24506255	Mechanism chassis
2	24506256	Selector ass'y
3	893032	E3, 2, Circlip
4	24503082	Spring for 2
5	24503081	Main gear (2)
6	24503080	Main gear (1)
7	24503083	Gear (1)
8	24505097	Switch p.c.b. complete
8-1	24506322	Switch p.c.b.
8-2	24504286	Seat for switch
8-3	25035163	NPS-111-S127, Switch
8-4	28320303	Push switch knob
8-5	24504285	Button sleeve
9	82113006	FM + 3 x 6, Pan head screw
10	24506259	Rotation plate
11	24506288	W5φ x 13φ x 1 ^t , Washer
12	24502079	Friction rubber
13	893040	E-4, Circlip
14	24506260	Switch arm
15	893020	E-2, Circlip
16		Play and Repeat indicator p.c.b. L.E.D. p.c.b. complete
17	24502080	Record size selector solenoid ass'y
17-1	24506261	Sub-chassis
17-2	24506289	Magnet ass'y
17-3	24506308	Selector cam ass'y
17-4	82112006	FM + 2 x 6, pan head screw
17-5	24506293	W3.1φ x 6φ x 0.1 ^t , Poly slider washer
17-6	24502081	Spool ass'y
17-7	893020	E-2, Circlip
17-8	82112604	FM + 2.6 x 4, Pan head screw
17-9		Damper
18	24503090	Switch ass'y
19	82112612	FM + 2.6 x 12, Pan head screw
20	24506280	Arm base ass'y
20-1	24506281	Arm base ass'y (1)
20-2	24506282	Eccentric pin
20-3	24506287	E-4, Circlip
20-4	24503089	Arm spring
20-5	841130140	M3 x 14, Hexagone bolt
20-6	24506283	Eccentric pin
21	24505099	Tonearm control p.c.b. complete
22	831130082	3STW + 8BQ, Tapping screw
23	24506313	Sensor holder ass'y
23-1	24503085	Sensor holder
23-2	24506268	Connector ass'y
23-3	260208	Binder
23-4	24506263	Sensor bracket
23-5	82113006	FM + 3 x 6, Pan head screw
24	24505101	Power supply p.c.b. (UU)
24-1	24505102	Power supply p.c.b. (UD)
24-2	24505068	Power supply cord (UU)
24-3	24505076	Power supply cord (UD)
25	24505098	L.E.D. p.c.b. complete
26	24506328	Switch bracket ass'y (1) (UU)
26-1	24506332	Switch bracket ass'y (1) (UD)
26-2	25035162	NPS-222-222-L126, Push switch
26-3		
26-4	25035149	NPS-121-L113P, Power switch (UU)
26-5	25035150	NPS-111-L114P, Power switch (UD)
26-6	24506327	Seat for switch
26-7	24506327	Switch bracket (2)
26-8	28320303	Push switch knob
27	83813006	BT + 3 x 6, Tapping screw
28	82113006	FM + 3 x 6, Pan head screw
29	24505112	Control p.c.b. complete
29-1	371121944	0.1μF, 50V, Mylar capacitor
29-2	24502087	Motor/control p.c.b. complete (UU)
29-3	24502086	Motor/control p.c.b. complete (UD)
30	831140124	FMT + 4 x 12, Screw
31	230341	NPT-689DQ, Power transformer (UU)
31	230342	NPT-689D, Power transformer (UD)
33		
34	24505079	Terminal ass'y (UU)
34-1	24505084	Terminal ass'y (UD)
34-2	24505061	Shielded wire (UU)
34-3	24505075	Shielded wire (UD)
35	24505012	3 x 14, Tube
36	24506151	Terminal
37	24506240	Tonearm ass'y
38	24504278	E-9, Circlip
39	24504279	FW10φ x 22φ x 1 ^t , Washer
40	893030	E3, Circlip
41	24504280	Elevation plate
42	24506276	Lifter arm
43	24506277A	Cueing lever
44	24506278	Lifter lever knob
45	24506279	Plate for cam
46	83313006	FMT + 3 x 6, Tapping screw
47	24506275	Special nut
48	24503088	Spring for cam
49	24504270	I.F.C. knob
50	24506243	Washer
51	24503077	I.F.C. spring
52	24504271	I.F.C. cam
53	831130062	3STW + 6BQ, Tapping screw
54	24501221	Arm rest
55	87113006	SSW3, Washer
56	861330	FLN3, Nut
57	833240124	FMT + 4 x 12, Tapping screw
58	24504263B	Lamp cover
59	833240164	FMT + 4 x 16, Tapping screw
60	24506304	Bracket, power supply (UU)
60	24506292	Bracket, power supply (UD)
61	290280	SR4K-4, Strainrelief (UU)
61	270025	SR-3P-4, Strainrelief (UD)
62	24509100	Leg (UU)
62	24509169	Leg (UD)
63	24509175	Leg (UU)
63	24509174	Leg (UD)
64	24506172	Receptacle for leg
65	24504277	Receptacle for leg
66	24509104	Mounting stud
67	24509157A	Bottom case
68	24509126	Dust cover ass'y
68-1	24504275	Name plate
68-2	24509127	Dust cover
68-3	24509128	Cushion
69	24506234	Hinge
70	24502088	Turntable platter
71	24509085	T.T mat
72	292049A	45 rpm adaptor
73	24509173	Cabinet ass'y
73-1	24504282	Operation plate
73-2	24509172	Cabinet
74	24503084	Gear (2)
75	24502084	DML-148Q-12, DC motor with 74

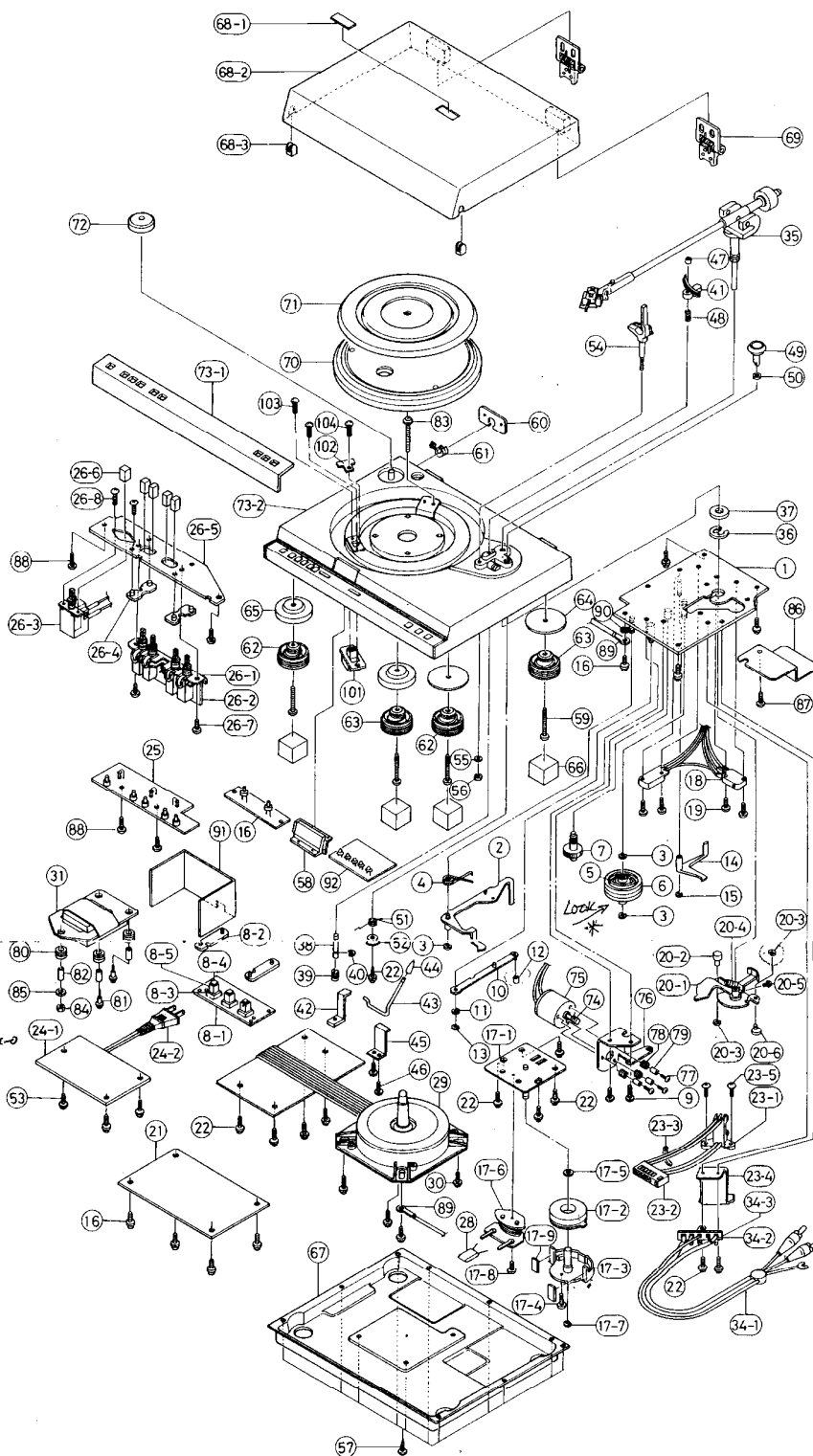

REF. NO.	PARTS NO.	DESCRIPTION
76	24506258	Bracket for gear
77	801212	FM + 2.6 x 6, Pan head screw
78	24610125	Rubber cushion
79	24610124	Collar for motor
80	24506331	Rubber cushion
81	24509179	Special screw
82	24506330	Sleeve
83	82233040	M3 x 40, Screw
84	86233010	WN3 x 10FN, Nut
85		
86	24506291	Shielded plate
87		
88	838130082	BT + 3 x 8, Tapping screw
89	24505081	Ground wire
90	87313008	TOW-3, Tooth washer
91	24506333	Shielded plate
92	24505096	Strobe Scope p.c.b. complete
93	28135061	Q mark badge
101	250159	Slide switch (UU)
102	24505065	Voltage plate (UU)
103	82113012	FM + 3 x 12, Pan head screw (UU)
104	838130082	BT + 3 x 8, Tapping screw (UU)
105	24509176	Rubber cap (UD)

NOTE: (UU) Only Universal model
(UD) Only U.S.A. model

CP-1030F
CP-1030F

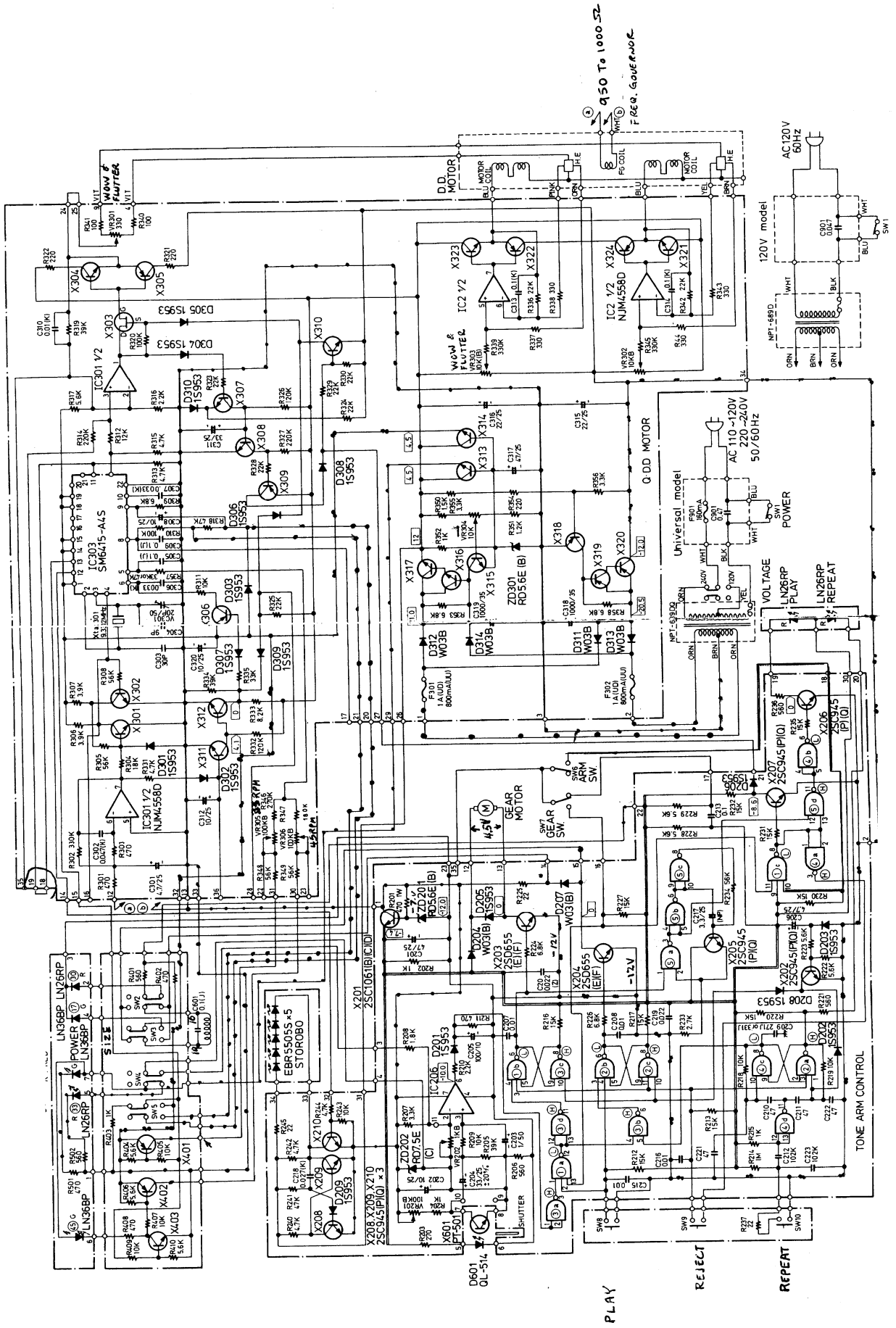

PARTS LIST

REF. NO.	CIRCUIT NO.	PARTS NO.	DESCRIPTION
8		24505097	Switch p.c.b.
16			Play and repeat indicator p.c.b.
21		24505099	Tonearm control p.c.b.
24		24505101	Power supply p.c.b. (UU)
		24505102	Power supply p.c.b. (UD)
25		24505098	Power/Speed/Size indicator p.c.b.
27		24505112	Control p.c.b.
29		24502087	Motor/control p.c.b. (UU)
		24502086	Motor/control p.c.b. (UD)
92		24505096	Strobo scope p.c.b.
	SW1	25035149	NPS-121-L113P, Power switch (UU)
	SW1	25035150	Power switch (UD)
	SW2-SW5	25035162	NPS-222-222-L126, Push switch
	SW6	24503049	K-3, Micro switch
	SW7	24503040	K-1, Micro switch
	SW8-SW10	25035163	NPS-111-S127, Tact switch
		225036	GL-514, L.E.D. for return detector
		226001	PT-501A, Phototransistor
35		24501250	Tonearm ass'y
		24501247	Screw for tonearm
		24501246	Counter weight
		24501252	Headshell
		24501231	Screw for cartridge
		24501232	Nut for cartridge
		24500079	Washer for cartridge
		24505106	2P+7P, Connector ass'y
		24505105	2P, brown and orange, Connector ass'y
		24505107	2P, yellow and green, Connector ass'y
		24505108	3P, Connector ass'y
		24505109	6P, Connector ass'y
		24505104	2P, red and blue, Connector ass'y

TONEARM CONTROL PC BOARD – PARTS LIST

CIRCUIT NO.	PARTS NO.	DESCRIPTION
	ICs	
IC201, IC202	222439 or 222481	SN7410N or HD7410P
IC203, IC204	222425 or 222478	SN7400N or HD7400P
IC205	222586 or 222582	SN74LS00 or HD74LS00
IC206	222545	μPC741C
	Transistors	
X201	2201082, 2201083 or 2201084	2SC1061(B), (C) or (D)
X202	2210353 or 2210354	2SC945(P) or (Q)
X203, X204	2211705 or 2211706	2SD655(E) or (F)
X205-X210	2210353 or 2210354	2SC945(P) or (Q)
	Diodes	
ZD201	223947 or 224091	RD5.6E or HZ6A-3L
ZD202	223954	RD7.5E(C)
D201-D203	223127	1S953
D204	223851	W03(B)
D205, D206	223127	1S953
D207	223851	W03(B)
D208, D209	223127	1S953
	Resistors	
R201	441624714	470Ω, 1W, Metal oxide film
VR201	5225015	N10HR10KBD, Semi-fixed
VR202	5225024	N10HR1KBD, Semi-fixed
	Capacitors	
C201	352754701	47μF, 25V, Elect.
C202	352741001	10μF, 16V, Elect.
C203	352780101	1μF, 50V, Elect.
C204	352743301	33μF±20%, 16V, Elect.
C205	352741011	100μF, 16V, Elect.
C206	352750471	4.7μF, 25V, Elect.
C217	352950336	3.3μF, 25V, Non-polar elect.
	Terminals	
Z4	24506302	2P
Z5	24506301	3P

	Connector posts	
Z7	24506318	2P
Z8	24506319	3P
Z9	24506299	4P
Z10	24506297	5P
Z11	24506320	6P

MOTOR/CONTROL PC BOARD – PARTS LIST

CIRCUIT NO.	PARTS NO.	DESCRIPTION
	ICs	
IC301, IC302	222465	NJM-4558D
IC303	222583	SM6415A-4S
	Transistors	
X301, X302	2210351 or 2211672	2SC945(K) or 2SC2308(B)
X303	2211292	2SK68(L)
X304	2210351 or 2211672	2SC945(K) or 2SC2308(B)
X305, X306	2211362 or 2210803	2SA844(B) or 2SA733(P)
X308, X307	2210351 or 2211672	2SC945(K) or 2SC2308(B)
X309	2211362 or 2210803	2SA844(B) or 2SA733(P)
X310-X316	2210351 or 2211627	2SC945(K) or 2SC2308(B)
X317	2200842	2SC1419(B)
X318, X319	2211362 or 2210803	2SA844(B) or 2SA733(P)
X320	2200852	2SA755(B)
X321, X323	2201112 or 2201122	2SD794(R) or 2SC1162(B)
X322, X324	2201132 or 2201142	2SB744(R) or 2SA715(B)
	Diodes	
ZD301	224082 or 223947	WZ056 or RD5.6EB
D301-D310	223127	1S953
D311-D314	223851	W03(B)
	X'tal	
Q301	3010039	9.3312MHz
	Semi-fixed resistors	
VR301	5225025	N10HR330BD
VR302-VR304	5225015	N10HR10KBD
VR305, VR306	5225080	N10HR100KBDM
	Capacitors	
C301	352750471	4.7μF, 25V, Elect.
C308	352751001	10μF, 25V, Elect.
C311	352753301	33μF, 25V, Elect.
C312	352751001	10μF, 25V, Elect.
C315, C316	352752201	22μF, 25V, Elect.
C317	352744701	47μF, 16V, Elect.
C318, C319	352761021	1,000μF, 35V, Elect.
C320	352751001	10μF, 25V, Elect.
VC301	3060008	NTC20P07, Trimmer
	Terminals	
Z4	24506302	2P
Z5	24506301	3P
Z6	24506300	4P
Z7	24506303	5P
	Fuseholder	
	24506098	(UD)
	24506312	(UU)
	Fuse	
F301, F302	252066	1A (UD)
	252080	800mA (UU)
	Fuse label	
	24505110	800mA (UU)
	2827281A	1A (UD)

SELECTOR PC BOARD – PARTS LIST

CIRCUIT NO.	PARTS NO.	DESCRIPTION
X401, X402	2210980	2SA641 (F), Transistor
X403	2210353	2SC945(P), Transistor
SW2-SW5	25035162	NPS-222-222-L126

**POWER, SPEED AND SIZE INDICATOR
L.E.D. PC BOARD-PARTS LIST**

CIRCUIT NO.	PARTS NO.	DESCRIPTION
	225038	LN26RP, L.E.D. for 33rpm and 30cm indicator
	225039	LN36BP, L.E.D. for power, 45rpm 17cm indicator
	24506349	7P connector post

PLAY AND REPEAT INDICATOR L.E.D. PC BOARD – PARTS LIST

CIRCUIT NO.	PARTS NO.	DESCRIPTION
	225038	LN26RP, L.E.D. for play and repeat indicator

STROBO SCOPE L.E.D. PC BOARD – PARTS LIST

CIRCUIT NO.	PARTS NO.	DESCRIPTION
	225037	EBR5505S, L.E.D. for strobo scope
	24505104	2P, Connector

SWITCH PC BOARD – PARTS LIST

CIRCUIT NO.	PARTS NO.	DESCRIPTION
	25035163	NPS-111-S127, switch

POWER SUPPLY PC BOARD – PARTS LIST (UU)

CIRCUIT NO.	PARTS NO.	DESCRIPTION
C901	24509154	4,700pF, AC 250V, CS capacitor
	24506311	Fuseholder
	252065	160mA, Fuse
	24505087	160mA, Fuse label

POWER SUPPLY PC BOARD – PARTS LIST (UD)

CIRCUIT NO.	PARTS NO.	DESCRIPTION
C901	24509155	0.047 μ F, AC125V, UL capacitor

NOTE: (UU): Only Universal model
(UD): Only 120V model

**Turntable “Flattens”
Warps**

Onkyo's new CP-1030F turntable is a single-play, fully automatic, direct-drive model with a quartz-lock speed control and a specially designed low-mass carbon-fiber

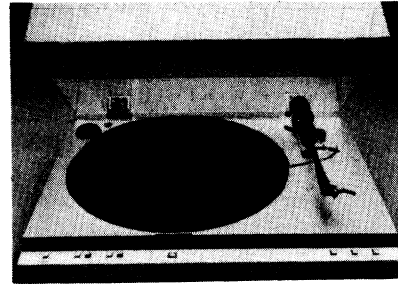

tonearm said to give optimum results with today's high-compliance cartridges. Low-frequency resonance of the arm and a typical high-compliance cartridge is controlled well enough, according to Onkyo, to allow warped records to be played with a minimum of distortion. In addition, the turntable has a rated signal-to-noise ratio of 75 dB and wow and flutter less than 0.03% (WRMS). Reliability of the unit is said to be enhanced by the use of an additional motor dedicated to tonearm functions. A set of LED indicators show what functions are engaged. \$315.

CIRCLE NO. 98 ON FREE INFORMATION CARD

Digital Encoder Interface

Sensor Technology has introduced an incremental encoder, the Digipot[®], which provides an interface manually with a digi-

POPULAR ELECTRONICS

ONKYO CORPORATION

International Division: No. 24 Mori Bldg., 23-5, 3-chome, Nishi-Shinbashi, Minato-ku, Tokyo, Japan
Telex: 2423551 ONKYO J. Phone: 03-432-6981

ONKYO U.S.A. CORPORATION

Eastern Office
42-07 20th Avenue, Long Island City, New York 11105, U.S.A. Phone: (212) 728-4639

Midwest Office
935 Sivert Drive, Wooddale, Illinois 60191, U.S.A. Phone: (312) 595-2970

ONKYO DEUTSCHLAND GMBH, ELECTRONICS

8034 München-Germering, Industriestrasse 18, West Germany. Telex: 521726 Telefon: (089)-84-5041