

tachometer

for mopeds and (motor) scooters

There are people who feel that every moped and motor scooter should be fitted with a tachometer (rev counter) as standard. There are others who find it a dodgy instrument since it tends to distract the rider's attention from the road. If you belong to the first category and have a scooter or moped without a rev counter, this article is for you. It describes a straightforward design of such an instrument that can be fitted to any model of moped or scooter.



Like many low-priced cars and motorcycles, mopeds and (motor) scooters tend not to have a rev counter fitted by the manufacturer, presumably on grounds of economy. However, such an instrument is relatively inexpensive and may be very useful, particularly on vehicles with manual gear change. For instance, the combined readings of the speedometer and tachometer give a good indication of whether the right gear has been selected. A falling reading on the rev counter is a sign to change down, while a rising one points to the need of changing up. Many riders who do not have the con-

venience of a rev counter argue that gear changing is done by ear, but the compulsory safety helmet does not always allow this: the sound insulation of some helmets is very good indeed! Best is, of course, to have an automatic gearbox, fortunately chosen by more and more riders. Second best is to build and fit the present tachometer.

The combined readings of speedometer and rev counter may also be useful in improving fuel consumption, but this implies that the power curve of the engine is known.

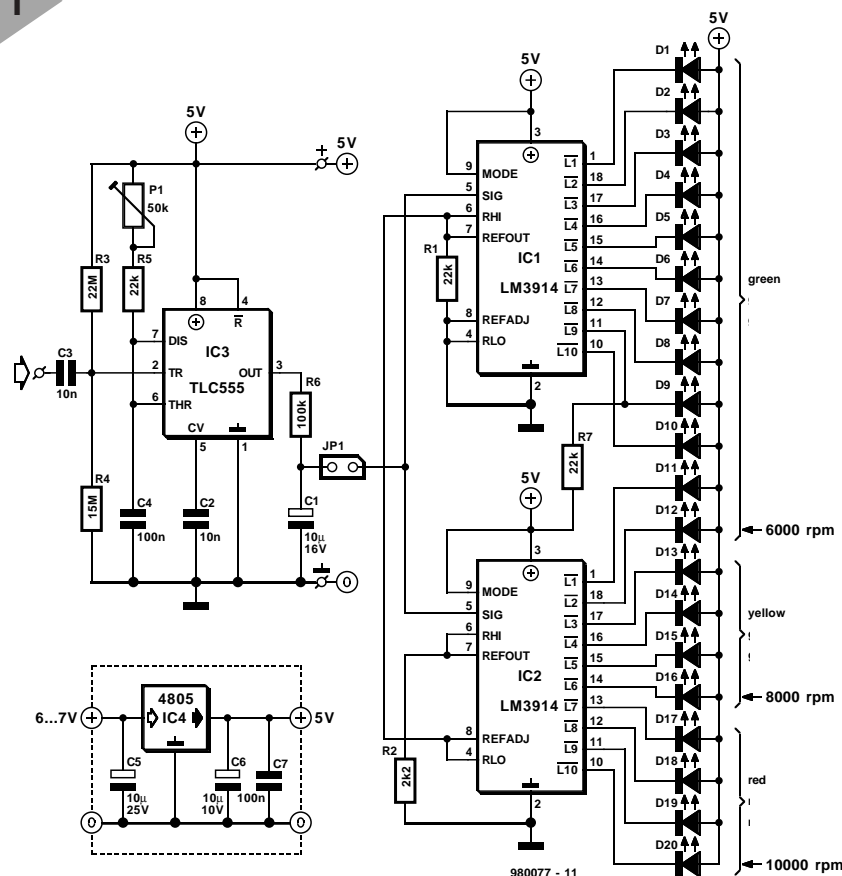

Figure 1. The circuit of the tachometer consists of a pulse shaper, an integrating circuit, and a readout. The sensor is placed around the spark plug cable.

DESIGN

There are various ways of constructing a tachometer, that is, the manner of its readout. Basically, there are three ways of achieving this: in figures via a seven-segment display, via an analogue scale consisting of light-emitting diodes (LEDs), or via a traditional moving coil meter with pointer.

The moving-coil type is the simplest construction, but is also vulnerable to shocks and vibrations. This makes it not really suitable for use on a moving vehicle.

A readout via a seven-segment display is highly accurate, but perhaps too sophisticated for use on a moped. The high accuracy is not needed and would make the design more complex than necessary.

An analogue (LED) readout is both simple and robust. It can make use of several types of control IC that enable an analogue voltage to be displayed on a bar of LEDs with only a few external components. If the bar consists of, say, 20 diodes, the readout is sufficiently accurate for most purposes.

The only other item that is needed is an electronic circuit with a sensor that provides pulses in proportion to the number of engine revolutions. These pulses are converted by the electronic circuit into an analogue direct voltage to drive the LED bar.

SENSOR

Ideally, the sensor should produce a pulse for each engine revolution and this is most easily achieved with the aid of an inductor (coil) to pick up the ignition pulses inductively. Since the voltage in the ignition pulses is fairly high, it suffices to construct the coil from 10–20 turns of insulated circuit wire around the spark-plug cable.

While the voltage level of the ignition pulses is fairly high, their shape varies appreciably. Therefore, the sensor is followed by a pulse shaper to transform the ignition pulses into stable, uniform count pulses. This ensures that random variations in the width and amplitude of the ignition pulses do not affect the readout.

CIRCUIT DESCRIPTION

The complete circuit diagram of the tachometer is shown in Figure 1. The pick-up coil (sensor) is linked to capacitor C₃. This capacitor, in conjunction with resistors R₃ and R₄, forms a differentiating circuit that narrows the ignition pulses into usable trigger pulses – an arrangement that prevents double triggering of the rev counter. The reshaped pulses are applied to the trigger input of monostable (multivibrator) IC₃. This circuit outputs pulses whose width can be preset with P₁.

The pulses output by IC₃ are integrated by a simple low-pass filter formed by R₆ and C₁. This filter also removes any short-duration variations of the output which otherwise might make the readout unstable.

The LED readout is driven by two display drivers, IC₁ and IC₂. These circuits are specially designed for this purpose and contain a reference voltage source and an accurate decade scaler.

Each of the drivers can control a maximum of ten LEDs, so that the tachometer can use up to 20 diodes which gives a sufficiently accurate readout. Each of the LEDs represents about 500 engine revolutions. The

Setting up

The pulse width of the output of the pulse shaper, and thus the drive voltage for the readout, can be set within a wide band with P1.

Calibrating the scale may be done in a number of ways: with another tachometer as reference, with a pulse generator, and also without any special equipment. This is possible by using the pick-up coil to sense the frequency of the mains voltage (in a safe manner!). This very stable signal at 50 Hz is excellent for calibration purposes, since it corresponds to 50×60=3000 rev/min. So, if the proposed maximum of 10000 rev/min is adopted, P1 should be adjusted at 50 Hz so that D6 (3000 rev/min) lights.

An ideal source for the 50 Hz mains frequency is a demagnetizer for a cassette deck. The electric field radiated by this is readily picked up by the tachometer sensor. Never, never connect the input of the rev counter directly to the mains: this may be lethal and, even if you're lucky to survive, will destroy the tachometer.

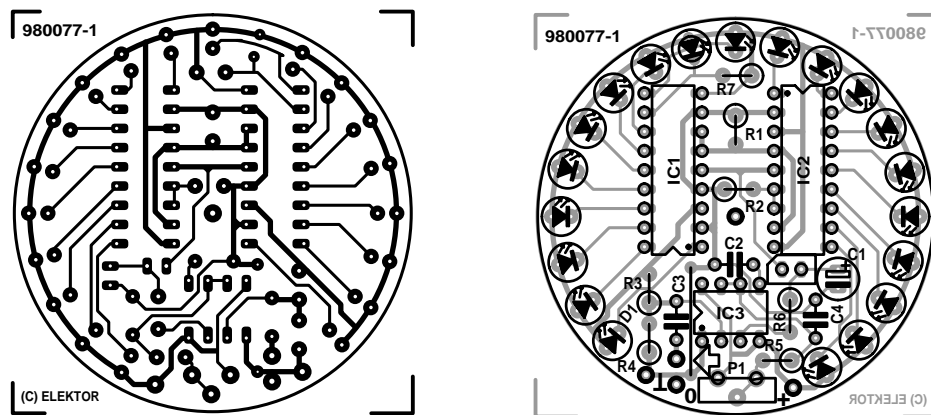

Figure 2. Construction of the tachometer is straightforward when this printed-circuit board is used. It is available through our Readers' services.

LEDs may be of different colours to create, say, a safe (green) range of revolutions of 500–6000 rev/min (D₁–D₁₂); a caution (yellow) range of 6000–8000 rev/min (D₁₃–D₁₆); and a danger (red) range above 8000 rev/min (D₁₇–D₂₀). Different ranges may, of course, be chosen to individual requirements.

Comparators are driven via each of the junctions of the scaler in the display drivers in such a way that every time the input voltage to the display driver increases the next comparator is enabled. The comparator outputs are capable of driving an LED directly.

The LED bar may be operated in the dot or bar mode. In the dot mode, pin 9 of the IC must be left open, and in the bar mode it should be linked to the positive supply rail. In the present application the bar mode is used.

means that the circuit cannot be connected directly to the battery terminals of the moped or scooter. A stable supply is obtained by the use of a 5 V regulator between the battery and the rev counter as shown in Figure 1. Since the voltage at the battery terminals is only about 6–7 V, the regulator must be a low-drop type such as the 4805: a standard 7805 will not do!

It is also possible to power the tachometer independently by a pack of

POWER SUPPLY

The tachometer needs a power supply of 5–6 V. The supply rails should be stable, which

Figure 3. The completed board in the Conrad enclosure mentioned in the text.

Parts list

Resistors:

R₁, R₅, R₇ = 22 kΩ
 R₂ = 2.2 kΩ
 R₃ = 22 MΩ
 R₄ = 15 MΩ
 R₆ = 100 kΩ
 P₁ = 47 kΩ (50 kΩ) preset

Capacitors:

C₁ = 10 μF, 16 V, radial
 C₂, C₃ = 0.01 μF, pitch 5 mm
 C₄ = 0.1 μF, pitch 5 mm

Semiconductors:

D₁–D₁₃ = low-current LED, green
 D₁₄–D₁₆ = low-current LED, yellow
 D₁₇–D₂₀ = low-current LED, red

Integrated circuits:

IC₁, IC₂ = LM3914
 IC₃ = TLC555

Miscellaneous:

JP₁ = 2-terminal 2.54 mm pin strip and pin jumper (Maplin)
 Enclosure: Conrad Type 842230-55 (see text)
 Sensor: see text
 PCB Order No. 980077 (see Readers' services towards the end of this issue).

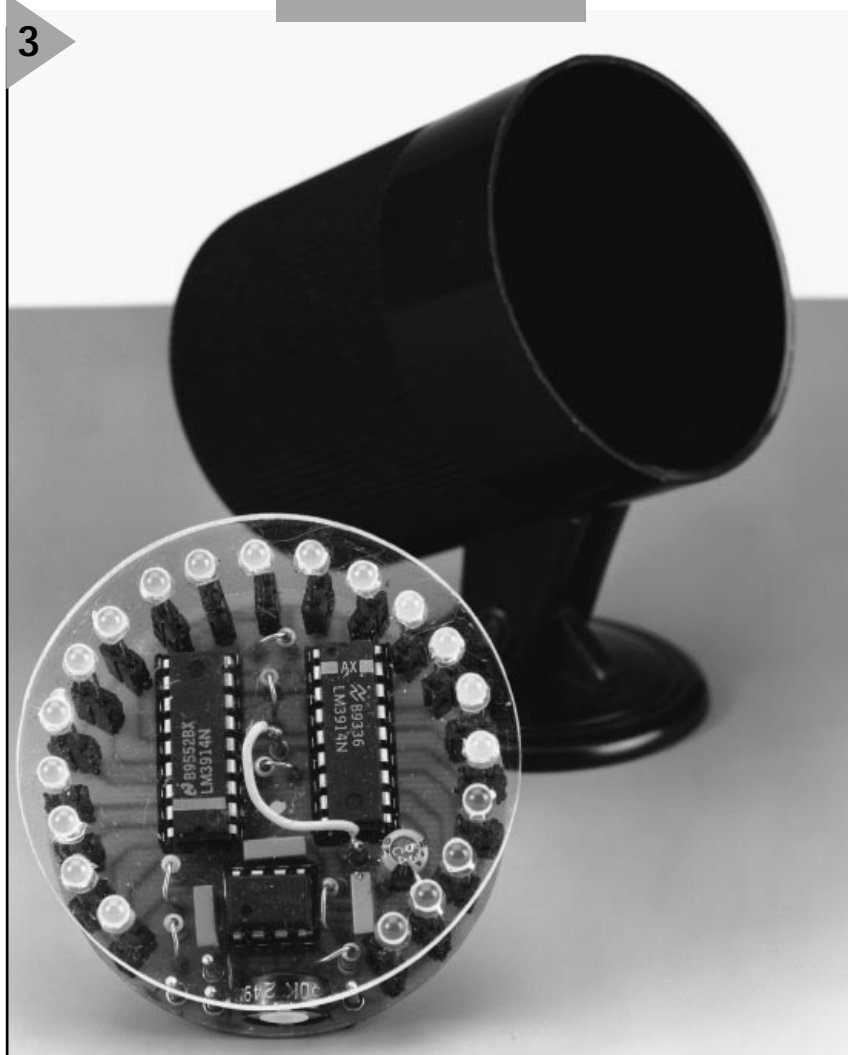

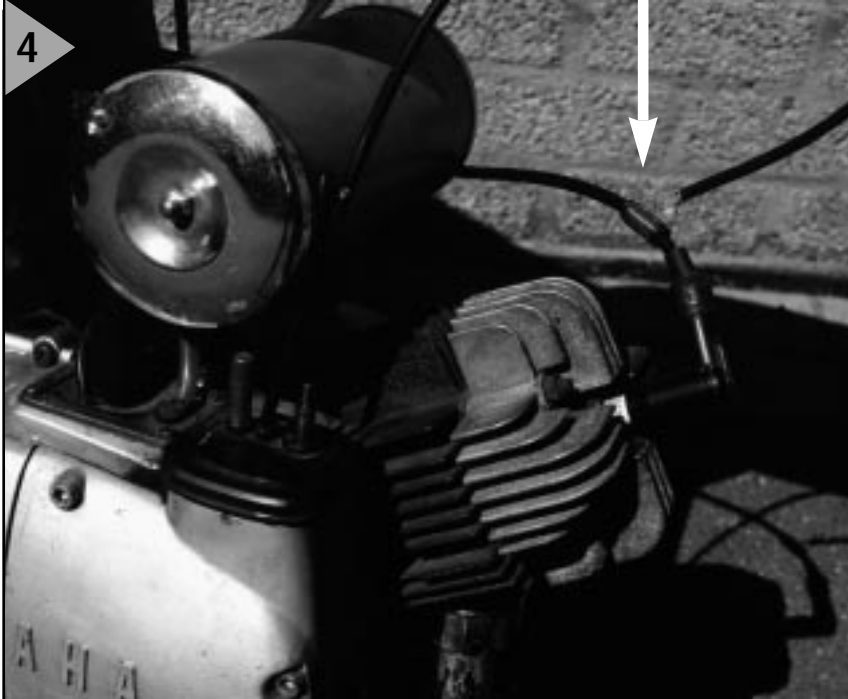

Figure 4. This photo clearly shows how the pick-up coil is wound (25 turns) around the ignition cable.

four series-connected chargeable or dry 1.5 V batteries (AA=HP7=LR6 or C=HP11=LR14). A regulator is then, of course, not needed. The life of such batteries is lengthened by using the display drivers in the dot mode (in which pin 9 of the devices is left open).

CONSTRUCTION

The electronics is best built on the printed-circuit board shown in Fig-

ure 2. It is generally agreed that a circular readout is to be preferred and this is why the 20 LEDs have been arranged in a circle on the board. In view of the sparsity of components, populating the board is simplicity itself if the circuit diagram and the parts list are followed carefully.

Pin strip and jumper JP₁ enables the circuit to be checked on completion of the construction. During such

a check, the jumper should be removed.

When pulses are applied to capacitor C₃, it should be possible to vary the low direct voltage at the terminal of JP₁ linked to junction R₆-C₁ with P₁. If this is so, the pulse shaper operates correctly.

When a variable direct voltage at a level of a few volts is applied to the other terminal of JP₁, one of the display diodes should light.

Forming the pick-up coil around the spark plug cable (10–20 turns of thin insulated circuit wire) should not present undue difficulties. The coil should be linked to the input pin of the tachometer via insulated stranded circuit wire.

In some areas it may be possible to obtain a round enclosure to house the rev counter. A suitable one is produced by Conrad (Germany) and may be available from our regular advertiser Stippler Elektronik via another regular advertiser, Viewcom Electronics. The model number of the enclosure is given in the parts list.

[980077]