

PEAVEY ELECTRONICS CORP.  
 711 A STREET  
 MERIDIAN, MISSISSIPPI 39301

TITLE  
 XXL POWER BOARD

SIZE  
 C

CODE  
 JCF

NUMBER  
 99099220

REV  
 A

DATE  
 6-DEC-2001

SHEET  
 1 OF 1

100 VRMS INTO 4, 8, OR 16 OHMS  
 (40 VRMS MAX)

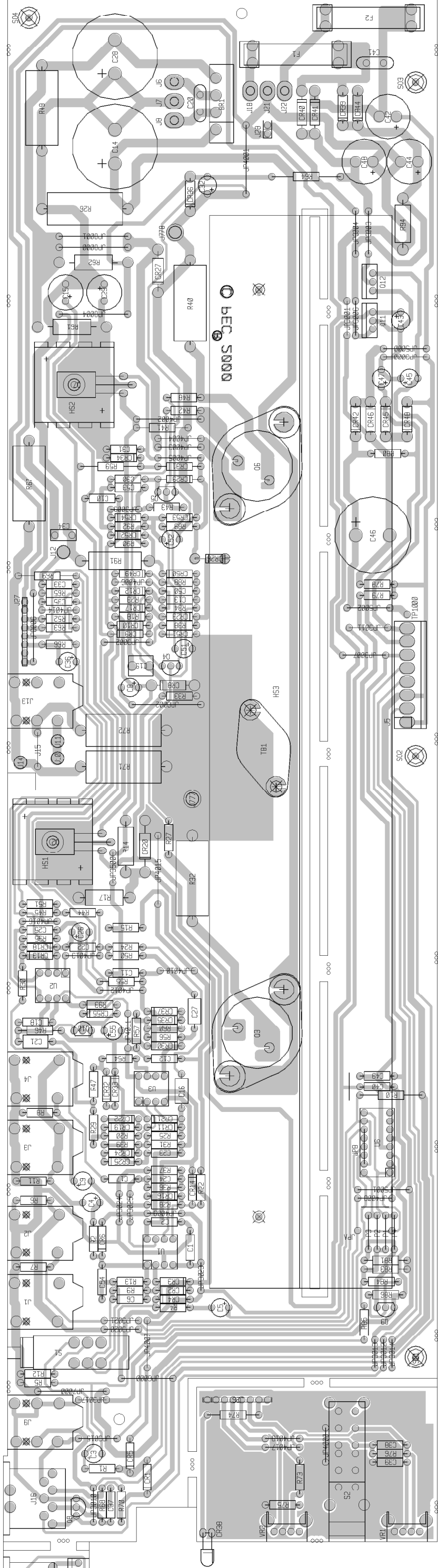

COMPONENTS NOT STUFFED IN ASSEMBLIES LISTED BELOW:

99053132 (REVOLUTION)	99099642 (WIGGY)	99099750 (TRANSTUBE 212)	99099220 (XXL)
CR38	C37	C37	C38
J9	CR33	C40	C39
J15	J13	C49	CR38
JPAC	J16	CR38	J9
JPBD	JP3010	J9	J13
P1	J28	J15	J26
P3	JPAC	J16	JPA
	JPBD	JP3010	JPB
	P2	P1	P1
	P4	P2	P3
	P20	P3	P20
	P21	P4	P21
	Q8	Q8	S2
	R68	Q9	VR1
	R70	R63	VR2
	R74	R70	
		F1	
		F2	
		R74	R73
		R81	R74
		R83	R75
		R84	R76
		R85	
		R86	
		U6	
		F1	

BILL OF MATERIALS REPORT

BOARD NAME: XXL PWR           REPORT DATE: 11DEC01  
 ASSEMBLY LEVEL NUMBER: 99099220  
 PROJECT NUMBER: P0100050  
 CBDS

PART           PART    DESCRIPTION AND  
 \*\* QTY. NAME   VALUE   NUMBER   DEVICE DESIGNATIONS \*\*\*\*\*  
 \*\*\*\*\*

1	98853132	98853132	98853132	PCB
2	.015	.015	70340010	.015MF----10%---50VDC---T/C---T&R C50, C53
2	.01CD	.01CD	70320248	.01MF----20%---1000VDC---CD--T&A C20, C41
12	.1	.1	70340100	.1MF----+80-20%--50VDC---AXL---T&R C1, C2, C11, C12, C13, C17, C23, C25, C30, C37, C40, C49
3	.1P10	.1P10	70340101	.1MF-----10%---50VDC---MON---T&R C16, C21, C27
1	.1SF	.1SF	70330113	0.10 MFD 10% 100V STCK FILM T&A C34
1	.22SF2	.22SF2	70330114	0.22 MF 5% 100V STCK FILM t&a C19
4	.33W5	.33W5	70250003	.33--5W--10%--WW--AXL R32, R40, R71, R72
1	1.43KP1	1.43KP1	70241039	1.43K-1/4W--1%---MF--T&R R51
3	1.5K	1.5K	70240018	1.5K--1/4W--5%---CF--T&R R12, R18, R59
1	1.5KW1	1.5KW1	70210007	1.5K--1W---5%---MO--T&R R94
1	10	10	70240003	10---1/4W--5%---CF--T&R R85
2	100	100	70240010	100---1/4W--5%---CF--T&R R34, R43
3	1000R35	1000R35	70320186	1000MF----20%---35VDC--EL--T&A C42, C44, C48
1	1000SV50	1000SV50	70320147	1000MF--30/20%--50VDC--EL-R/S

C46

3	100FP	100FP	70240096	100FP-1/4W--5%---FP--T&R
				R33, R38, R41
8	100K	100K	70240034	100K--1/4W--5%---CF--T&R
				R25, R29, R31, R46, R47, R56, R57, R65
5	100PF	100PF	70340054	100PF-----10%-----50VDC----T/C----T&R
				C6, C10, C22, C24, C31
3	10K	10K	70240025	10K---1/4W--5%---CF--T&R
				R63, R81, R83
1	10PF	10PF	70340050	10PF-----5%-----T/C----T&R
				C18
1	13886	13886	70413886	SZ-13886-2 DUAL DIODE
				CR26
2	15K	15K	70240027	15K---1/4W--5%---CF--T&R
				R66, R68
1	180	180	70240012	180---1/4W--5%---CF--T&R
				R42
1	180PF	180PF	70340056	180PF-----10%-----50VDC----T/C----T&R
				C54
2	1ASB	1ASB	70900379	1 AMP S/B FUSE WITH 2 FUSECLIPS #70900816
				F1, F2
3	1K	1K	70240017	1K---1/4W--5%---CF--T&R
				R2, R15, R64
2	1M	1M	70240039	1M---1/4W--5%---CF--T&R
				R6, R7
6	1N4003	1N4003	70464003	1N4003 200V SILICON DIODE
				CR39, CR40, CR41, CR42, CR44, CR46
34	1N4148	4148	70464148	1N4148 75V 10MA SILICON DIODE
				CR1, CR2, CR3, CR4, CR5, CR6, CR10, CR11, CR12, CR13, CR14, CR16, CR17, CR18, CR19, CR21, CR22, CR23, CR24, CR25, CR29, CR30, CR31, CR32, CR33, CR35, CR37, CR49, CR50, CR51, CR52, CR53, CR54, CR55
4	1N4744	4744	70440102	SZG40102 15V 5% ZENER DIODE
				CR8, CR36, CR45, CR48
2	1N5393	5393	70465393	1N5393-RL 200V, 1.5, 5% DIODE -T&R
				CR20, CR27

2 1SS142 1SS142 70400142 1ss142 250v SILICON DIODE  
CR9, CR34

1 2.2K 2.2K 70240020 2.2K--1/4W--5%----CF--T&R  
R55

6 2.2R50 2.2R50 70320180 2.2MF-----20%----50VDC---EL--T&A  
C3, C4, C5, C9, C36, C55

1 2.7K 2.7K 70240021 2.7K--1/4W--5%----CF--T&R  
R80

2 2.7KW1 2.7KW1 70210016 2.7K--1W----5%----MO--T&R  
R14, R62

2 2200R63 2200R63 70320347 2200MF---20%---63VDC---EL---R/S  
C14, C28

2 220K 220K 70240036 220K--1/4W--5%----CF--T&R  
R8, R84

2 220R63 220R63 70320305 220uF---63V--20%---EL--T&A  
C15, C29

1 22FP 22FP 70240100 22FP--1/4W--5%----FP-----  
R70

8 22K 22K 70240029 22K---1/4W--5%----CF--T&R  
R4, R5, R11, R22, R28, R36, R37, R52

8 22R50 22R50 70320181 22MF-----20%----50VDC---EL--T&A  
C8, C26, C32, C43, C45, C47, C51, C52

2 22W1 22W1 70210001 22----1W----5%----MO--T&R  
R17, R61

2 2KW5 2KW5 70250063 2K--5W--10%--WW--AXL  
R26, R49

2 2N3904 3904 70463904 3904/SPS7239 TO 92 NPN T&A  
Q8, Q9

1 3.3K 3.3K 70240022 3.3K--1/4W--5%----CF--T&R  
R1

1 33 33 70240004 33----1/4W--5%----CF--T&R  
R23

1 33K 33K 70240030 33K---1/4W--5%----CF--T&R  
R13

2 39PF 39PF 70340052 39PF-----50VDC----T/C----T&R

C33, C35

8 4.7K 4.7K 70240023 4.7K--1/4W--5%----CF--T&R  
R20, R30, R44, R45, R54, R69, R89, R90

4 437STW 70901891 70901891 SPCR, .437(#4),.187 SW,AL.  
SO1, SO2, SO3, SO4

3 4560 4560 70414560 4560 DUAL OP AMP IC  
U1, U2, U3

2 470 470 70240015 470---1/4W--5%----CF--T&R  
  
R88, R92

2 470K 470K 70240038 470K--1/4W--5%----CF--T&R  
R10, R93

2 47FP 47FP 70240090 47FP--1/4W--5%----FP--T&R  
R78, R79

6 47K 47K 70240031 47K---1/4W--5%----CF--T&R  
R24, R35, R39, R50, R60, R86

1 5.6W5 5.6W5 70250026 5.6--5W--10%--WW--AXL  
R67

1 5331 5331 70405331 SJE-5331 CASE-77 NPN  
Q2

1 6.8KW2 6.8KW2 70250052 6.8K---2W---5%---MF---T&R  
R91

1 6531 6531 70466531 MPS-6531 TO92 NPN TRANS. T&A  
Q4

1 6533 6534 70466533 MPS-6533/34 TO-92 PNP TRANS T&A  
Q5

1 68K 68K 70240032 68K---1/4W--5%----CF--T&R  
R9

1 7036 7036 70407036 SJE-7036 CASE-77 PNP XSISTOR  
Q7

1 73100AT 73100T 70473100 SJ-73100, 3 AMP, 100V, METRIC TO-3, PNP TRANS  
Q6

1 7815FVRT 7815FVER 70400318 7815 15V 1A POS TO-220 RG VERT MNT INS  
Q11

1 7915FVRT 7915FVER 70400319 7915 15V 1A NEG TO 220 RG VERT MNT INS

Q12

2 820 820 70240019 820---1/4W--5%----CF--T&R

R27, R48

1 83100AT 83100T 70483100 SJ-83100, NPN, 3 AMP, 100V, METRIC TO-3 TRANS

Q3

1 CAB0183 70600183 70600183 8C--10"--IDC CABLE ASSM.--.100 CTRS

J27

1 CAB0184 CAB0184 70600184 2C 8" SPOX RIBBON CABLE .100 CTR

J28

1 DG211 DG211 70420211 DG211 C.J.I.C.

U6

1 DIN7RA 71466226 71466226 CONN 7P R/A PCMNT DIN W/ 4 MNT. HOLES

J16

3 FMPU 73711811 73711811 M118-171 C.B. FEMALE MOLEX PIN

J7, J18, J22

1 HS0675 98000675 98000675 TKO 80 HEATSINK

HS3

2 HS2522 98002522 98002522 3/8" HEATSINK PUNCHED

HS1, HS2

1 J174 J174 70460174 I-174 30V TO-92 P-CHAN FET T&A

Q10

20 J325 J 70600005 22GA JUMPER WIRES T&R

JP3000, JP3001, JP3002, JP3003, JP3004,  
JP3006, JP3007, JP3009, JP3010, JP3011,  
JP3012, JP3013, JP3014, JP3015, JP3017,  
JP3020, JP3021, JP3023, JP3024, JP3025

1 J35 J 70600005 22GA JUMPER WIRES T&R

JP3500

16 J4 J 70600005 22GA JUMPER WIRES T&R

JP4001, JP4002, JP4003, JP4004, JP4005,  
JP4006, JP4007, JP4008, JP4009, JP4010,  
JP4011, JP4012, JP4013, JP4014, JP4015,  
JP4016

3 J5 J 70600005 22GA JUMPER WIRES T&R

JP5000, JP5001, JP5002

1 J6 J 70600005 22GA JUMPER WIRES T&R

JP6000

1 J7 J 70600005 22GA JUMPER WIRES T&R

JP7000

5 J8 J 70600005 22GA JUMPER WIRES T&R

JP8000, JP8001, JP8002, JP8004, JP8006

3 JMP JMP 70600005 22 GA. JUMPER WIRE T&R

J15, P2, P4

1 KBU6J 70400605 70400605 6A, 600V, INLINE DIODE BRIDGE RECTIFIER

BR1

3 MMPU 73711812 73711812 R93-12 PN C.B. MALE MOLEX PIN

J6, J8, J21

1 PRASW PRASW 71322289 DPDT P/P CB MNT SWITCH

S1

4 RAMN6322 71466322 71466322 JACK MONO R/A 1/4" 6.5MM NINS

J1, J2, J3, J4

1 SPX8 SPX8 XXXXXXXX 8 EACH OF STAKE PINS

J5

1 TB1129 70901129 70901129 2455R-8082-723 95 DEGREE THERMAL BREAKER

TB1

1 TP XXXXXXXX XXXXXXXX

TP1000

2 WJ6WH8 91090507 91090507 WH--16G--8"--WJ6--WJ6

J777, J778

2 WJ8BK5SP WJ8BK5SP 91090506 BK-18G-5"-CPT-250SPD/RA

J11, J12

1 WJ8BL14 WJ8BL14 91014148 BL-18G-14"-CPT-205SPD

J14

1 WJ8YL14 WJ8YL14 91015149 YL-18G-14"-CPT-205SPD

J10

\*\*\*\*\*  
\* END OF BILL OF MATERIALS REPORT \*  
\*\*\*\*\*



8 7 6 5 4 3 2 1

D C B A

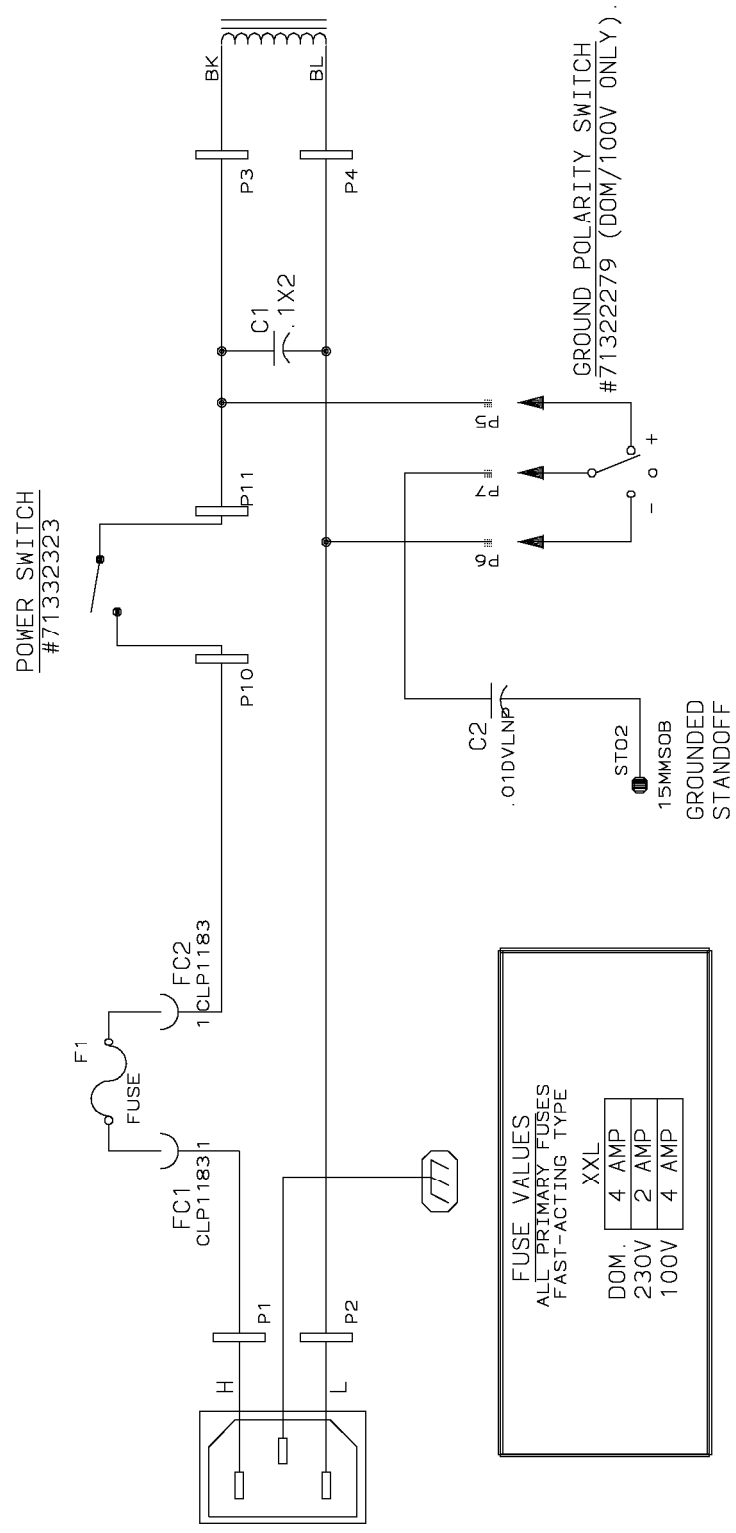

FUSE VALUES  
ALL PRIMARY FUSES  
FAST-ACTING TYPE

DOM.	4 AMP
230V	2 AMP
100V	4 AMP

XXL

**NOTICE:**  
C2, P5, F6, AND P7 INSERTED ON DOMESTIC AND 10CV UNITS ONLY.

N/C STO1 15MSOW

"COMPANY PROPRIETARY INFORMATION"  
Peavey Electronics Corp.  
711 A Street  
Meridian, MS 39301

TITLE  
XXL PRIMARY BOARD

SIZE A	CODE JCF	NUMBER 99098000 (120V) 99098001 (230V)	REV A
PRINT DATE	6-DEC-2001		SHEET 1 OF 1

8 7 6 5 4 3 2 1

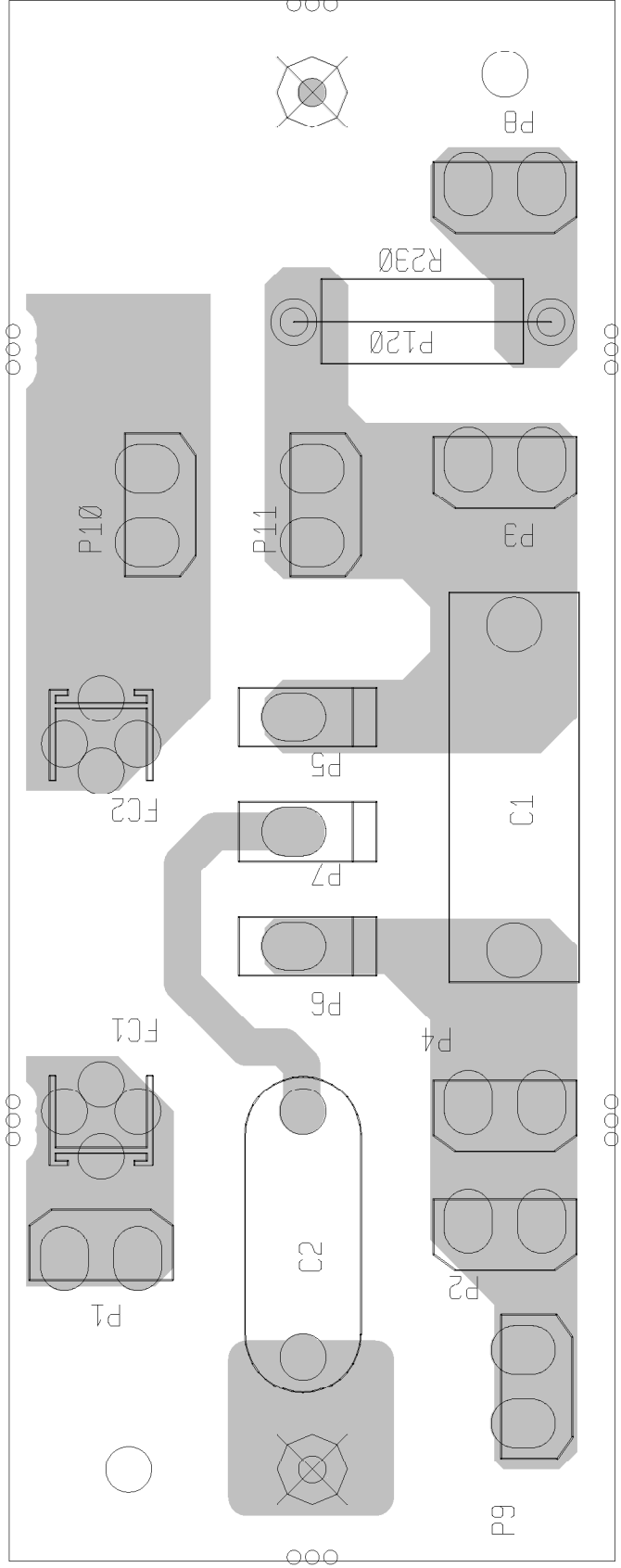

DEVICES NOT PLACED FOR ASSEMBLIES:

9909800 - P8, P9, P120 AND R230

99098001 - C2, P5, P6, P7, P8, P9, P120 AND R230

99099632 - R230

99099633 - C2, P5, P6, P7, P120

BILL OF MATERIALS REPORT

BOARD NAME: XXL PRIM REPORT DATE: 7DEC01  
ASSEMBLY LEVEL NUMBER: 99098000/01  
PROJECT NUMBER: P0000113  
CBDS

PART PART DESCRIPTION AND  
\*\* QTY. NAME VALUE NUMBER DEVICE DESIGNATIONS \*\*\*\*\*  
\*\*\*\*\*

1 98899631 98899631 98899631 PCB

1 .01DVLNP .01DVLNP 70320104 .01 MFD 125VDC DVL MYLAR +0-20%

C2

1 .1X2 70320298 70320298 .1MF 250VAC X2 20%

C1

1 15MMSOB 70901889 70901889 SPACER, 15MM, .187 BRASS

STO2

1 15MSOW 70901837 70901837 SPACER, 15mm-r(#4) .187 swage alum.

STO1

2 CLP1183 CLP1183 70901183 FUSECLIP, PC MT - T&A

FC1, FC2

6 SPD 73716194 73716194 .250 PC MNT SPADE .093 PCB

P1, P2, P3, P4, P10, P11

3 SPX1U SPX1U 73717003 1 STAKE PIN

P5, P6, P7

\*\*\*\*\*  
\* END OF BILL OF MATERIALS REPORT \*  
\*\*\*\*\*