

## DC/DC CONVERTER CONTROL CIRCUITS

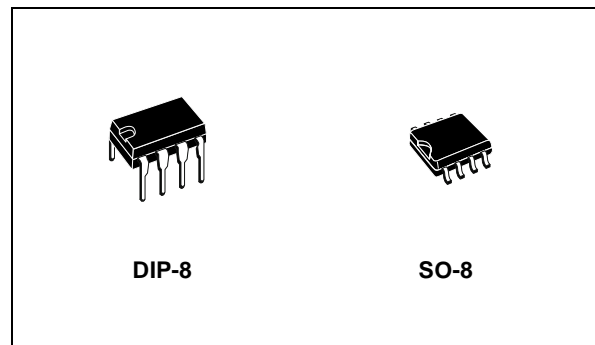
- OUTPUT SWITCH CURRENT IN EXCESS OF 1.5A
- 2% REFERENCE ACCURACY
- LOW QUIESCENT CURRENT: 2.5mA (TYP.)
- OPERATING FROM 3V TO 40V
- FREQUENCY OPERATION TO 100KHz
- ACTIVE CURRENT LIMITING

### DESCRIPTION

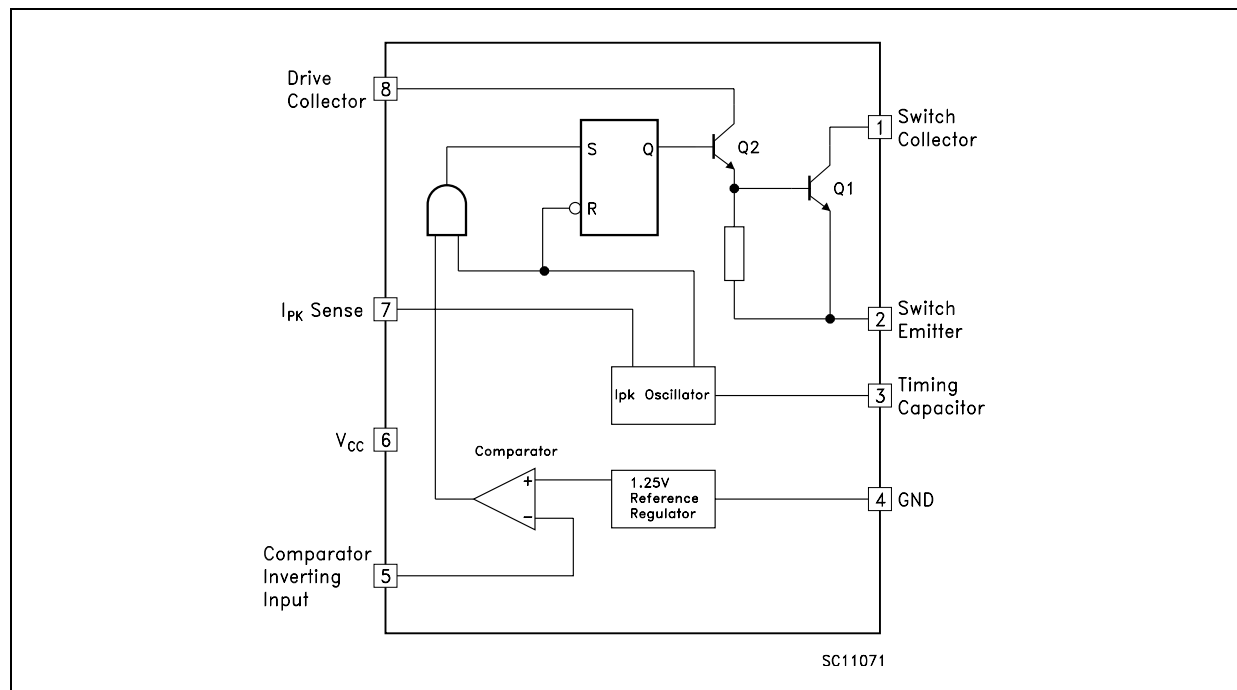
The MC34063A/E series is a monolithic control circuit delivering the main functions for DC/DC voltage converting.

The device contains an internal temperature compensated reference, comparator, duty cycle controlled oscillator with an active current limit circuit, driver and high current output switch. Output voltage is adjustable through two external resistors with a 2% reference accuracy.

Employing a minimum number of external components the MC34063A/E devices series is designed for Step-Down, Step-Up and Voltage-Inverting applications.



### BLOCK DIAGRAM



**ABSOLUTE MAXIMUM RATINGS**

Symbol	Parameter	Value	Unit	
V <sub>CC</sub>	Power Supply Voltage	50	V	
V <sub>IR</sub>	Comparator Input Voltage Range	-0.3 to 40	V	
V <sub>SWC</sub>	Switch Collector Voltage	40	V	
V <sub>SWE</sub>	Switch Emitter Voltage (V <sub>SWC</sub> = 40V)	40	V	
V <sub>CE</sub>	Switch Collector to Emitter Voltage	40	V	
V <sub>DC</sub>	Driver Collector Voltage	40	V	
I <sub>DC</sub>	Driver Collector Current	100	mA	
I <sub>SW</sub>	Switch Current	1.5	A	
P <sub>TOT</sub>	Power Dissipation at T <sub>A</sub> = 25°C	for DIP-8	1.25	W
		for SO-8	0.625	
T <sub>J</sub>	Operating Junction Temperature	150	°C	
T <sub>STG</sub>	Storage Temperature Range	-40 to 150	°C	
T <sub>OP</sub>	Operating Ambient Temperature Range	for AC and EC SERIES	0 to 70	°C
		for AB SERIES	-40 to 85	
		for EB SERIES	-40 to 125	

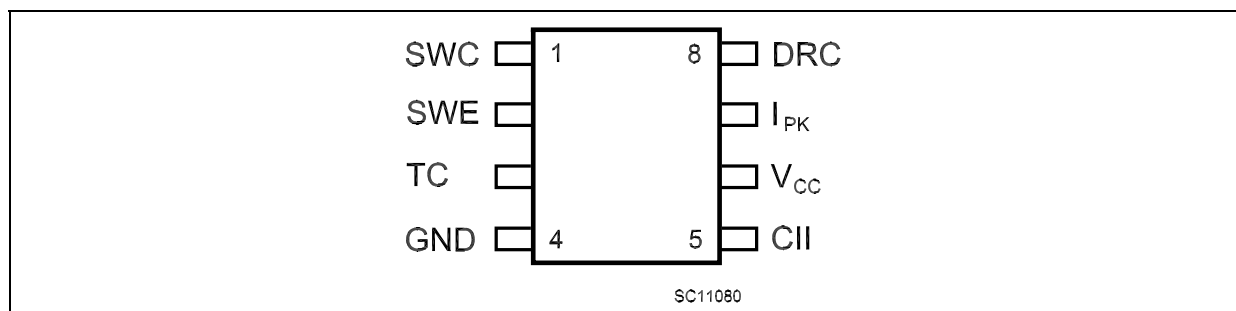
Absolute Maximum Ratings are those values beyond which damage to the device may occur. Functional operation under these condition is not implied.

**THERMAL DATA**

Symbol	Parameter	DIP-8	SO-8	Unit
R <sub>thj-amb</sub>	Thermal Resistance Junction-ambient (*)	100	160	°C/W
R <sub>thj-case</sub>	Thermal Resistance Junction-case	42	20	°C/W

(\*) This value depends from thermal design of PCB on which the device is mounted.

**CONNECTION DIAGRAM (top view)**



**PIN DESCRIPTION**

Pin N°	Symbol	Name and Function
1	SWC	Switch Collector
2	SWE	Switch Emitter
3	TC	Timing Capacitor
4	GND	Ground
5	CII	Comparator Inverting Input
6	V <sub>CC</sub>	Voltage Supply
7	I <sub>PK</sub>	I <sub>PK</sub> Sense
8	DRC	Voltage Driver Collector

## ORDERING CODES

TYPE	DIP-8	SO-8	SO-8 (TAPE & REEL)
MC34063AB	MC34063ABN	MC34063ABD	MC34063ABD-TR
MC34063AC	MC34063ACN	MC34063ACD	MC34063ACD-TR
MC34063EB	MC34063EBN	MC34063EBD	MC34063EBD-TR
MC34063EC	MC34063ECN	MC34063ECD	MC34063ECD-TR

(\*) The "A" version is not recommended for new designs.

**ELECTRICAL CHARACTERISTICS** (Refer to the test circuits,  $V_{CC} = 5V$ ,  $T_A = T_{LOW}$  to  $T_{HIGH}$ , unless otherwise specified, see note 2)

## OSCILLATOR

Symbol	Parameter	Test Conditions	Min.	Typ.	Max.	Unit
$f_{OSC}$	Frequency	$V_{PIN5} = 0V$ $C_T = 1 nF$ $T_A = 25^\circ C$	24	33	42	KHz
$I_{CHG}$	Charge Current	$V_{CC} = 5$ to $40V$ $T_A = 25^\circ C$	24	33	42	$\mu A$
$I_{DISCHG}$	Discharge Current	$V_{CC} = 5$ to $40V$ $T_A = 25^\circ C$	140	200	260	$\mu A$
$I_{DISCHG}/I_{CHG}$	Discharge to Charge Current Ratio	$PIN 7 = V_{CC}$ $T_A = 25^\circ C$	5.2	6.2	7.5	$\mu A$
$V_{IPK(sense)}$	Current Limit Sense Voltage	$I_{CHG} = I_{DISCHG}$ $T_A = 25^\circ C$	250	300	350	mV

## OUTPUT SWITCH

Symbol	Parameter	Test Conditions	Min.	Typ.	Max.	Unit
$V_{CE(sat)}$	Saturation Voltage, Darlington Connection	$I_{SW} = 1 A$ $PIN 7, 8$ connected		1	1.3	V
$V_{CE(sat)}$	Saturation Voltage	$I_{SW} = 1 A$ $R_{PIN8} = 82 \Omega$ to $V_{CC}$ Forced $\beta \sim 20$		0.45	0.7	V
$h_{FE}$	DC Current Gain	$I_{SW} = 1 A$ $V_{CE} = 5 V$ $T_A = 25^\circ C$	50	120		
$I_{C(off)}$	Collector Off-State Current	$V_{CE} = 40 V$		0.01	100	$\mu A$

## COMPARATOR

Symbol	Parameter	Test Conditions	Min.	Typ.	Max.	Unit
$V_{TH}$	Threshold Voltage	$T_A = 25^\circ C$	1.225	1.25	1.275	V
		$T_A = T_{LOW}$ to $T_{HIGH}$	1.21		1.29	
$Reg_{line}$	Threshold Voltage Line Regulation	$V_{CC} = 3$ to $40 V$		1	5	mV
$I_{IB}$	Input Bias Current	$V_{IN} = 0 V$		-5	-400	nA

TOTAL DEVICE

Symbol	Parameter	Test Conditions	Min.	Typ.	Max.	Unit	
I <sub>CC</sub>	Supply Current	V <sub>CC</sub> = 5 to 40 V C <sub>T</sub> = 1 nF PIN 7 = V <sub>CC</sub> V <sub>PIN5</sub> > V <sub>TH</sub> PIN 2 = GND Remaining pins open	for MC34063A		2.5	4	mA
			for MC34063E		1.5	4	
V <sub>START-UP</sub>	Start-Up Voltage (Note 4)	T <sub>A</sub> = 25°C C <sub>T</sub> = 1 μF, PIN 5 = 0	for MC34063A		2.1		V
			for MC34063E		1.5		

NOTES:

- 1) Maximum package power dissipation limit must be observed.
- 2) T<sub>LOW</sub> = 0°C, T<sub>HIGH</sub> = 70°C (AC and EC series); T<sub>LOW</sub> = -40°C, T<sub>HIGH</sub> = 85°C (AB series); T<sub>LOW</sub> = -40°C, T<sub>HIGH</sub> = 125°C (EB series).
- 3) If Darlington configuration is not used, care must be taken to avoid deep saturation of output switch. The resulting switch-off time may be adversely affected. In a Darlington configuration the following output driver condition is suggested:  
Forced β of output current switch = I<sub>CCOUTPUT</sub> / (I<sub>CDRIVER</sub> - 1mA\*) ≥ 10  
\* Current less due to a built in 1KΩ anti leakage resistor.
- 4) Start-up Voltage is the minimum Power Supply Voltage at which the internal oscillator begins to work.

TYPICAL PERFORMANCE CHARACTERISTICS

Figure 1 : Emitter Follower Configuration Output Saturation Voltage vs Emitter Current

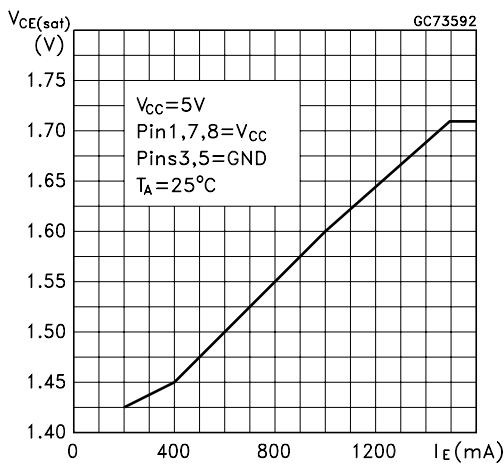


Figure 2 : Output Switch ON-OFF Time vs Oscillator Timing Capacitor

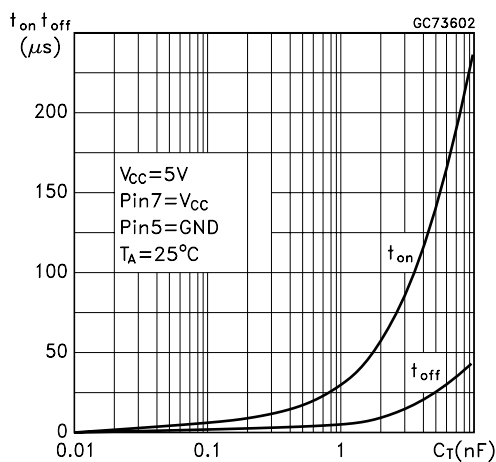


Figure 3 : Common Emitter Configuration Output Switch Saturation Voltage vs Collector Current

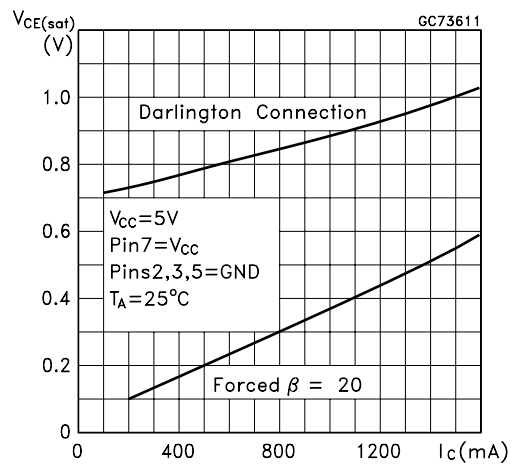
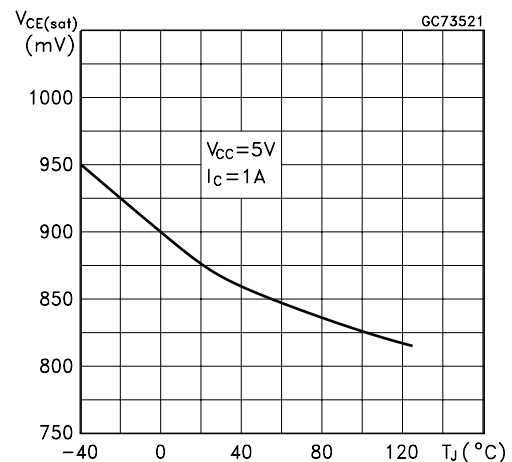
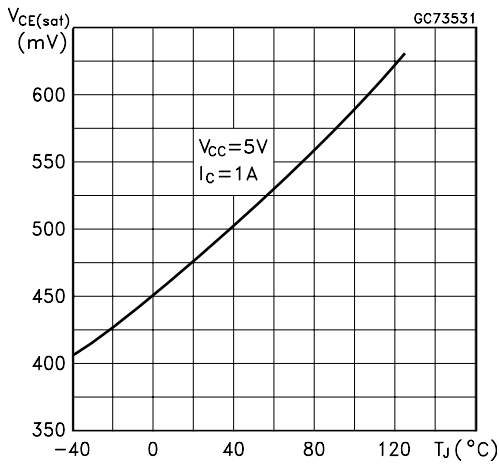


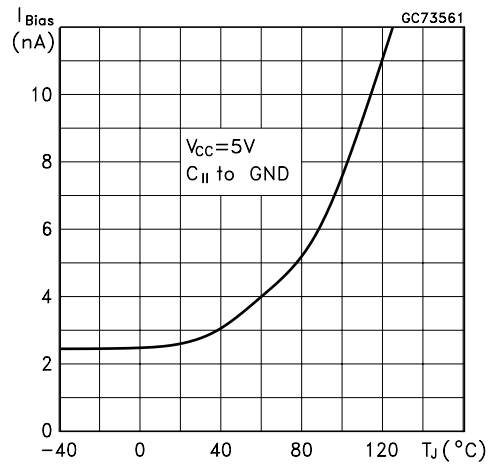
Figure 4 : Darlington Configuration Collector Emitter Saturation Voltage (VCE(sat)) vs Temperature



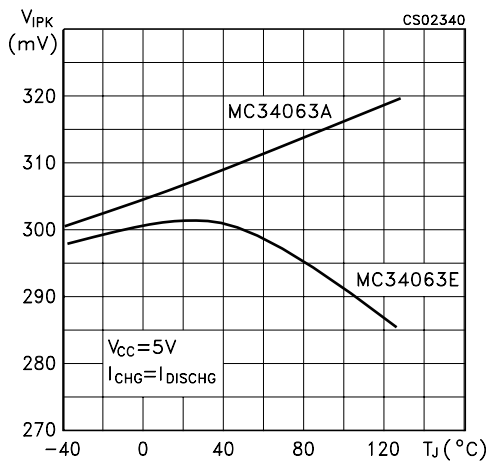
**Figure 5 : Power Collector Emitter Saturation Voltage ( $V_{CEsat}$ ) vs Temperature**



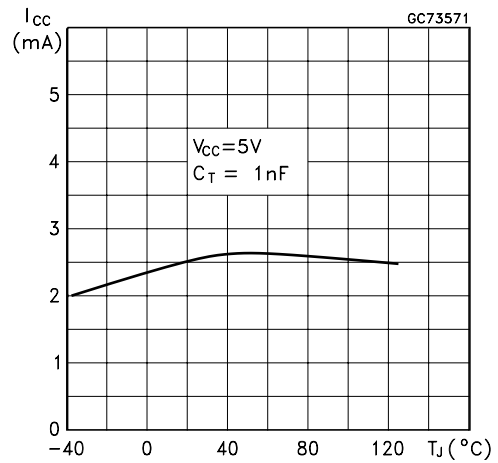
**Figure 8 : Bias Current vs Temperature**



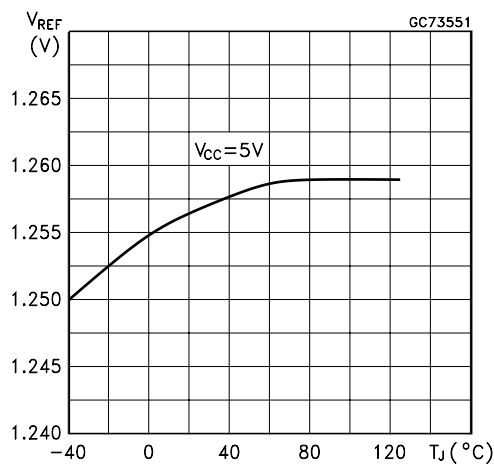
**Figure 6 : Current Limit Sense Voltage ( $V_{IPK}$ ) vs Temperature**



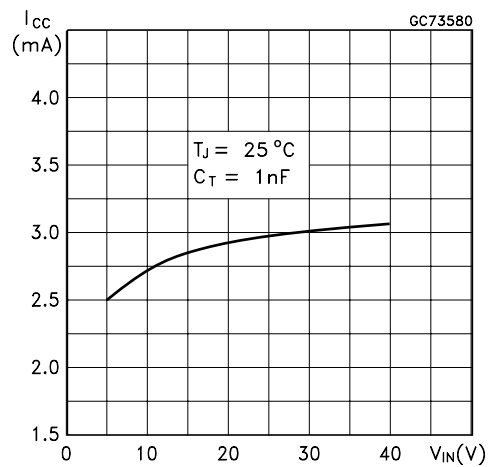
**Figure 9 : Supply Current vs Temperature**



**Figure 7 : Reference Voltage vs Temperature**

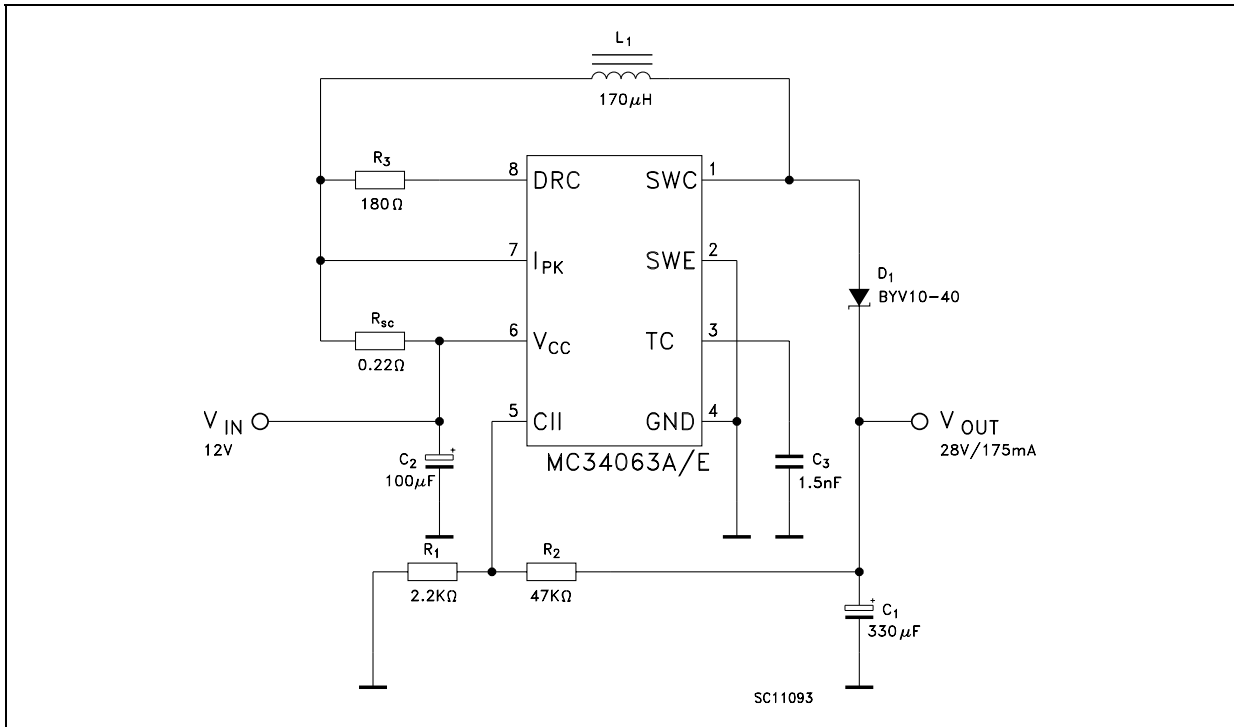


**Figure 10 : Supply Current vs Input Voltage**

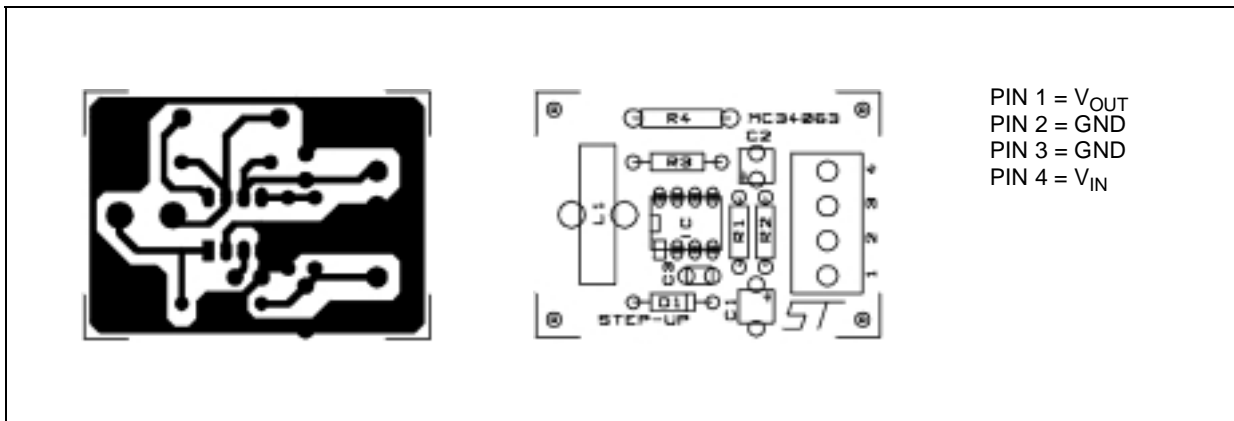


TYPICAL APPLICATION CIRCUIT

Step-UP Converter



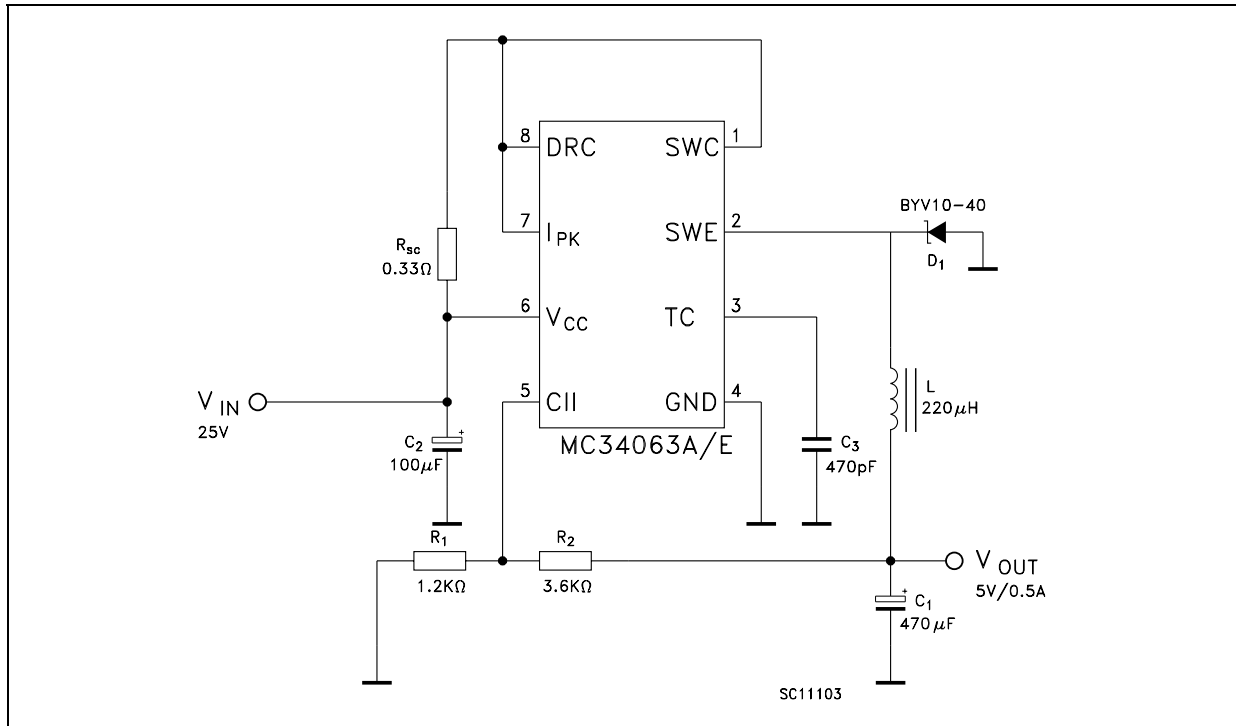
Printed Demoboard



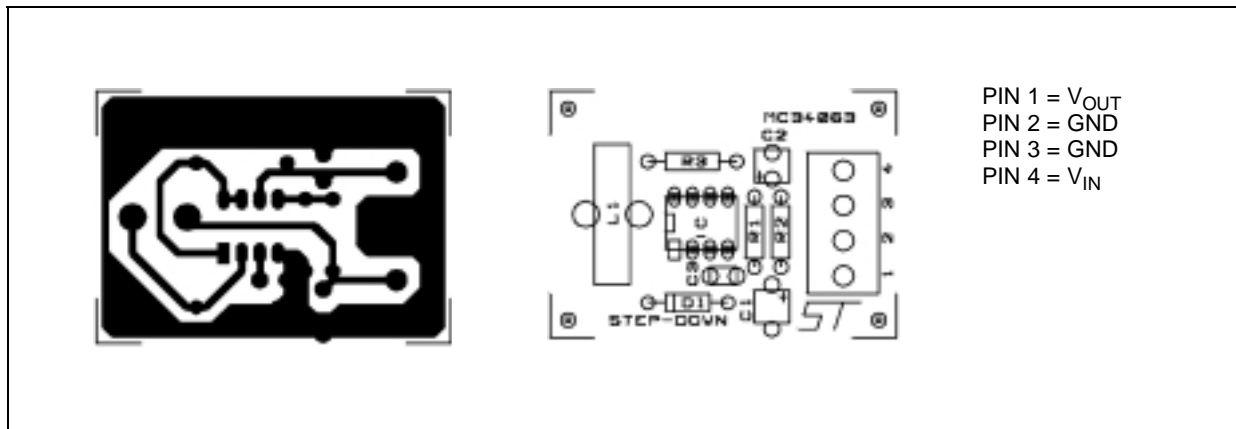
Test Condition (V<sub>OUT</sub> = 28V)

Test	Conditions	Value (Typ.)	Unit
Line Regulation	V <sub>IN</sub> = 8 to 16 V, I <sub>O</sub> = 175 mA	30	mV
Load Regulation	V <sub>IN</sub> = 12 V, I <sub>O</sub> = 75 to 175 mA	10	mV
Output Ripple	V <sub>IN</sub> = 12 V, I <sub>O</sub> = 175 mA	300	mV
Efficiency	V <sub>IN</sub> = 12 V, I <sub>O</sub> = 175 mA	89	%

Step-Down Converter



Printed Demoboard

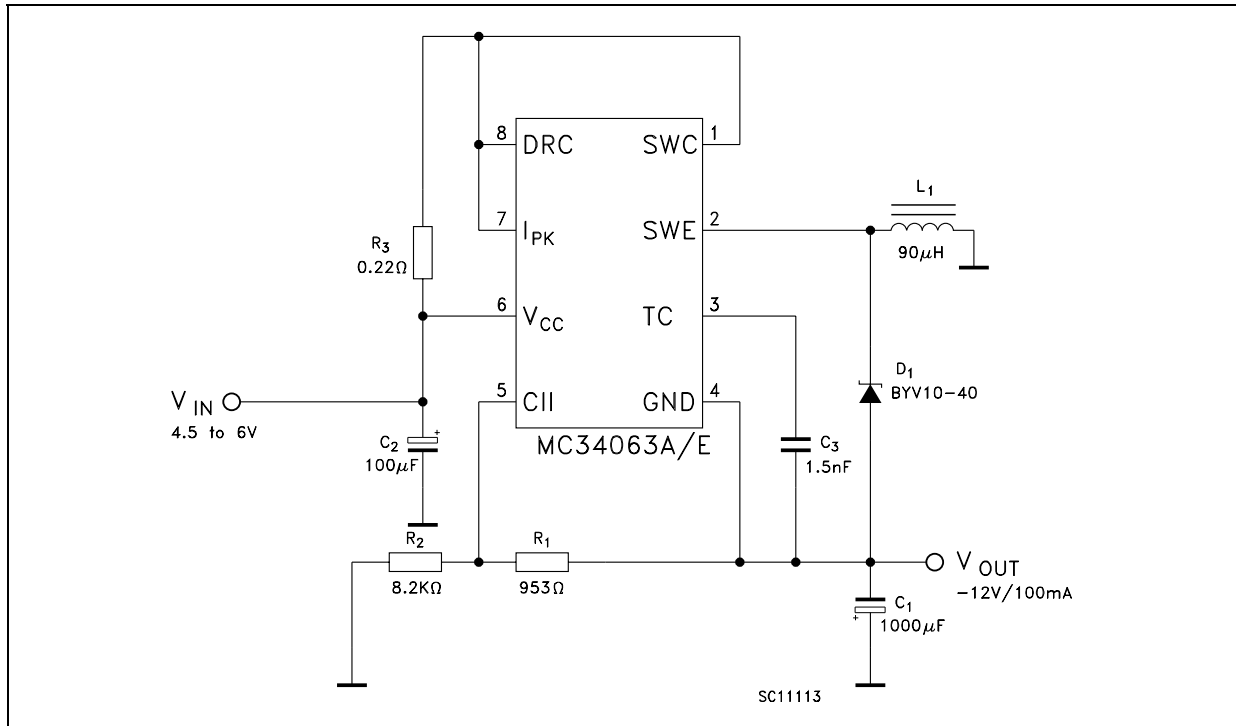


Test Condition ( $V_{OUT} = 5V$ )

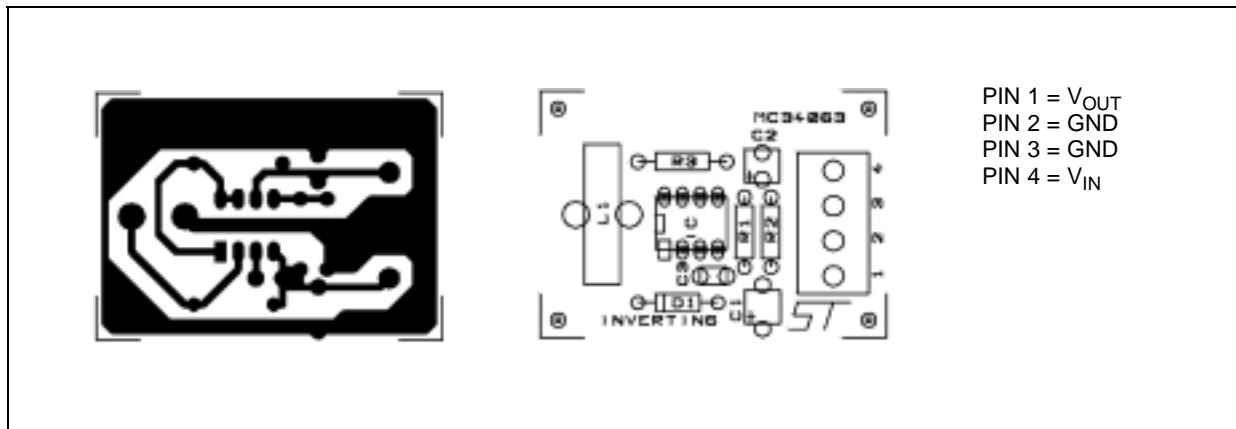
Test	Conditions	Value (Typ.)	Unit
Line Regulation	$V_{IN} = 15$ to $25$ V, $I_O = 500$ mA	5	mV
Load Regulation	$V_{IN} = 25$ V, $I_O = 50$ to $500$ mA	30	mV
Output Ripple	$V_{IN} = 25$ V, $I_O = 500$ mA	100	mV
Efficiency	$V_{IN} = 25$ V, $I_O = 500$ mA	80	%
$I_{SC}$	$V_{IN} = 25$ V, $R_{LOAD} = 0.1$ Ω	1.2	A

# MC34063A/E

## Voltage Inverting Converter



## Printed Demoboard



Test Condition ( $V_{OUT} = -12V$ )

Test	Conditions	Value (Typ.)	Unit
Line Regulation	$V_{IN} = 4.5$ to $6$ V, $I_O = 100$ mA	15	mV
Load Regulation	$V_{IN} = 5$ V, $I_O = 10$ to $100$ mA	20	mV
Output Ripple	$V_{IN} = 5$ V, $I_O = 100$ mA	230	mV
Efficiency	$V_{IN} = 5$ V, $I_O = 100$ mA	58	%
$I_{SC}$	$V_{IN} = 5$ V, $R_{LOAD} = 0.1$ $\Omega$	0.9	A



Calculation

Parameter	Step-Up (Discontinuous mode)	Step-Down (Continuous mode)	Voltage Inverting (Discontinuous mode)
$t_{on}/t_{off}$	$\frac{V_{OUT} + V_F - V_{IN(min)}}{V_{IN(min)} - V_{sat}}$	$\frac{V_{OUT} + V_F}{V_{IN(min)} - V_{sat} - V_{OUT}}$	$\frac{ V_{OUT}  + V_F}{V_{IN} - V_{sat}}$
$(t_{on} + t_{off})_{max}$	$1/f_{min}$	$1/f_{min}$	$1/f_{min}$
$C_T$	$4.5 \times 10^{-5} t_{on}$	$4.5 \times 10^{-5} t_{on}$	$4.5 \times 10^{-5} t_{on}$
$I_{PK(switch)}$	$2I_{out(max)}[(t_{on}/t_{off})+1]$	$2I_{out(max)}$	$2I_{out(max)}[(t_{on}/t_{off})+1]$
$R_{SC}$	$0.3/I_{PK(switch)}$	$0.3/I_{PK(switch)}$	$0.3/I_{PK(switch)}$
$C_O$	$\frac{I_{out} t_{on}}{V_{ripple(p-p)}}$	$\frac{I_{PK(switch)}(t_{on} + t_{off})}{8V_{ripple(p-p)}}$	$\frac{I_{out} t_{on}}{V_{ripple(p-p)}}$
$L_{(min)}$	$\frac{V_{IN(min)} - V_{sat}}{I_{PK(switch)}} \times t_{on(min)}$	$\frac{V_{IN(min)} - V_{sat} - V_{out}}{I_{PK(switch)}} \times t_{on(min)}$	$\frac{V_{IN(min)} - V_{sat}}{I_{PK(switch)}} \times t_{on(min)}$

NOTES:

$V_{SAT}$  = Saturation voltage of the output switch

$V_F$  = Forward voltage drop of the output rectifier

THE FOLLOWING POWER SUPPLY CHARACTERISTICS MUST BE CHOSEN:

$V_{IN}$  = Nominal input voltage

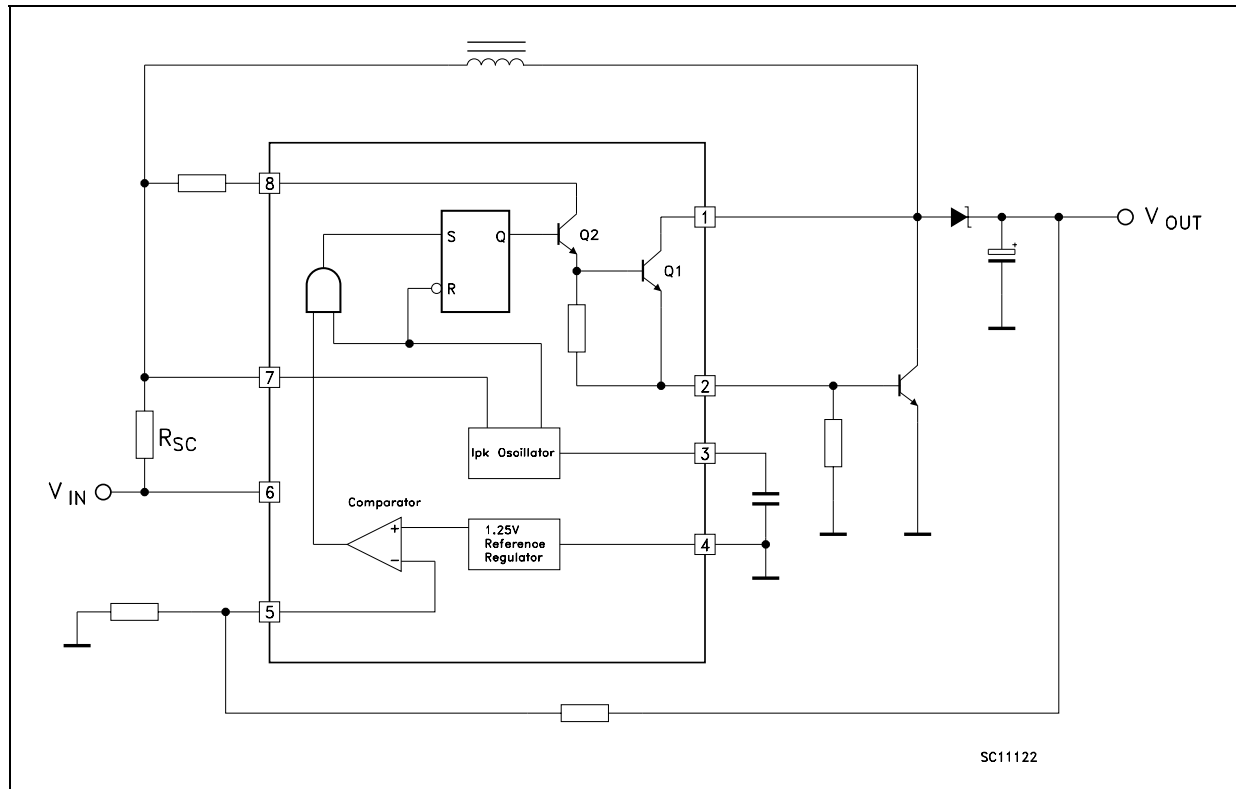
$V_{OUT}$  = Desired output voltage,  $|V_{OUT}| = 1.25(1+R_2/R_1)$

$I_{OUT}$  = Desired output current

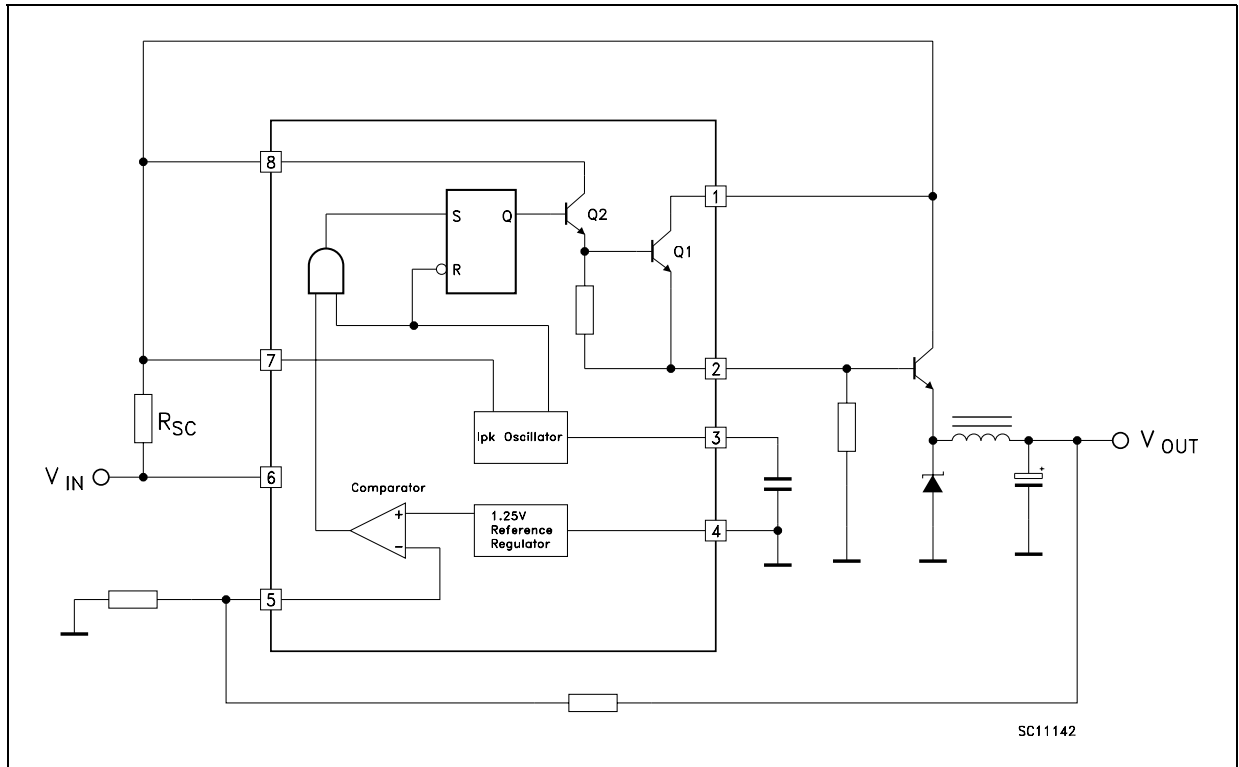
$f_{MIN}$  = Minimum desired output switching frequency at the selected values of  $V_{IN}$  and  $I_O$

$V_{RIPPLE}$  = Desired peak to peak output ripple voltage. In practice, the calculated capacitor value will need to be increased due to its equivalent series resistance and board layout. The ripple voltage should be kept to a low value since it will directly affect the line and load regulation.

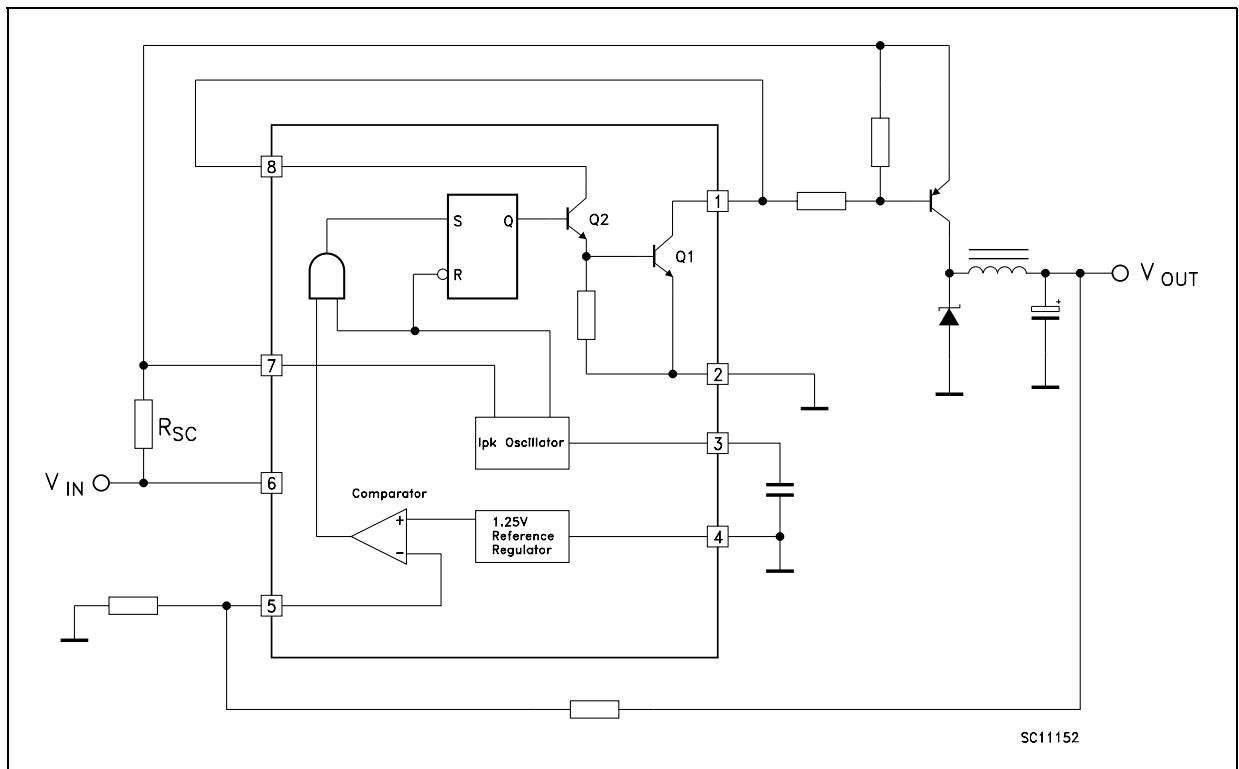
Step-Up With External NPN Switch



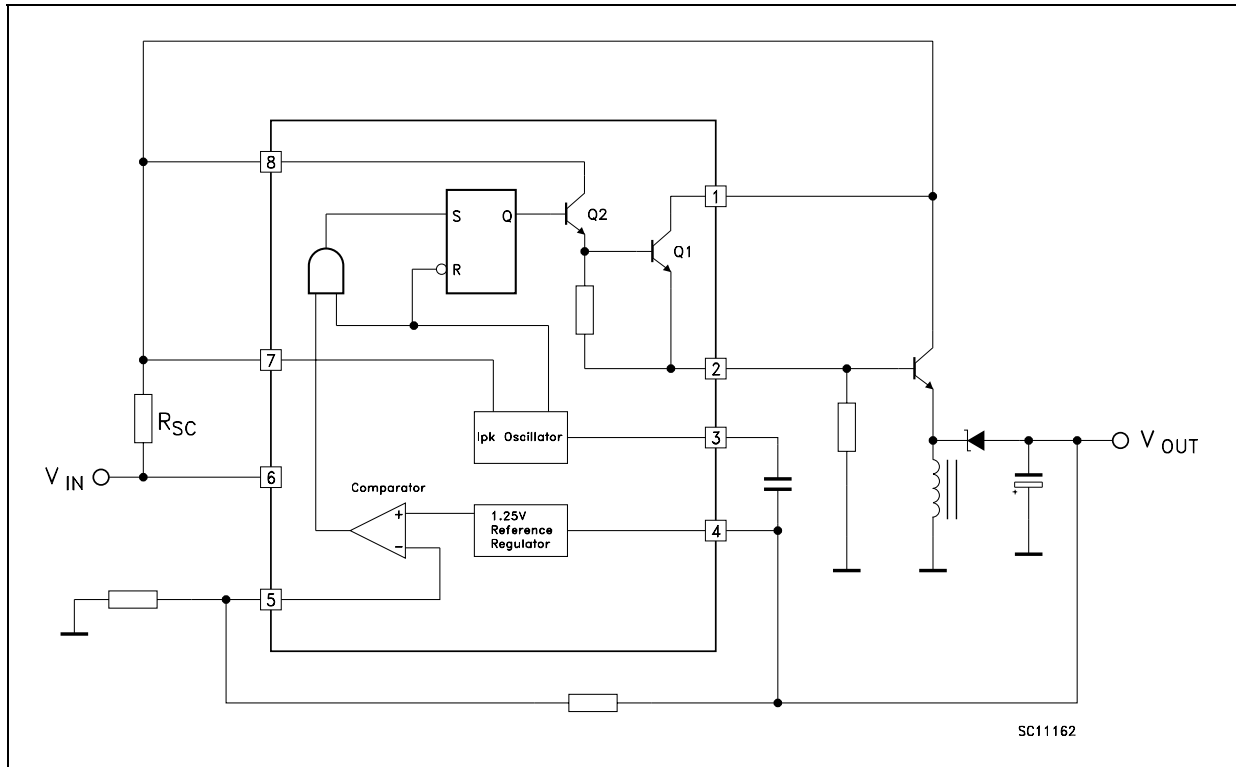
Step-Down With External NPN Switch



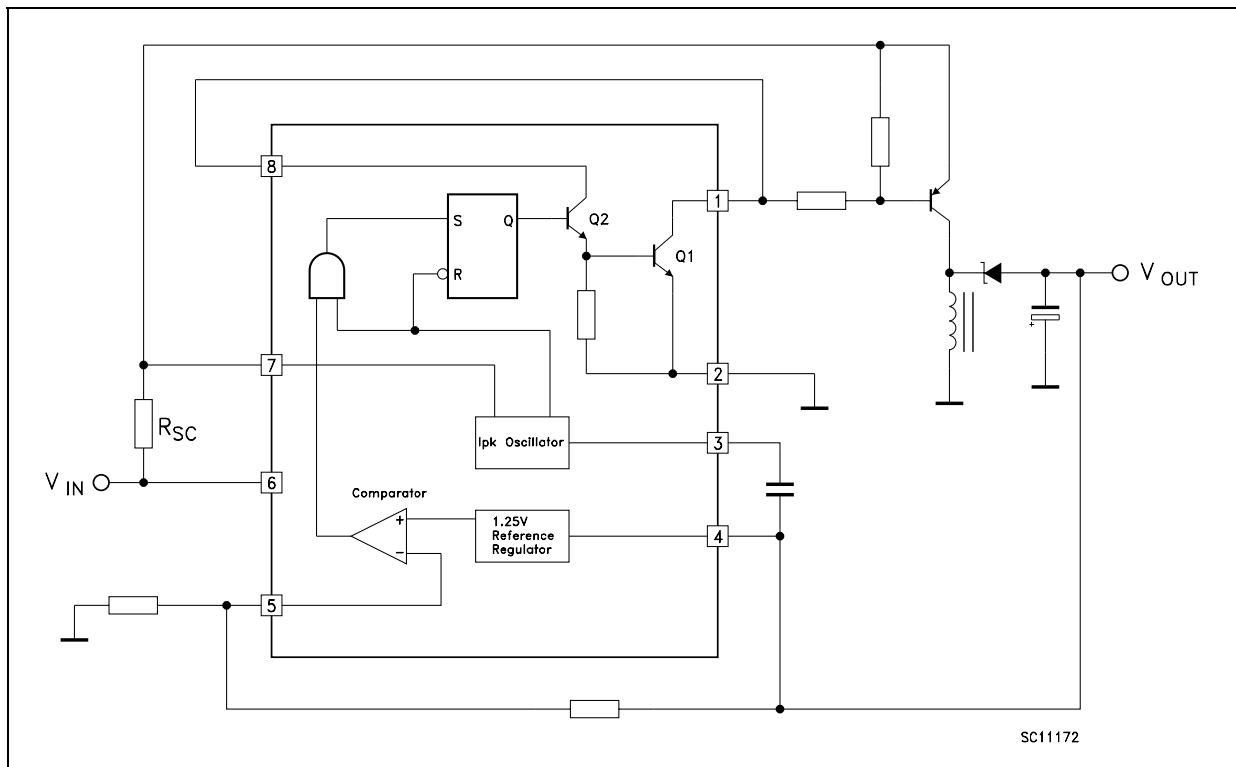
Step-Down With External PNP Switch



Voltage Inverting With External NPN Switch



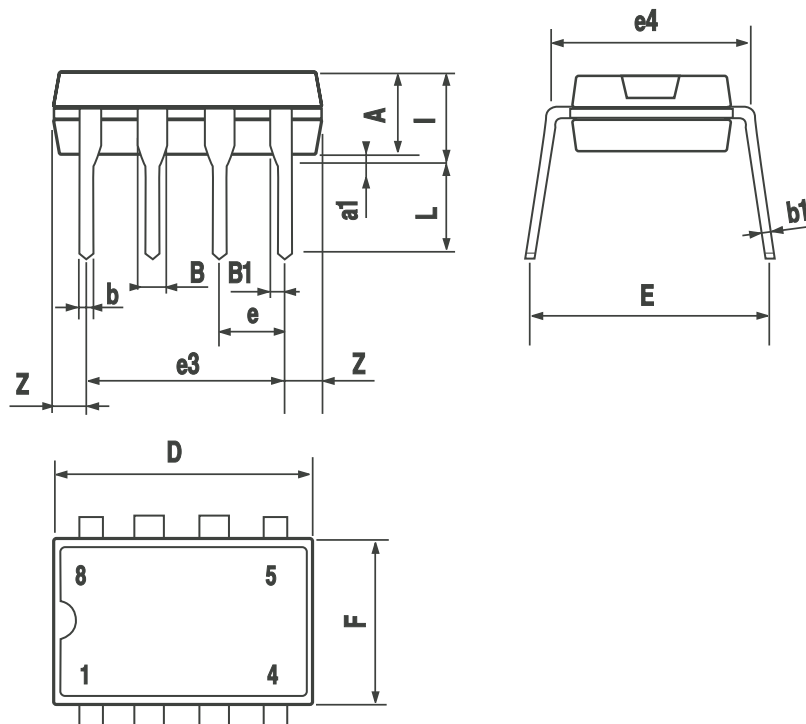
Voltage Inverting With External PNP Saturated Switch





<b>Plastic DIP-8 MECHANICAL DATA</b>						
--------------------------------------	--	--	--	--	--	--

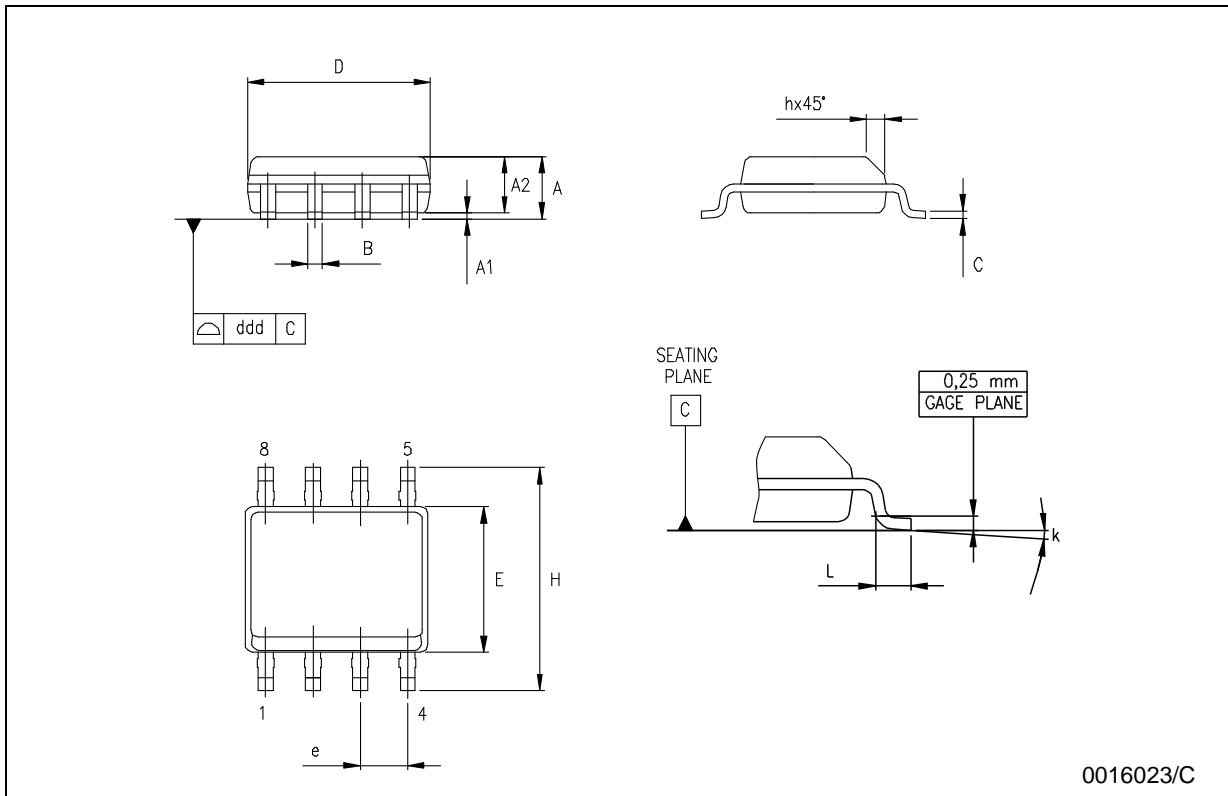
DIM.	mm.			inch		
	MIN.	TYP.	MAX.	MIN.	TYP.	MAX.
A		3.3			0.130	
a1	0.7			0.028		
B	1.39		1.65	0.055		0.065
B1	0.91		1.04	0.036		0.041
b		0.5			0.020	
b1	0.38		0.5	0.015		0.020
D			9.8			0.386
E		8.8			0.346	
e		2.54			0.100	
e3		7.62			0.300	
e4		7.62			0.300	
F			7.1			0.280
I			4.8			0.189
L		3.3			0.130	
Z	0.44		1.6	0.017		0.063



P001F

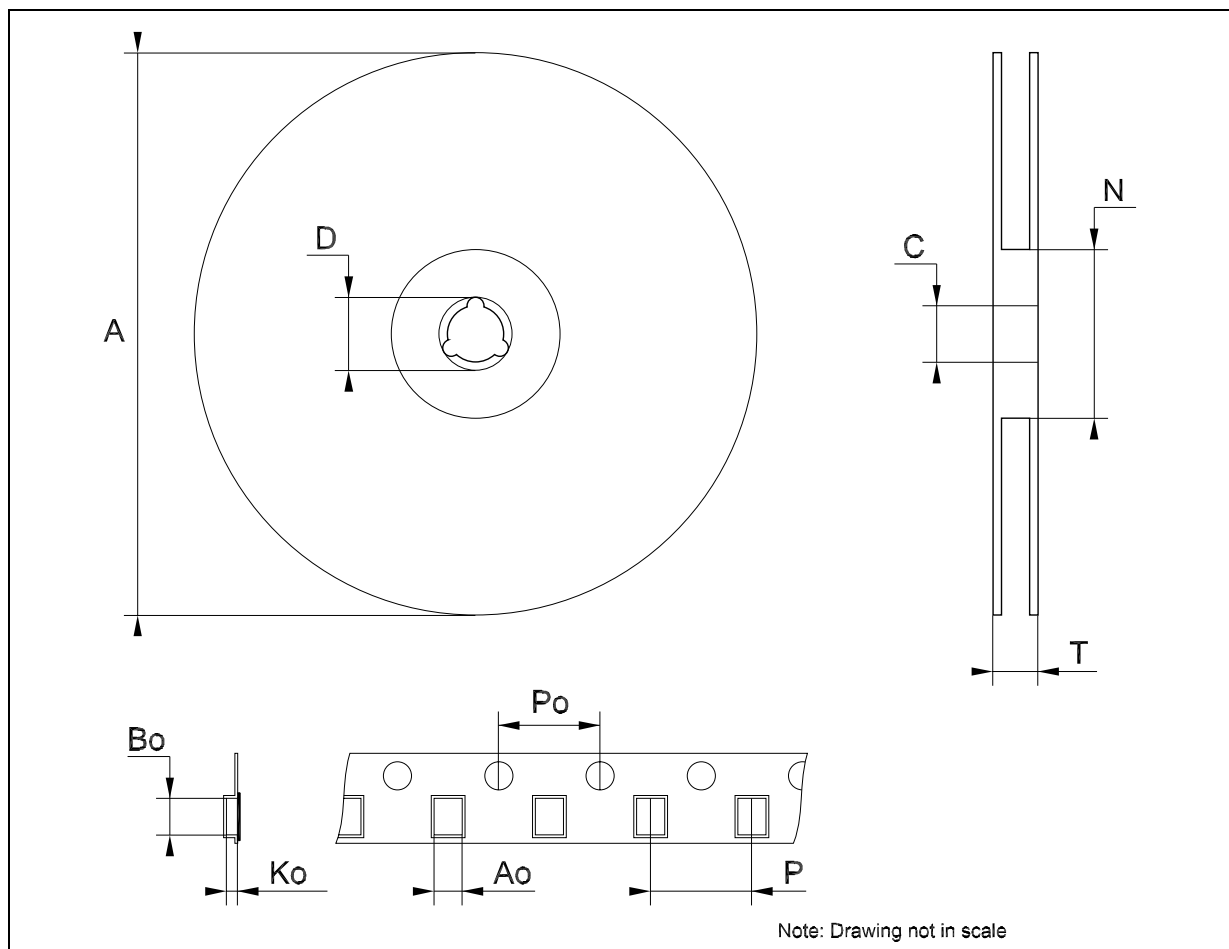
**SO-8 MECHANICAL DATA**

DIM.	mm.			inch		
	MIN.	TYP.	MAX.	MIN.	TYP.	MAX.
A	1.35		1.75	0.053		0.069
A1	0.10		0.25	0.04		0.010
A2	1.10		1.65	0.043		0.065
B	0.33		0.51	0.013		0.020
C	0.19		0.25	0.007		0.010
D	4.80		5.00	0.189		0.197
E	3.80		4.00	0.150		0.157
e		1.27			0.050	
H	5.80		6.20	0.228		0.244
h	0.25		0.50	0.010		0.020
L	0.40		1.27	0.016		0.050
k	8° (max.)					
ddd			0.1			0.04



## Tape &amp; Reel SO-8 MECHANICAL DATA

DIM.	mm.			inch		
	MIN.	TYP	MAX.	MIN.	TYP.	MAX.
A			330			12.992
C	12.8		13.2	0.504		0.519
D	20.2			0.795		
N	60			2.362		
T			22.4			0.882
Ao	8.1		8.5	0.319		0.335
Bo	5.5		5.9	0.216		0.232
Ko	2.1		2.3	0.082		0.090
Po	3.9		4.1	0.153		0.161
P	7.9		8.1	0.311		0.319



Information furnished is believed to be accurate and reliable. However, STMicroelectronics assumes no responsibility for the consequences of use of such information nor for any infringement of patents or other rights of third parties which may result from its use. No license is granted by implication or otherwise under any patent or patent rights of STMicroelectronics. Specifications mentioned in this publication are subject to change without notice. This publication supersedes and replaces all information previously supplied. STMicroelectronics products are not authorized for use as critical components in life support devices or systems without express written approval of STMicroelectronics.

The ST logo is a registered trademark of STMicroelectronics  
All other names are the property of their respective owners

© 2004 STMicroelectronics - All Rights Reserved  
STMicroelectronics GROUP OF COMPANIES

Australia - Belgium - Brazil - Canada - China - Czech Republic - Finland - France - Germany - Hong Kong - India - Israel - Italy - Japan -  
Malaysia - Malta - Morocco - Singapore - Spain - Sweden - Switzerland - United Kingdom - United States.

<http://www.st.com>



This datasheet has been download from:

[www.datasheetcatalog.com](http://www.datasheetcatalog.com)

Datasheets for electronics components.