



APPLICATIONS

- OA Equipment: Printers/Scanners
- Industrial equipment: Flow control valves
- Automotive: Meters/Optic axis control device
- Home automation appliances: Sewing machines

SPECIFICATIONS

Reference characteristics

Motor Size	PM35L-048	
Number of Steps per Rotation	48 (7.5° / Step)	
Drive Method	2-2 PHASE	
Drive Circuit	UNIPOLAR CONST. VOLT.	BIPOLAR CHOPPER
Drive Voltage	24[V]	24[V]
Current / Step	500[mA]	
Coil Resistance / Step	30[Ω]	5.5[Ω]
Drive I C	2SC3346	UDN2916B-V
Magnet Material	Ferrite plastic magnet (MSPL) Polar anisotropy ferrite sintered magnet (MS50) Nd-Fe-B bonded magnet (MS70)	
Insulation Resistance	100M[Ω] MIN	
Dielectric Strength	AC 500[V] 1[min]	
Class of Insulation	CLASS E	
Operating Temp.	-10[°C] ~ 50[°C]	
Storage Temp.	-30[°C] ~ 80[°C]	
Operating Hum.	20[%] RH ~ 90[%] RH	

Torque characteristics

PM35L-048 UNI-CONST. V(at 24[V],30[Ω])

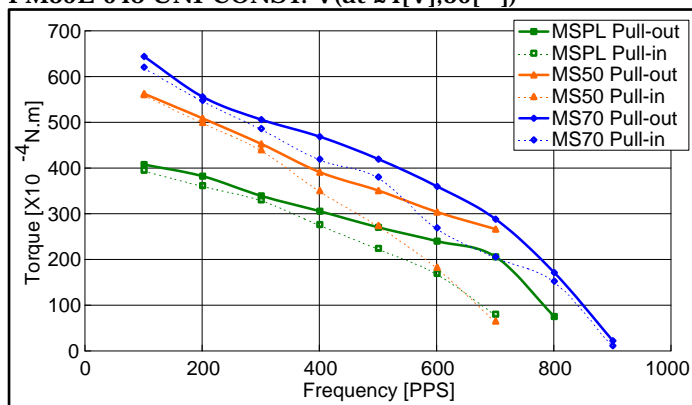

PM35L-048 BI-CHOPPER(at 24[V],5.5[Ω],500[mA])

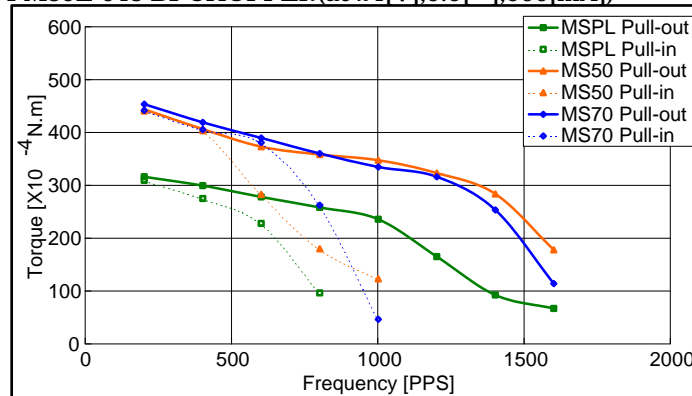

These characteristic are general reference values. When using motors, factors such as heat radiation conditions and duty effect heat rise, therefore please select motors after considering the heat conditions in the actual equipment.

Dimensions

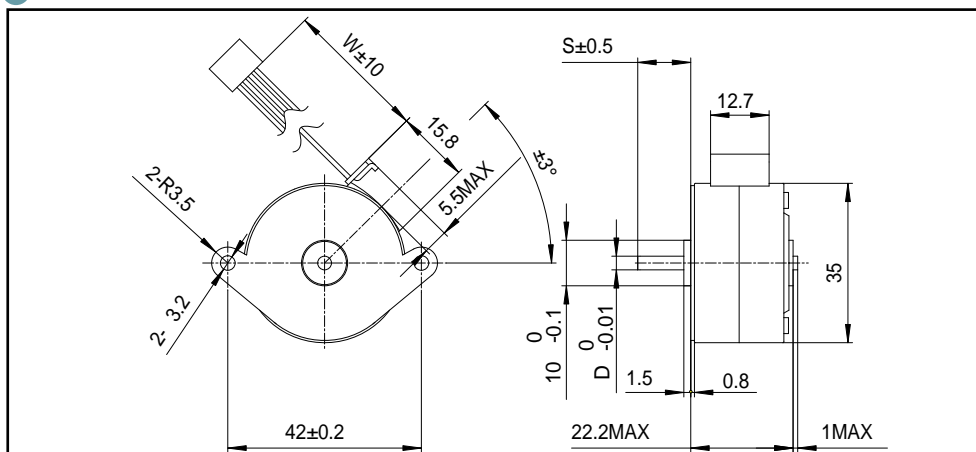

If you would like to know this Dimensions(D,S,W,),Please see Standard Dimensions in our Home Page.