

## General Description

The Rane MLM 82a features four balanced, studio grade, MONO MIC/LINE INPUTS with XLR jacks and 15 VDC phantom power. *Each of the four MIC/LINE inputs may be assigned to A, A+B or B outputs.* Independent Level/Gain Trim controls and Signal/Overload indicators are provided for each MIC/LINE input. The Phantom Power switch and the MIC/LINE switches are located on the rear panel. Phantom power is removed from any input set for LINE operation.

The MLM 82a also features four stereo line level inputs with 12 dB of line gain. Each STEREO LINE INPUT features a recessed MONO switch with indicator and LEVEL control.

These inputs may also be used with four mono A inputs and four mono B inputs. You get the picture... this mixer is very versatile.

A and B OUTPUT LEVEL controls set the master mix level independently for A and B outputs. The mix amplifiers feature independent overload indicators. To correct any overload condition, the entire mix can be reduced and/or individual input levels adjusted. A and B mix OUTPUTS each have an internal switch for padding the output signal to MIC level. The factory default is LINE level.

## Features

- *New!* A/A+B/B assign switch for each Mic/Line Input
- *New!* Independent Mono switch for each Stereo Line Input
- *New!* 12 dB of line gain for each Stereo Line Input
- *New!* Individual Level control hole plugs included
- Four balanced Mic/Line Inputs (XLR) with...
  - 15 volt phantom power
  - Bi-Color Signal Present/Overload indicators
  - Trimless Mic Stage Preamplifiers
- Four balanced, Stereo Line Inputs (TRS)
- Two balanced Outputs (XLR) with...
  - Independent Overload indicators
  - Independent Level controls
  - Internal Pad for Mic level output
- UL/CSA/CE and 100/120/230 VAC Remote Power Supplies



**Features and Specifications**

Parameter	Specification	Limit	Units	Conditions/Comments
Inputs: Type	Active Balanced			
.....Connectors	XLR / ¼" TRS			Mic / Stereo Line
Mic / Line Input Impedance	1k / 96k	1%	ohms	Balanced 500+500 / 48k + 48k
.....Mic Gain Range	off to +60	±1.5	dB	
.....Line Gain Range	off to +20	±1.5	dB	
.....Equivalent Input Noise	-128	typ	dBu	20 kHz bandwidth, 150 ohm termination
.....THD & Noise	0.02	max	%	Gain=40 dB, +4 dBu@1 kHz, 80 Hz BW
.....Frequency Response	30 Hz - 35 kHz	-3	dB	
Stereo Line Input Impedance	20k	min	ohms	
.....Gain Range	off to +12	±1	dB	
.....Signal-To-Noise Ratio	90	typ	dB	Unity gain, output@+4 dBu, 22 kHz BW
.....Frequency Response	10 Hz - 35 kHz	-3	dB	
.....THD & Noise	0.007	max	%	+4 dBu at 1 kHz, 80 kHz BW
Outputs: Type	Active Balanced			
.....Connectors	XLR			
.....Impedance	200/100	1%	ohms	Line level Out/Mic level Out
.....Gain Range	Off to +6	±2	dB	
.....Drive Level	+24		dBu	600 ohm load balanced
Phantom Power	+15	4%	VDC	
Output Cable Length	1500	typ	feet	Line-level, <50 pFper foot
Crosstalk	-75 @ 1 kHz	max	dB	re +4 dBu any channel to any channel
Unit: Agency Listing				
.....120 VAC model	Class 2 Equipment UL CSA			National Electrical Code Exempt Class 2 equipment Exempt Class 2 equipment
.....230 VAC model	CE-EMC CE-Safety			EMC directive 89/336/EEC Exempt per Art. 1 of LVD 73/23/EEC
Power Supply: Agency Listing				
.....120 VAC model	UL CSA			Class 2 Equipment File no. E88261 File no. LR58948
.....230 VAC model	CE-EMC CE-Safety			EMC directive 89/336/EEC LV directive 73/23/EEC
Power Supply Requirement	18 VAC w/center tap	10%	Vrms	RS 1 (see data sheet)
.....Maximum Current	600		mA	RMS Current from Remote Supply
Unit: Construction	All Steel			
.....Size	1.75"H x 19"W x 5.3"D (1U)			(4.4 cm x 48.3 cm x 13.3 cm)
.....Weight	4 lb			(3 kg)
Shipping: Size	4.25" x 20.3" x 13.75"			(11 cm x 52 cm x 35 cm)
.....Weight	8 lb			(5 kg)
<i>Note: 0 dBu=0.775 Vrms</i>				

### Block Diagram

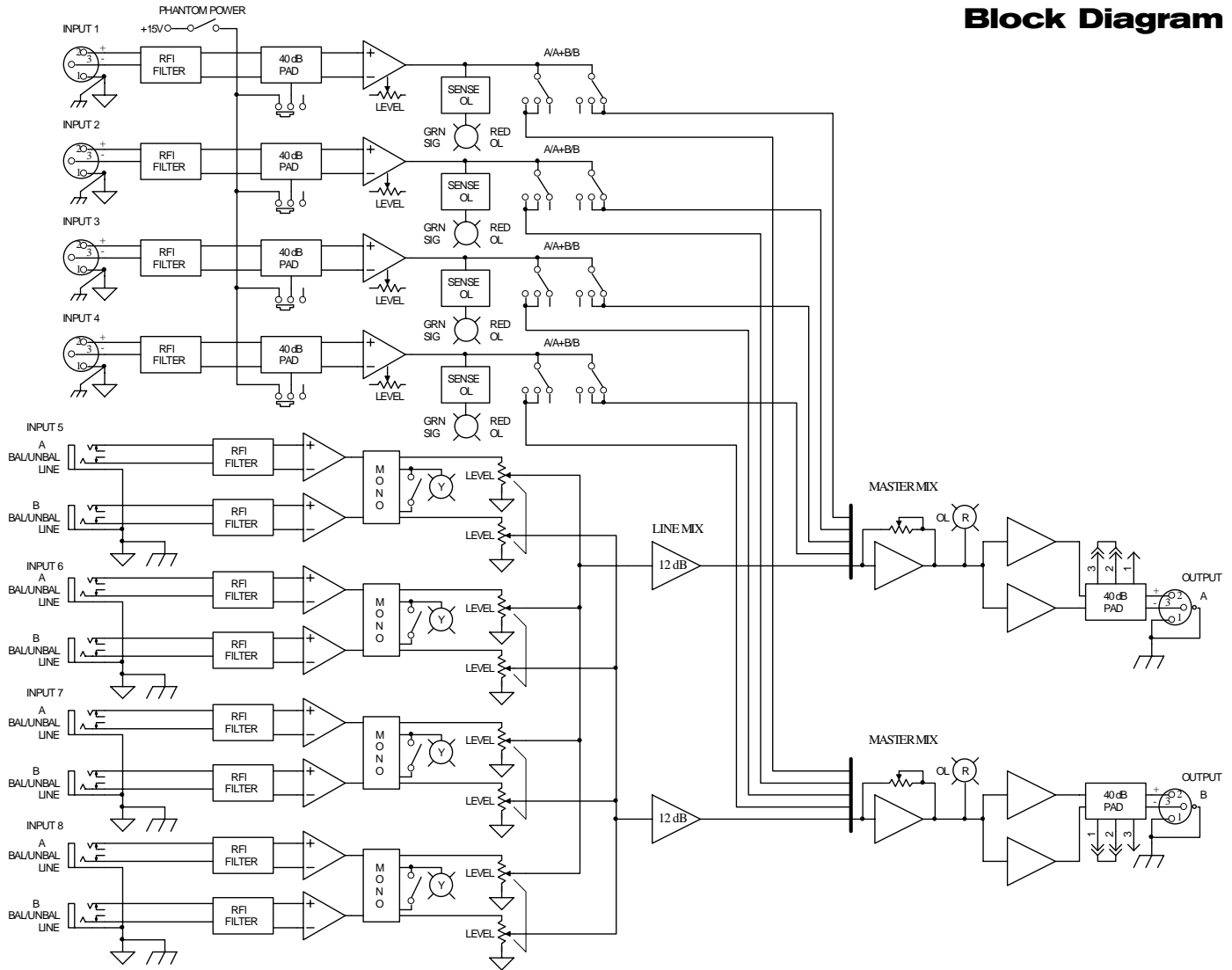

### Applications

With new features like MIC/LINE A/A+B/B ASSIGN switches, independent STEREO LINE INPUT MONO switches and additional line gain, the MLM 82a has far greater flexibility than its predecessor. The MLM 82a is now one of the most versatile mixers in its class. It is ideal for installations requiring ease of use, compact size, low cost, high performance and security. Applications include, but are not limited too, hotels, churches, conference rooms, schools

and rental sound systems. The studio-grade specifications of the MLM 82a allow many other applications such as sub-mixing, recording and post-production.

The addition of MIC/LINE A/A+B/B ASSIGN switches and independent MONO switches for each of the STEREO LINE inputs make the MLM 82a a true, dual zone capable mixer, i.e., the outputs may be thought of as two independent zones or a single stereo zone.

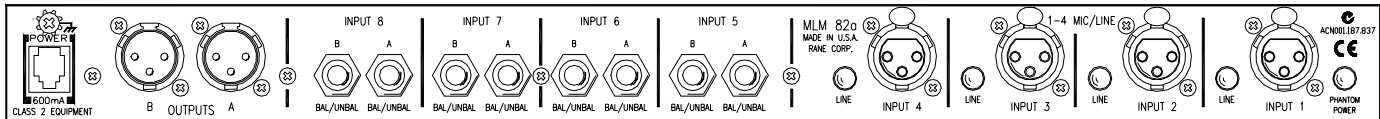
**Rear Panel****Architectural Specifications**

The mixer shall have four studio-grade mono mic/line inputs each with XLR input jack, 15 volt phantom power, line pad, A/A+B/B mix assign switch, level control and signal/overload indicator. A single switch shall make phantom power available to all four microphone inputs. Phantom power shall be removed automatically from any mic/line input set for line input. For ease of use, mic/line preamplifiers shall use a single control for input gain trim and mix level.

The mixer shall feature four stereo line inputs each with 1/4" TRS input jack, level control and pre-level control mono switch. The inputs shall provide for dual mono operation with four mono signals available for the A mix and four mono inputs available for the B mix.

A and B mix outputs shall feature overload indicators, independent A/B level controls, internally selected 40 dB pad

for microphone level output and XLR output jacks.

Security features shall include placement of the phantom power and line switches on the rear panel, recessed A/A+B/B mix assign switches, internally located pad switch for selecting line or microphone output level and recessed stereo line input mono switches with position indicators. In addition, each of the front panel level control knobs may be removed and replaced with a security plug. Four security plugs shall be provided for this purpose.

The unit shall be exempt from agency safety requirements and powered from a UL listed / CSA certified (120 VAC), or CE approved (230 VAC) remote power supply. The unit shall be constructed of cold-rolled steel and mount into a standard 19" 1U EIA rack.

*The unit shall be a Rane MLM 82a Mic/Line Mixer.*

**Available Accessories**

- SC 1.7 Single Space Security Cover

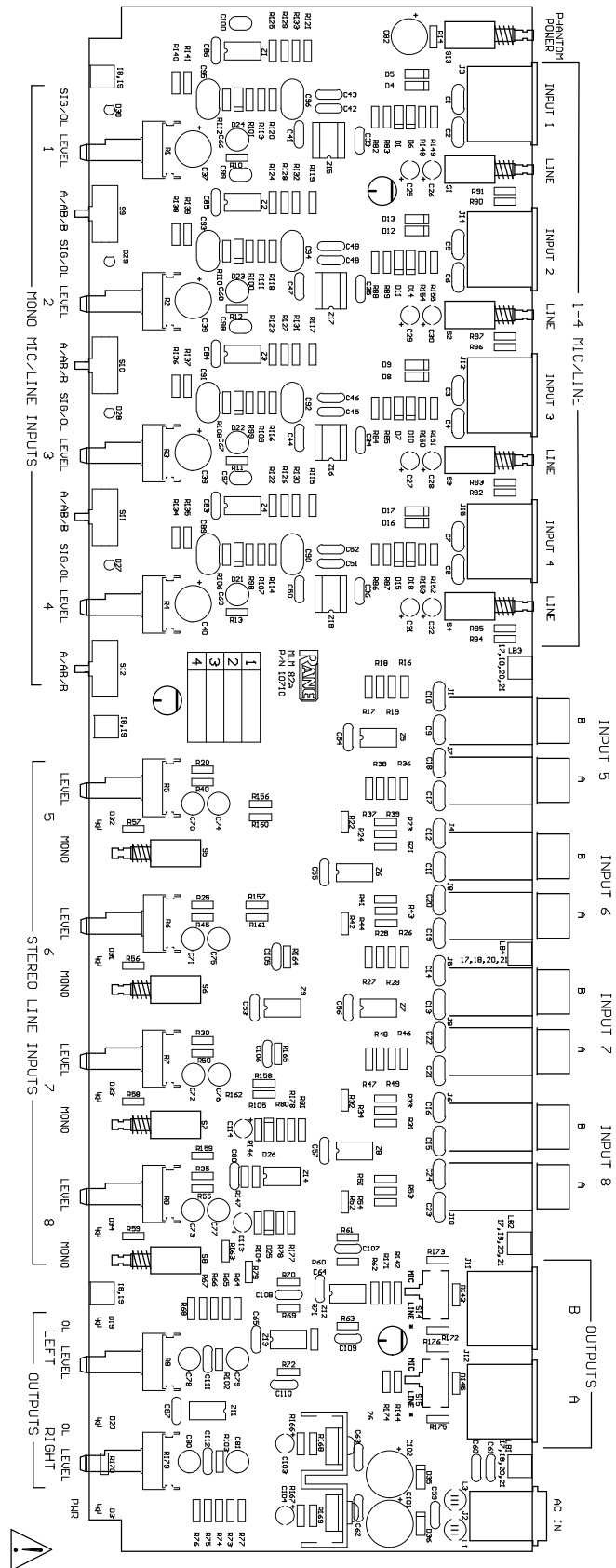

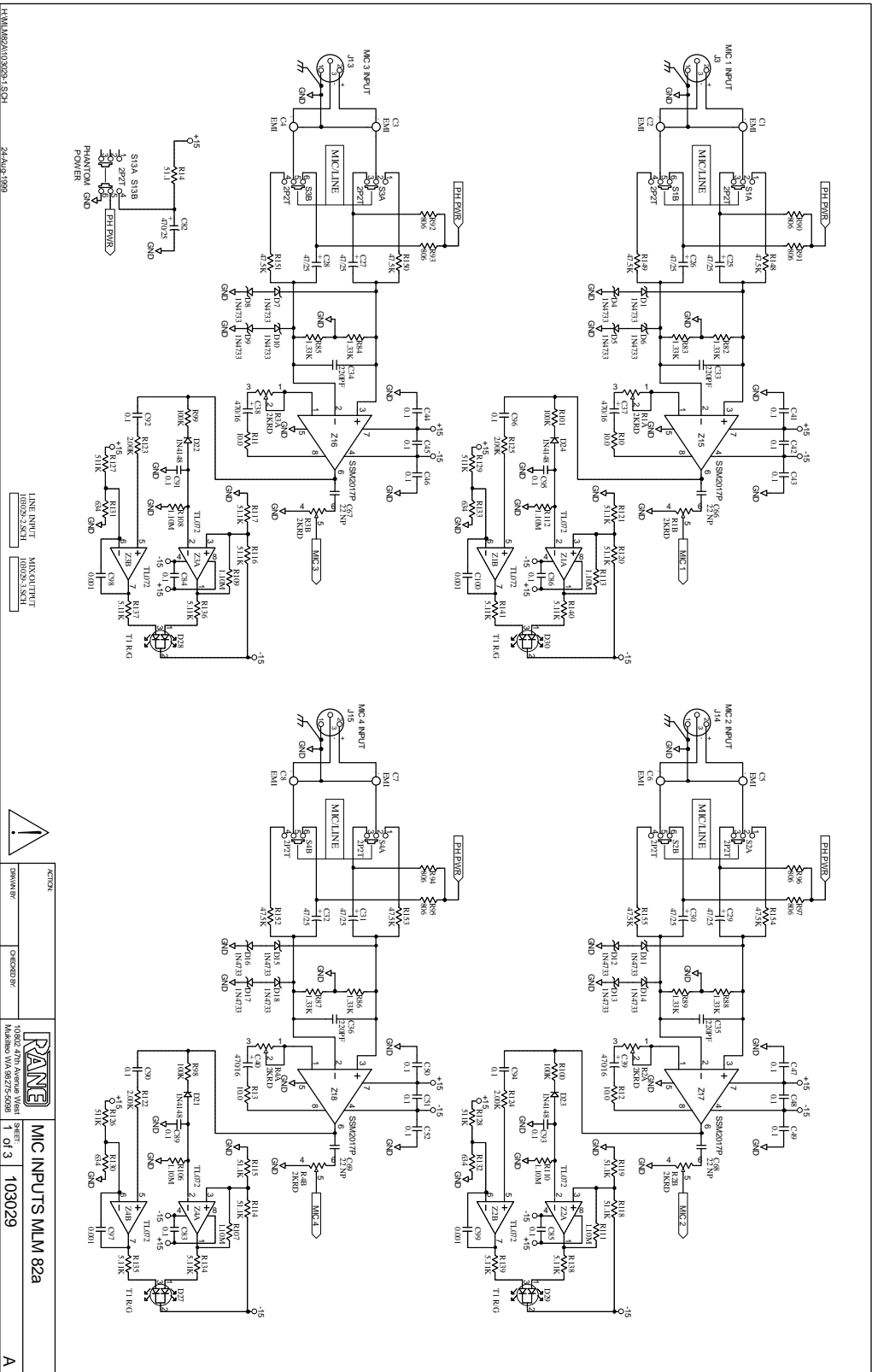

H:\M\B2A\MLM02B2A.SCH 24-MAR-1999

LINE INPUT MIC/OUTPUT  
 (0002) (5.8K)

ACTOR  
 DRAWN BY  
 CHECKER  
**PANE** MIC INPUTS MLM 82a  
 10802 47th Avenue West  
 Surrey, BC V4N 1V3  
 1 of 3 1030229  
 A

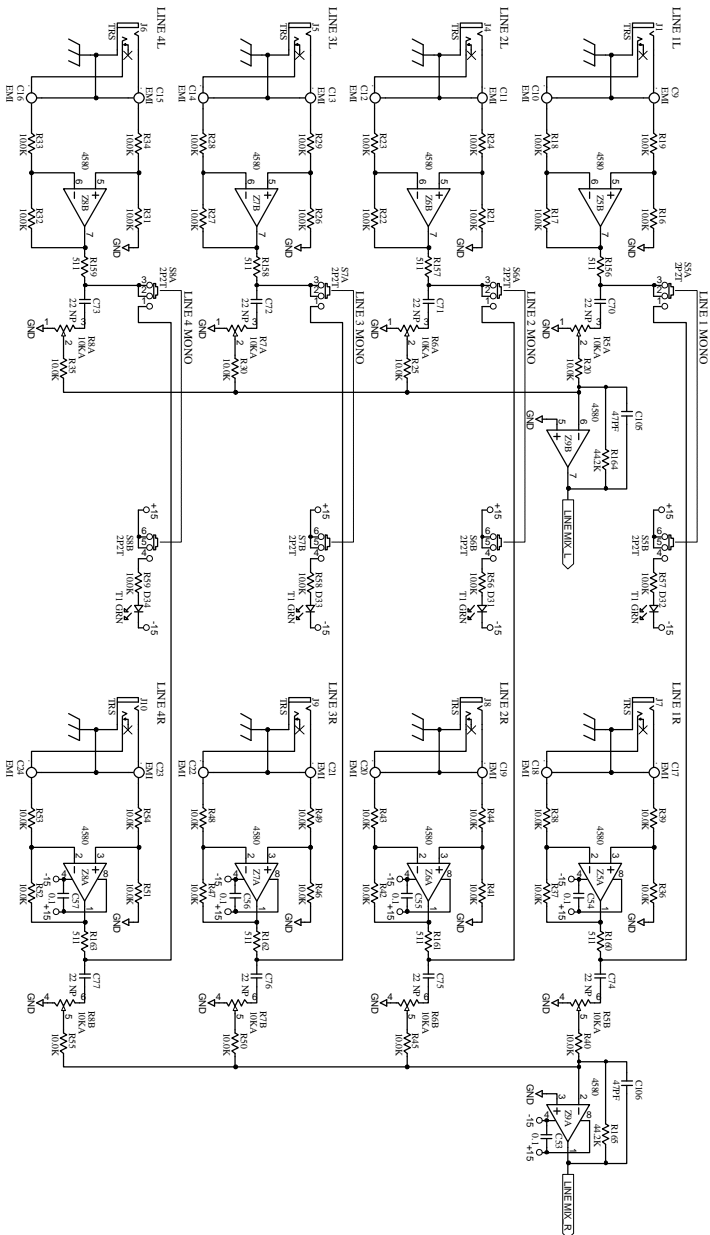

ACTOR		LINE INPUTS MILM 82a
DRAWN BY		SHEET 2 of 3
CHECKED BY	10802 47th Avenue West Maplewood WA 98275-5088	103029

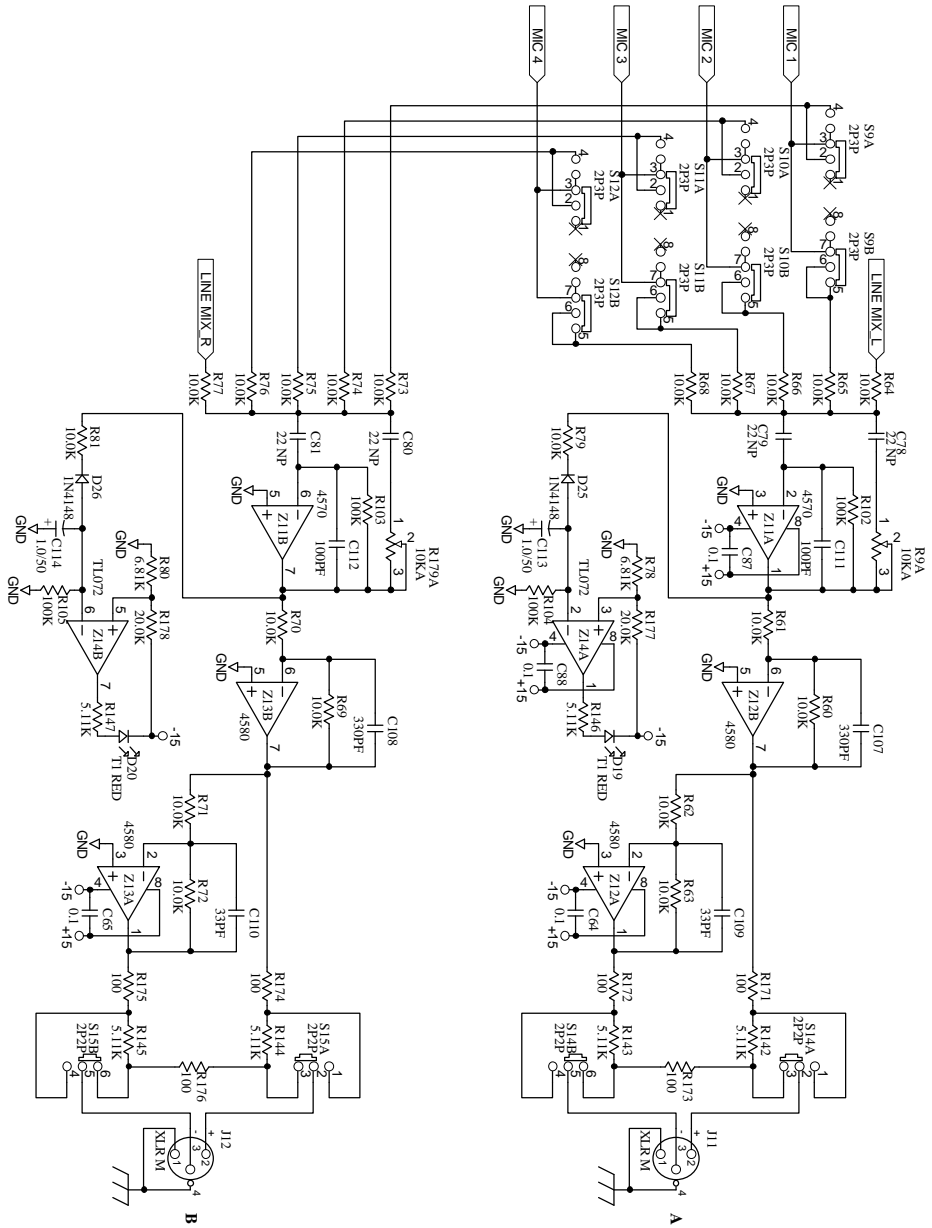

ACTION:	
DRAWN BY:	
CHECKED BY:	
<b>PANE</b>	
10902 47th Avenue West Maple Ridge VA 98275-5098	
SHEET:	3 of 3
<b>MIX/OUTPUT MLM 82a</b>	
	103029