

Printed order nr.
D GHS 30392 E

Rectifier-Diodes

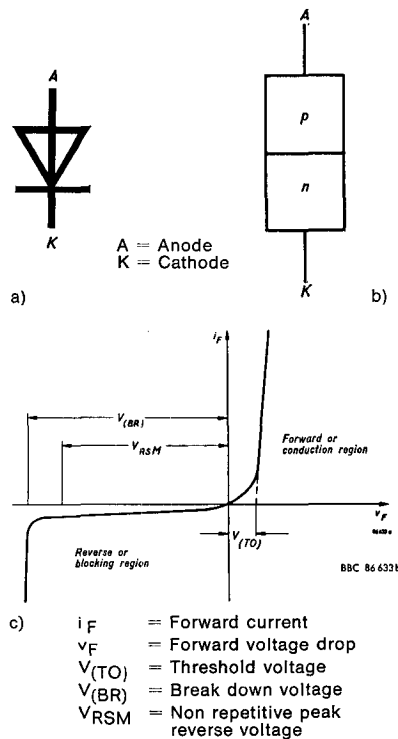

Figure 1: Diode
a) Symbol, switch sign
b) schematic constitution
c) $V_F - i_F$ characteristic

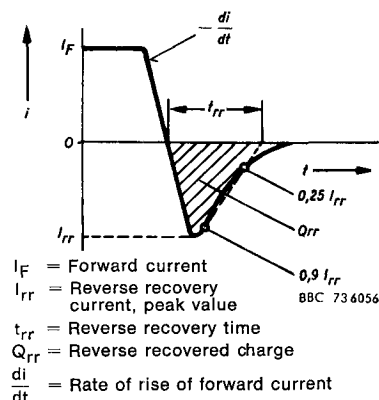

Figure 2: Current wave form during commutation of the diode from conduction state to the blocking state. (DIN 41781 page 10)

Diodes are electric devices which conduct current in one direction i.e. offer a low resistance, while blocking i.e. offering a high resistance, in the reverse direction. Silicon, proving especially efficient in the higher power range, is preferably employed for the production of semiconductor diodes.

Fig. 1 c shows the characteristic of a semiconductor diode in forward and reverse direction.

In the standard range (type code DS . .) the reverse voltage must not exceed even temporarily the non repetitive reverse voltage V_{RSM} .

Avalanche diodes of the DSA range may temporarily be exposed to voltages of the order of the break down voltage $V_{(BR)}$.

Standard-type diodes are as a rule employed in circuits with line voltage supply (50–60 Hz). For use at higher frequencies (nearly up to 1000 Hz) the dynamical properties during turn-on and turn-off should be taken into consideration.

Fast recovery diodes of the DSD range have good dynamical properties. The criterion of the "quickness" of a diode is the reverse recovery time t_{rr} indicated as time interval between the turn-off of the forward current and the instant a certain value of the reverse voltage is reached (see Fig. 2).

On changing over from the conducting to the non-conducting state the charge carrier quantity stored in the junction give rise to an excessive inverse current, the so-called recovery reverse current I_{rr} , immediately after passage of the current through zero. After the reverse recovery time has elapsed the reverse current is interrupted and finally decays to the steady state value of the inverse current. This phenomenon is known as hole storage effect and the integration of the current-time-area in reverse direction eventually gives the reverse recovered charge Q_{rr} .

Fast diodes featuring lower Q_{rr} and t_{rr} values than standard-type diodes, their reverse power losses is lower, which again results in a higher efficiency.

Type code of Brown Boveri diodes

Example: DS A I 35-14 A

DS	_____	Silicon diode (standard)
A	_____	Avalanche type
D	_____	Fast recovery type
I	_____	Inverse polarity (cathode stud mounted)
35	_____	Current rating in ampere
-14	_____	Voltage class (14 ± 1400 V)
A	_____	Modification

Glossary of terms and symbols

Terms and symbols largely correspond to the international recommendations ()

V_{RRM} = Repetitive peak reverse voltage, instantaneous value
 I_{FRMS} = Maximum permissible forward current, RMS value
 I_{FAVM} = Mean forward current, 40 to 1000 Hz of one halfsine wave
at $\vartheta_{amb} = 45^\circ \text{C}$, convection cooling and R_{thJA} , resp.
 $\vartheta_{case} = 100^\circ \text{C}$ and R_{thJC}
 I_{FSM} = Peak one cycle surge forward current, 10 ms, starting temperature $\vartheta_{(VJ)max}$
 $\int i^2 dt$ = $I^2 t$ for fusing
 I_R = Maximum reverse current at $\vartheta_{(VJ)max}$ and V_{RRM}

V_F = Forward voltage drop, maximum value at rated I_F
 $PRSM$ = Maximum reverse power surge for avalanche diodes at $\vartheta_{(VJ)max}$ and 10 μs pulse width
 $\vartheta_{(VJ)}$ = Virtual junction temperature
 $\vartheta_{(VJ)max}$ = Maximum junction temperature
 ϑ_{amb} = Ambient temperature
 ϑ_{case} = Case temperature
 R_{thJC} = Thermal resistance junction to case
 R_{thJA} = Thermal resistance junction to ambient
 t_{rr} = Reverse recovery time at 25°C
 Q_{rr} = Reverse recovered charge at 25°C

Standard and Avalanche Diodes

I_{FAVM} : ... 1 up to 11 A

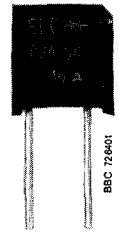

Type		V_{RRM}	I_{FRMS}	I_{FAVM}	I_{FSM}	$\int i^2 dt$	I_R	v_F (ref. i_F)	PRSM ①	ϑ (VJ) _{max} °C	R_{thJC} °C/W	R_{thJA} °C/W	Weight g	Outline Nr.
Standard	Avalanche	V	A	A	A	A ² s	mA	V	kW	°C	°C/W	°C/W		
1 N 4002	—	100	1,6	1	27	3,7	0,3	$\leq 1,1$ (1 A)	—	175	—	60	0,4	1
4003	—	200		(1,2) ② ($\vartheta_{amb} \leq 75^\circ C$)										
4004	—	400												
4005	—	600												
4006	—	800												
4007	—	1000												
DS 0,9 -04 A	—	400	5			50	12	≤ 1	$\leq 1,2$ (3 A)	1,6	150	—	38 (80) ②	0,8
-07 A	—	700												
-11 A	DSA 0,9-11 A	1100												
-14 A	-14 A	1400												
-16 A	-16 A	1600												
-18 A **	-18 A **	1800												
DS 1,2 -04 A	—	400	7	2,5	60	18	≤ 1	$\leq 1,3$ (6 A)	1,7	150	—	37 (75) ②	1,5	3
-07 A	—	700		(1,3) ②										
-11 A	DSA 1,2-11 A	1100												
-14 A	-14 A	1400												
-16 A	-16 A	1600												
-18 A **	-18 A **	1800												
DS 1,8 -04 A	—	400	7	2,5	60	18	≤ 1	$\leq 1,3$ (6 A)	1,7	150	—	33 (54) ②	2,2	4
-07 A	—	700		(1,7) ②										
-11 A	DSA 1,8-11 A	1100												
-14 A	-14 A	1400												
-16 A	-16 A	1600												
-18 A **	-18 A **	1800												
DS 2 -04 A	—	400	7	3	100	50	≤ 1	$\leq 1,25$ (7 A)	2,5	150	—	30 (75) ②	2,5	5
-07 A	—	700		(1,5) ②										
-11 A	DSA 2 -11 A	1100												
-14 A	-14 A	1400												
-16 A	-16 A	1600												
-18 A **	-18 A **	1800												
DS 6 -04 A	—	400	16	10	140	100	≤ 2	$\leq 1,6$ (30 A)	3,4	150	≤ 3	—	5	6
-07 A	—	700												
-11 A	DSA 6 -11 A	1100												
-14 A	-14 A	1400												
-16 A	-16 A	1600												
-18 A **	-18 A **	1800												
DS 9 -04 A	—	400	18	11	200	200	≤ 2	$\leq 1,4$ (36 A)	4,5	150	≤ 2	—	5	6
-07 A	—	700												
-11 A	DSA 9 -11 A	1100												
-14 A	-14 A	1400												
-16 A	-16 A	1600												
-18 A **	-18 A **	1800												

** Delivery time on request

① Only applies to avalanche diodes

② The values in brackets apply to natural air cooling, when mounted on prints

Dimensions in mm

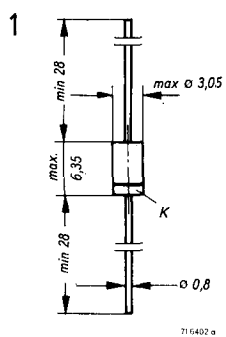

1N4002...1N4007

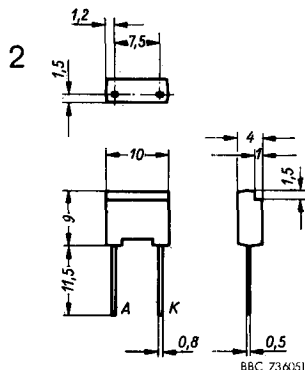

DS 0,9, DSA 0,9

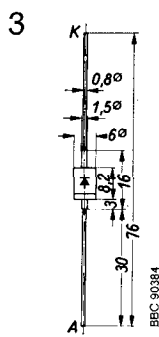

DS 1,2, DSA 1,2
DSD 1,2

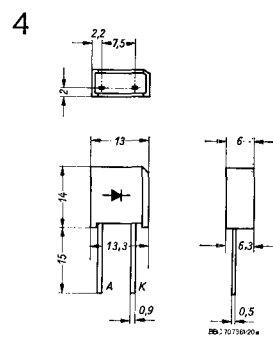

DS 1,8, DSA 1,8

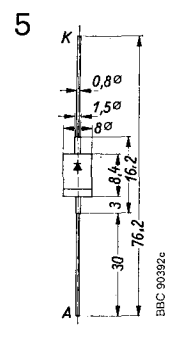

DS 2, DSA 2
DSD 2

A = Anode, K = Cathode

Standard and Avalanche Diodes

I_{FAVM} : ... 25 up to 80 A

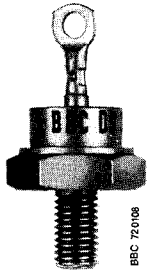

Type		V_{RRM}	I_{FRMS}	I_{FAVM}	I_{FSM}	$\int i^2 dt$	I_R	v_F (ref. i_F)	P_{RSM}	θ (VJ) _{max}	R_{thJC}	Weight	Outline
Standard	Avalanche	V	A	A	A	A*s	mA	V	kW	°C	°C/W	g	Nr.
DS 17 -02 A and DSI 17	—	200	40	25	250	310	≤ 2	≤ 1,36 (55 A)	7	180	≤ 1,5	6	7
	—	400											
	—	700											
	DSA 17 -11 A and DSA I 17	1100											
	-14 A	1400											
	-16 A*	1600											
	-18 A**	1800											
DS 22 -04 A	—	400	65	33	420	1000	≤ 4	≤ 1,8 (120 A)	9,5	150	≤ 1	15	8
	—	700											
	DSA 22 -11 A	1100											
	-14 A	1400											
	-16 A	1600											
	-18 A**	1800											
DS 25 -01 A and DSI 25	—	75	48	25	260	260	≤ 6	≤ 1,4 (90 A)	—	175	≤ 0,8	10	9
	—	150											
	—	300											
	—	450											
	—	600											
DS 35 -02 A and DSI 35	—	200	80	42	600	1800	≤ 2	≤ 1,55 (150 A)	11	150	≤ 0,9	15	10
	—	400											
	—	700											
	DSA 35 -11 A and DSA I 35	1100											
	-14 A	1400											
	-16 A*	1600											
	-18 A**	1800											
DS 42 -04 A	—	400	100	60	800	3200	≤ 4	≤ 1,7 (200 A)	18	150	≤ 0,6	33	11
	—	700											
	DSA 42 -11 A	1100											
	-14 A	1400											
	-16 A	1600											
	-18 A**	1800											
DS 80 -04 A and DSI 80	—	400	175	80	1800	16 200	≤ 6	≤ 1,4 (350 A)	28	150	≤ 0,5	130	12
	—	700											
	DSA 80 -11 A and DSA I 80	1100											
	-14 A	1400											
	-16 A*	1600											
	-18 A**	1800											

* With inverse polarity delivery time on request

** Delivery time on request

① Only applies to avalanche diodes

Dimensions in mm

A = Anode, K = Cathode

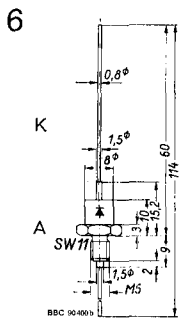

DS 6 DS 9
DSA 6 DSA 9

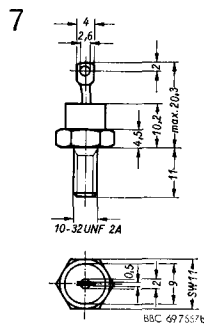

DS 17 DSI 17
DSA 17 DSA I 17
DSD 17

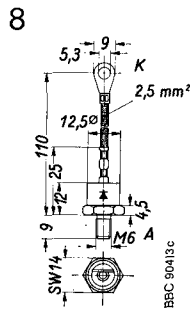

DS 22
DSA 22

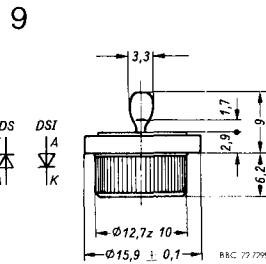

DS 25 DSI 25

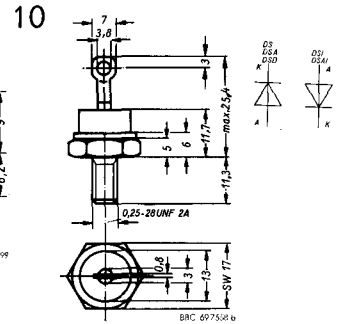

DS 35 DSI 35
DSA 35 DSA I 35
DSD 35

Standard and Avalanche Diodes

I_{FAVM} : ... 110 up to 420 A

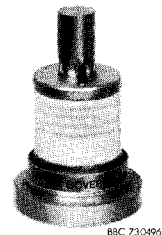

BSC 730495a

Type		V_{RRM}	I_{FRMS}	I_{FAVM}	I_{FSM}	$\int i^2 dt$	I_R	V_F (ref. I_F)	P_{RSM}	θ (V_J) _{max}	R_{thJC}	Weight	Outline
Standard	Avalanche	V	A	A	A	A ² s	mA	V	kW	°C	°C/W	g	Nr.
DS 110 -04 A and DSI 110 -07 F **	—	400	250	110	2800	39 000	≤ 6	≤ 1,4 (500 A)	35	150	≤ 0,35	130	12
-11 A	DSA 110 -11 A	700											
-14 A	and DSA I 110 -14 A	1100											
-16 A *	-16 A *	1400											
-18 A **	-18 A **	1600											
		1800											
DS 250 -04 F ** and DSI 250 -07 F **	—	400	600	250	4300	90 000	≤ 30	≤ 1,9 (1200 A)	40	140	≤ 0,12	F=340	F=13
-11 F	DSA 250 -11 F	700										L=450	L=14
-14 F	and DSA I 250 -14 F	1100											
-17 F *	-17 F *	1400											
-20 F *	-20 F *	1700											
-23 F *	-23 F *	2000											
		2300											
—	DSA 251 -26 G	2600	600	250	4300	90 000	≤ 30	≤ 2,04 (600 A)	40	140	≤ 0,08	390	15
—	-29 G	2900											
—	-32 G	3200											
—	-38 G	3800											
—	-44 G	4400											
—	-50 G	5000											
DS 400 -04 F ** -07 F **	—	400	785	400	8000	320 000	≤ 30	≤ 1,45 (1500 A)	40	140	≤ 0,08	340	13
-11 F	DSA 400 -11 F	700											
-14 F	-14 F	1100											
-17 F	-17 F	1400											
-20 F	-20 F	1700											
-23 F	-23 F	2000											
		2300											
—	DSA 401 -26 G	2600	785	300	6000	180 000	≤ 30	≤ 2,3 (1600 A)	40	140	≤ 0,08	390	15
—	-29 G	2900											
—	-32 G	3200											
—	-38 G	3800											
—	-44 G	4400											
—	-50 G	5000											
—	DSA 403-38 G	3800	—	370	7800	300 000	≤ 30	≤ 2,4 (1800 A)	50	140	≤ 0,06	G=445	G=16
—	-44 G	4400										L=715	L=17
—	-50 G	5000											
—	DSA 405-38 A	3800	—	420	7800	300 000	≤ 30	≤ 2,4 (1800 A)	50	140	≤ 0,05	250	18
—	-44 A	4400											
—	-50 A	5000											

* With inverse polarity delivery time on request

** Delivery time on request

⊕ Only applies to avalanche diodes

Dimensions in mm

A = Anode, K = Cathode

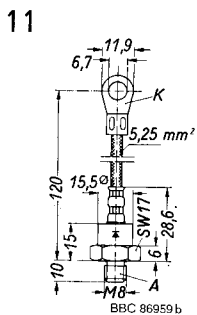

DS 42
DSA 42

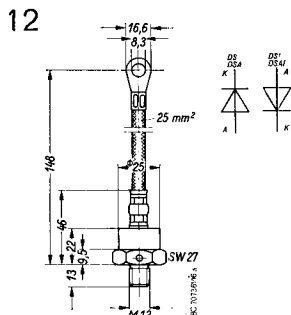

DS 80 DSI 80 DS 110 DSI 110
DSA 80 DSA I 80 DSA 110 DSA I 110

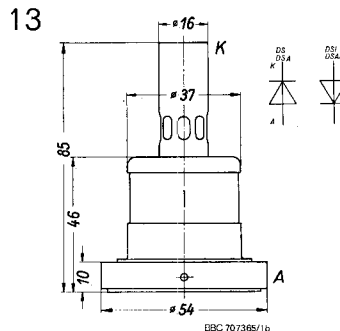

DS 250 F DSI 250 F DS 400 F
DSA 250 F DSA I 250 F DSA 400 F

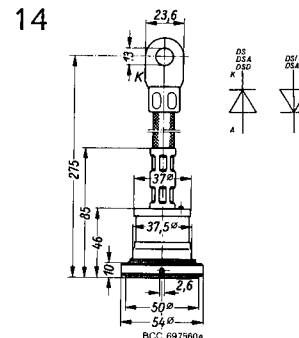

DS 250 L DSI 250 L
DSA 250 L DSA I 250 L
DSD 250

Avalanche Diodes

I_{FAVM} : ... 500 up to 840 A



Type	V_{RRM}	I_{FAVM}	I_{FSM}	$\int i^2 dt$	I_R	V_F (ref. i_F)	PRSM	$\vartheta(VJ)_{max}$	R_{thJC}	Weight	Outline
Avalanche	V	A	A	A ² s	mA	V	kW	°C	°C/W	g	Nr.
DSA 503-23 G -26 G -29 G -32 G	2300 2600 2900 3200	500	10 300	530 000	≤ 30	$\leq 1,7$ (1800 A)	50	140	$\leq 0,06$	G=445 L=715	G=16 L=17
DSA 603-11 G -14 G -17 G -20 G	1100 1400 1700 2000	600	12 600	800 000	≤ 30	$\leq 1,35$ (1800 A)	50	140	$\leq 0,06$	G=445 L=715	G=16 L=17
DSA 605-23 A -26 A -29 A -32 A	2300 2600 2900 3200	560	10 300	530 000	≤ 30	$\leq 1,7$ (1800 A)	50	140	$\leq 0,05$	250	18
DSA 607-38 A	3800	590	7 800	300 000	≤ 30	$\leq 2,4$ (1800 A)	50	140	$\leq 0,04$	200	19
DSA 705-11 A -14 A -17 A -20 A	1100 1400 1700 2000	680	12 600	800 000	≤ 30	$\leq 1,35$ (1800 A)	50	140	$\leq 0,05$	250	18
DSA 707-23 A -26 A -29 A -32 A	2300 2600 2900 3200	710	10 300	530 000	≤ 30	$\leq 1,7$ (1800 A)	50	140	$\leq 0,04$	200	19
DSA 807-11 A -14 A -17 A -20 A	1100 1400 1700 2000	840	12 600	800 000	≤ 30	$\leq 1,35$ (1800 A)	50	140	$\leq 0,04$	200	19

Dimensions in mm

A = Anode, K = Cathode

15

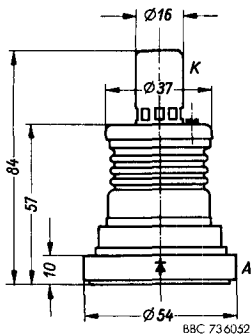

DSA 251 G
DSA 401 G

16

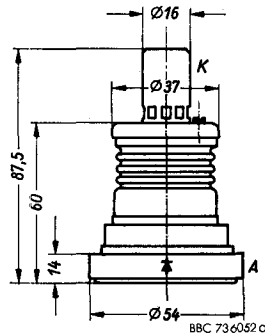

DSA 403 G
DSA 503 G
DSA 603 G

17

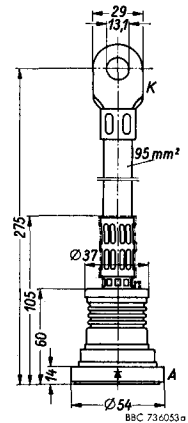

DSA 403 L
DSA 503 L
DSA 603 L

Fast Recovery Diodes

I_{FAVM} : ... 1 up to 350 A

NEW

Preliminary data

Type	V_{RRM} V	I_{FAVM} A	I_{FSM} A	$\int i^2 dt$ A ² s	I_R mA	V_F (ref. I_F) V	t_{rr} μ s	$\left. \begin{matrix} \text{at } I_F \\ \text{and} \\ di/dt \end{matrix} \right\} Q_{rr}$ μ As	$\vartheta(VJ)_{max}$ °C	R_{thJA} °C/W	R_{thJC} °C/W	Weight g	Outline Nr.	
DSD 1,2-01 A -02 A -04 A -06 A	100 200 400 600	1	60	18	≤ 1	$\leq 1,3$ (3 A)	$\leq 0,3$	1 A 10 A/ μ s	0,3	150	75	—	1,5	3
DSD 2 -01 A -02 A -04 A -06 A -08 A -10 A	100 200 400 600 800 1000	1,2	100	50	≤ 1	$\leq 1,3$ (3,5 A)	$\leq 0,3$ $\leq 0,5$	1,2 A 10 A/ μ s	0,3 0,75	150	75	—	2,5	5
DSD 17 -01 A -02 A -04 A -07 A -11 A -14 A	100 200 400 700 1100 1400	16	250	310	≤ 2	$\leq 1,7$ (50 A)	$\leq 0,3$ $\leq 0,5$ ≤ 1	16 A 50 A/ μ s	0,75 2 7,5	150	—	$\leq 1,7$	6	7
DSD 35 -01 A -02 A -04 A -07 A -11 A -14 A	100 200 400 700 1100 1400	28	400	800	≤ 3	$\leq 1,65$ (85 A)	$\leq 0,3$ $\leq 0,5$ ≤ 1	28 A 50 A/ μ s	1,5 4 15	150	—	≤ 1	15	10
DSD 250-08 A* -10 A -12 A -14 A -16 A*	800 1000 1200 1400 1600	250	3800	72 000	≤ 80	$\leq 1,6$ (500 A)	—	500 A 25 A/ μ s	100	150	—	$\leq 0,12$	550	14
DSD 304-06 A -08 A -10 A -11 A -12 A	600 800 1000 1100 1200	350 ($\vartheta_C = 65^\circ C$)	2200	24 000	≤ 16	$\leq 1,3$ (400 A) $\vartheta(VJ) = 70^\circ C$	—	300 A 50 A/ μ s	25	125	—	$\leq 0,09$	52	20

* on request

Dimensions in mm

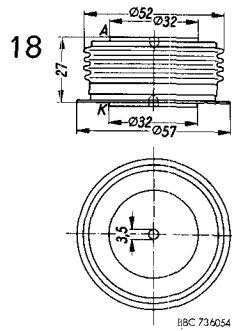

DSA 405
DSA 605
DSA 705

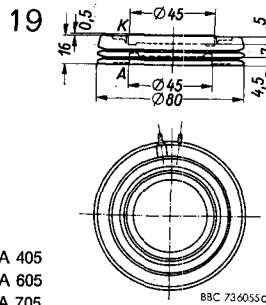

BBC 736053a

A = Anode, K = Cathode

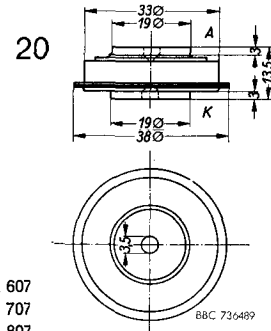

DSA 607
DSA 707
DSA 807

DSD 304

Detailed data sheets with diagrams covering the whole range of devices are available.

Write for further informations to:

BBC
BROWN BOVERI

BROWN, BOVERI & CIE
AKTIENGESELLSCHAFT
MANNHEIM

Geschäftsbereich Halbleiter und Stromrichter
D-6840 Lampertheim · Postfach 200
Tel. (0 62 06) 50 31 · Telex 04-65 727

Klassifikations-Nr. 0701/541
GHS 1617 E

Printed in the Federal Republic of Germany

Submitted by: