



MICROWAVE OVEN

M1774

SERVICE Manual

MICROWAVE OVEN

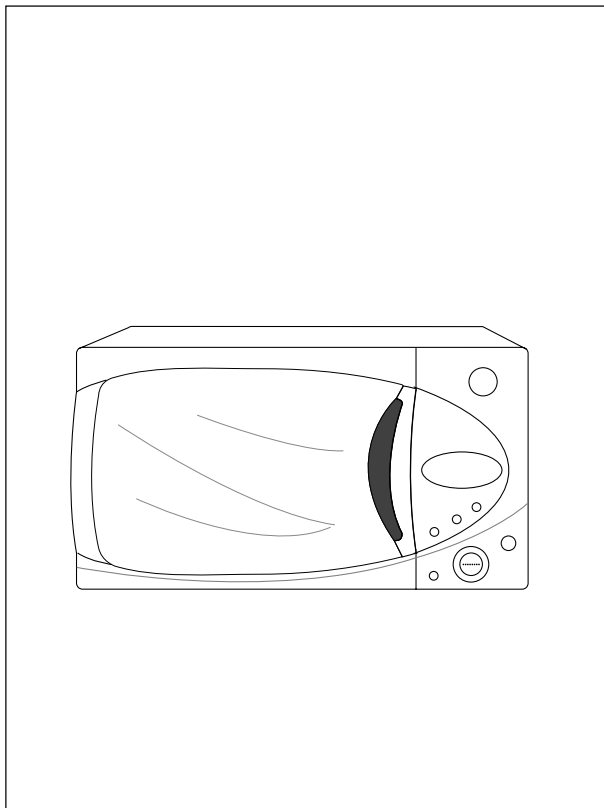

CONTENTS

1. Precaution
2. Specifications
3. Operating Instructions
4. Disassembly and Reassembly
5. Alignment and Adjustments
6. Troubleshooting
7. Exploded Views and Parts List
8. PCB Diagrams
9. Schematic Diagrams

1. Precaution

Follow these special safety precautions. Although the microwave oven is completely safe during ordinary use, repair work can be extremely hazardous due to possible exposure to microwave radiation, as well as potentially lethal high voltages and currents.



1-1 Safety precautions (⚠)

1. All repairs should be done in accordance with the procedures described in this manual. This product complies with Federal Performance Standard 21 CFR Subchapter J (DHHS).
2. Microwave emission check should be performed prior to servicing if the oven is operative.
3. If the oven operates with the door open : Instruct the user not to operate the oven and contact the manufacturer and the center for devices and radiological health immediately.
4. Notify the Central Service Center if the microwave leakage exceeds 5 mW/cm²
5. Check all grounds.
6. Do not power the MWO from a "2-prong" AC cord. Be sure that all of the built-in protective devices are replaced. Restore any missing protective shields.
7. When reinstalling the chassis and its assemblies, be sure to restore all protective devices, including: nonmetallic control knobs and compartment covers.
8. Make sure that there are no cabinet openings through which people--particularly children--might insert objects and contact dangerous voltages. Examples: Lamp hole, ventilation slots.
9. Inform the manufacturer of any oven found to have emission in excess of 5 mW/cm², Make repairs to bring the unit into compliance at no cost to owner and try to determine cause.
Instruct owner not to use oven until it has been brought into compliance.
10. Service technicians should remove their watches while repairing an MWO.
11. To avoid any possible radiation hazard, replace parts in accordance with the wiring diagram. Also, use only the exact replacements for the following parts: Primary and secondary interlock switches, interlock monitor switch.
12. If the fuse is blown by the Interlock Monitor Switch: Replace all of the following at the same time: Primary and secondary switches, as well as the Interlock Monitor Switch. The correct adjustment of these switches is described elsewhere in this manual. Make sure that the fuse has the correct rating for the particular model being repaired.
13. Design Alteration Warning:
Use exact replacement parts only, i.e., only those that are specified in the drawings and parts lists of this manual. This is especially important for the Interlock switches, described above. Never alter or add to the mechanical or electrical design of the MWO. Any design changes or additions will void the manufacturer's warranty.10. Always unplug the unit's AC power cord from the AC power source before attempting to remove or reinstall any component or assembly.
14. Never defeat any of the B+ voltage interlocks. Do not apply AC power to the unit (or any of its assemblies) unless all solid-state heat sinks are correctly installed.
15. Some semiconductor ("solid state") devices are easily damaged by static electricity. Such components are called Electrostatically Sensitive Devices (ESDs). Examples include integrated circuits and field-effect transistors.

Immediately before handling any semiconductor components or assemblies, drain the electrostatic charge from your body by touching a known earth ground.
16. Always connect a test instrument's ground lead to the instrument chassis ground *before* connecting the positive lead; always remove the instrument's ground lead last.

CENTRAL SERVICE CENTER

1-2 Special Servicing Precautions (Continued)

17. When checking the continuity of the switches or transformer, always make sure that the power is OFF, and one of the lead wires is disconnected.
18. Components that are critical for safety are indicated in the circuit diagram by shading,  or .
19. Use replacement components that have the same ratings, especially for flame resistance and dielectric strength specifications. A replacement part that does not have the same safety characteristics as the original might create shock, fire or other hazards.

1-3 Special High Voltage Precautions

1. High Voltage Warning
Do not attempt to measure any of the high voltages--this includes the filament voltage of the magnetron. High voltage is present during any cook cycle.

Before touching any components or wiring, always unplug the oven and discharge the high voltage capacitor (See Figure 1-1)
2. The high-voltage capacitor remains charged about 30 seconds after disconnection. Short the negative terminal of the high-voltage capacitor to the oven chassis. (Use a screwdriver.)
3. High voltage is maintained within specified limits by close-tolerance, safety-related components and adjustments. If the high voltage exceeds the specified limits, check each of the special components.

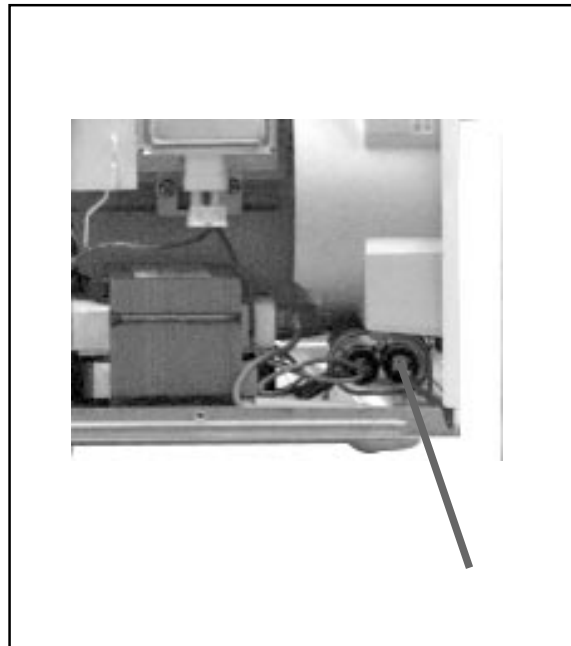

Fig. 1-1. Discharging the High Voltage Capacitor

2. Specifications

2-1 Table of Specifications

TIMER	99 MINUTES
POWER SOURCE	230V 50Hz, AC
POWER CONSUMPTION	MICROWAVE : 1,250W
OUTPUT POWER	FROM 100 TO 850W (IEC-705 TEST PROCEDURE)
OPERATING FREQUENCY	2,450MHz
MAGNETRON	OM75SH(31)
COOLING METHOD	COOLING FAN MOTOR
OUTSIDE DIMENSIONS	489(W) x 275(H) x 370(D)

2-2 Comparison Chart

AUTO REHEAT	0
AUTO COOK	0
POWER LEVEL	0
TIME SETTING AND WEIGHT	0
AUTO DEFROST	0
DEODORIZATION	0

3. Operating Instructions

3-1 Control Panel

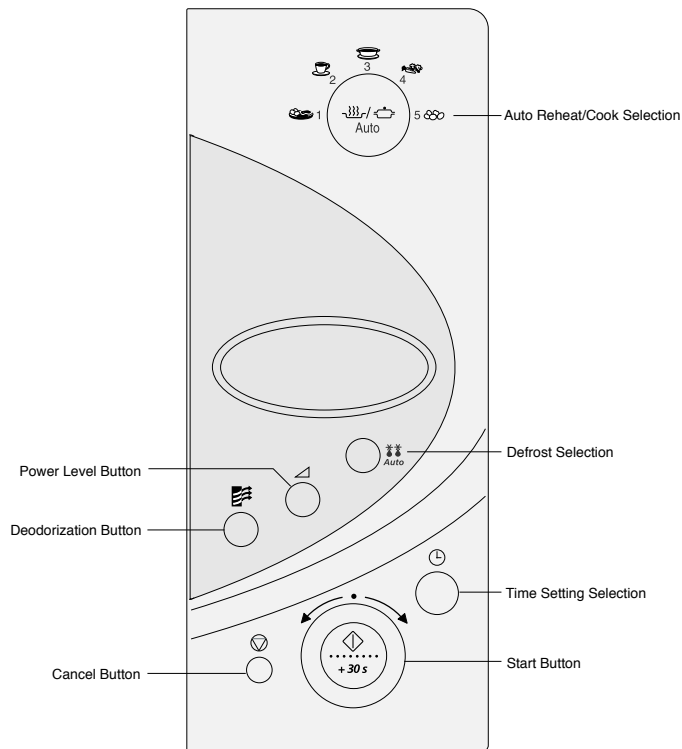

3-2 Features & External Views

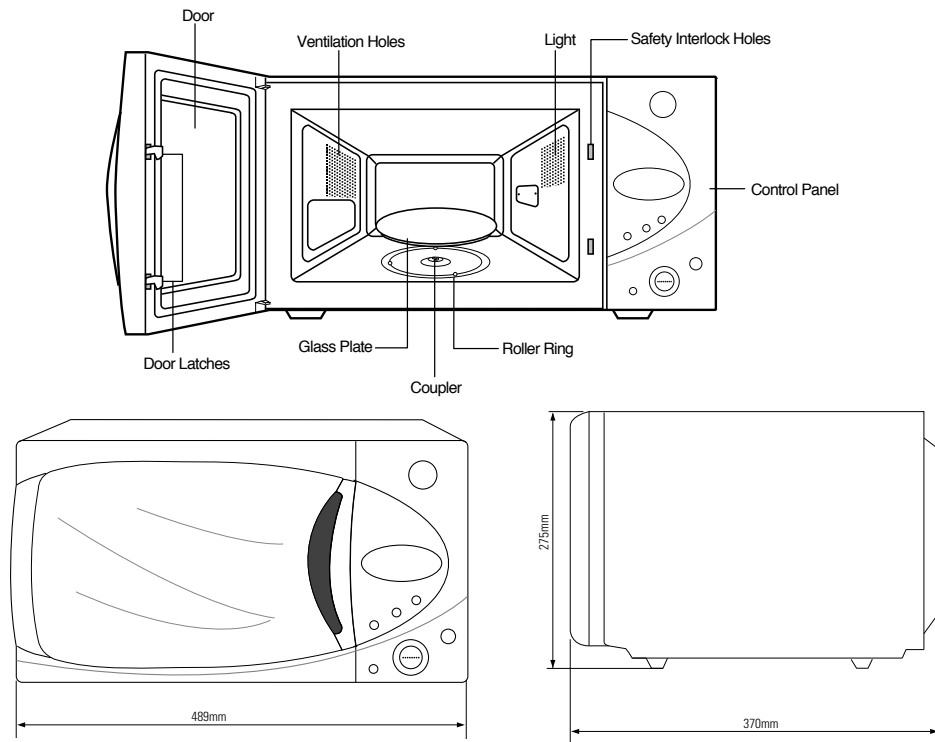

4. Disassembly and Reassembly

4-1 Replacement of Magnetron, Motor Assembly and Lamp

Remove the magnetron including the shield case, permanent magnet, choke coils and capacitors (all of which are contained in one assembly).

1. Disconnect all lead wires from the magnetron and lamp.
2. Remove a screw securing the magnetron supporter.
3. Remove the magnetron supporter.
4. Remove the air cover.
5. Remove screws securing the magnetron to the wave guide.
6. Take out the magnetron very carefully.
7. Remove nuts from the back panel.
8. Take out the fan motor.
9. Remove the oven lamp by rotating to pull out from hole of air cover.

NOTE1: When removing the magnetron, make sure that its antenna does not hit any adjacent parts, or it may be damaged.

NOTE2: When replacing the magnetron, be sure to remount the magnetron gasket in the correct position and make sure the gasket is in good condition.

4-2 Replacement of High Voltage Transformer

1. Discharge the high voltage capacitor.
2. Disconnect all the leads.
3. Remove the mounting bolts.
4. Reconnect the leads correctly and firmly.

PRECAUTION

Servicemen should remove their watches whenever working close to or replacing the magnetron.

PRECAUTION

There exists HIGH VOLTAGE ELECTRICITY with high current capabilities in the circuits of the HIGH VOLTAGE TRANSFORMER secondary and filament terminals. It is extremely dangerous to work on or near these circuits with the oven energized. DO NOT measure the voltage in the high voltage circuit including filament voltage of magnetron.

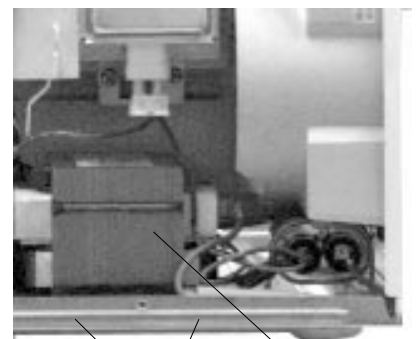

Screws

H. V. Trans

4-3 Replacement of Door Assembly

4-3-1 Removal of Door Assembly

Remove hex bolts securing the upper hinge and lower hinge. Then remove the door assembly.

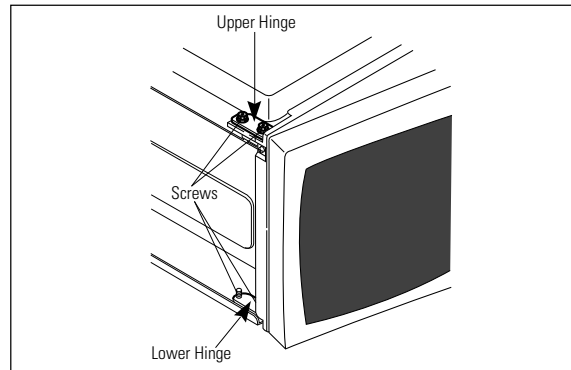

4-3-2 Removal of Door "C"

Insert flat screwdriver into the gap between Door "E" and Door "C" to remove Door "C". Be careful when handling Door "C" because it is fragile.

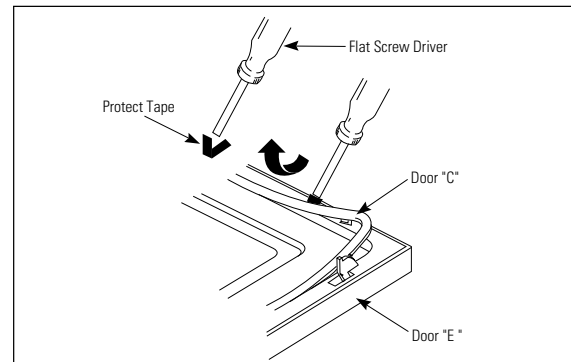

4-3-3 Removal of Door "E"

Following the procedure as shown in the figure, insert and bend a thin metal plate between Door "E" and Door "A" until you hear the 'tick' sound.

=> Insertion depth of the thin metal plate should be 0.5mm or less.

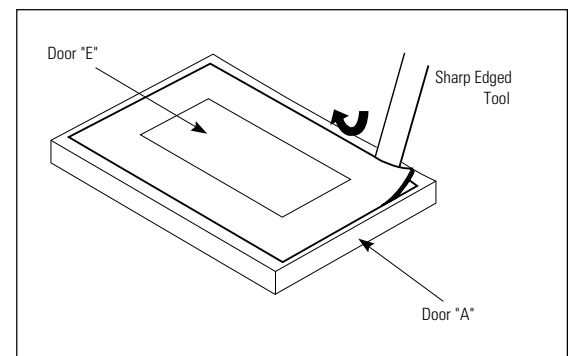

4-3-4 Removal of Key Door & Spring

Remove pin hinge from Door "E"
Detach spring from Door "E" and key door.

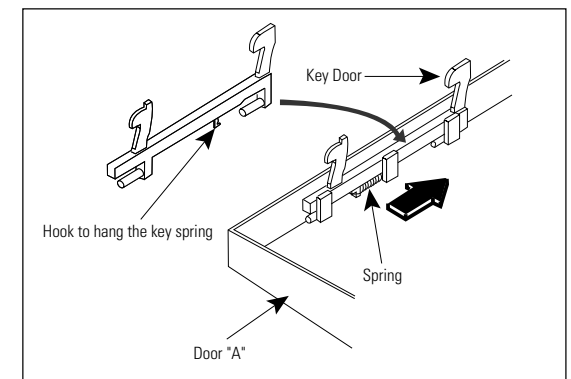

4-3-5 Reassembly Test

After replacement of the defective component parts of the door, reassemble it and follow the instructions below for proper installation and adjustment so as to prevent an excessive microwave leakage.

1. When mounting the door to the oven, be sure to adjust the door parallel to the bottom line of the oven face plate by moving the upper hinge and lower hinge in the direction necessary for proper alignment.
2. Adjust so that the door has no play between the inner door surface and oven front surface. If the door assembly is not mounted properly, microwave energy may leak from the space between the door and oven.
3. Do the microwave leakage test.

4-4 Replacement of Fuse

1. Disconnect the oven from the power source.
2. Remove the 10A fuse in the fuse holder.
3. When replacing the 10A fuse, be sure to use an exact replacement part. If new 10A fuse blows out again after replacement, check the primary interlock switch, door sensing switch and interlock monitor switch.
4. When the above three switches operate properly, check if any other part such as the control circuit board, blower motor or high voltage transformer is defective.

4-5 Replacement of Drive Motor

1. Take out the glass tray, guide roller and coupler from cavity.
2. Turn the oven upside down to replace the drive motor.
3. Remove a screw securing the drive motor cover.
4. Disconnect all the lead wires from the drive motor.
5. Remove screws securing the drive motor to the cavity.
6. Remove the drive motor.
7. When replacing the drive motor, be sure to remount it in the correct position.
8. Connect all the leads to the drive motor.
9. Screw the drive motor cover to the base plate with a screw driver.
10. Remount the coupler in the correct position.

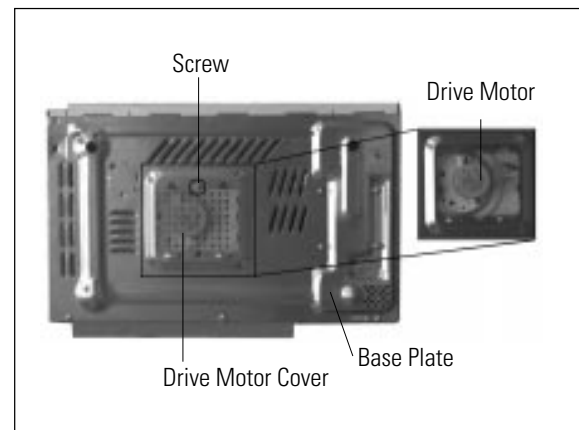

4-6 Replacement of Control Circuit Board

4-6-1 Removal of Ass'y Control Box

1. Be sure to ground any static electric charge in your body and never touch the touch control circuitry.
2. Disconnect the connectors from the control circuit board.
3. Remove screws securing the control box assembly.
4. Remove the screw securing the ground tail of the keyboard.

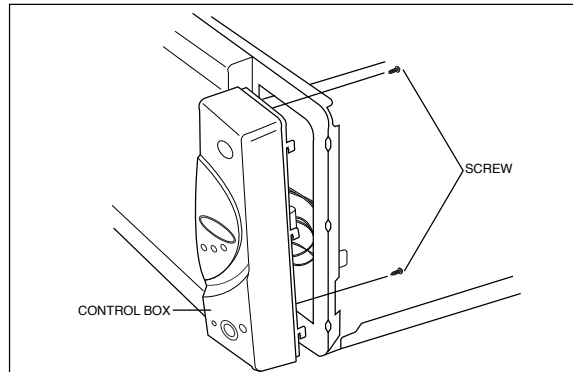

4-6-2 Remonal of Ass'y P.C.B

1. Pull the lever end of the plastic fastener and remove the Flexible Printed Circuit(FPC) of membrane panel.
2. Remove screws securing the control circuit board.
3. Lift up the control circuit board from the Ass'y control box.
4. When reconnecting the FPC connector, make sure that the holes on the connector are properly engaged with the hooks on the Plastic Fastener.

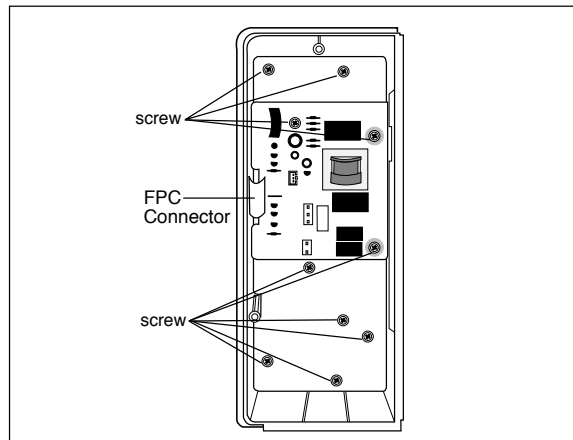

5. Alignment and Adjustments

PRECAUTION

1. High voltage is present at the high voltage terminals during any cook cycle.
2. It is neither necessary nor advisable to attempt measurement of the high voltage.
3. Before touching any oven components or wiring, always unplug the oven from its power source and discharge the high voltage capacitor.

5-1 High Voltage Transformer

1. Remove connectors from the transformer terminals and check continuity.
2. Normal resistance readings are as follows:

Secondary	Approx. 114 Ω
Filament	Approx. 0 Ω
Primary	Approx. 1.47 Ω

(Room temperature = 20°C)

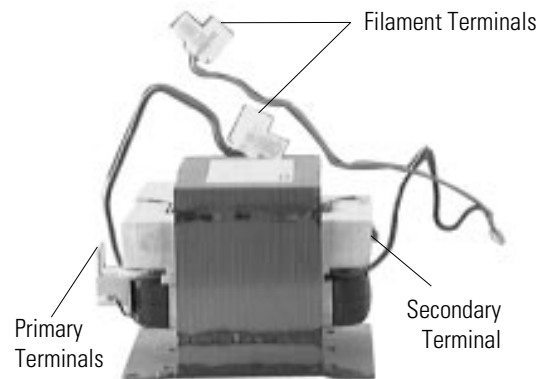

5-2 Low Voltage Transformer

1. The low voltage transformer is located on the control circuit board.
2. Remove the low voltage transformer from the PCB Ass'y and check continuity.
3. Normal resistor reading is shown in the table.

Terminals	Resistance
1~2(Input)	1,000 Ω
3~4(Output 2.9V)	3.947 Ω
5~6(Output 13V)	2.117 Ω

5-3 Magnetron

1. Continuity checks can indicate only an open filament or a shorted magnetron. To diagnose an open filament or shorted magnetron :
2. Isolate the magnetron from the circuit by disconnecting its leads.
3. A continuity check across the magnetron filament terminals should indicate one ohm or less.
4. A continuity check between each filament terminal and magnetron case should read open.

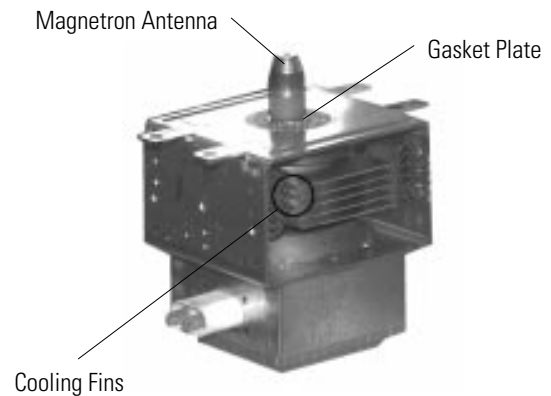

5-4 High Voltage Capacitor

1. Check continuity of the capacitor with the meter set at the highest resistance scale.
2. Once the capacitor is charged, a normal capacitor shows continuity for a short time, and then indicates $9M\Omega$.
3. A shorted capacitor will show continuous continuity.
4. An open capacitor will show constant $9M\Omega$.
5. Resistance between each terminal and chassis should read infinite.

5-5 High Voltage Diode

1. Isolate the diode from the circuit by disconnecting its leads.
2. With the ohm-meter set at the highest resistance scale, measure across the diode terminals. Reverse the meter leads and read the resistance. A meter with 6V, 9V or higher voltage batteries should be used to check the front-to back resistance of the diode (otherwise an infinite resistance may be read in both directions). The resistance of a normal diode will be infinite in one direction and several hundred $K\Omega$ in the other direction.

5-6 Main Relay and Power Control Relay

1. The relays are located on the PCB Ass'y. Isolate them from the main circuit by disconnecting the leads.
2. Operate the microwave oven with a water load in the oven. Set the power level set to high.
3. Check continuity between terminals of the relays after the start pad is pressed.

5-7 Adjustment of Primary Switch, Door Sensing Switch and Monitor Switch

Precaution

For continued protection against radiation hazard, replace parts in accordance with the wiring diagram and be sure to use the correct part number for the following switches: Primary and secondary interlock switches, and the interlock monitor switch (replace all together). Then follow the adjustment procedures below. After repair and adjustment, be sure to check the continuity of all interlock switches and the interlock monitor switch.

1. When mounting Primary switch and Interlock Monitor switch to Latch Body, consult the figure.
2. No specific adjustment during installation of Primary switch and Monitor switch to the latch body is necessary.
3. When mounting the Latch Body to the oven assembly, adjust the Latch Body by moving it so that the oven door will not have any play in it. Check for play in the door by pulling the door assembly. Make sure that the latch keys move smoothly after adjustment is completed. Completely tighten the screws holding the Latch Body to the oven assembly.
4. Reconnect to Monitor switch and check the continuity of the monitor circuit and all latch switches again by following the components test procedures.
5. Confirm that the gap between the switch housing and the switch actuator is no more than 0.5mm when door is closed.

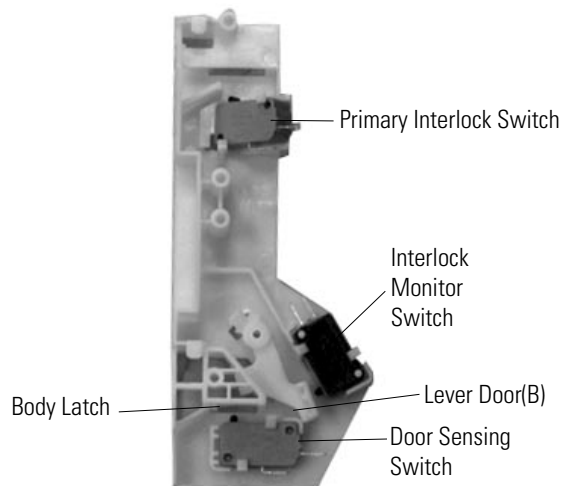

	Door Open	Door Closed
Primary switch	∞	0
Monitor switch (COM-NC)	0	∞
Monitor switch (COM-NO)	∞	0
Door Sensing S/W	∞	0

5-8 Output Power of Magnetron

CAUTION MICROWAVE RADIATION

PERSONNEL SHOULD NOT ALLOW EXPOSURE TO MICROWAVE RADIATION FROM MICROWAVE GENERATOR OR OTHER PARTS CONDUCTING MICROWAVE ENERGY.

The output power of the magnetron can be measured by performing a water temperature rise test.

Equipment needed :

- * Two 1-liter cylindrical borosilicate glass vessel (Outside diameter 190 mm)
- * One glass thermometer with mercury column

NOTE: Check line voltage under load. Low voltage will lower the magnetron output. Make all temperature and time tests with accurate equipment.

1. Fill the one liter glass vessel with water.
2. Stir water in glass vessel with thermometer, and record glass vessel's temperature ("T1", 10±1°C).
3. After moving the water into another glass vessel, place it in the center of the cooking tray. Set the oven to high power and operate for 52 seconds exactly. (3 seconds included as a holding time of magnetron oscillation:)
4. When heating is finished, stir the water again with the thermometer and measure the temperature ("T2").
5. Subtract T1 from T2. This will give you the water temperature rise. (ΔT)
6. The output power is obtained by the following formula;

$$\text{Output Power} = \frac{4.187 \times 1000 \times \Delta T + 0.55 \text{ Wb} (T_2 - T_0)}{49}$$

49 : Heating Time (sec)
 4.187 : Coefficient for Water
 1000 : Water (cc)
 ΔT : Temperature Rise (T2-T1)
 T₀ : Room Temperature
 Wb : Beaker Weight

7. Normal temperature rise for this model is 9°C to 11°C at 'HIGH'.

NOTE 1 : Variations or errors in the test procedure will cause a variance in the temperature rise. Additional power test should be made if temperature rise is marginal.

NOTE 2 : Output power in watts is computed by multiplying the temperature rise (step E) by a factor of 91 times the of centigrade temperature.

5-9 Procedure for Measurement of Microwave Energy Leakage

- 1) Pour 275 ± 15 cc of $20 \pm 5^\circ\text{C}$ ($68 \pm 9^\circ\text{F}$) water in a beaker which is graduated to 600cc, and place the beaker in the center of the oven.
- 2) Start to operate the oven and measure the leakage by using a microwave energy survey meter.
- 3) Set survey meter with dual ranges to 2,450MHz.
- 4) When measuring the leakage, always use the 2 inch spacer cone with the probe. Hold the probe perpendicular to the cabinet door. Place the spacer cone of the probe on the door and/or cabinet door seam and move along the seam, the door viewing window and the exhaust openings moving the probe in a clockwise direction at a rate of 1 inch/sec. If the leakage testing of the cabinet door seam is taken near a corner of the door, keep the probe perpendicular to the areas making sure that the probe end at the base of the cone does not get closer than 2 inches to any metal. If it gets closer than 2 inches, erroneous readings may result.
- 5) Measured leakage must be less than $4\text{mW}/\text{cm}^2$, after repair or adjustment.

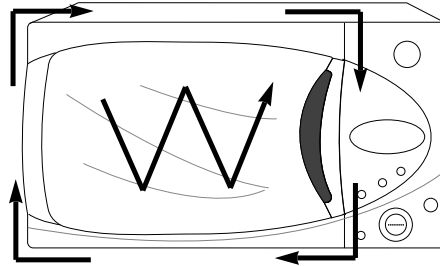

Maximum allowable leakage is $5\text{mW}/\text{cm}^2$.
 $4\text{mW}/\text{cm}^2$ is used to allow for measurement and meter accuracy

5-10 Check for Microwave Leakage

1. Remove the outer panel.
2. Pour 275 ± 15 cc of $20 \pm 5^\circ\text{C}$ ($68 \pm 9^\circ\text{F}$) water in a beaker which is graduated to 600cc, and place the beaker in the center of the oven.
3. Start the oven at the highest power level.
4. Set survey meter dual ranges to 2,450MHz.
5. Using the survey meter and spacer cone as described above, measure around the opening of magnetron, the surface of the air guide and the surface of the wave guide as shown in the following photo. (but avoid the high voltage components.) The reading should be less than $4\text{mW}/\text{cm}^2$.

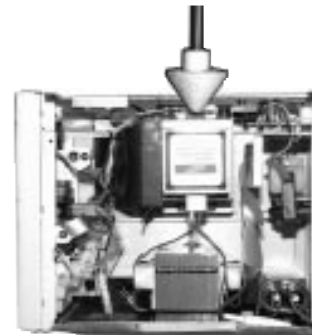

5-11 Note on Measurement

- 1) Do not exceed the limited scale.
- 2) The test probe must be held on the grip of the handle, otherwise a false reading may result when the operator's hand is between the handle and the probe.
- 3) When high leakage is suspected, do not move the probe horizontally along the oven surface; this may cause damage to the probe.
- 4) Follow the recommendation of the manufacturer of the microwave energy survey meter.

5-12 Leakage Measuring Procedure

- 5-13-1 Record keeping and notification after measurement
- 1) After adjustment and repair of a radiation preventing device, make a repair record for the measured values, and keep the data.
 - 2) If the radiation leakage is more than $4\text{mW}/\text{cm}^2$ after determining that all parts are in good condition, functioning properly and the identical parts are replaced as listed in this manual notify that fact to ;

CENTRAL SERVICE CENTER

- 5-13-2 At least once a year have the microwave energy survey meter checked for accuracy by its manufacturer.

6. Troubleshooting

PRECAUTION

1. CHECK GROUNDING BEFORE CHECKING FOR TROUBLE.
2. BE CAREFUL OF THE HIGH VOLTAGE CIRCUIT.
3. DISCHARGE THE HIGH VOLTAGE CAPACITOR.
4. WHEN CHECKING THE CONTINUITY OF THE SWITCHES OR TRANSFORMER, DISCONNECT ONE LEAD WIRE FROM THESE PARTS AND THEN CHECK CONTINUITY WITHOUT THE POWER SOURCE ON. TO DO OTHERWISE MAY RESULT IN A FALSE READING OR DAMAGE TO YOUR METER.
5. DO NOT TOUCH ANY PART OF THE CIRCUIT OR THE CONTROL CIRCUIT BOARD, SINCE STATIC DISCHARGE MAY DAMAGE IT. ALWAYS TOUCH GROUND WHILE WORKING ON IT TO DISCHARGE ANY STATIC CHARGE BUILT UP.

6-1 Electrical Maltunction

SYMPTOM	CAUSE	CORRECTIONS
Oven is dead. Fuse is OK. No display and no operation at all.	<ol style="list-style-type: none"> 1. Open or loose lead wire harness 2. Open thermal cutout (Magnetron) 3. Open low voltage transformer 4. Defective Ass'y PCB 	<p>Check fan motor when thermal cutout is defective.</p> <p>Check Ass'y PCB when LVT is defective.</p>
No display and no operation at all. Fuse is blown.	<ol style="list-style-type: none"> 1. Shorted lead wire harness 2. Defective primary latch switch (NOTE 1) 3. Defective monitor switch (NOTE1) 4. Shorted HVCapacitor 5. Shorted HVTransformer (NOTE2) <p>NOTE 1: All of these switches must be replaced at the same time. (refer to adjustment instructions) Check continuity of power relay contacts and if it has continuity, replace power relay also.</p> <p>NOTE 2: When HVTransformer is replaced, check diode and magnetron also.</p>	<p>Check adjustment of primary, interlock monitor, door sensing switch.</p>
Oven does not accept key input (Program)	<ol style="list-style-type: none"> 1. Key input is not in-Sequence 2. Open or loose connection of membrane key pad to Ass'y PCB 3. Shorted or open membrane panel 4. Defective Ass'y PCB 	<p>Refer to operation procedure.</p> <p>Replace PCB main.</p>
Timer starts countdown but no microwave oscillation. (No heat while oven lamp and fan motor turn on.)	<ol style="list-style-type: none"> 1. Off-alignment of latch switches 2. Open or loose connection of high voltage circuit especially magnetron filament circuit <p>NOTE: Large contact resistance will bring lower magnetron filament voltage and cause magnetron to lower output and/or intermittent oscillation.</p> <ol style="list-style-type: none"> 3. Defective high voltage components H.V.Transformer H.V.Capacitor H.V.Diode, H.V.Fuse Magnetron 4. Open or loose wiring of power relay 5. Defective primary latch switch 6. Defective power relay or Ass'y PCB 	<p>Adjust door and latch switches.</p> <p>Check high voltage component according to component test procedure and replace if it is defective.</p> <p>Replace PCB main.</p>

6-1 Electrical Maltunction(continved)

SYMPTOM	CAUSE	CORRECTIONS
Oven lamp and fan motor turn on	<ol style="list-style-type: none"> Misadjustment or loose wiring of primary latch switch Defective primary latch switch 	Adjust door and latch switches.
Oven can program but timer does not start.	<ol style="list-style-type: none"> Open or loose wiring of secondary interlock switch Off-alignment of primary interlock Defective secondary interlock S/W 	Adjust door and interlock switches.
Microwave output is low;. Oven takes longer time to cook food.	<ol style="list-style-type: none"> Decrease in power source voltage. Open or loose wiring of magnetron filament circuit. (Intermittent oscillation)) Aging of magnetron 	Consult electrician.
Fan motor turns on when plugged in	Loose wiring of door sensing switch	Check wire of door sensing switch.
Oven does not operate and return to the plugged in mode.	Defective Ass'y PCB	Replace PCB main.
Loud buzzing noise can be heard.	<ol style="list-style-type: none"> Loose fan and fan motor Loose screws on H.V.Transformer Shorted H.V.Diode 	Tighten screws of fan motor. Tighten screws of H.V.Transformer. Replace H.V.Diode.
Turntable motor does not rotate.	<ol style="list-style-type: none"> Open or loose wiring of turntable motor. Defective turntable motor. 	Replace turntable motor.
Oven stops operation during cooking	<ol style="list-style-type: none"> Open or loose wiring of primary interlock switch Operation of thermal cutout(Magnetron) 	Adjust door and latch switches.
Sparks	<ol style="list-style-type: none"> Metallic ware or cooking dishes touching on the oven wall. Ceramic ware trimmed with gold or silver powder also causes sparks. 	Inform the customer. Do not use any type of cookware with metallic trimming.
Uneven cooking	Uneven intensity of microwave due to its characteristics.	Wrap thinner parts of the food with aluminum foil. Use plastic wrap or cover with a lid. Stir once or twice while cooking foods such as soup, cocoa, or milk.
Noise from the turntable motor when it starts to operate.	Noise may result from the motor.	Replace turntable motor.

7. Exploded Views and Parts List

7-1 Exploded Views

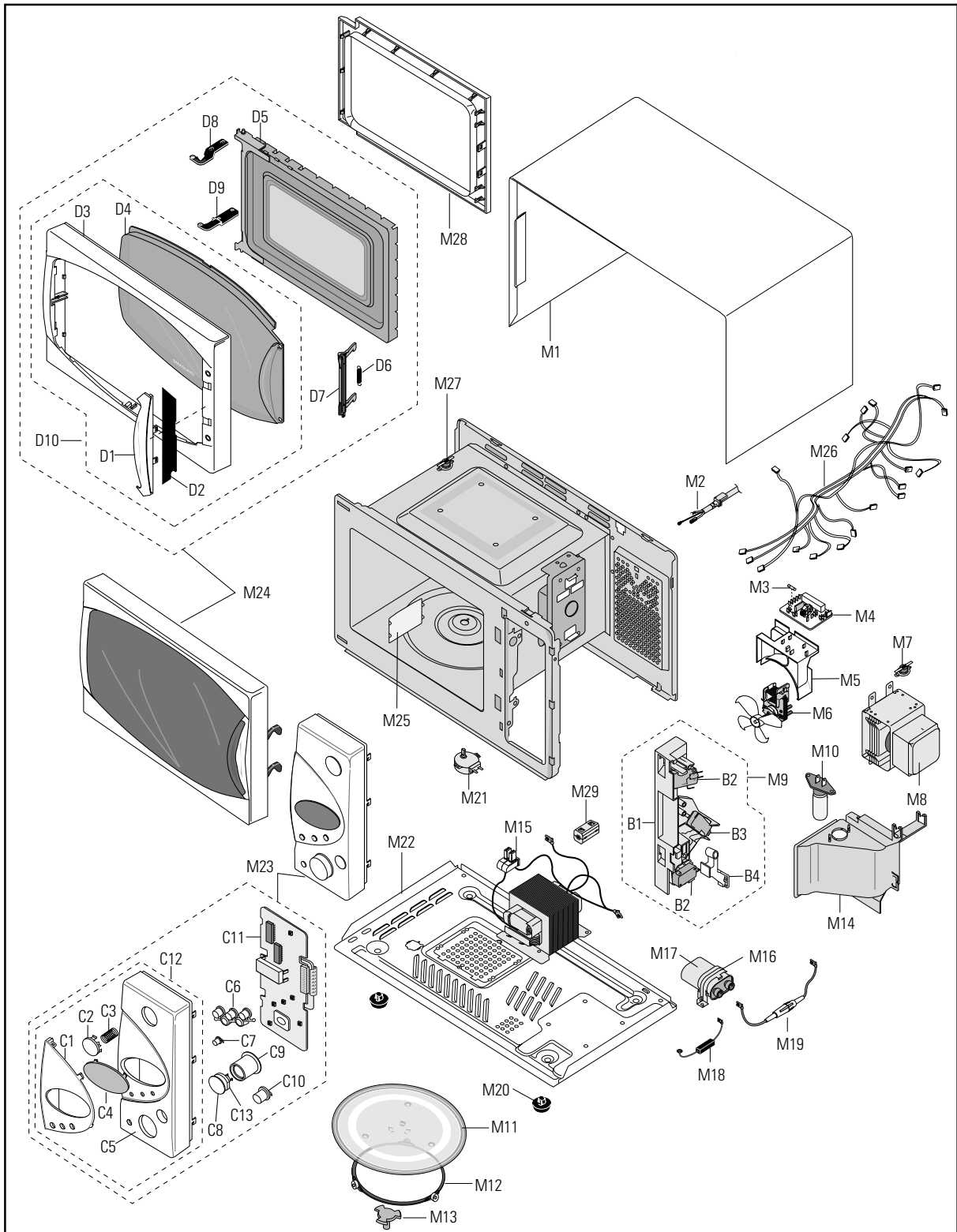

7-2 Main Parts List

Ref. No.	Parts No.	Description/Specification	Q'ty	Remarks
M 1	DE70-30116W	PANEL-OUTER;SECC,T0.5,W351.7,L1014.7,WHT,M	1	
M 2	DE39-20145A	ASSY POWER CORD;MOONSUNG,-,230V50Hz,-,-,M308	1	
M 3	3601-000448	FUSE-FERRULE;250V,10A,SLOW-BLOW,CERAMIC,6.3	1	
M 4	DE96-00007A	ASSY NOISE FILTER;SN-3WEA,250V10A,3W INRUSH TC	1	
M 5	DE71-60467A	COVER-BLOWER;PP,-,-,-,3RD-0.7	1	
M 6	DE96-00031A	ASSY MOTOR-FAN;SMF-3RDEA,230V50HZ,2400RPM,M1733	1	
M 7	DE47-20009A	THERMOSTAT;PW2N-520PB,160/60,250V/7.5A,H,	1	MGT
M 8	DE03-30029A	MAGNETRON;OM75SH(31)JESS	1	▲
M 9	DE93-20020A	ASSY BODY LATCH;RE-43B/90B	1	
M10	4713-001004	LAMP-INCANDESCENT;230V,-,40W,ORG,-,-,25x71mm	1	
M11	DE74-20102B	TRAY-COOKING;GLASS,T5.0,PI288,780G,M745	1	
M12	DE92-90436C	ASSY-GUIDE ROLLER;MW4370W,D16.5,XAREX	1	
M13	DE67-60075A	COUPLER;PPS,7G,BRN,M97G45	1	
M14	DE71-60457A	COVER-AIR;PP,T1.7,W115.5,L150,WHT,3RD-W0	1	
M15	DE26-00014A	TRANS-H.V;SHV-175EC,230V50HZ,2275V/3.40V,-,DY	1	▲
M16	DE61-50106A	BRACKET-HVC;SECC,T0.8,W31,L125.8	1	
M17	2501-001016	C-OIL;950nF,2.1KV,BK,35x54x80,20mm	1	
M18	DE59-40001A	DIODE-H.V;HVR-1X-32B-12	1	
M19	DE91-70061B	ASSY-H.V.FUSE;THV060T-0750-H,5KV0.75A,RED	1	
M20	DE61-40017A	FOOT;PP(A353),BLK,MW5630T	2	
M21	DE31-10154A	MOTOR-DRIVE;M2HJ49ZR02,ST-16,50/60HZ	1	
M22	DE80-10003B	BASE-PLATE;SGCC1-Z,T0.8,W340,L550,3RD-0.7	1	
M23	DE94-00097A	ASSY CONTROL-BOX;230V50HZ,M1774,P-WHT,FISH2	1	▲
M24	DE92-40182M	ASSY DOOR;M1774/XEF,P/WHT,3RD-FISH2	1	▲
M25	DE71-60450B	COVER-MGT;PP,T2,W110.5,L109,-,28G,3RD-0.7	1	
M26	DE39-00052A	WIRE HARNESS-A;230V50HZ,-,-,M1774/XEF,3RD FISH2	1	
M27	DE47-20173A	THERMOSTAT;PW-2N(90/60)30,187Y,250V7.5A,9	1	CAVITY
M28	DE64-40008B	DOOR-C;PP,T1.5,BLK,CE745G	1	
M29	DE73-90027A	FERRITE-CORE;NI-ZN,T13.8,W21.0,L28.0,BNF-14	1	

● : Option Parts

▲ : Warning

▲ :Electrostatically Sensitive Devices

7-3 Door Parts List

Ref. No.	Parts No.	Description / Specification	Q'ty	Remarks
D 1	DE64-20116B	HANDLE-DOOR;ABS,-,-,P/WHT,M1774,3RD-FISH2	1	
D 2	DE01-00099A	FILM-DOOR;PET,T0.13,W23,L177.9,-,M759	1	
D 3	DE64-40277B	DOOR-A;ABS(HR-0370),200G,WHT(W9501),M	1	
D 4	DE64-40278E	SCREEN-DOOR;ACRYL,-,-,SMOG,M1774,3RD-FISH2	1	▲
D 5	DE92-50133C	ASSY DOOR-E;MW4593G,-,BLK,3RD-0.7	1	
D 6	DE61-70033A	SPRING-KEY;ES,HSWR10,PIO.6,D6.0,L22.3,BLU	1	
D 7	DE64-40264C	DOOR-KEY;POM(F20-02),5g,BLK,-,2ND HANDL	1	
D 8	DE61-80005A	HINGE-UPPER;SCP1,T2.3,ZN-COATIN,M745	1	
D 9	DE61-80004A	HINGE-LOWER;SCP1,T2.3,ZN-COATING,M745	1	
D10	DE92-40196L	ASSY DOOR-A;M1774/XEF,P/WHT,3RD-FISH2	1	

7-4 Control Parts List

Ref. No.	Parts No.	Description/Specification	Q'ty	Remarks
C 1	DE71-00005A	COVER-PANEL;ABS(HR0370),-,-,P-WHT,M1774/XEF	1	
C 2	DE66-00013A	BUTTON-SELECT(A);ABS(HR0370),-,-,P/WHT	1	
C 4	DE67-00003A	WINDOW-DISPLAY;SAN,-,-,SMOG,M1774	1	
C 5	DE72-00009A	CONTROL-PANEL;M1774,-,-,P-WHT,FISH2	1	
C 6	DE66-00014A	BUTTON-SELECT(B);ABS(HR0370),-,-,P-WHT,M1774/XEF	1	
C 7	DE66-00016A	BUTTON-CANCEL;ABS(HR0370),-,-,P/WHT	1	
C 8	DE66-20182J	BUTTON-START;ABS,-,2G,P/WHT,M1774,3RD FISH2	1	
C 9	DE64-10127B	KNOB-COVER;ABS(HR0370U),-WHT(W9501),-CE	1	
C10	DE66-00015A	BUTTON-CLOCK;ABS(HR0370),-,-,P/WHT	1	
C11	DE97-00054A	ASSY PCB-MAIN;RC-F207-00,M1774	1	▲
C12	DE94-00157A	ASSY CONTROL-PANEL;230V50HZ,M1774/XEF,P/WHT,3RD-FISH2	1	
C13	DE71-60378A	COVER-LAMP;POM,T2,W19.4,L27,3G,NTR,RE-446	1	

7-5 Body Latch Parts List

Ref. No.	Parts No.	Description / Specification	Q'ty	Remarks
B 1	DE66-40021A	LATCH-BODY;POM(F20-02),50G,RE-330	1	
B 2	3405-000178	SWITCH-MICRO;250V,15A,200gf,SPST-NO	2	
B 3	3405-000175	SWITCH-MICRO;250V,15A,200gf,SPST-NO	1	
B 4	DE66-90054A	LEVER-SWITCH;POM(F20-02),15G,NTR,RE-330	1	

7-6 Standard Parts List

Parts No.	Description / Specification	Q'ty	Remarks
DE60-10012A	SCREW-TAP TITE;TH,+,3,M4,L10,SWR10,ZPC2,TOOTH	1	N/P EARTH
DE60-10012A	SCREW-TAP TITE;TH,+,3,M4,L10,SWR10,ZPC2,TOOTH	1	P/C EARTH
DE60-10012A	SCREW-TAP TITE;TH,+,3,M4,L10,SWR10,ZPC2,TOOTH	1	PCB EARTH
DE60-10063A	SCREW-TAP TH;TH,M4,L12,FEFN	1	O/PANEL
DE60-10080A	SCREW-WASHER;M5,L12,2S	4	HVT
DE60-10080A	SCREW-WASHER;M5,L12,2S	4	MGT
DE60-10082H	SCREW-A;2S-4X12,TOOTHED	1	AIR/COVER
DE60-10082H	SCREW-A;2S-4X12,TOOTHED	2	B/LATCH
DE60-10082H	SCREW-A;2S-4X12,TOOTHED	4	B/PLATE
DE60-10082H	SCREW-A;2S-4X12,TOOTHED	1	C/BLOWER
DE60-10082H	SCREW-A;2S-4X12,TOOTHED	2	C/BOX
DE60-10082H	SCREW-A;2S-4X12,TOOTHED	4	O/PANEL
DE60-10098A	SCREW-ASSY TAP TITE;PH,TC,M4X8,SWRCH18A,ZPC2,GLD,W	1	CAVITY TCO
DE60-10098A	SCREW-ASSY TAP TITE;PH,TC,M4X8,SWRCH18A,ZPC2,GLD,W	2	D/MOTOR
DE60-10098A	SCREW-ASSY TAP TITE;PH,TC,M4X8,SWRCH18A,ZPC2,GLD,W	2	MGT TCO
DE60-30016A	NUT-FLANGE;M4,MSWR10	2	F-MOTOR
DE60-10069A	SCREW-TAP TH;TH,M4,L10,FRFZY	2	SCR/DOOR
DE60-10088A	SCREW-TAP PH;PH,M3,L8,FEFZY,PLAIN	10	PCB
DE60-10098A	SCREW-ASSY TAP TITE;PH,TC,M4X8,SWRCH18A,ZPC2,GLD,W	1	H.V.D
DE60-10012A	SCREW-TAP TITE;TH,+,3,M4,L10,SWR10,ZPC2,TOOTH	1	-

8. P.C.B Diagrams

8-1 P.C.B Diagrams

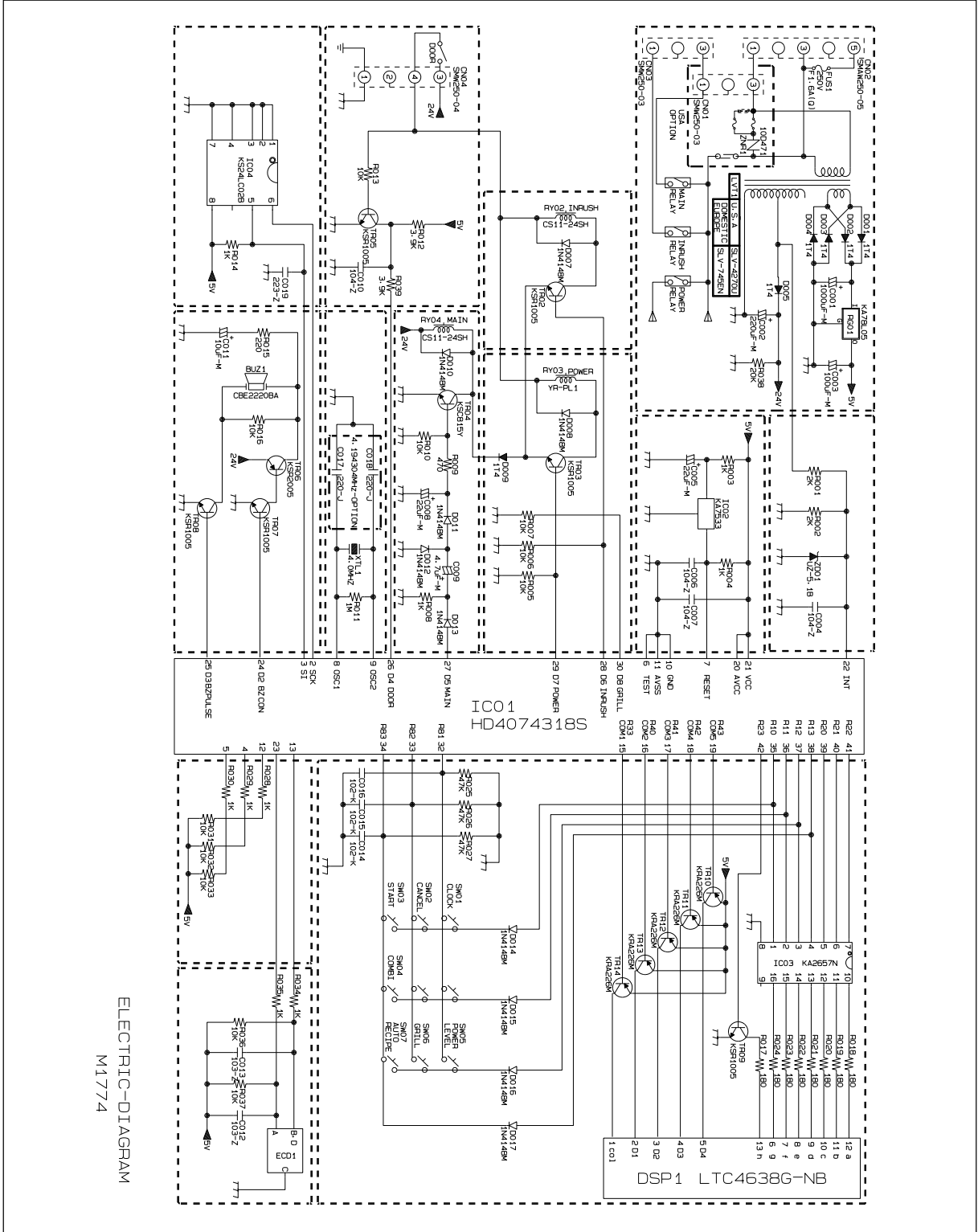

ELECTRIC-DIAGRAM
M1774

8-2 P.C.B Parts List

No.	Parts No.	Description / Specification	Q'ty	Remarks
P 1	0401-001025	DIODE-SWITCHING;1N4148M,50V,450mA,DO-34,TP	5	D007,D008,D010,D011,D012
P 1	0401-001025	DIODE-SWITCHING;1N4148M,50V,450mA,DO-34,TP	5	D013,D014,D015,D016,D017
P 2	0402-001103	DIODE-RECTIFIER;1T4,400V,1A,TS-1,TP	6	D001,D002,D003,D004,D005,D009
P 3	0403-000355	DIODE-ZENER;UZ5.1BSB,5.1V,4.97-5.18V,500mW	1	ZD01
P 4	0501-000388	TR-SMALL SIGNAL;KSC815,NPN,400mW,TO-92,BK,120-	1	TR04
P 5	0504-001014	TR-DIGITAL;KSR1005,NPN,300MW,4.7K/10K,TO-92,TP	6	TR02,TR03,TR05,TR07,TR08,TR09
P 6	0504-001015	TR-DIGITAL;KSR1005,PNP,300MW,4.7K/10K,TO-92,TP	1	TR06
P 7	0504-001044	TR-DIGITAL;KRA226M,PNP,400MW,2.2K/10K,TO-92M,TP	5	TR10,TR11,TR12,TR13,TR14
P 8	1203-0000460	IC-POSI.FIXED REG.;78L05,TO-92,3P,-,PLASTIC,4.8/5	1	RG01
P 9	2001-000032	R-CARBON;180OHM,5%,1/4W,AA,TP,2.4X6.4MM	6	R017,R018,R019,R020,R021,R022
P 9	2001-000032	R-CARBON;180OHM,5%,1/4W,AA,TP,2.4X6.4MM	2	R023,R024
P10	2001-000290	R-CARBON;10KOHM,5%,1/8W,AA,TP,1.8X3.2MM	6	R005,R006,R007,R010,R013,R016
P10	2001-000290	R-CARBON;10KOHM,5%,1/8W,AA,TP,1.8X3.2MM	5	R031,R032,R033,R036,R037
P11	2001-000429	R-CARBON;1KOHM,5%,1/8W,AA,TP,1.8X3.2MM	6	R003,R004,R008,R028,R029,R030
P11	2001-000429	R-CARBON;1KOHM,5%,1/8W,AA,TP,1.8X3.2MM	2	R034,R035
P12	2001-000435	R-CARBON;1MOHM,5%,1/8W,AA,TP,1.8X3.2MM	1	R011
P13	2001-000515	R-CARBON;220OHM,5%,1/8W,AA,TP,1.8X3.2MM	1	R015
P14	2001-000577	R-CARBON;2KOHM,5%,1/8W,AA,TP,1.8X3.2MM	2	R001,R002
P15	2001-000613	R-CARBON;3.9KOHM,5%,1/8W,AA,TP,1.8X3.2MM	2	R012,R039
P16	2001-000780	R-CARBON;470OHM,5%,1/8W,AA,TP,1.8X3.2MM	1	R009
P17	2001-000786	R-CARBON;47KOHM,5%,1/8W,AA,TP,1.8X3.2MM	3	R025,R026,R027
P18	2202-000127	C-CERAMIC,MLC-AXIAL;10nF,+80-20%,25V,Y5V,TP,-,7.5	2	C012,C013
P19	2202-000173	C-CERAMIC,MLC-AXIAL;1nF,10%,50V,Y5P,TP,1.9x3.5	3	C014,C015,C016
P20	2202-000780	C-CERAMIC,MLC-AXIAL;100nF,+80-20%,50V,Y5V,TP,3.5x1	4	C004,C006,C007,C010
P21	2401-000151	C-AL;1000uF,20%,25V,GP,TP,12.5x20,5	1	C001
P22	2401-000244	C-AL;100uF,20%,10V,GP,TP,6.3x7,5	1	C003
P23	2401-000466	C-AL;10uF,20%,35V,GP,TP,5x7,5	1	C011
P24	2401-000914	C-AL;22uF,20%,16V,GP,TP,5x11,5	2	C005,C008
P25	2401-002075	C-AL;4.7uF,20%,50V,GP,TP,5x11,5	1	C009
P26	2401-002598	C-AL;220uF,20%,50V,GP,TP,10x16,5	1	C002
P27	2802-000161	RESONATOR-CERAMIC;4MHz,0.5%,TP,10.0x5.0x7.5mm	1	XTL1
P28	3404-001022	SWITCH-TACT;15V,20mA,130±40gf,6x6x5mm,SPS	5	SW01,SW02,SW03,SW04,SW05
P28	3404-001022	SWITCH-TACT;15V,20mA,130±40gf,6x6x5mm,SPS	2	SW06,SW07
P30	3711-000940	CONNECTOR-HEADER;BOX,4P,1R,2.5mm,STRAIGHT,SN	1	CN04
P31	3711-004142	CONNECTOR-HEADER;BOX,3P/5P,1R,5mm/2.5mm,STRAIGH	1	CN02
P32	3711-004143	CONNECTOR-HEADER;BOX,2P/3P,1R,5mm/2.5mm,STRAIGH	1	CN03
P33	DE13-20009A	IC,KA7533,DIP	1	IC02
P34	DE39-60001A	WIRE-SO COPPER;PIO.6,SN,T,52MM,TAPING_WIRE	6	J001,J002,J003,J004,J005,J006
P34	DE39-60001A	WIRE-SO COPPER;PIO.6,SN,T,52MM,TAPING_WIRE	6	J007,J008,J009,J010,J011,J012
P34	DE39-60001A	WIRE-SO COPPER;PIO.6,SN,T,52MM,TAPING_WIRE	3	J013,J014,J015
P35	3501-001050	RELAY-MINIATURE;24VDC,200mW,5A,1FormA,10mS,5mS	2	RY01,RY02
P36	3501-001062	RELAY-POWER;24VDC,523.2mW,16A,1FormA,15mS,	1	RY03
P37	3601-001126	FUSE-FERRULE;250V,1.6A,QUICK-ACTING,CERAMIC	1	FUS1
P38	3708-001315	CONNECTOR-FPC/FC/PIC;12P,2mm,STRAIGHT,SN	1	CN05
P39	DE07-20126A	LED DISPLAY;LTC-4638G,GRN,12,30,48.2X22.38	1	DSP1
P40	DE09-00035A	IC-MCU;HD404316-D83S,M1974,4BIT	1	IC01
P41	DE13-20013A	IC-DRIVE;KA2657,DIP	1	IC03
P42	DE26-20146A	TRANS-L.V;SLV-745EN,230V,50HZ,AC17/7V	1	LVT1
P43	DE30-20016A	BUZZER;CBE2220BA,STICK	1	BUZ1
P44	DE34-20071A	SWITCH-ROTARY;DC10V,1MA,SH,PA-1005A-003-000	1	ECD1
P45	DE39-40723A	WIRE HARNESS;DC35V,C-959G,80mm,12PIN	1	WIR1
P46	DE47-40024A	HOLDER-FUSE;FH-51H,7.5A	1	FUS1

9. Schematic Diagrams

9-1 Schematic Diagrams

MI 774 WIRING DIAGRAM INRUSH

