

Figure 5-2. Vertical Attenuators

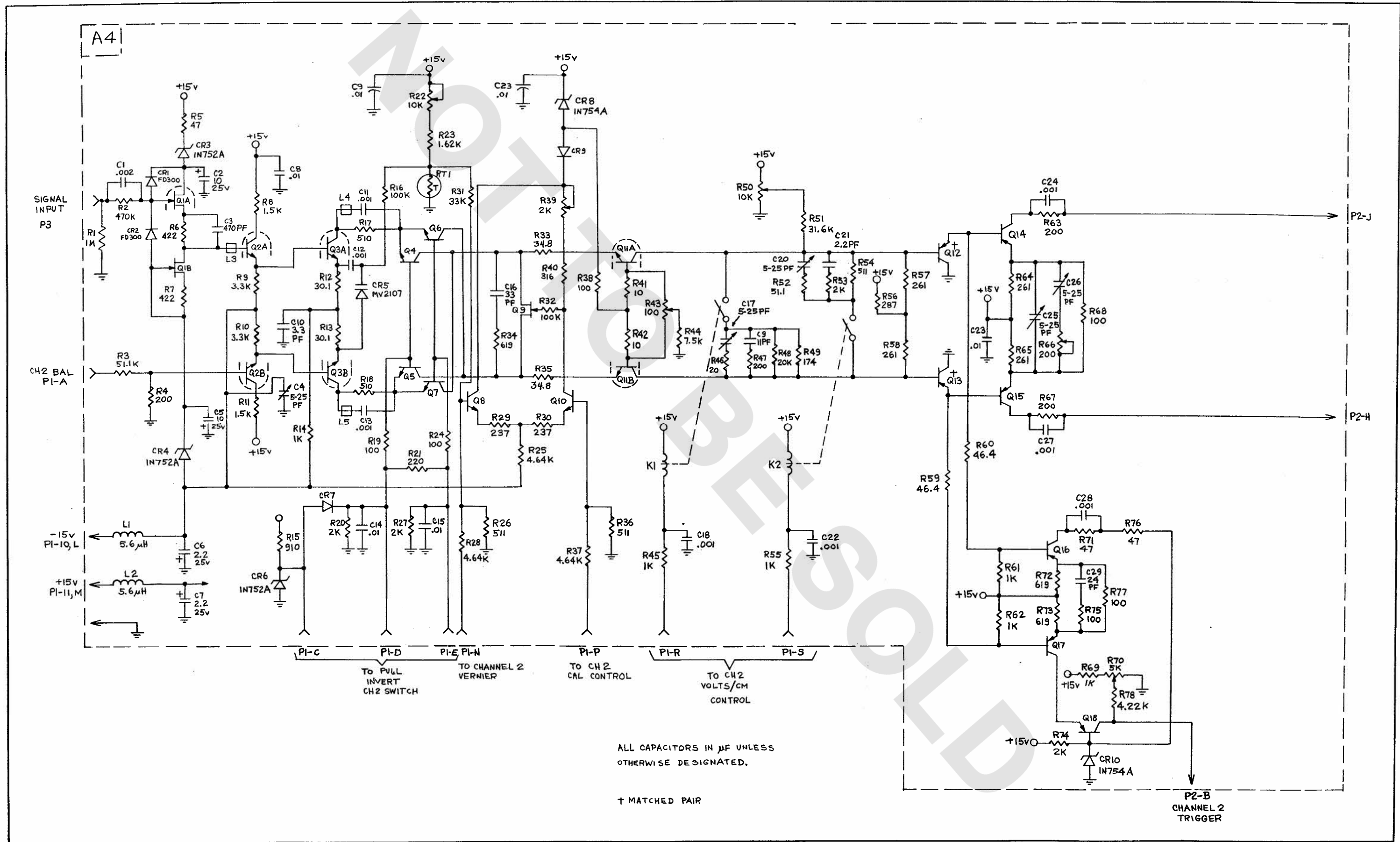

Figure 5-3. Vertical Preamplifier

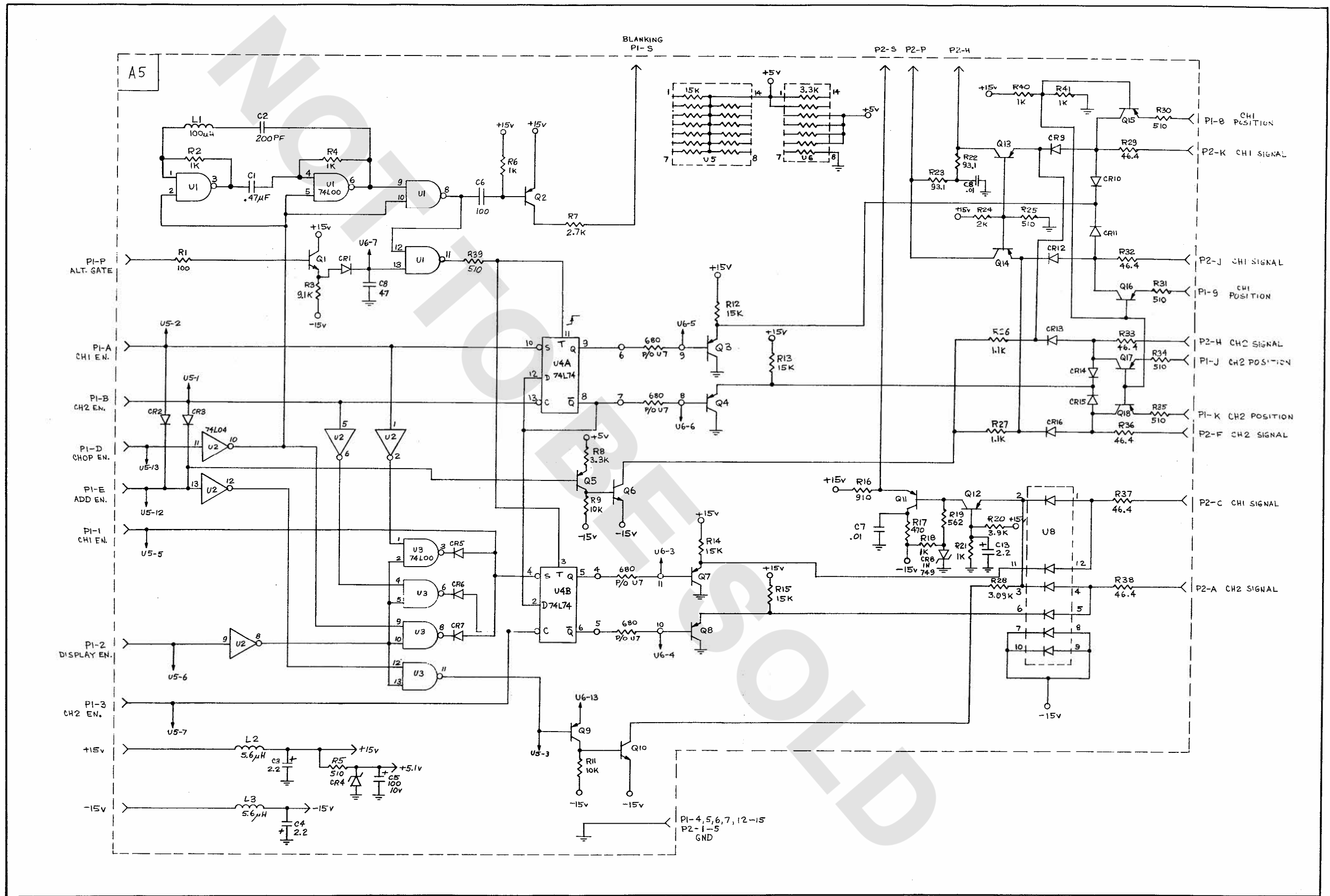

Figure 5-4. Vertical Switching

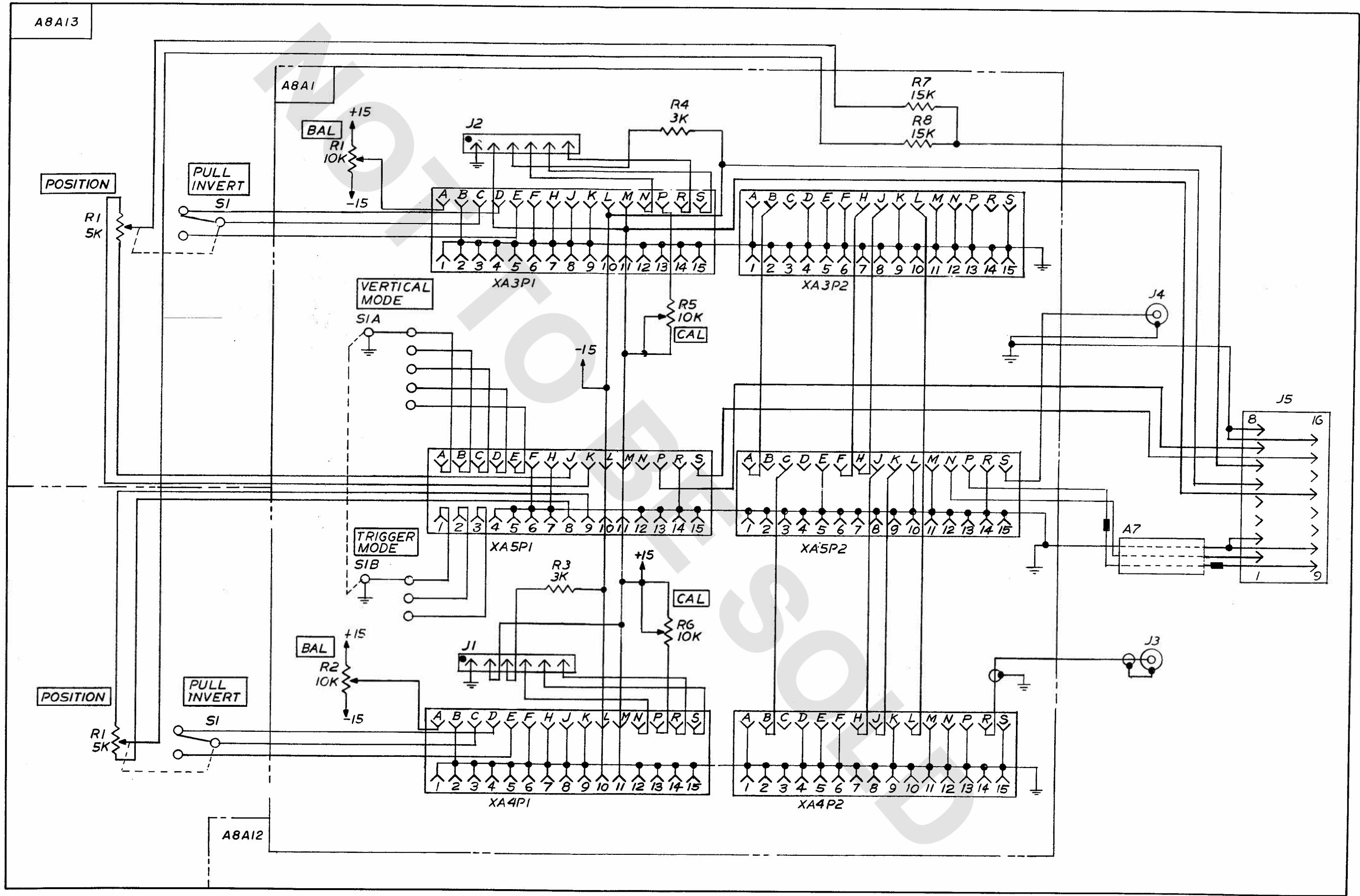

Figure 5-5. Vertical Motherboard and Controls

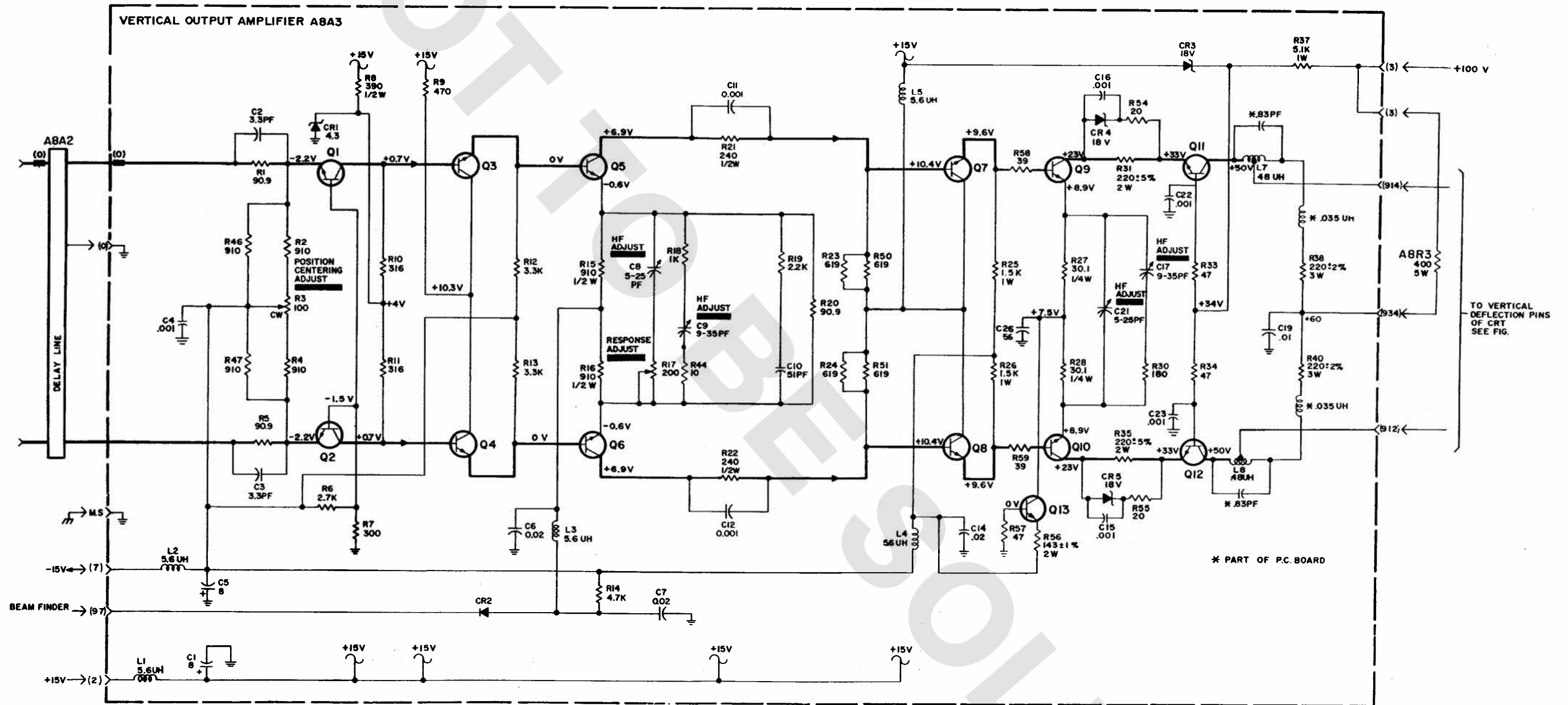

Figure 5-6. Vertical Output Amplifier



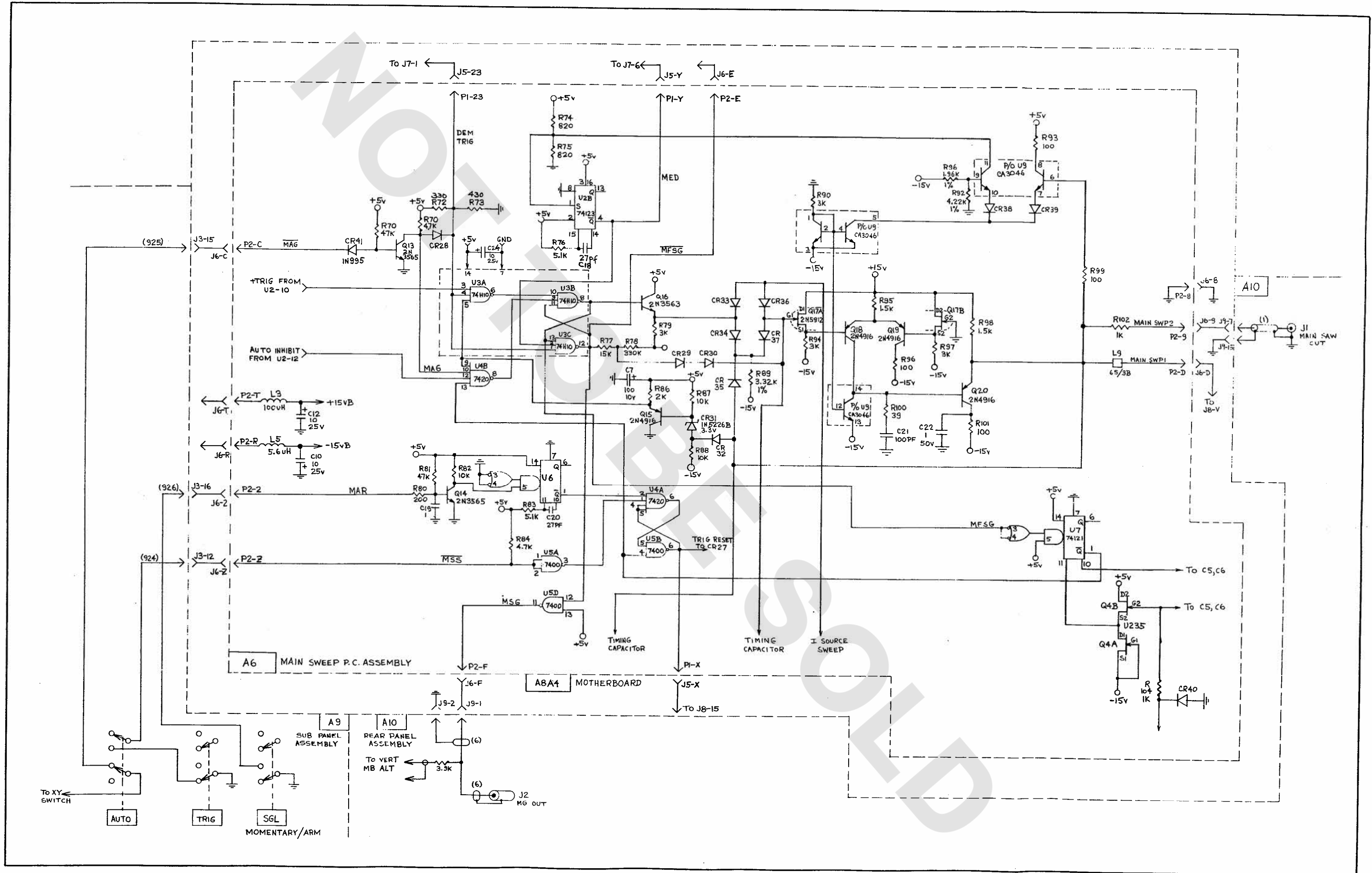

Figure 5-8. Main Sweep Generator

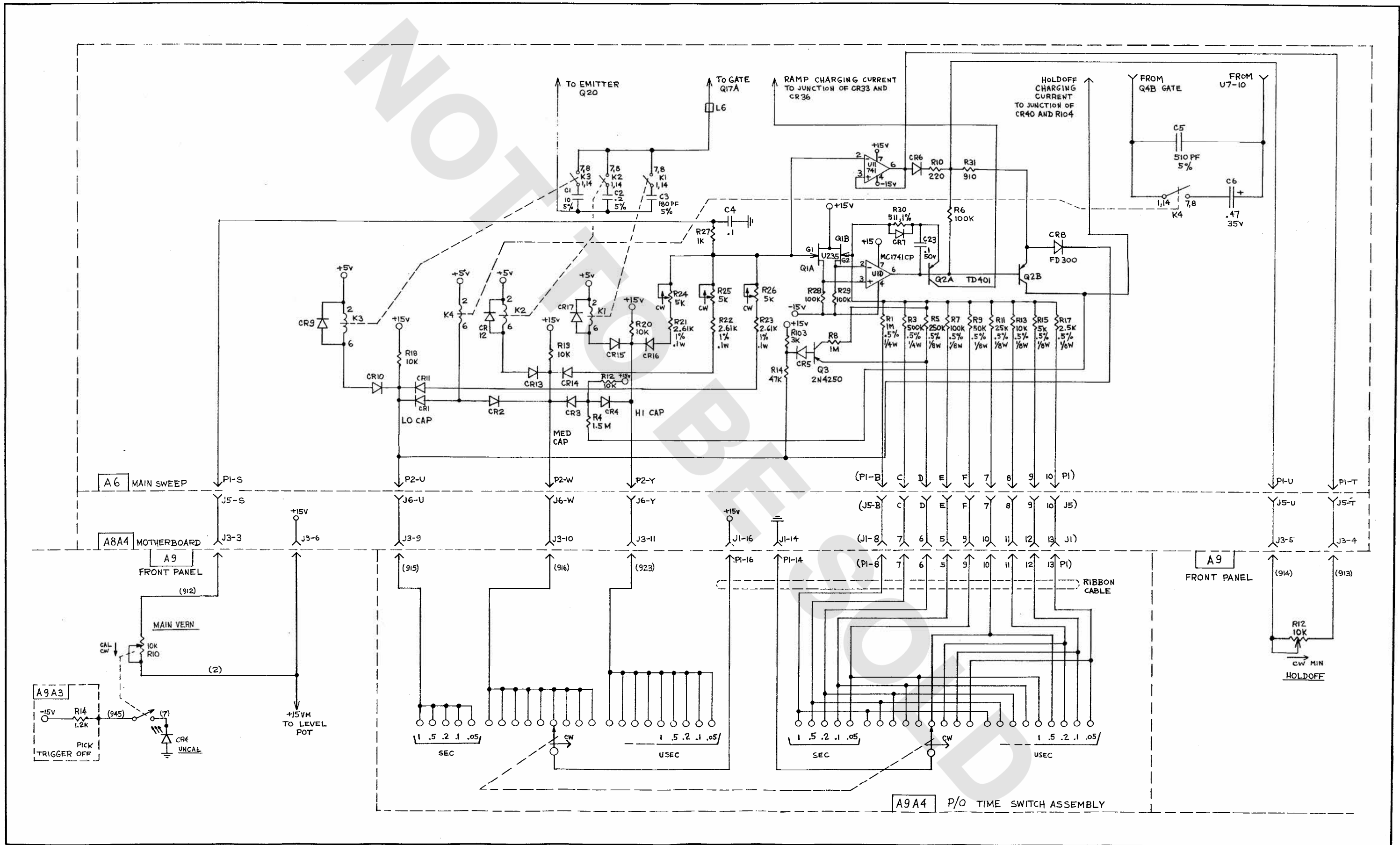

Figure 5-9. Main Sweep Timing