

Figure 5-10. Delayed Trigger Generator

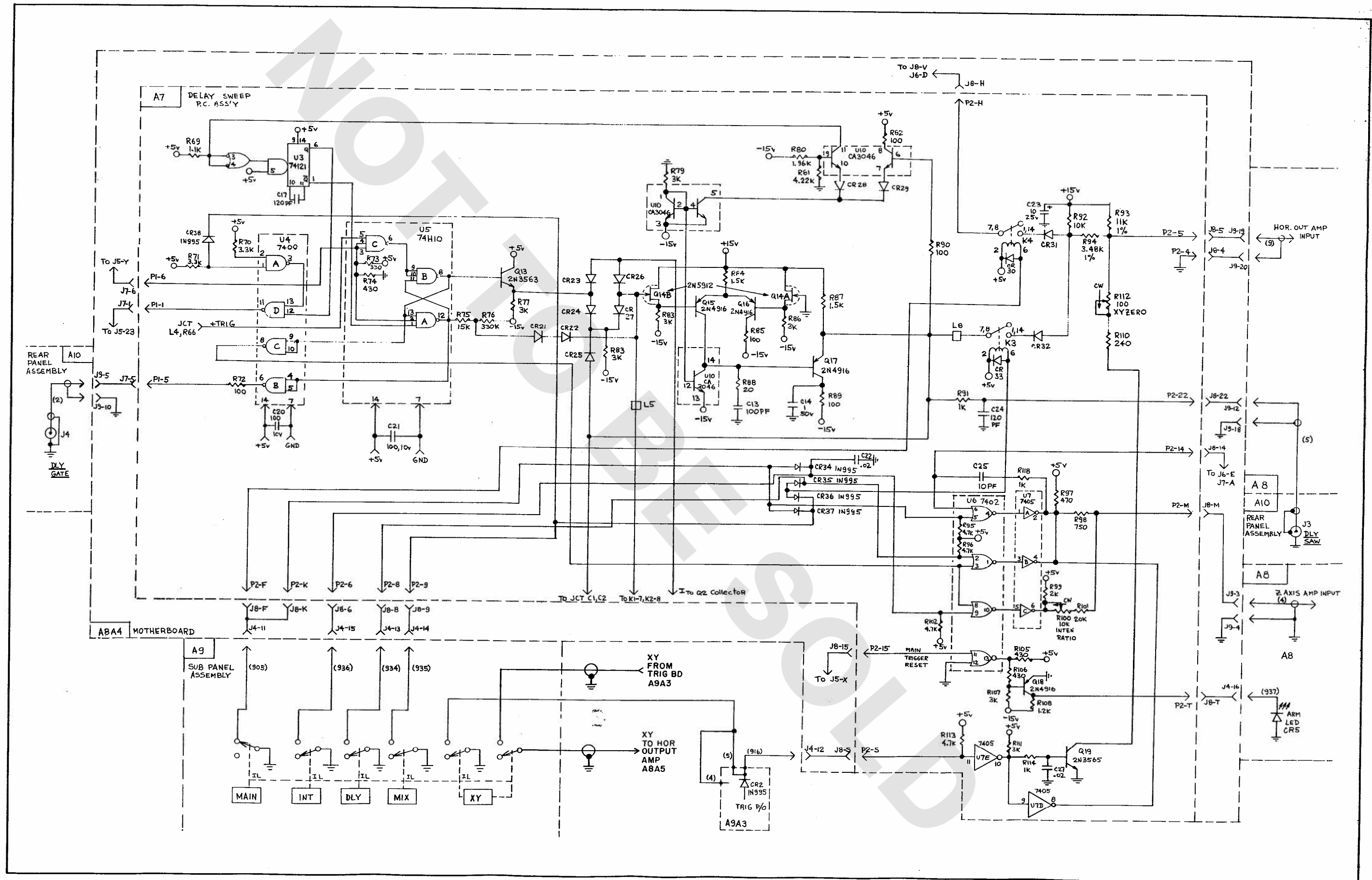

Figure 5-11. Delayed Sweep Generator and Display Logic

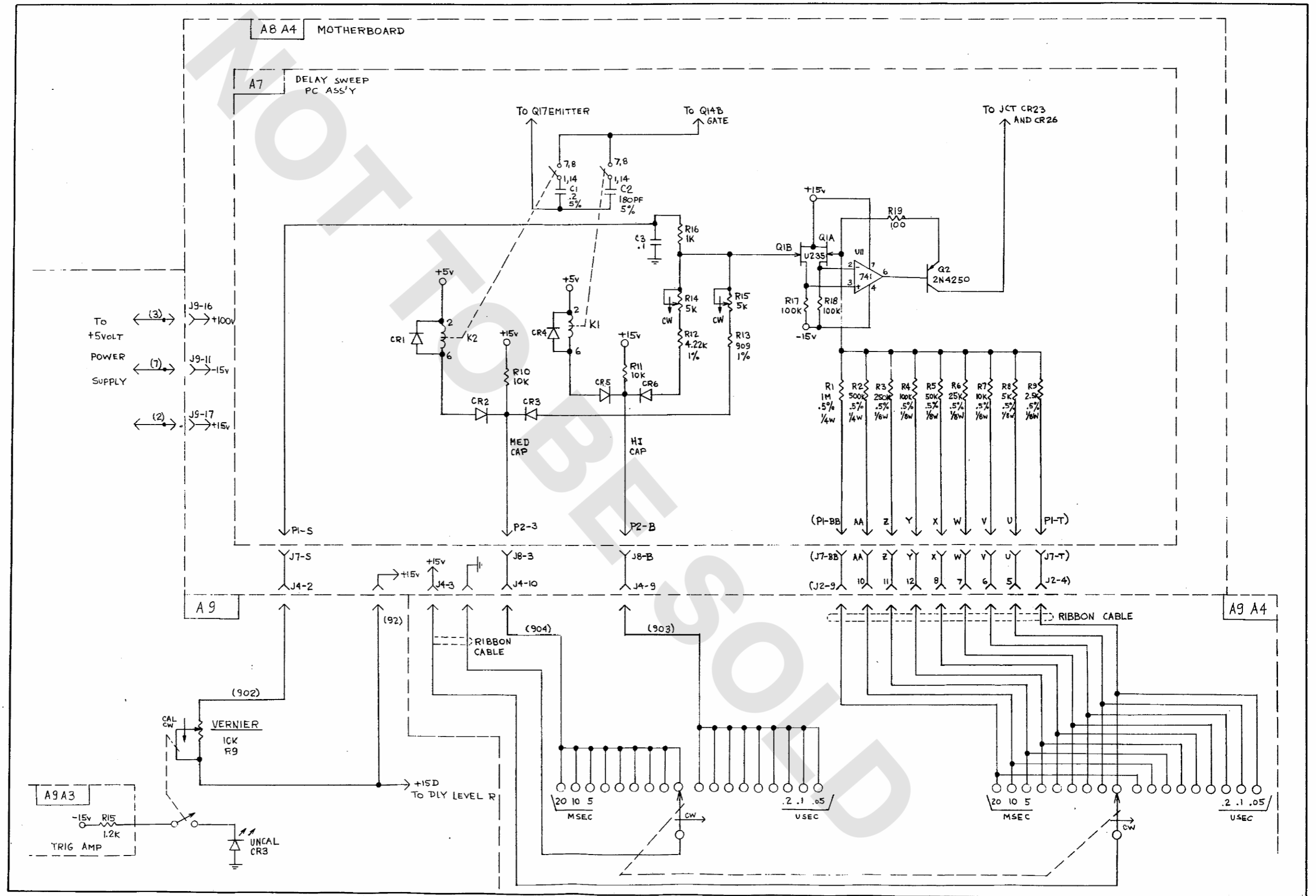

Figure 5-12. Delayed Sweep Timing

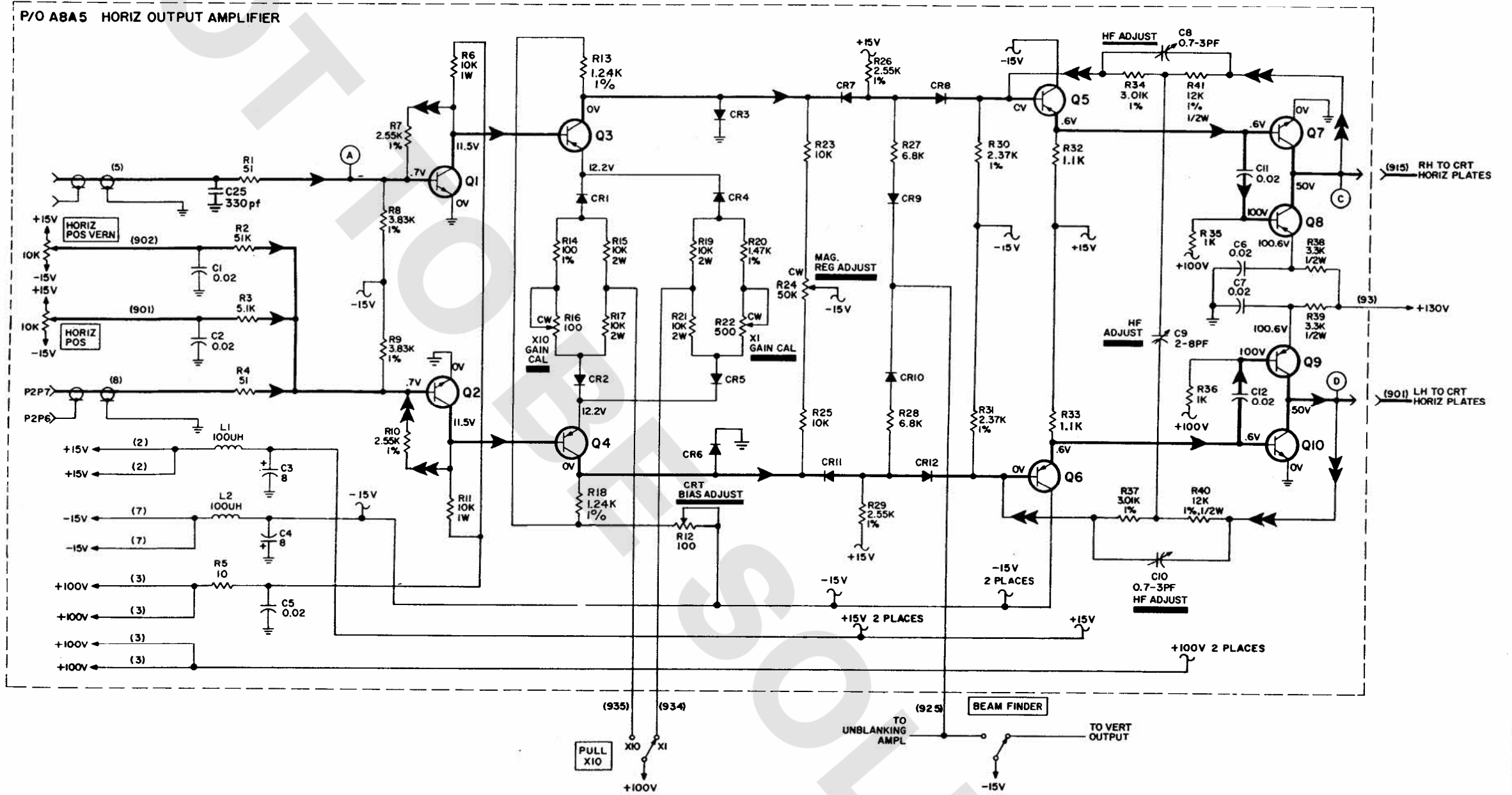
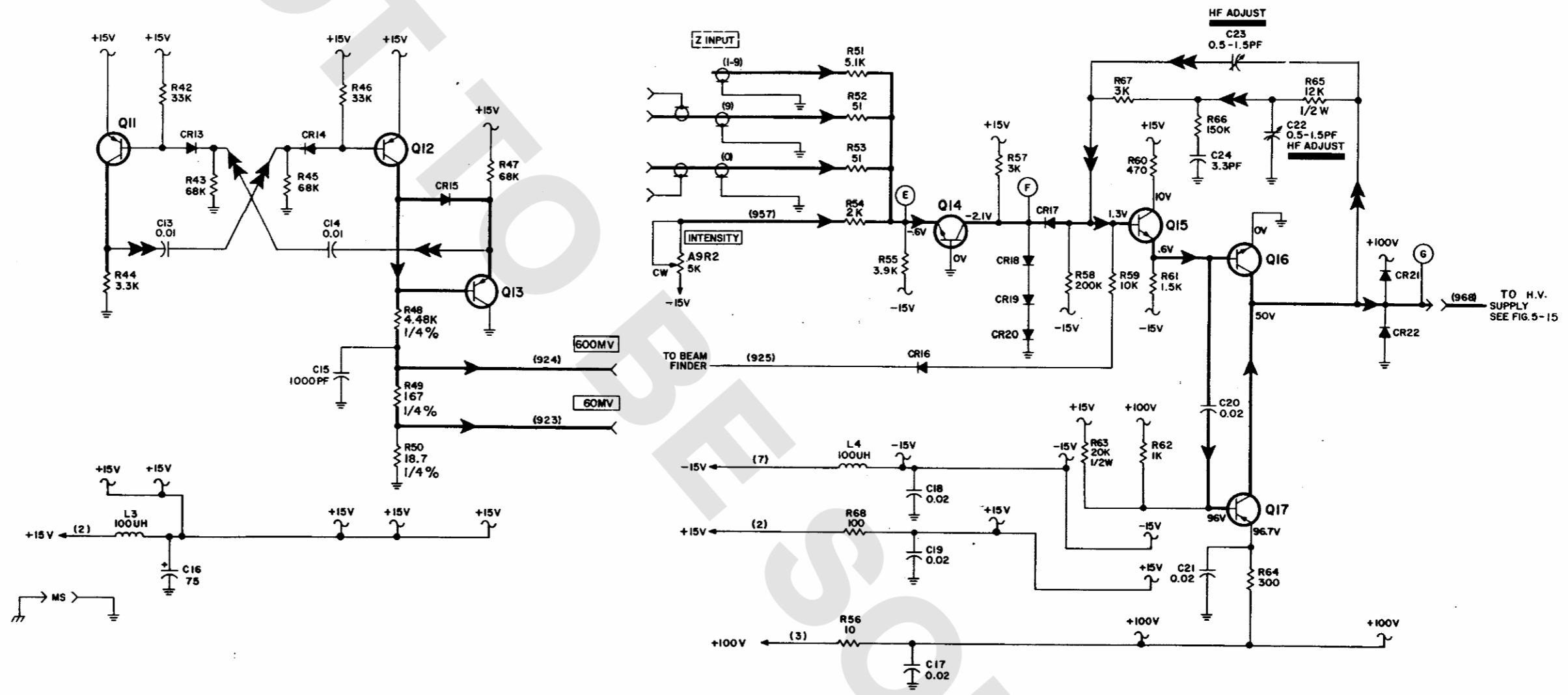

Figure 5-13. Horizontal Output Amplifier



CALIBRATOR (P/OA8A5)

UNBLANKING AMPLIFIER (P/OA8A5)

Figure 5-14. Calibrator and Unblanking

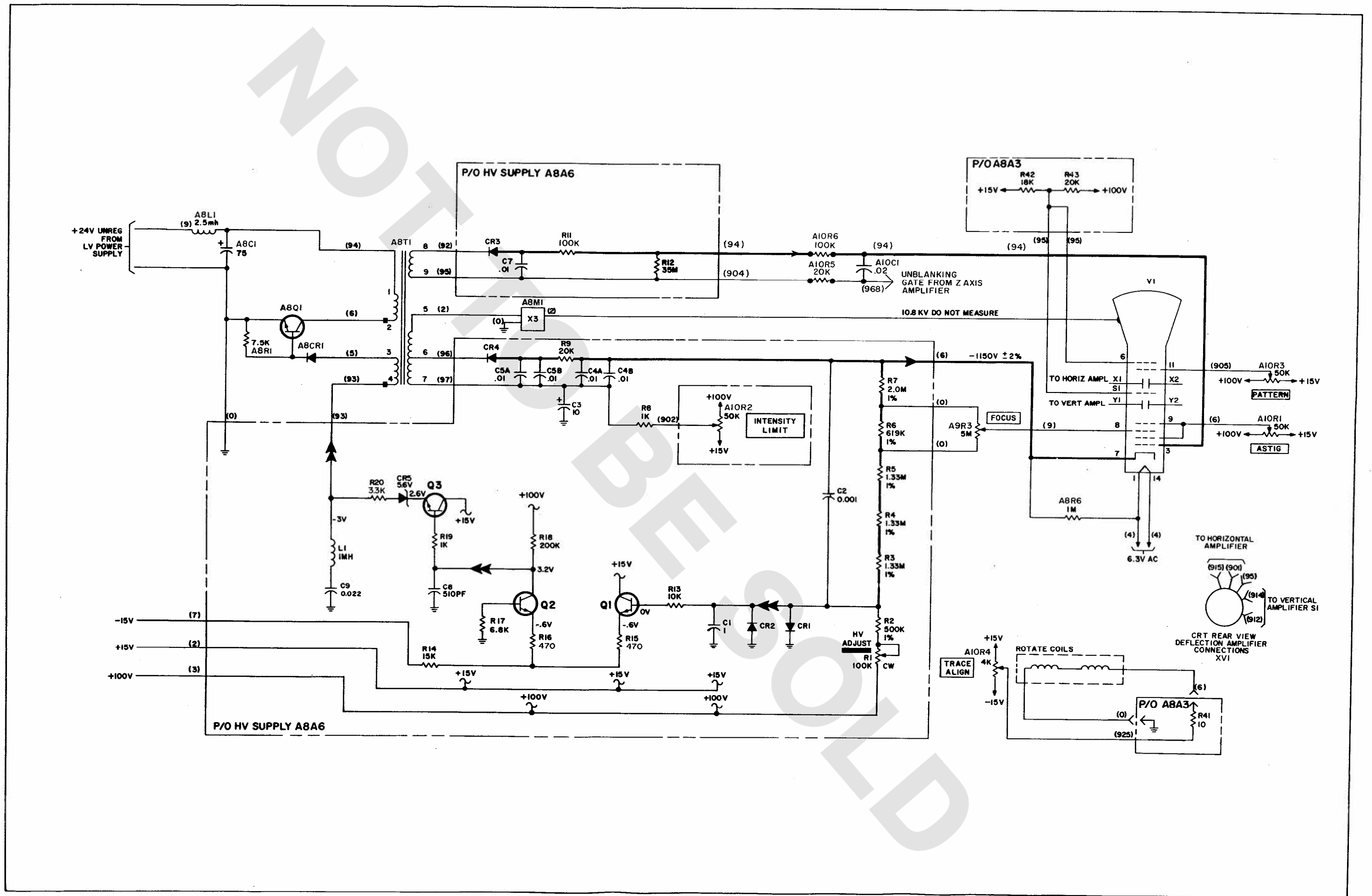

Figure 5-15. CRT and High Voltage Power Supply

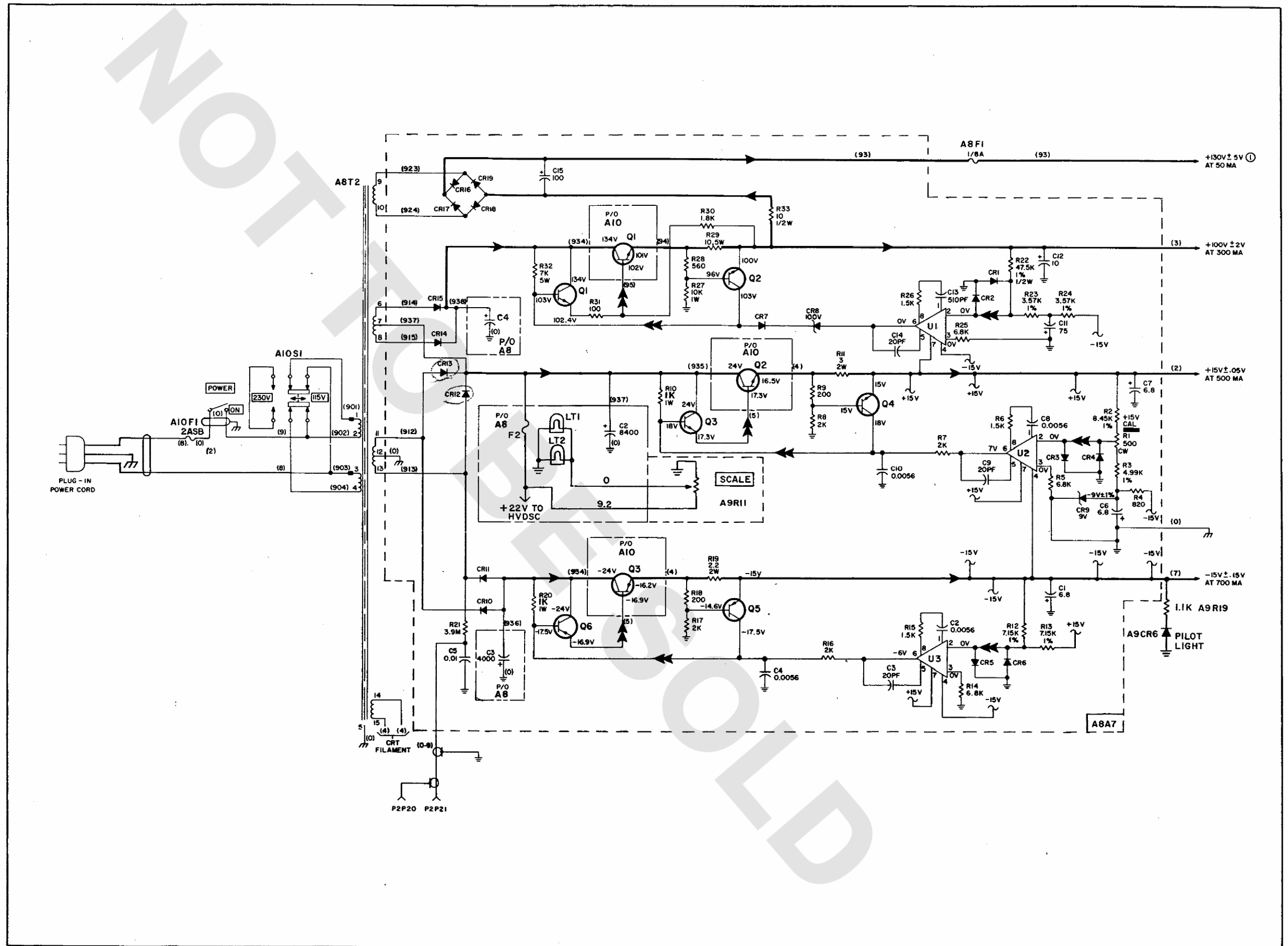

Figure 5-16. Low Voltage Power Supply

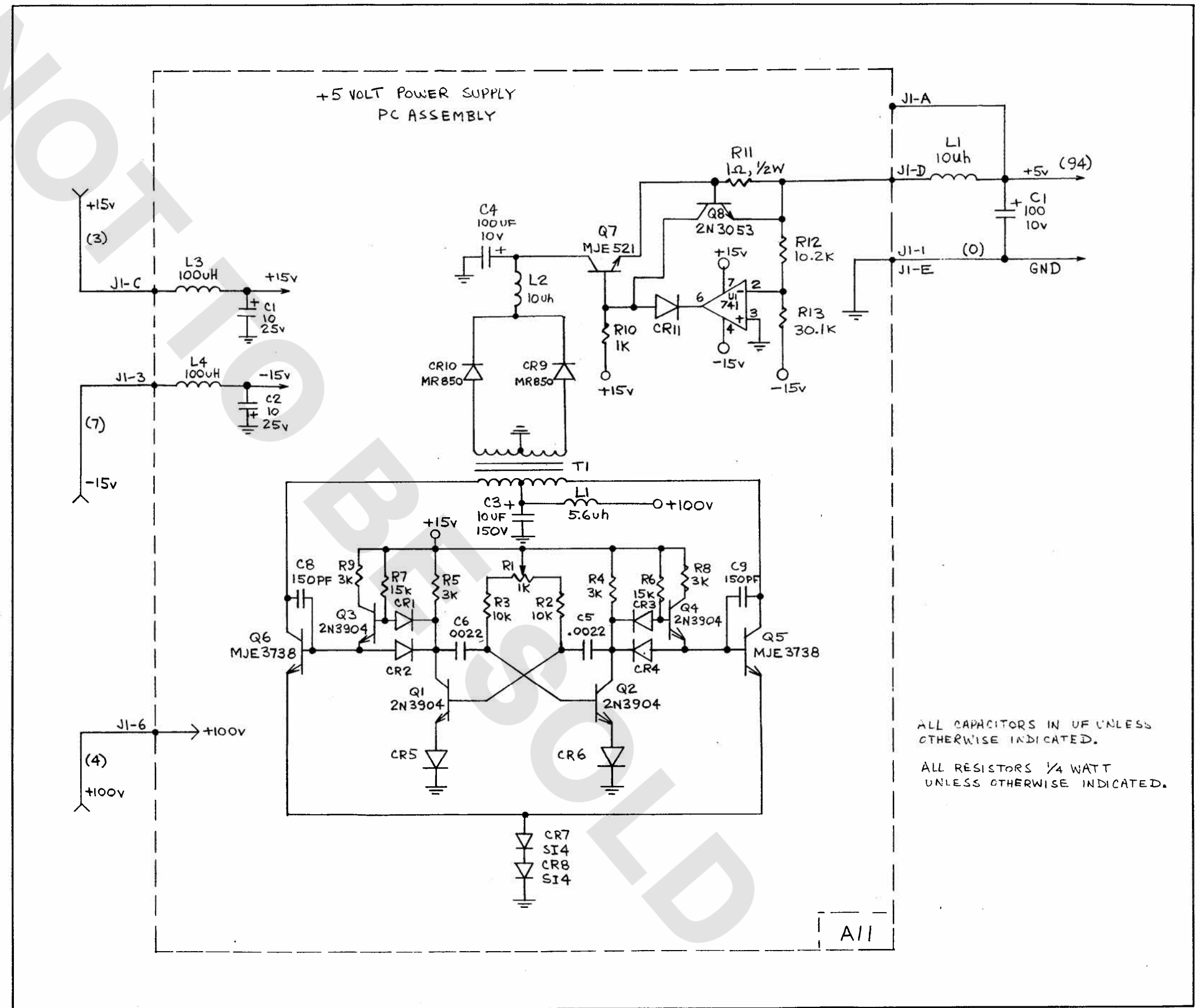

Figure 5-17. 5 Volt Power Supply