

STR-DE497P/K4800P/K5800P

SERVICE MANUAL

Ver 1.1 2004. 10



US Model
STR-K4800P/K5800P

Canadian Model
STR-K4800P

AEP Model
UK Model
STR-DE497P

- STR-DE497P/K4800P/K5800P are the FM/AM receiver section in HT-DDW760/4800DP/5800DP.

Photo: STR-K5800P

Manufactured under license from Dolby Laboratories. "Dolby", "Pro Logic" and the double-D symbol are trademarks of Dolby Laboratories. "DTS" and "DTS Digital Surround" are registered trademarks of Digital Theater Systems, Inc.

SPECIFICATIONS

AUDIO POWER SPECIFICATIONS

POWER OUTPUT AND TOTAL HARMONIC DISTORTION:

(Models of area code US only)

With 6 ohm loads, both channels driven, from 120 – 20,000 Hz; rated 80 watts (STR-K5800P)/ 60 watts (STR-K4800P) per channel minimum RMS power, with no more than 0.7 % total harmonic distortion from 250 milliwatts to rated output.

Amplifier section

Power Output ¹⁾

Models of area code US
(6 ohms 1 kHz, THD 10 %)

STR-K5800P: FRONT ²⁾: 120 W/ch
CENTER ²⁾: 120 W
SURR ²⁾: 120 W/ch

STR-K4800P: FRONT ²⁾: 100 W/ch
CENTER ²⁾: 100 W
SURR ²⁾: 100 W/ch

Models of area code CND
(6 ohms 1 kHz, THD 0.7 %)

FRONT ²⁾: 80 W/ch
CENTER ²⁾: 80 W
SURR ²⁾: 80 W/ch

(6 ohms 1 kHz, THD 10 %)

FRONT ²⁾: 100 W/ch
CENTER ²⁾: 100 W
SURR ²⁾: 100 W/ch

Models of area code AEP, UK
(6 ohms 1 kHz, THD 0.7 %)

FRONT ²⁾: 80 W/ch
CENTER ²⁾: 80 W
SURR ²⁾: 80 W/ch

(6 ohms 1 kHz, THD 10 %)

FRONT ²⁾: 100 W/ch
CENTER ²⁾: 100 W
SURR ²⁾: 100 W/ch

1) Measured under the following conditions:

Area code	Power requirements
US, CND	120 V AC, 60 Hz
AEP, UK	230 V AC, 50 Hz

2) Depending on the sound field settings and the source, there may be no sound output.

Inputs (Analog)

MULTI CH IN [*] , CD, MD/TAPE, VIDEO 1, 2, DVD	Sensitivity: 800 mV Impedance: 50 kilohms
---	--

Inputs (Digital)

DVD (Coaxial)	Sensitivity: – Impedance: 75 ohms
VIDEO 2 (Optical)	Sensitivity: – Impedance: –

– Continued on next page –

FM STEREO/FM-AM RECEIVER

9-879-027-02

2004J04-1

© 2004. 10

Sony Corporation

Audio Group

Published by Sony Engineering Corporation

SONY®

STR-DE497P/K4800P/K5800P

Outputs (Analog)

MD/TAPE (OUT), VIDEO 1 (AUDIO OUT)	Voltage: 800 mV Impedance: 10 kilohms
SUB WOOFER	Voltage: 2 V Impedance: 1 kilohms

Reproduction frequency range:
28 – 20,000 Hz

Tone

Gain levels	±6 dB, 1 dB step
-------------	------------------

* Models of area code AEP, UK only.

FM tuner section

Tuning range	87.5 – 108.0 MHz
Antenna	FM wire antenna
Antenna terminals	75 ohms, unbalanced
Intermediate frequency	10.7 MHz

AM tuner section

Tuning range
Models of area code US, CND
With 10-kHz tuning scale: 530 – 1,710 kHz³⁾
With 9-kHz tuning scale: 531 – 1,710 kHz³⁾

Models of area code AEP, UK
With 9-kHz tuning scale: 531 – 1,602 kHz

Antenna	Loop antenna
Intermediate frequency	450 kHz

3) You can change the AM tuning scale to 9 kHz or 10 kHz.
After tuning in any AM station, turn off the receiver. While holding down PRESET TUNING + or TUNING +, press I/⏻. All preset stations will be erased when you change the tuning scale. To reset the scale to 10 kHz (or 9 kHz), repeat the procedure.

Video section

Inputs/Outputs	
Video:	1 Vp-p, 75 ohms

General

Power requirements

Area code	Power requirements
US, CND	120 V AC, 60 Hz
AEP, UK	230 V AC, 50/60 Hz

Power consumption

Area code	Power consumption
US (STR-K4800P)	165 W
US (STR-K5800P)	180 W
CND	225 VA
AEP, UK	150 W

Power consumption (during standby mode)
0.3 W

Dimensions (w/h/d) (Approx.)
430 × 145 × 310.5 mm
(17 × 5 ⁶/₈ × 11 ⁷/₈ inches)
including projecting parts
and controls

Mass (Approx.)
6.5 kg (14 lb 6 oz)

Design and specifications are subject to change
without notice.

- Abbreviation
CND : Canadian model

SAFETY CHECK-OUT

After correcting the original service problem, perform the following safety check before releasing the set to the customer:
 Check the antenna terminals, metal trim, "metallized" knobs, screws, and all other exposed metal parts for AC leakage.
 Check leakage as described below.

LEAKAGE TEST

The AC leakage from any exposed metal part to earth ground and from all exposed metal parts to any exposed metal part having a return to chassis, must not exceed 0.5 mA (500 microamperes.). Leakage current can be measured by any one of three methods.

1. A commercial leakage tester, such as the Simpson 229 or RCA WT-540A. Follow the manufacturers' instructions to use these instruments.
2. A battery-operated AC milliammeter. The Data Precision 245 digital multimeter is suitable for this job.
3. Measuring the voltage drop across a resistor by means of a VOM or battery-operated AC voltmeter. The "limit" indication is 0.75 V, so analog meters must have an accurate low-voltage scale. The Simpson 250 and Sanwa SH-63Trd are examples of a passive VOM that is suitable. Nearly all battery operated digital multimeters that have a 2 V AC range are suitable. (See Fig. A)

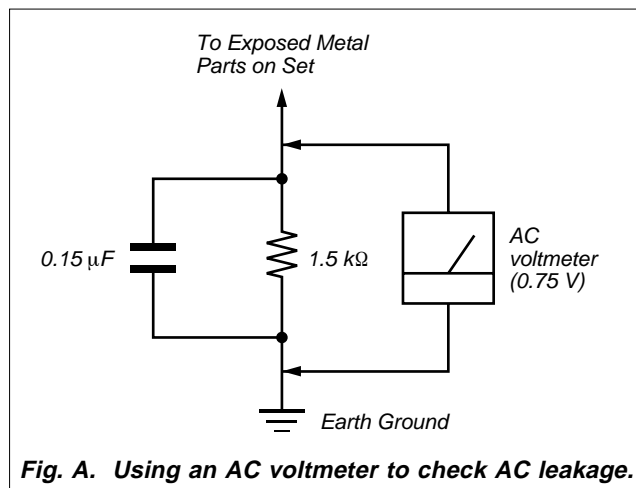

MODEL IDENTIFICATION

— BACK PANEL —

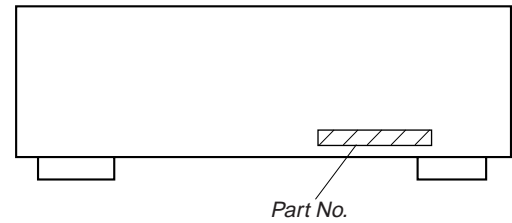

MODEL	PART No.
STR-DE497P: AEP	4-252-088-0□
STR-DE497P: UK	4-252-088-1□
STR-K4800P: US	4-252-088-2□
STR-K4800P: CND	4-252-088-3□
STR-K5800P: US	4-252-088-6□

- Abbreviation
 CND: Canadian model

SAFETY-RELATED COMPONENT WARNING!!

COMPONENTS IDENTIFIED BY MARK Δ OR DOTTED LINE WITH MARK Δ ON THE SCHEMATIC DIAGRAMS AND IN THE PARTS LIST ARE CRITICAL TO SAFE OPERATION. REPLACE THESE COMPONENTS WITH SONY PARTS WHOSE PART NUMBERS APPEAR AS SHOWN IN THIS MANUAL OR IN SUPPLEMENTS PUBLISHED BY SONY.

ATTENTION AU COMPOSANT AYANT RAPPORT À LA SÉCURITÉ!!

LES COMPOSANTS IDENTIFIÉS PAR UNE MARQUE Δ SUR LES DIAGRAMMES SCHÉMATIQUES ET LA LISTE DES PIÈCES SONT CRITIQUES POUR LA SÉCURITÉ DE FONCTIONNEMENT. NE REMPLACER CES COMPOSANTS QUE PAR DES PIÈCES SONY DONT LES NUMÉROS SONT DONNÉS DANS CE MANUEL OU DANS LES SUPPLÉMENTS PUBLIÉS PAR SONY.

TABLE OF CONTENTS

1. GENERAL

Main unit (STR-DE497P)	5
Main unit (STR-K4800P/K5800P)	7
Remote button description	9

2. DISASSEMBLY

2-1. Case	10
2-2. Front Panel Section	11
2-3. Back Panel	11
2-4. Digital Board	12
2-5. Standby Board	12
2-6. Main Board	13

3. TEST MODE 14

4. DIAGRAMS

4-1. Circuit Boards Location	15
4-2. Block Diagram – Tuner/Audio Section –	16
4-3. Block Diagram – Digital Section –	17
4-4. Block Diagram – Video/Display Section –	18
4-5. Block Diagram – Power Section –	19
4-6. Printed Wiring Boards – Main Section –	20
4-7. Schematic Diagram – Main Section (1/2) –	21
4-8. Schematic Diagram – Main Section (2/2) –	22
4-9. Printed Wiring Board – Digital Section (1/2) –	23
4-10. Printed Wiring Board – Digital Section (2/2) –	24
4-11. Schematic Diagram – Digital Section (1/2) –	25
4-12. Schematic Diagram – Digital Section (2/2) –	26
4-13. Printed Wiring Board – Video Section –	27
4-14. Schematic Diagram – Video Section –	27
4-15. Printed Wiring Boards – Display Section –	28
4-16. Schematic Diagram – Display Section –	29
4-17. Printed Wiring Boards – Power Section –	30
4-18. Schematic Diagram – Power Section –	31
4-19. IC Block Diagrams	32

5. EXPLODED VIEWS

5-1. Case Section	37
5-2. Front Panel Section	38
5-3. Chassis Section-1	39
5-4. Chassis Section-2	40

6. ELECTRICAL PARTS LIST 41

SECTION 1 GENERAL

This section is extracted
from instruction manual.

STR-DE497P:

List of button locations and reference pages

How to use pages 50 and 51

Use this page to find the location of buttons that are mentioned in the text.

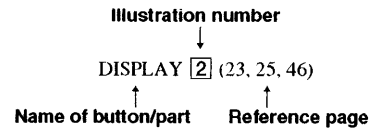

Main unit

ALPHABETICAL ORDER

A-L

A.F.D. (button/indicator) **9** (27, 28, 29, 45)
 CD **25** (20)
 DIMMER **3** (25)
 DISPLAY **2** (23, 25, 46)
 Display **5** (23, 25)
 DVD **27** (20)
 ENTER **13** (17, 34, 46)
 FM MODE **22** (21)
 Input buttons **18** (20, 30, 33, 34, 46)
 INPUT MODE **14** (26, 30)
 IR (receptor) **4** (37, 46)

M-Z

MAIN MENU **17** (17, 30, 32, 34)
 MASTER VOLUME -/+ **12** (19, 20, 45)
 MD/TAPE **26** (20)
 MEMORY **21** (22)
 MOVIE (button/indicator) **10** (28, 45)
 MULTI CH IN* **7** (20)
 MULTI CHANNEL DECODING (indicator)* **6** (20)
 MUSIC (button/indicator) **11** (29, 45)
 PHONES (jack) **23** (20, 26, 45)
 PRESET TUNING -/+ **19** (22, 48)
 TUNER FM/AM **24** (20, 21, 34)
 TUNING -/+ **20** (21, 48)
 VIDEO 1 **29** (20)
 VIDEO 2 **28** (20)

NUMBERS AND SYMBOLS

2CH (button/indicator) **8** (27, 29, 31)
 +/- **15** (17, 30, 32, 34)
 </> **16** (17, 30, 32, 34)
 I/⏻ (power) **1** (17, 22, 46, 48)

* Models of area code CEL, CEK only.

STR-DE497P:

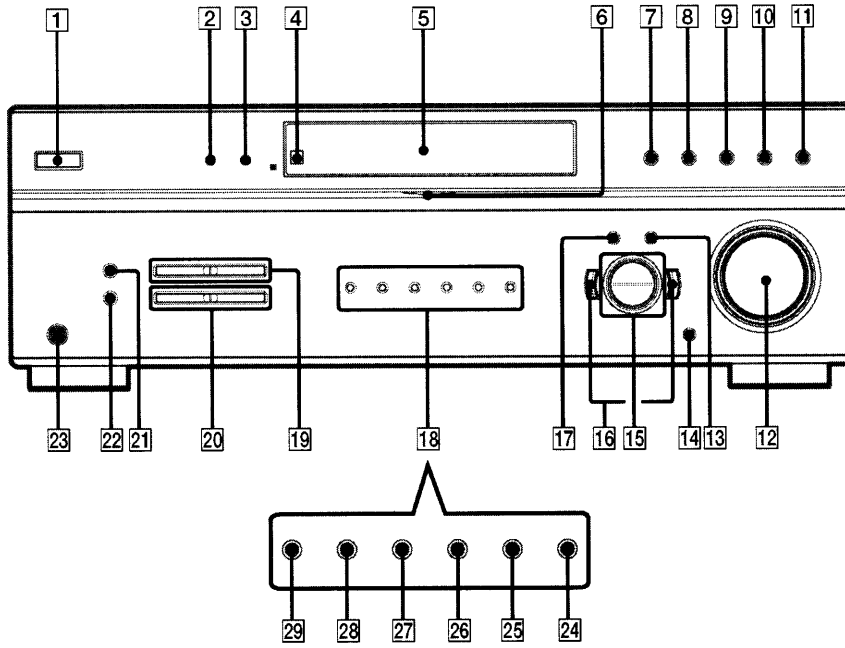

Additional Information

STR-K4800P/K5800P:

List of button locations and reference pages

How to use pages 46 and 47

Use this page to find the location of buttons that are mentioned in the text.

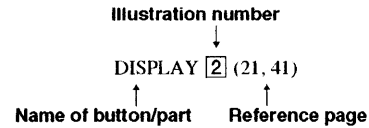

Main unit

ALPHABETICAL ORDER

A - L

A.F.D. (button/indicator) [8] (23, 24, 25, 40)
 CD [24] (18)
 DIMMER [3] (21)
 DISPLAY [2] (21, 41)
 Display [5] (21)
 DVD [26] (18)
 ENTER [12] (14, 30)
 FM MODE [21] (19)
 Input buttons [17] (18, 26, 29, 30, 41)
 INPUT MODE [13] (22, 26)
 IR (receptor) [4] (32, 41)

M - Z

MAIN MENU [16] (15, 26, 28, 30)
 MASTER VOLUME \pm [11] (17, 18, 40)
 MD/TAPE [25] (18)
 MEMORY [20] (20)
 MOVIE (button/indicator) [9] (24, 40)
 MULTICHANNEL DECODING (indicator) [6] (18)
 MUSIC (button/indicator) [10] (25, 40)
 PHONES (jack) [22] (18, 22, 40)
 PRESET TUNING \pm [18] (20, 43)
 TUNER FM/AM [23] (18, 19, 30)
 TUNING \pm [19] (19, 43)
 VIDEO 1 [28] (18)
 VIDEO 2 [27] (18)

NUMBERS AND SYMBOLS

2CH (button/indicator) [7] (23, 25, 27)
 \pm [14] (15, 26, 28, 30)
 $\langle \rangle$ [15] (15, 26, 28, 30)
 I/O (power) [1] (14, 15, 43)

STR-K4800P/K5800P:

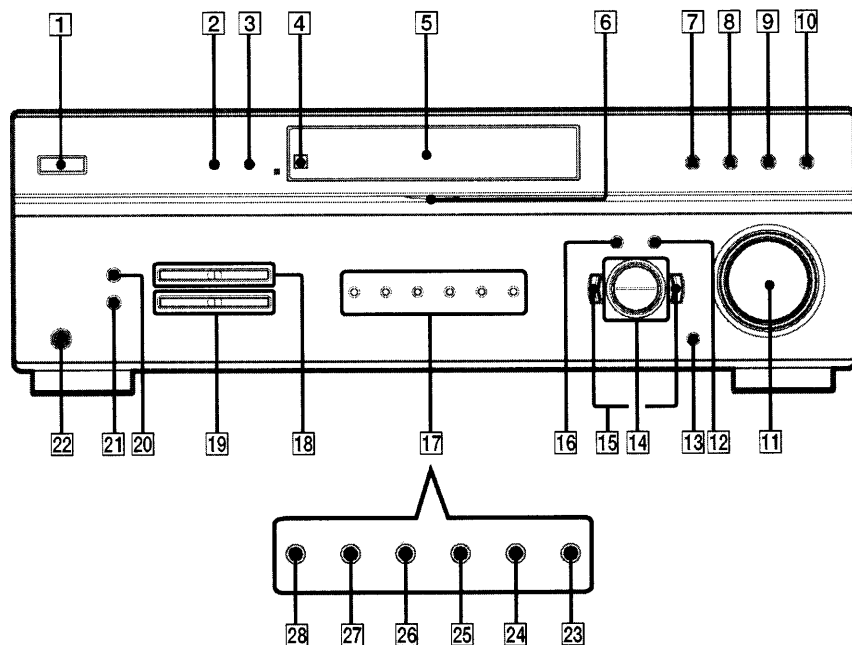

Additional Information

Operations Using the Remote RM-PP760

You can use the remote RM-PP760 to operate the components in your system.

Before you use your remote

Inserting batteries into the remote

Insert R6 (size-AA) batteries with the + and - properly oriented in the battery compartment. When using the remote, point it at the remote sensor  on the receiver.

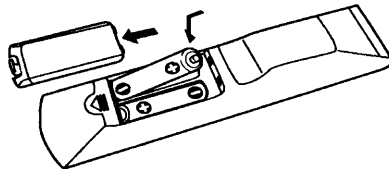

Tip

Under normal conditions, the batteries should last for about 6 months. When the remote no longer operates the receiver, replace all batteries with new ones.

Notes

- Do not leave the remote in an extremely hot or humid place.
- Do not use a new battery with an old one.
- Do not expose the remote sensor to direct sunlight or lighting apparatuses. Doing so may cause a malfunction.
- If you don't use the remote for an extended period of time, remove the batteries to avoid possible damage from battery leakage and corrosion.

Remote button description

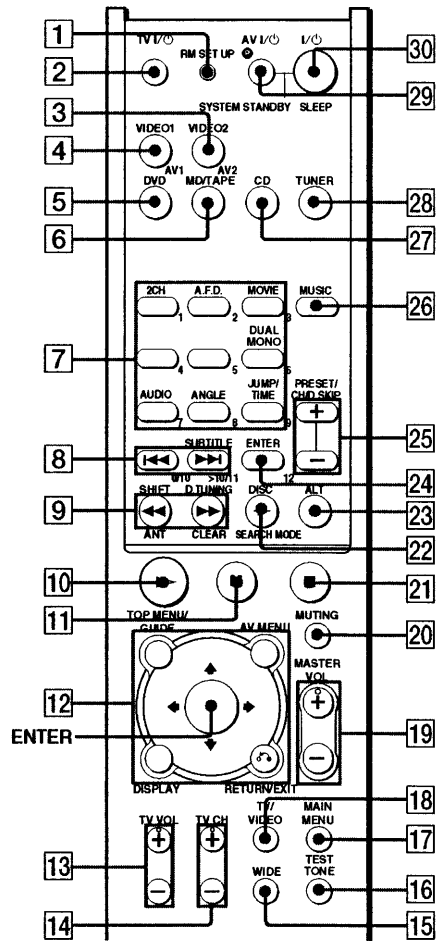

The tables below show the settings of each button.

Remote Button	Operations	Function
A.F.D. 	Receiver	Selects the decoding mode for audio sound.

SECTION 2 DISASSEMBLY

Note : This set can be disassemble according to the following sequence.

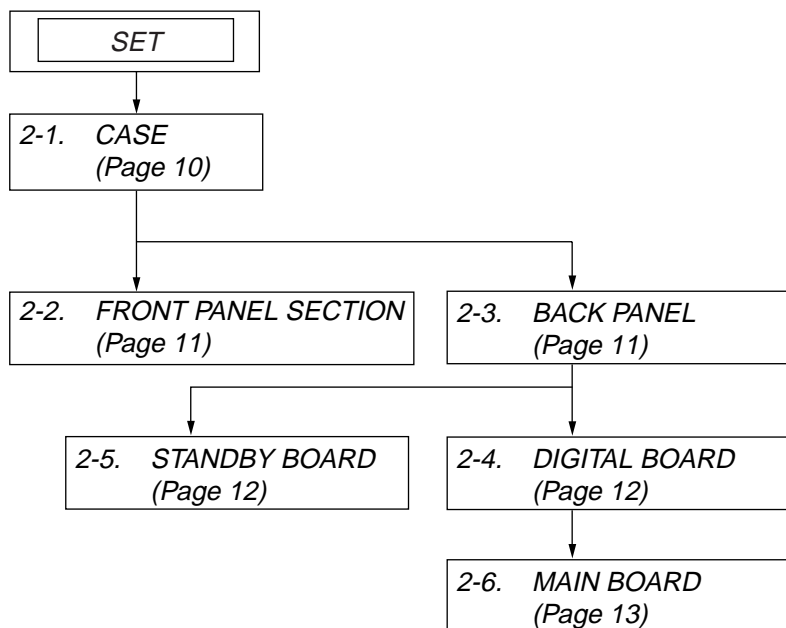

Note : Follow the disassembly procedure in the numerical order given.

2-1. CASE

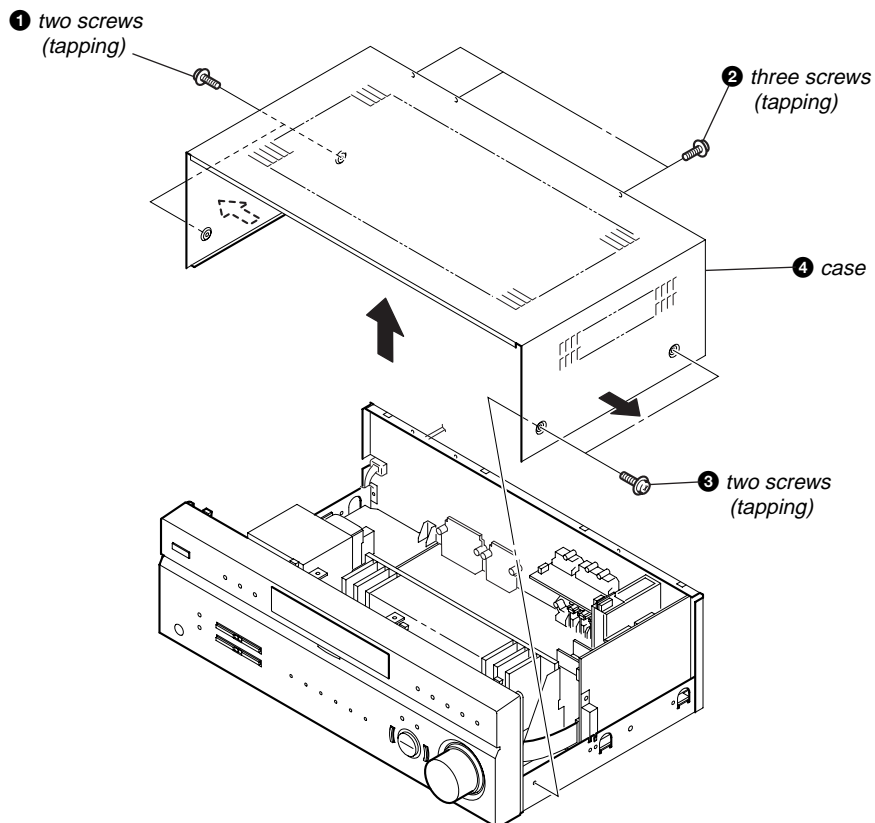

2-2. FRONT PANEL SECTION

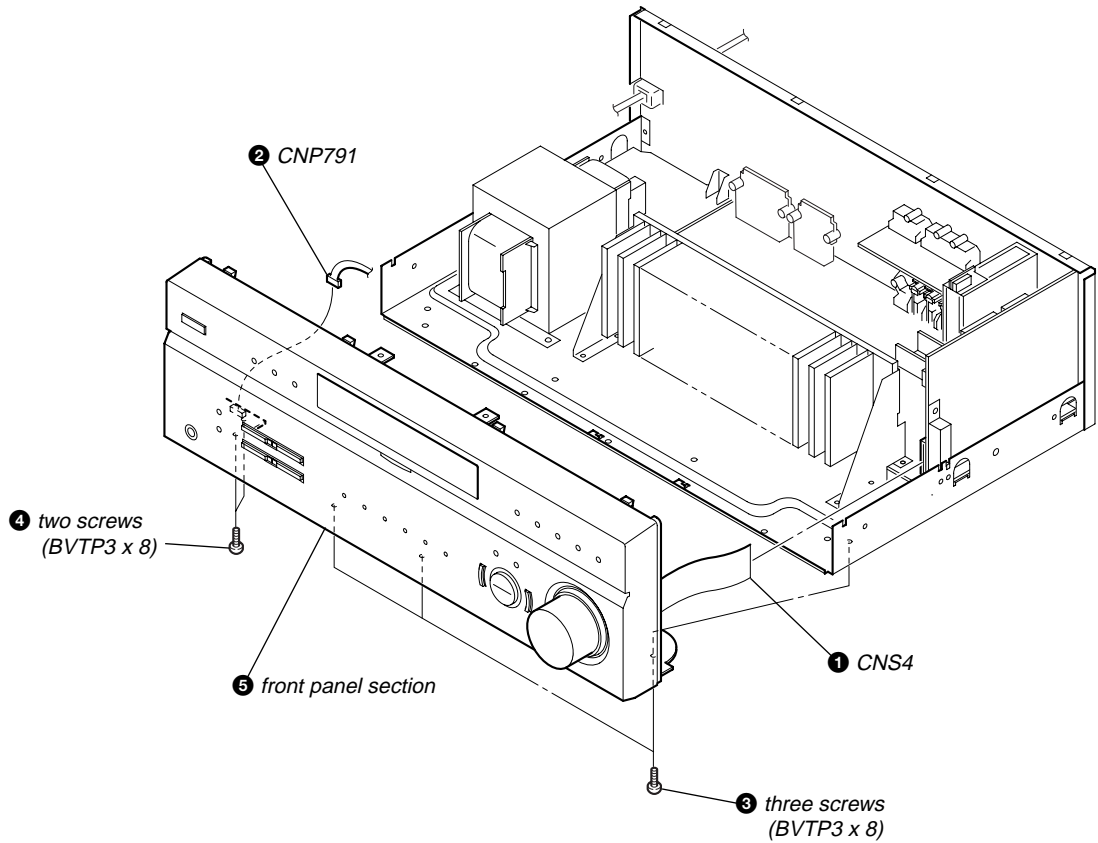

2-3. BACK PANEL

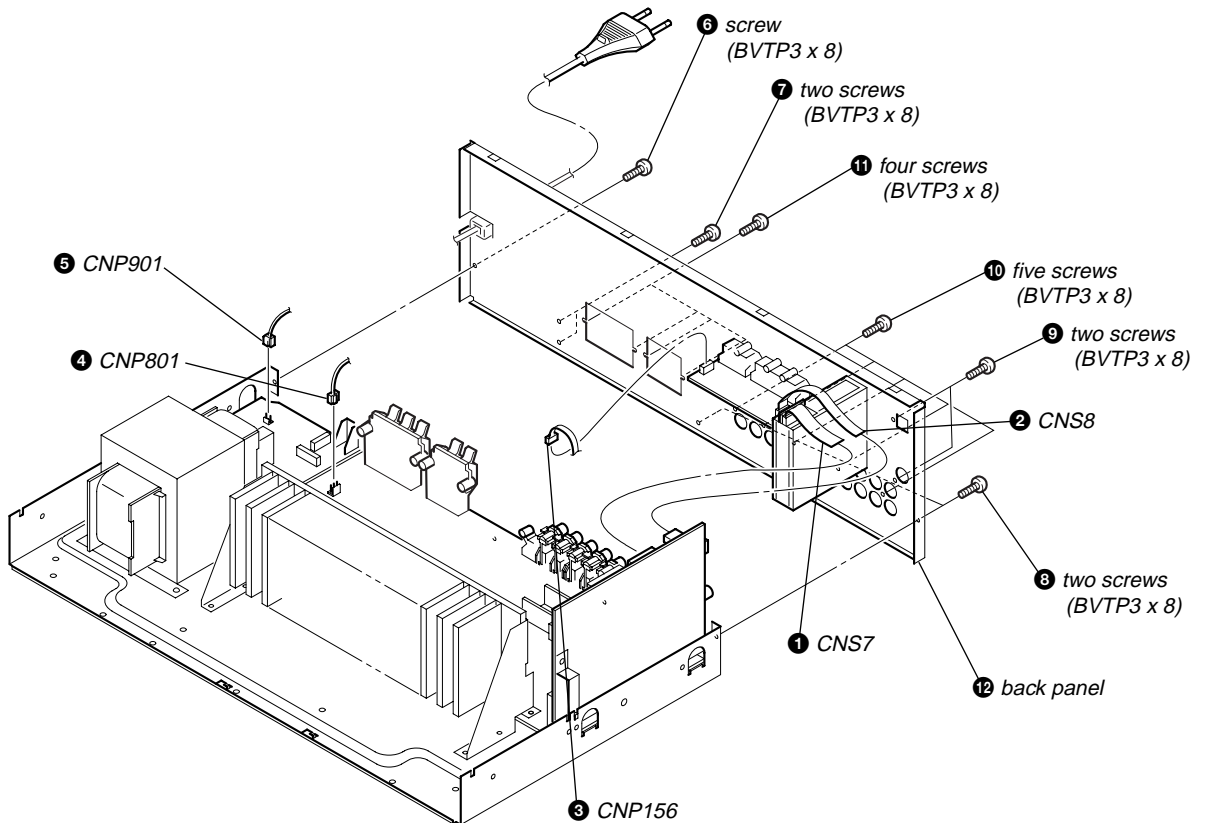

2-4. DIGITAL BOARD

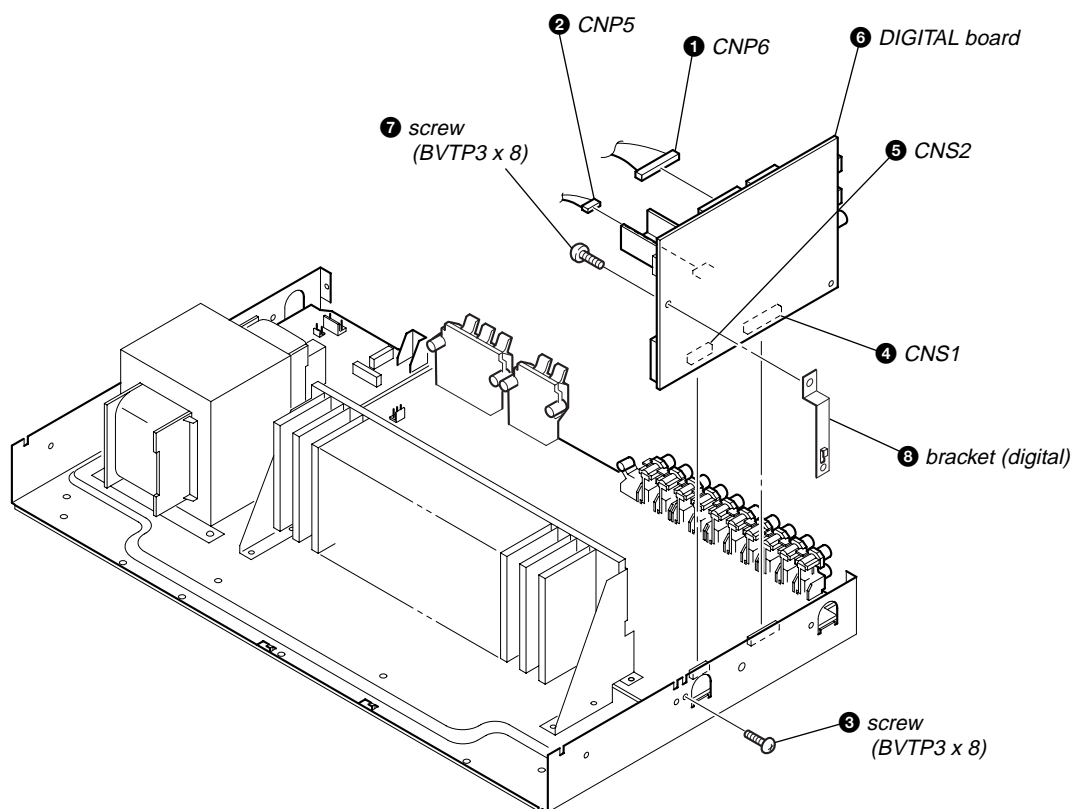

2-5. STANDBY BOARD

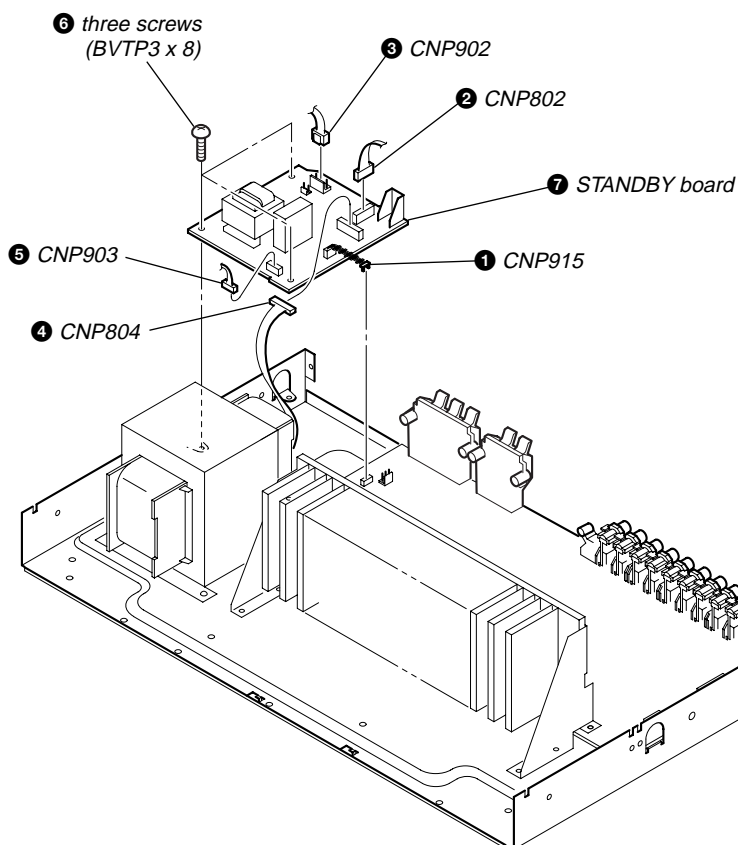

2-6. MAIN BOARD

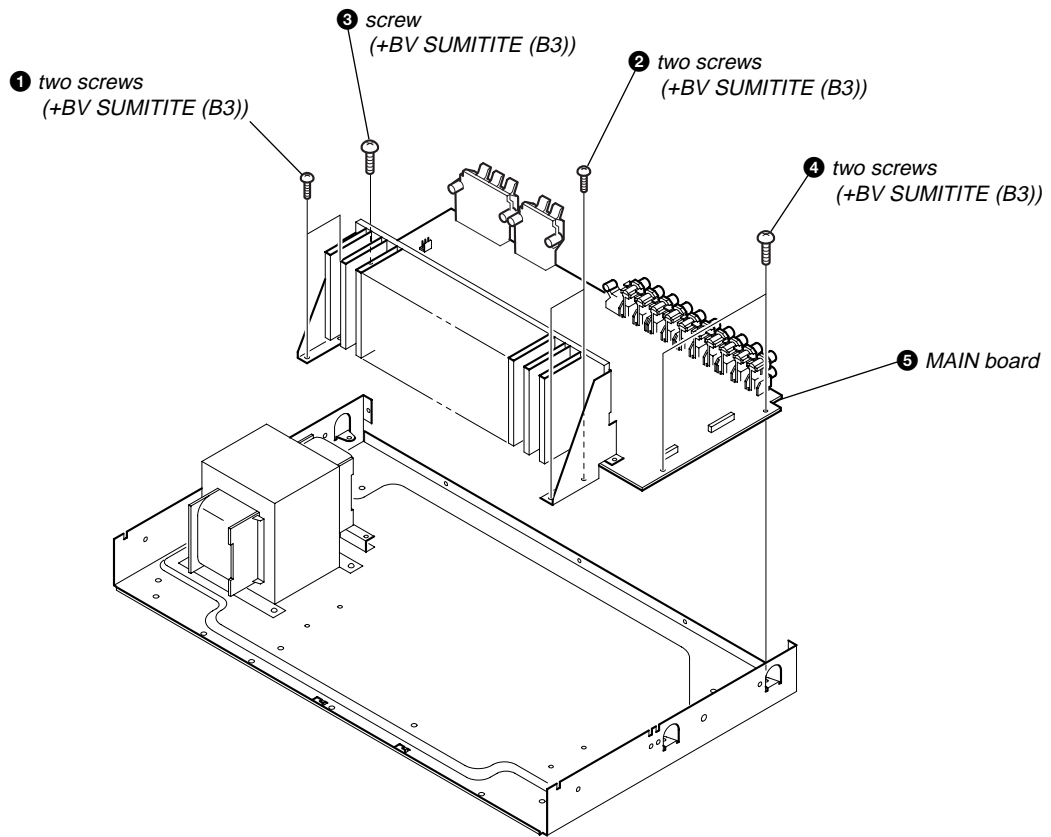

SECTION 3 TEST MODE

FACTORY PRESET MODE

* All preset contents are reset to the default setting.

* Procedure:

While depressing the **MAIN MENU** and the **PRESET TUNING** buttons simultaneously, press the **I/⏻** button to turn on the main power.

The message "FACTORY" appears for a moment and the present contents are reset to the default values.

AM CHANNEL STEP 9 kHz/10 kHz SELECTION MODE (US, Canadian model only)

* Either the 9 kHz step or 10 kHz step can be selected for the AM channel step.

* Procedure:

Press the **TUNER FM/AM** button to set AM and press the **I/⏻** button to turn off the main power.

While depressing the **TUNING +** button or the **PRESET TUNING +** button, press the **I/⏻** button to turn on the main power.

Either the message "9k STEP" or "10k STEP" appears for a moment and select the desired step.

SPEAKER SIZE SELECTION MODE

* Either the normal speaker or micro satellite speaker can be selected.

* Procedure:

While depressing the **DIMMER** button, press the **I/⏻** button to turn on the main power.

Either the message "NORM. SP." or "MICRO SP." appears for a moment and select the desired speaker size.

VACUUM FLUORESCENT DISPLAY TEST MODE

* All fluorescent segments are tested.

When this test is activated, all segments light on at the same time, then each segment lights on one after another.

* Procedure:

While depressing the **MOVIE** and the **▷** buttons simultaneously, press the **I/⏻** button to turn on the main power.

1. ALL segments light on.

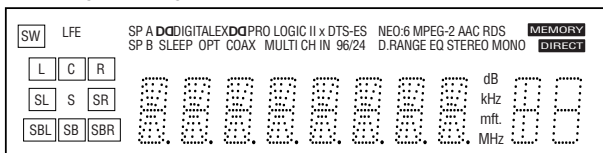

2CH, **A.F.D.**, **MOVIE**, **MUSIC** and **MULTI CHANNEL DECODING** LED light on.

2. Press the **VIDEO 1** button, confirm display.

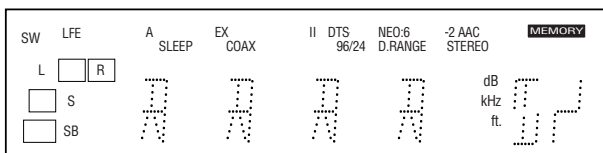

A.F.D. and **MUSIC** LED light on.

3. Press the **VIDEO 1** button, confirm display.

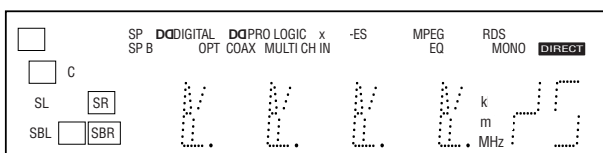

2CH, **MOVIE** and **MULTI CHANNEL DECODING** LED light on.

4. Press the **VIDEO 1** button, all segments and all LEDs light off.

5. Every pressing the **VIDEO 1** button turns on each segment and LED one after another in the same order.

(Not only the **VIDEO 1** button, but also the other buttons such as **VIDEO 2**, **DVD**, **MD/TAPE**, **CD** and **TUNER FM/AM** can be used.)

SOUND FIELD CLEAR MODE

* The preset sound field is cleared when this mode is activated.

Use this mode before returning the product to clients upon completion of repair.

* Procedure:

While depressing the **2CH** button, press the **I/⏻** button to turn on the main power.

The message "SF. CLR." appears for a moment and initialization is performed.

SOFTWARE VERSION DISPLAY MODE

* The software version is displayed.

* Procedure:

While depressing the **FM MODE** and the **DISPLAY** buttons simultaneously, press the **I/⏻** button to turn on the main power.

The model name, destination and the software version are displayed for a moment.

KEY CHECK MODE

* Button check

* Procedure:

While depressing the **TUNER FM/AM** and the **A.F.D.** buttons simultaneously, press the **I/⏻** button to turn on the main power. Either the message "REST 26" (STR-DE497P) or "REST 25" (STR-K4800P/K5800P) appears.

Every pressing of any button other than the **I/⏻** counts down the buttons. The buttons which are already counted once are not counted again. When all buttons are pressed "REST 00" appears.

AUTOBETICAL MODE (AEP, UK model only)

* When this mode is used, the receiver scans the broadcasts that can be received by the tuner, and sets up the broadcasts.

Be sure to start scanning after connecting the antenna.

* Procedure:

Check that the antenna is connected.

While depressing the **MEMORY** button, press the **I/⏻** button to turn on the main power.

The message "AUTO-BETICAL SELECT" appears for a moment and the receiver starts scanning.

COMMAND MODE SELECTION MODE

* The command mode (AV1 or AV2) of the remote commander can be selected.

* Procedure:

While depressing the **ENTER** button, press the **I/⏻** button to turn on the main power.

Either the message "C.MODE.AV 1" or "C.MODE.AV 2" appears for a moment and select the desired mode.

SECTION 4 DIAGRAMS

4-1. CIRCUIT BOARDS LOCATION

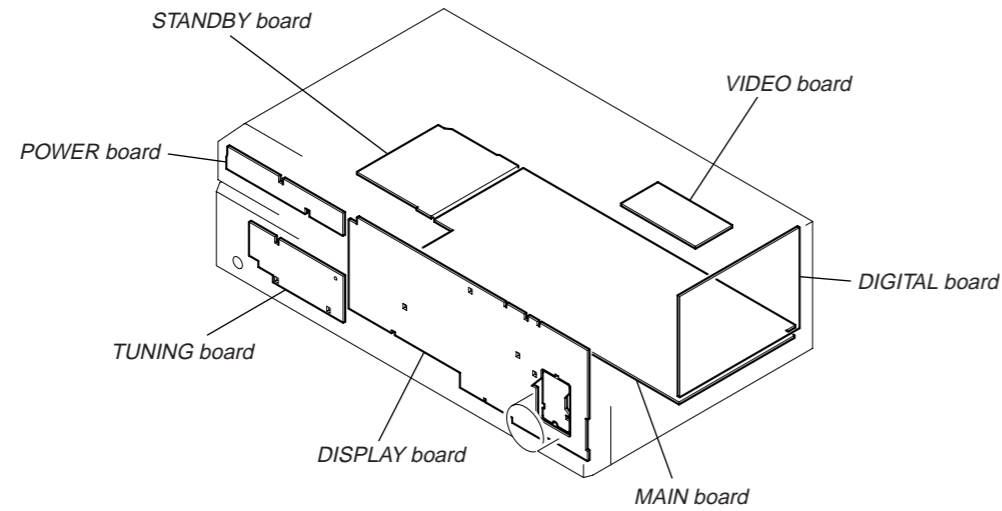

THIS NOTE IS COMMON FOR PRINTED WIRING BOARDS AND SCHEMATIC DIAGRAMS.
(In addition to this, the necessary note is printed in each block.)

for schematic diagram:

- All capacitors are in μF unless otherwise noted. (p: pF) 50 WV or less are not indicated except for electrolytics and tantalums.
- All resistors are in Ω and $1/4\text{W}$ or less unless otherwise specified.
- Δ : internal component.
- : nonflammable resistor.
- : fusible resistor.
- : panel designation.

Note:
The components identified by mark Δ or dotted line with mark Δ are critical for safety. Replace only with part number specified.

Note:
Les composants identifiés par une marque Δ sont critiques pour la sécurité. Ne les remplacer que par une pièce portant le numéro spécifié.

- : B+ Line.
- : B- Line.
- Voltage and waveforms are dc with respect to ground under no-signal (detuned) conditions.
no mark : FM
- Voltages are taken with a VOM (Input impedance 10 M Ω). Voltage variations may be noted due to normal production tolerances.
- Waveforms are taken with a oscilloscope. Voltage variations may be noted due to normal production tolerances.
- Circled numbers refer to waveforms.
- Signal path.
 : TUNER (FM/AM)
 : VIDEO (AUDIO)
 : VIDEO
 : CD (ANALOG)
 : CD (DIGITAL)
- Abbreviation
CND : Canadian model.

for printed wiring boards:

- : parts extracted from the component side.
- Δ : internal component.
- : Pattern from the side which enables seeing.

Caution:
Pattern face side: Parts on the pattern face side seen from the pattern face are indicated.
(Side B)
Parts face side: Parts on the parts face side seen from the parts face are indicated.
(Side A)

- Abbreviation
CND : Canadian model.

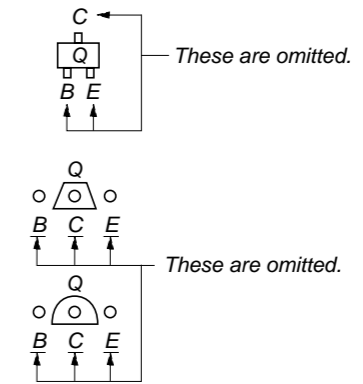

• Waveforms (DIGITAL Board)

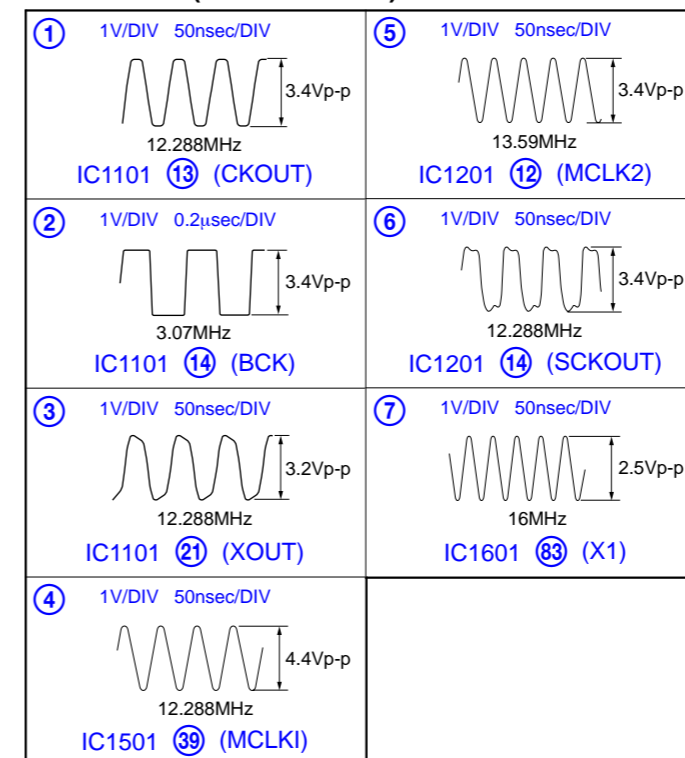

4-2. BLOCK DIAGRAM — TUNER/AUDIO SECTION —

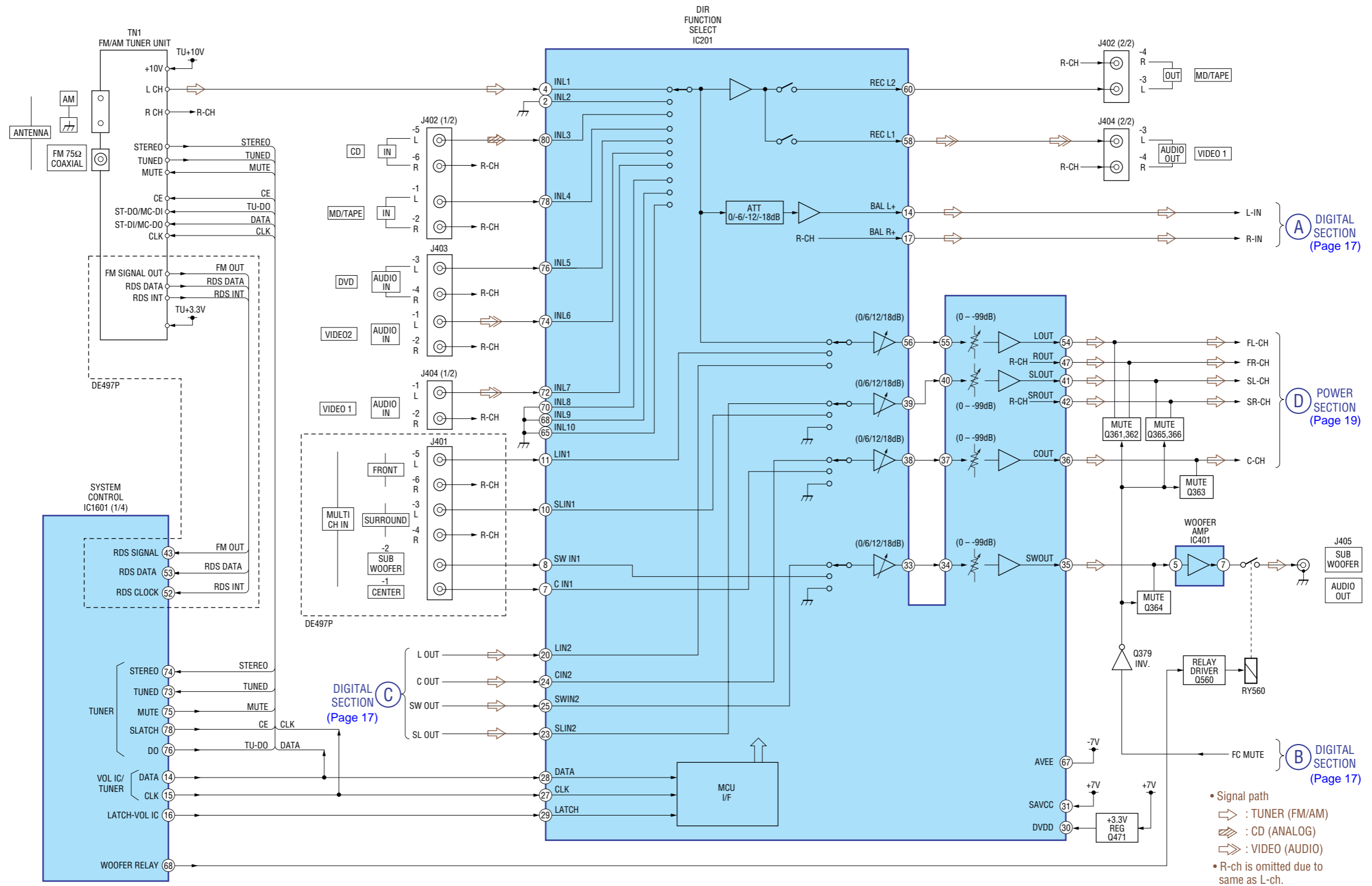

4-3. BLOCK DIAGRAM — DIGITAL SECTION —

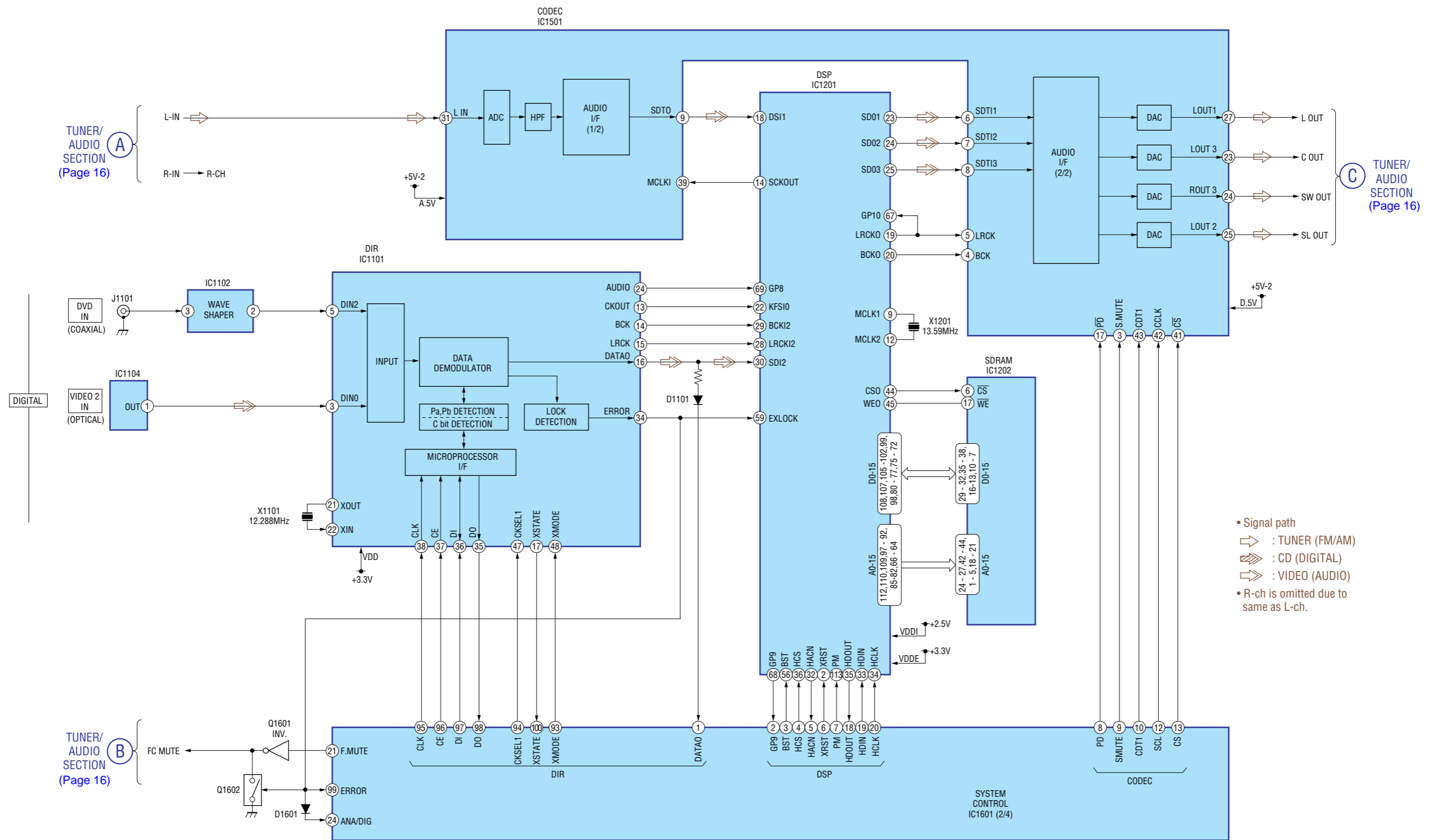

4-4. BLOCK DIAGRAM — VIDEO/DISPLAY SECTION —

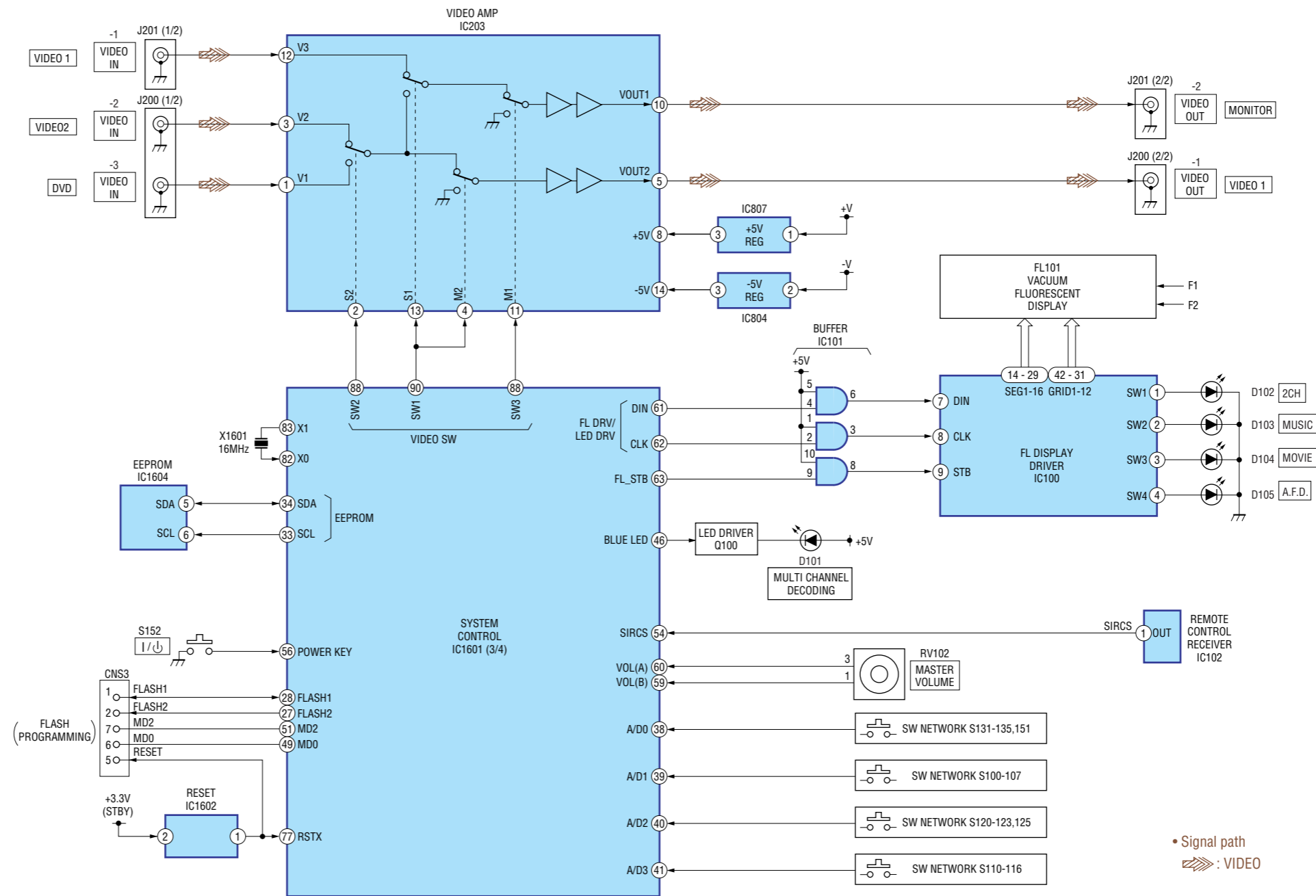

4-5. BLOCK DIAGRAM — POWER SECTION —

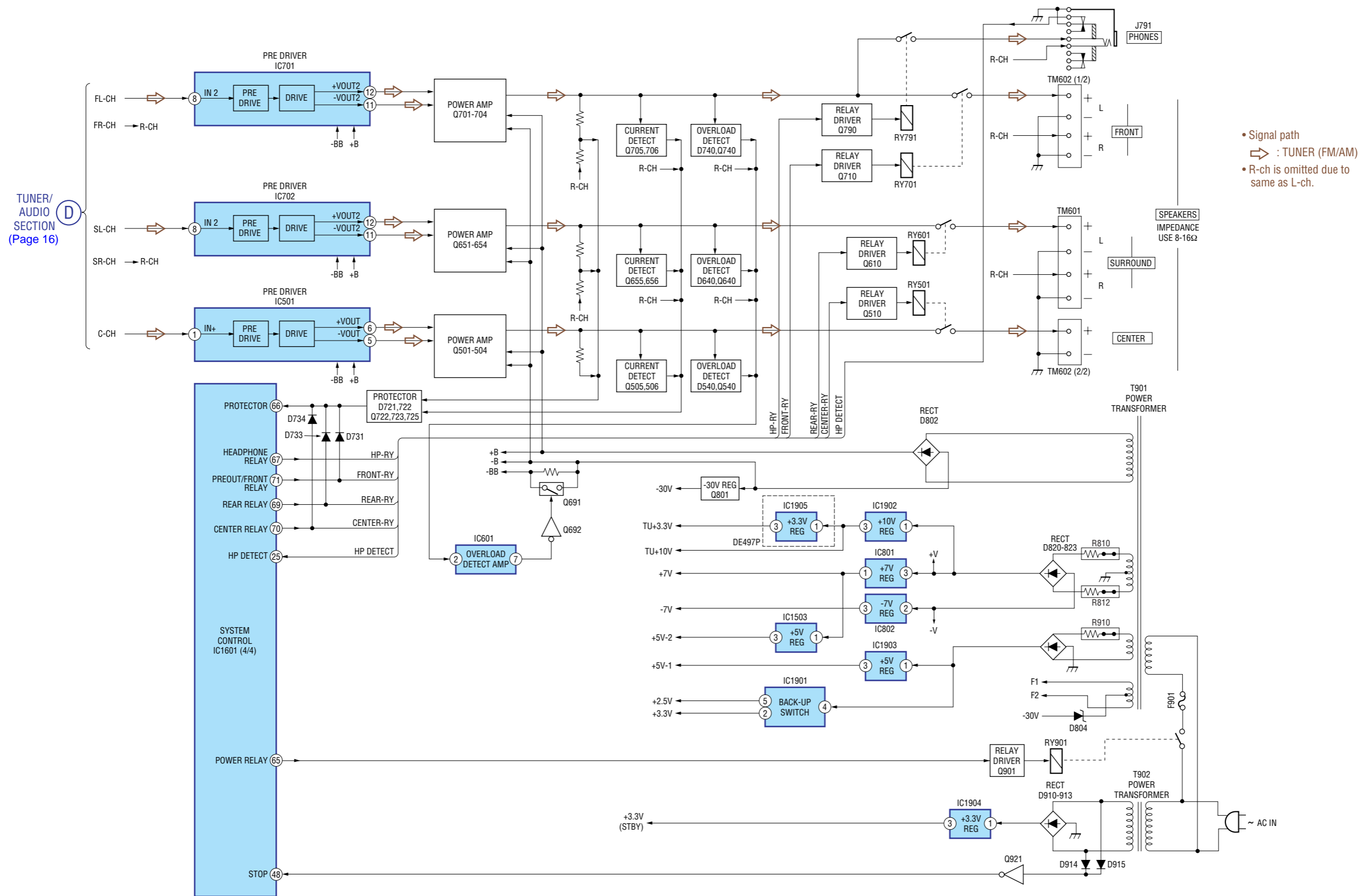

4-6. PRINTED WIRING BOARDS — MAIN SECTION — • Refer to page 15 for Circuit Boards Location and Common Note on Printed Wiring Boards.

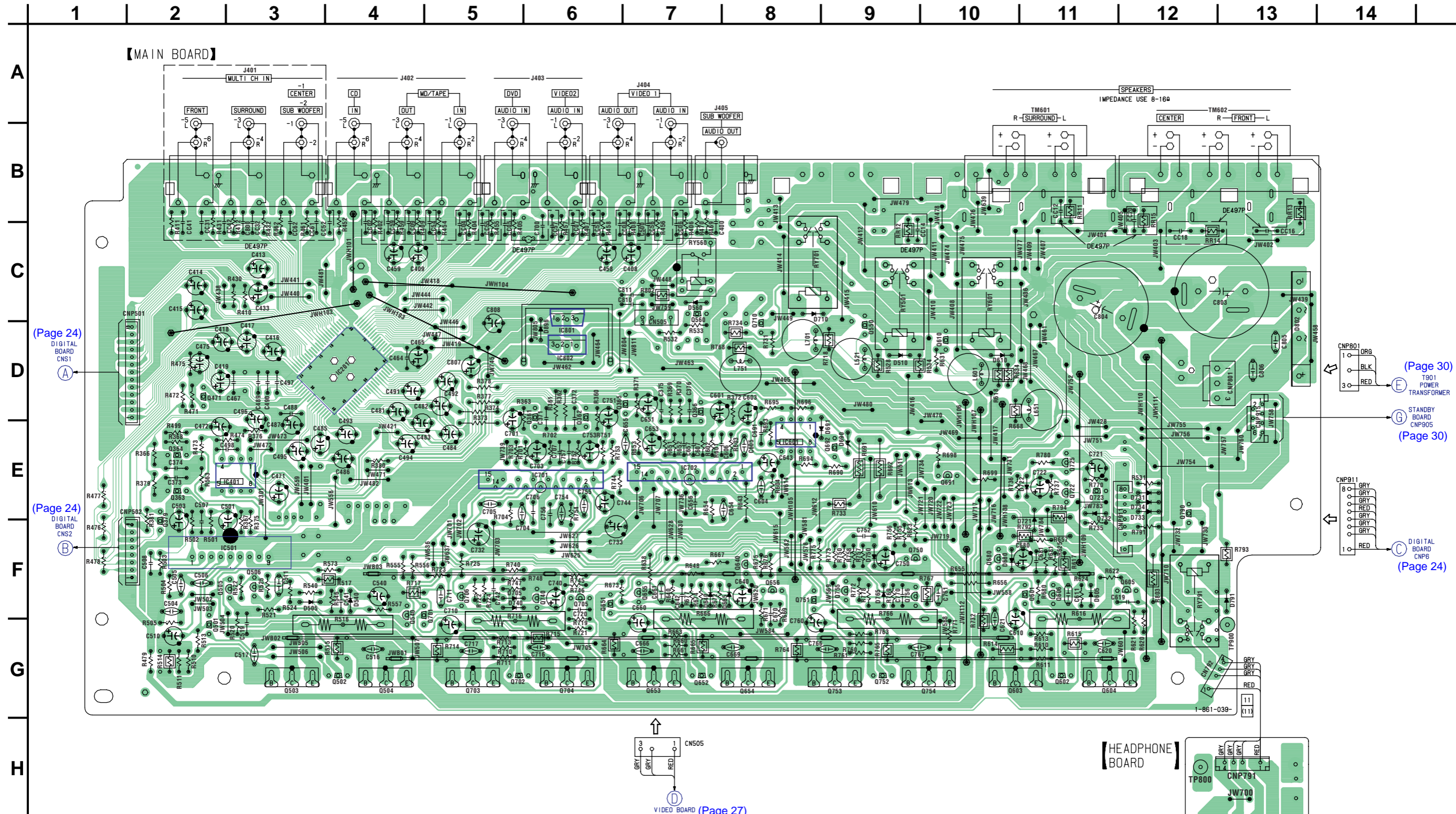

(Page 24)
DIGITAL BOARD
CNS1

(Page 24)
DIGITAL BOARD
CNS2

(Page 30)
T901
POWER
TRANSFORMER

(Page 30)
STANDBY
BOARD
CNP905

(Page 24)
DIGITAL BOARD
CNP6

(Page 27)
VIDEO BOARD
CNP156

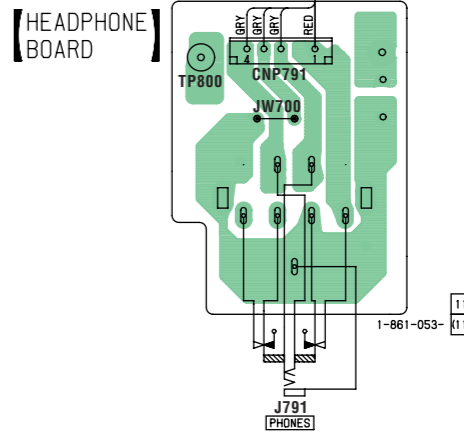

• Semiconductor Location

Ref. No.	Location	Ref. No.	Location	Ref. No.	Location	Ref. No.	Location	Ref. No.	Location	Ref. No.	Location	Ref. No.	Location
D505	G-3	D721	F-10	IC201	D-4	Q365	E-6	Q601	F-10	Q656	F-8	Q725	E-11
D510	D-9	D722	E-10	IC401	E-3	Q366	E-7	Q602	G-11	Q680	F-10	Q740	G-6
D540	G-4	D731	F-12	IC501	F-2	Q379	F-2	Q603	G-10	Q691	E-10	Q750	F-9
D560	D-7	D732	F-11	IC601	E-8	Q471	E-2	Q604	G-11	Q692	E-8	Q751	G-8
D605	F-11	D733	F-12	IC701	E-6	Q501	G-2	Q605	F-11	Q701	G-4	Q752	G-9
D610	D-10	D734	F-12	IC702	E-7	Q502	G-4	Q606	F-11	Q702	G-5	Q753	G-9
D640	G-7	D740	G-5	IC801	D-6	Q503	G-3	Q610	F-11	Q703	G-5	Q754	G-9
D665	G-7	D750	F-9	IC802	D-6	Q504	G-4	Q640	F-8	Q704	G-6	Q755	F-9
D680	F-10	D765	G-9			Q505	F-3	Q651	G-6	Q705	G-6	Q756	F-12
D690	E-9	D791	G-12	Q361	E-6	Q506	F-3	Q652	G-7	Q706	G-5	Q790	F-12
D691	E-8	D802	D-13	Q362	E-6	Q540	G-4	Q653	G-7	Q710	D-8		
D705	F-5	D896	D-6	Q363	E-2	Q550	D-9	Q654	G-8	Q722	E-11		
D710	D-8			Q364	E-2	Q560	D-7	Q655	F-7	Q723	E-11		

4-8. SCHEMATIC DIAGRAM — MAIN SECTION (2/2) — • Refer to page 15 for Common Note on Schematic Diagram and page 32 for IC Block Diagrams.

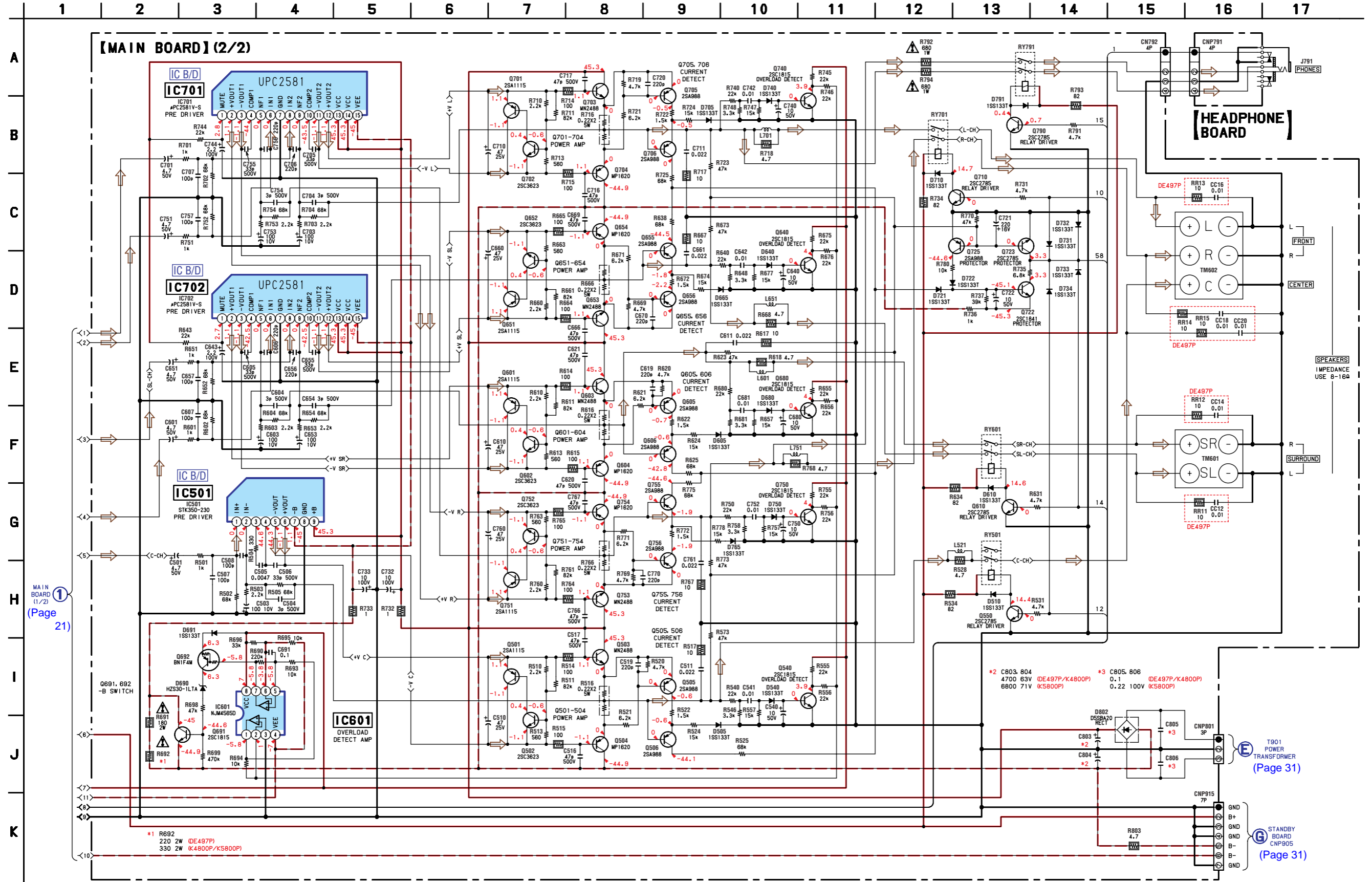

MAIN BOARD (1/2) (Page 21)

*1 R692 220 2W (DE497P) 330 2W (K4800P/K5800P)

*2 C803, 804 4700 83V (DE497P/K4800P) 8800 71V (K5800P) *3 C805, 806 0.1 (DE497P/K4800P) 0.22 100V (K5800P)

T901 POWER TRANSFORMER (Page 31)

STANDBY BOARD CNP905 (Page 31)

The components identified by mark Δ or dotted line with mark Δ are critical for the safety. Replace only with part number specified.

Les composants identifiés par une marque Δ sont critiques pour la sécurité. Ne les remplacer que par une pièce portant le numéro spécifié.

4-9. PRINTED WIRING BOARD — DIGITAL SECTION (1/2) — • Refer to page 15 for Circuit Boards Location and Common Note on Printed Wiring Boards.

13 | 12 | 11 | 10 | 9 | 8 | 7 | 6 | 5 | 4 | 3 | 2 | 1

A
B
C
D
E
F
G
H
I
J

【DIGITAL BOARD】(SIDE A)

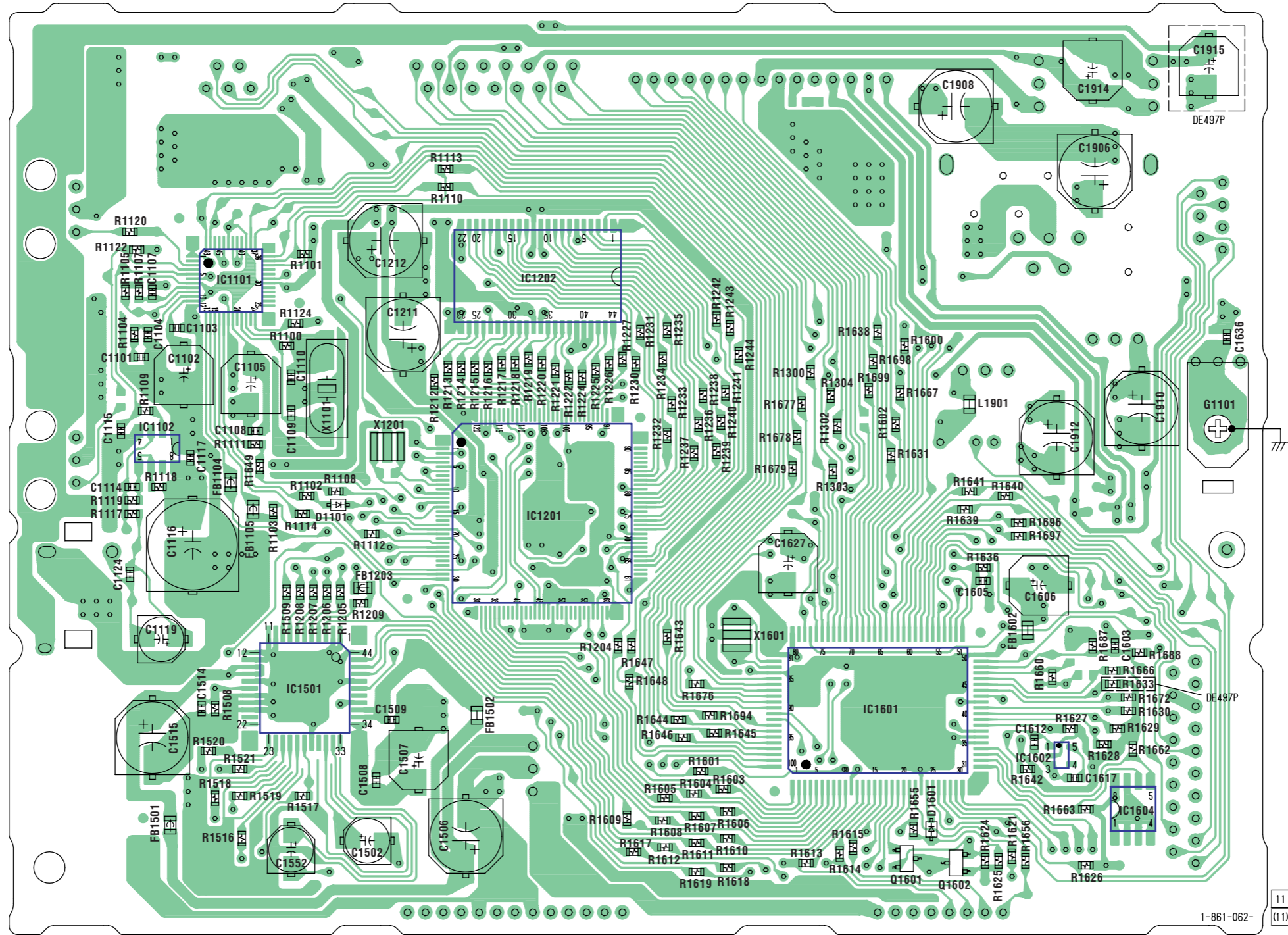

• Semiconductor Location (Side A)

Ref. No.	Location
D1101	F-9
D1601	I-4
IC1101	D-10
IC1102	F-11
IC1201	F-8
IC1501	H-9
IC1601	H-5
IC1602	H-3
IC1604	I-3
Q1601	I-5
Q1602	I-4

11
1-861-062- (11)

4-10. PRINTED WIRING BOARD — DIGITAL SECTION (2/2) — • Refer to page 15 for Circuit Boards Location and Common Note on Printed Wiring Boards.

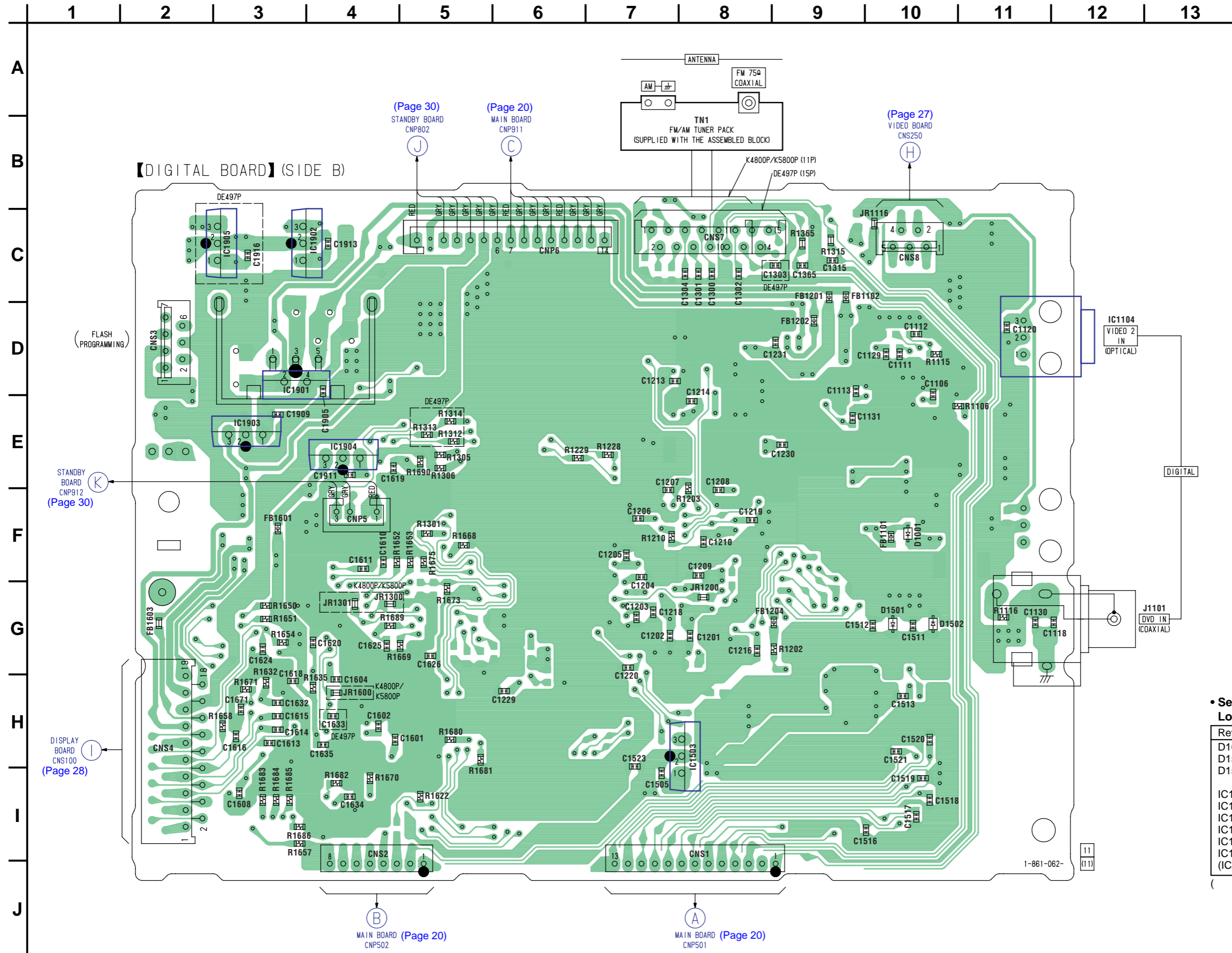

• Semiconductor Location (Side B)

Ref. No.	Location
D1001	F-10
D1501	G-10
D1502	G-10
IC1104	D-11
IC1503	H-8
IC1901	D-3
IC1902	C-4
IC1903	E-3
IC1904	E-4
IC1905	C-3

(): STR-DE497P only

4-11. SCHEMATIC DIAGRAM — DIGITAL SECTION (1/2) — • Refer to page 15 for Common Note on Schematic Diagram and Waveforms and page 32 for IC Block Diagrams and page 33 for IC Pin Descriptions.

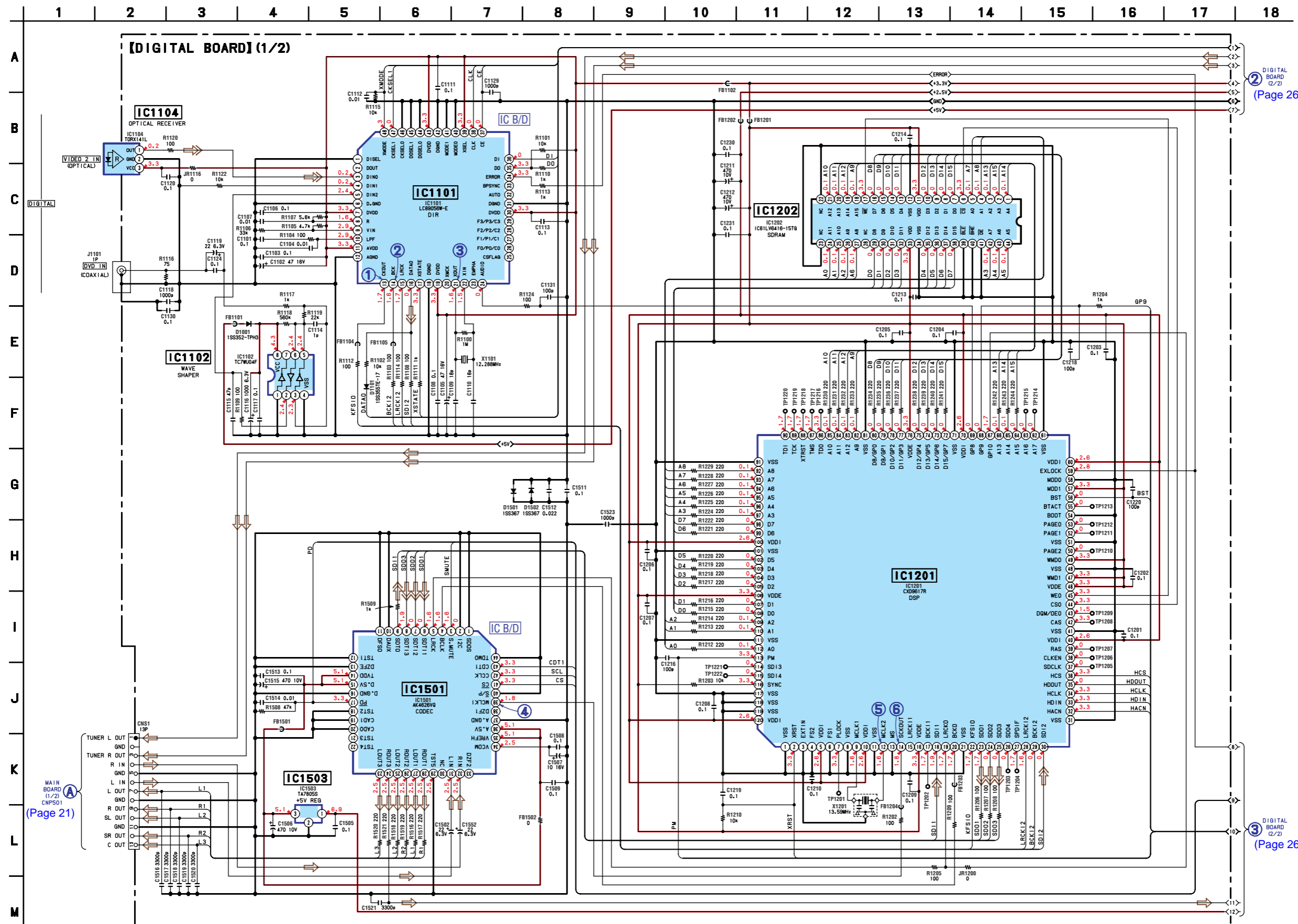

DIGITAL BOARD (2/2) (Page 26)

DIGITAL BOARD (2/2) (Page 26)

4-12. SCHEMATIC DIAGRAM — DIGITAL SECTION (2/2) — • Refer to page 15 for Common Note on Schematic Diagram and Waveforms and page 35 for IC Pin Descriptions.

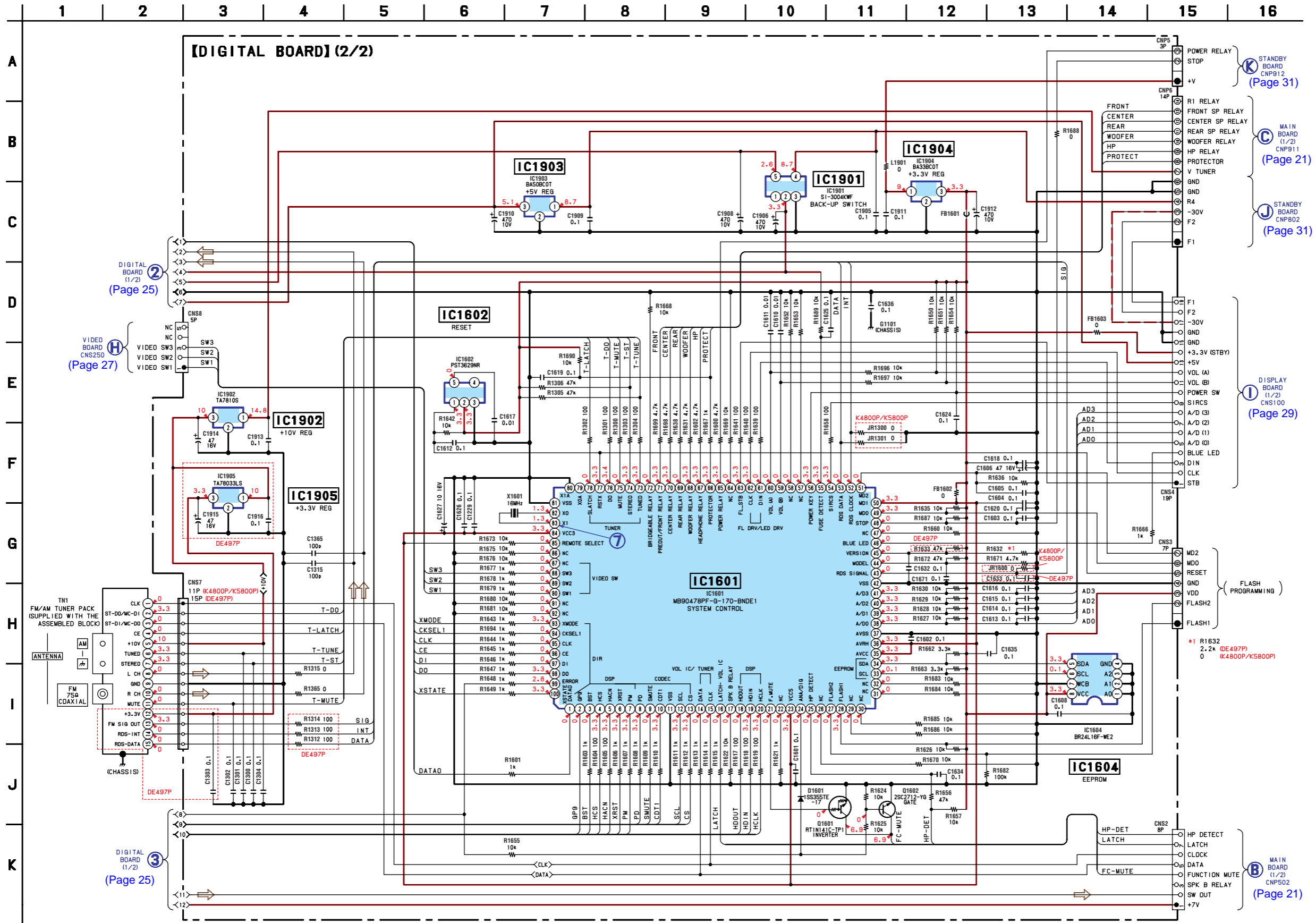

4-13. PRINTED WIRING BOARD — VIDEO SECTION — • Refer to page 15 for Circuit Boards Location and Common Note on Printed Wiring Boards.

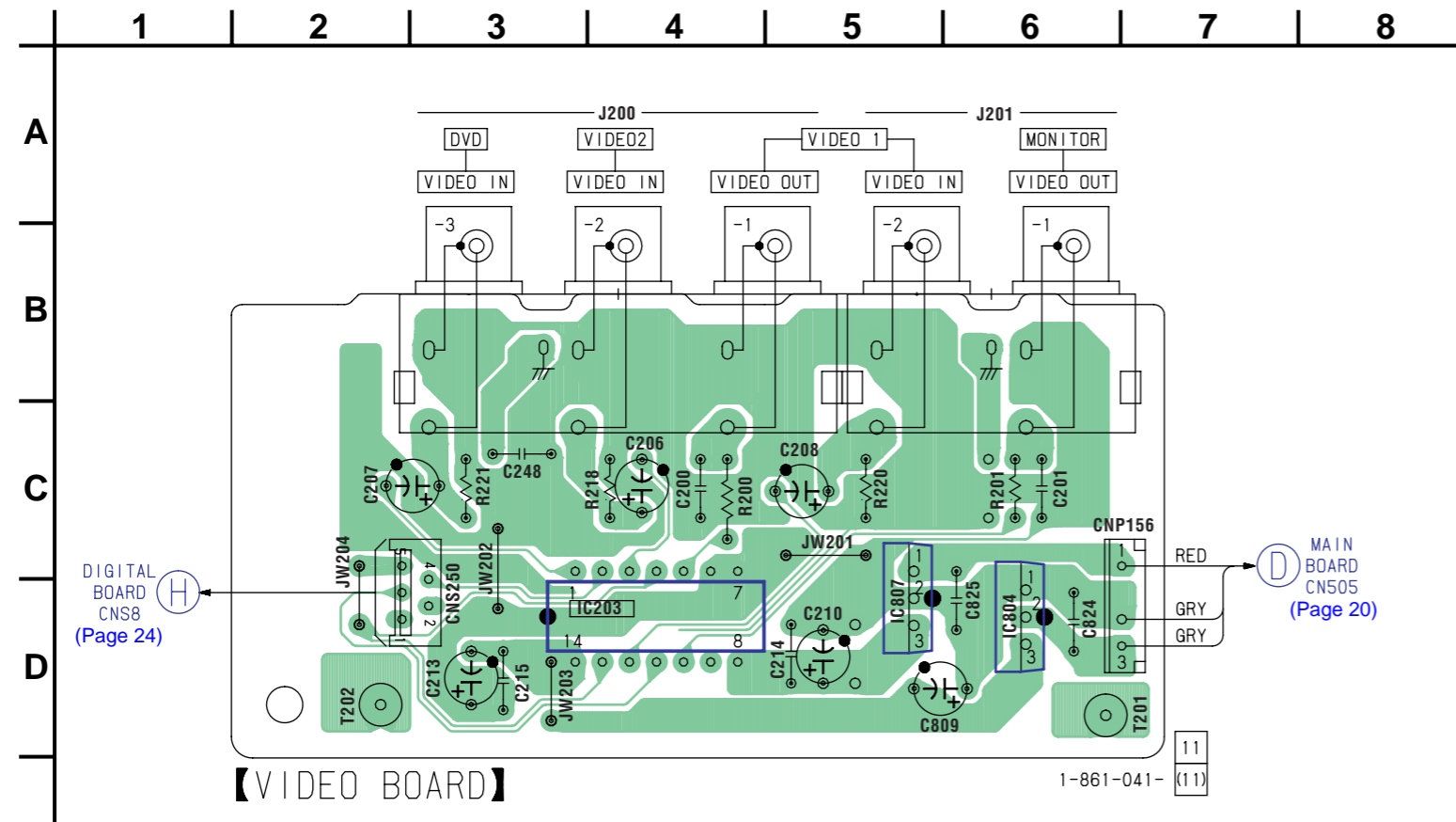

4-14. SCHEMATIC DIAGRAM — VIDEO SECTION — • Refer to page 15 for Common Note on Schematic Diagram and page 32 for IC Block Diagrams.

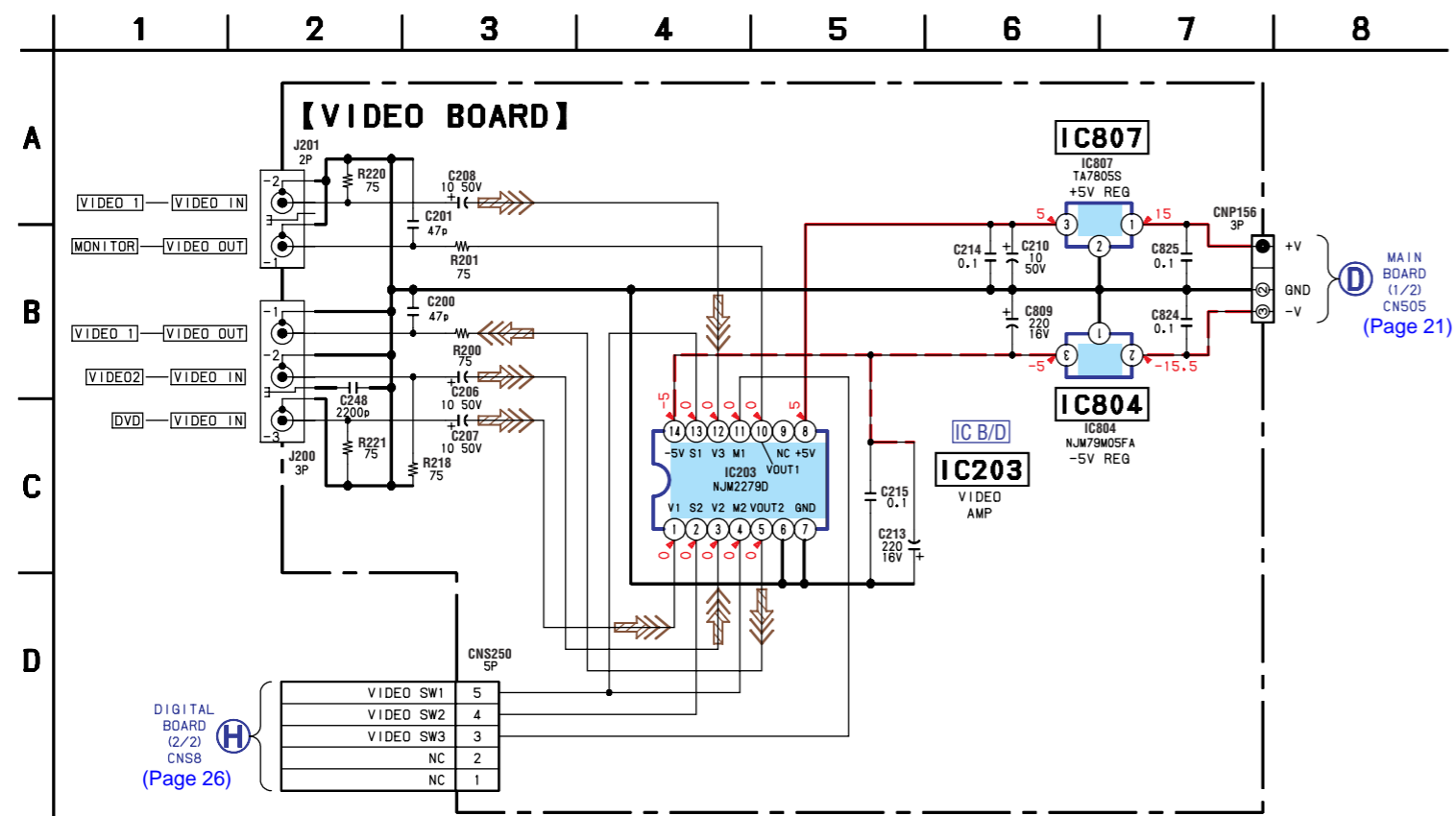

4-15. PRINTED WIRING BOARDS — DISPLAY SECTION — • Refer to page 15 for Circuit Boards Location and Common Note on Printed Wiring Boards.

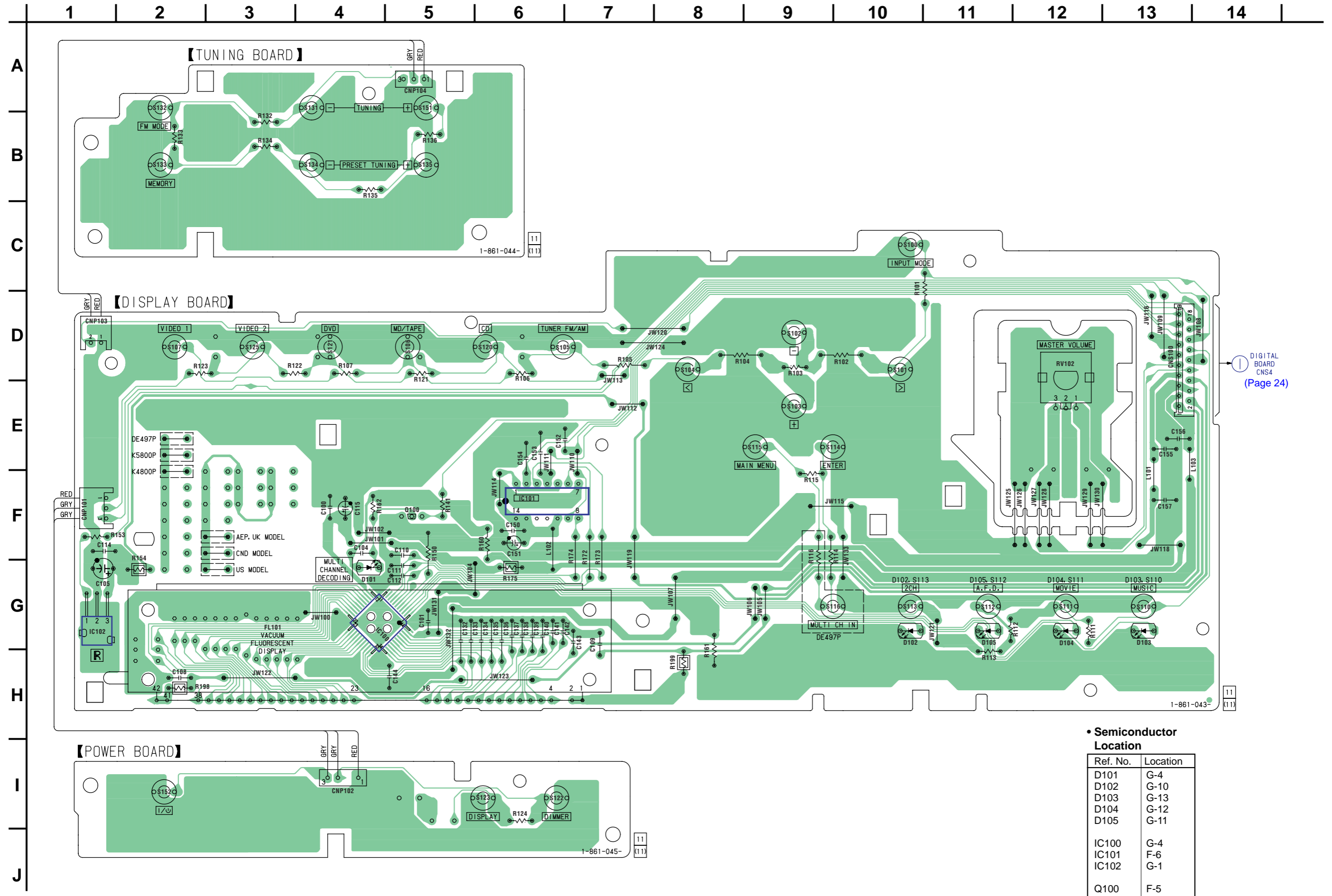

• Semiconductor Location

Ref. No.	Location
D101	G-4
D102	G-10
D103	G-13
D104	G-12
D105	G-11
IC100	G-4
IC101	F-6
IC102	G-1
Q100	F-5

4-16. SCHEMATIC DIAGRAM — DISPLAY SECTION — • Refer to page 15 for Common Note on Schematic Diagram.

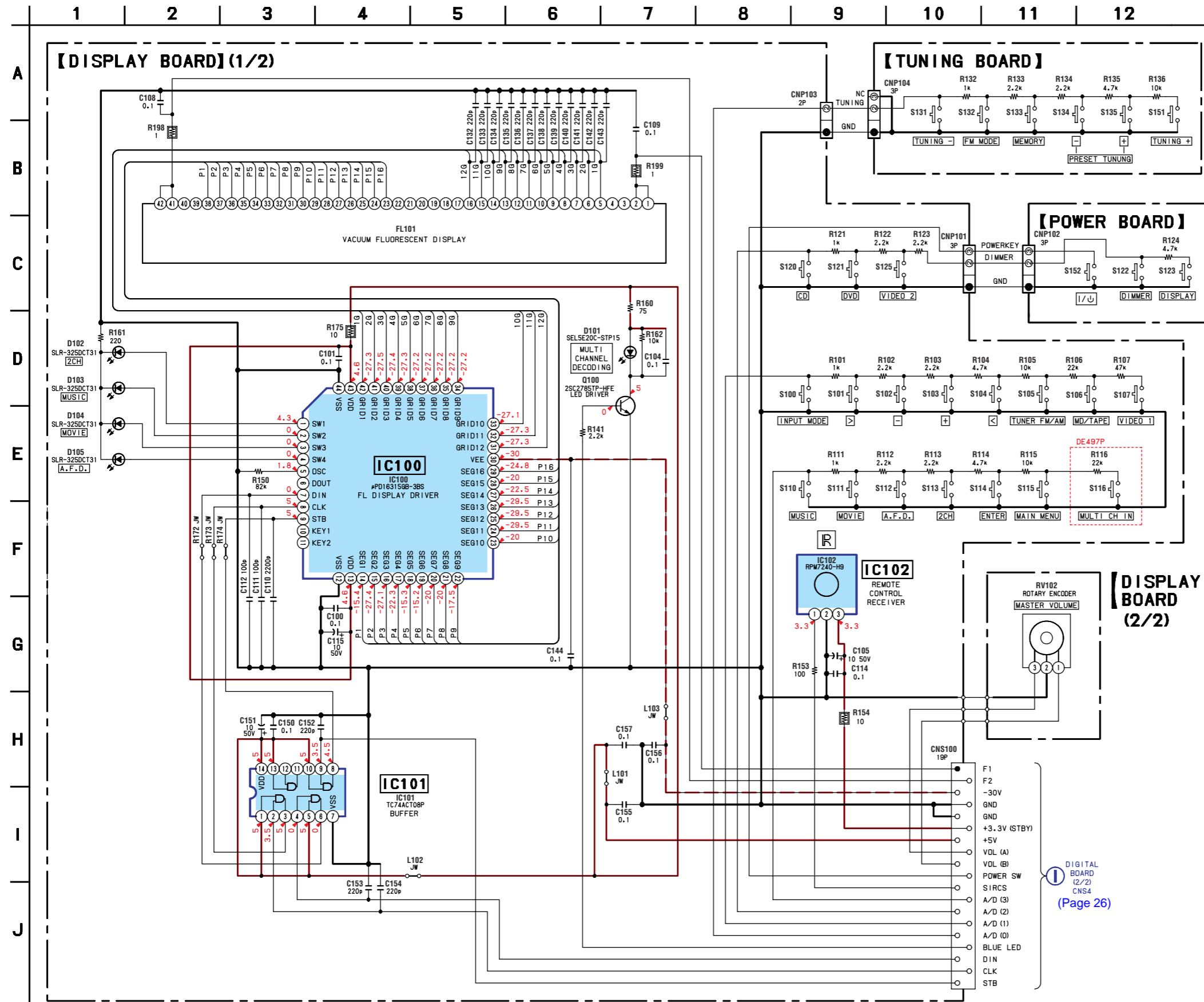

4-17. PRINTED WIRING BOARDS — POWER SECTION — • Refer to page 15 for Circuit Boards Location and Common Note on Printed Wiring Boards.

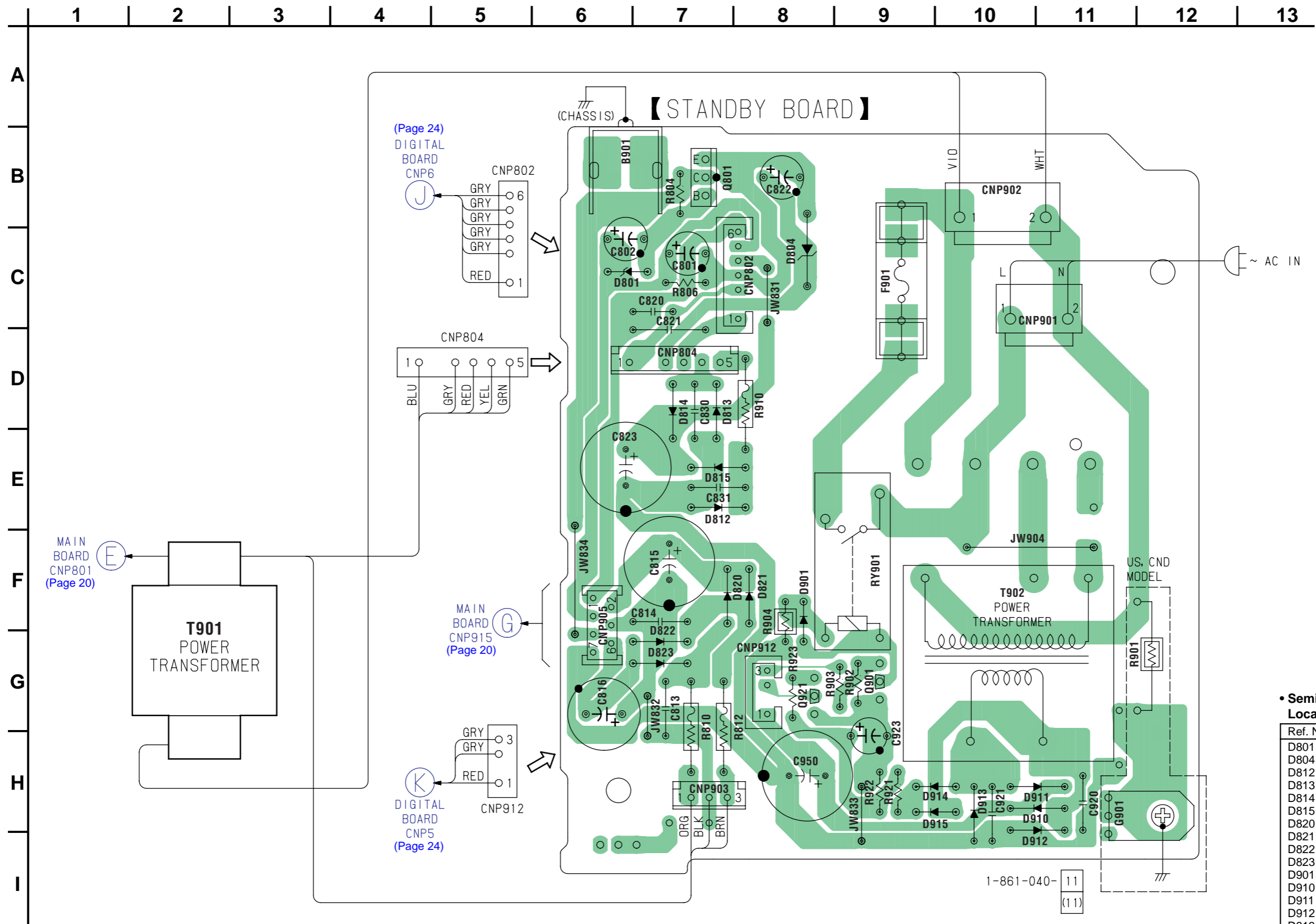

• Semiconductor Location

Ref. No.	Location
D801	C-6
D804	C-8
D812	E-7
D813	D-7
D814	D-7
D815	E-7
D820	F-7
D821	F-8
D822	G-7
D823	G-7
D901	F-8
D910	H-11
D911	H-11
D912	I-11
D913	H-10
D914	H-10
D915	H-10
Q801	B-7
Q901	G-9
Q921	G-8

4-18. SCHEMATIC DIAGRAM — POWER SECTION — • Refer to page 15 for Common Note on Schematic Diagram.

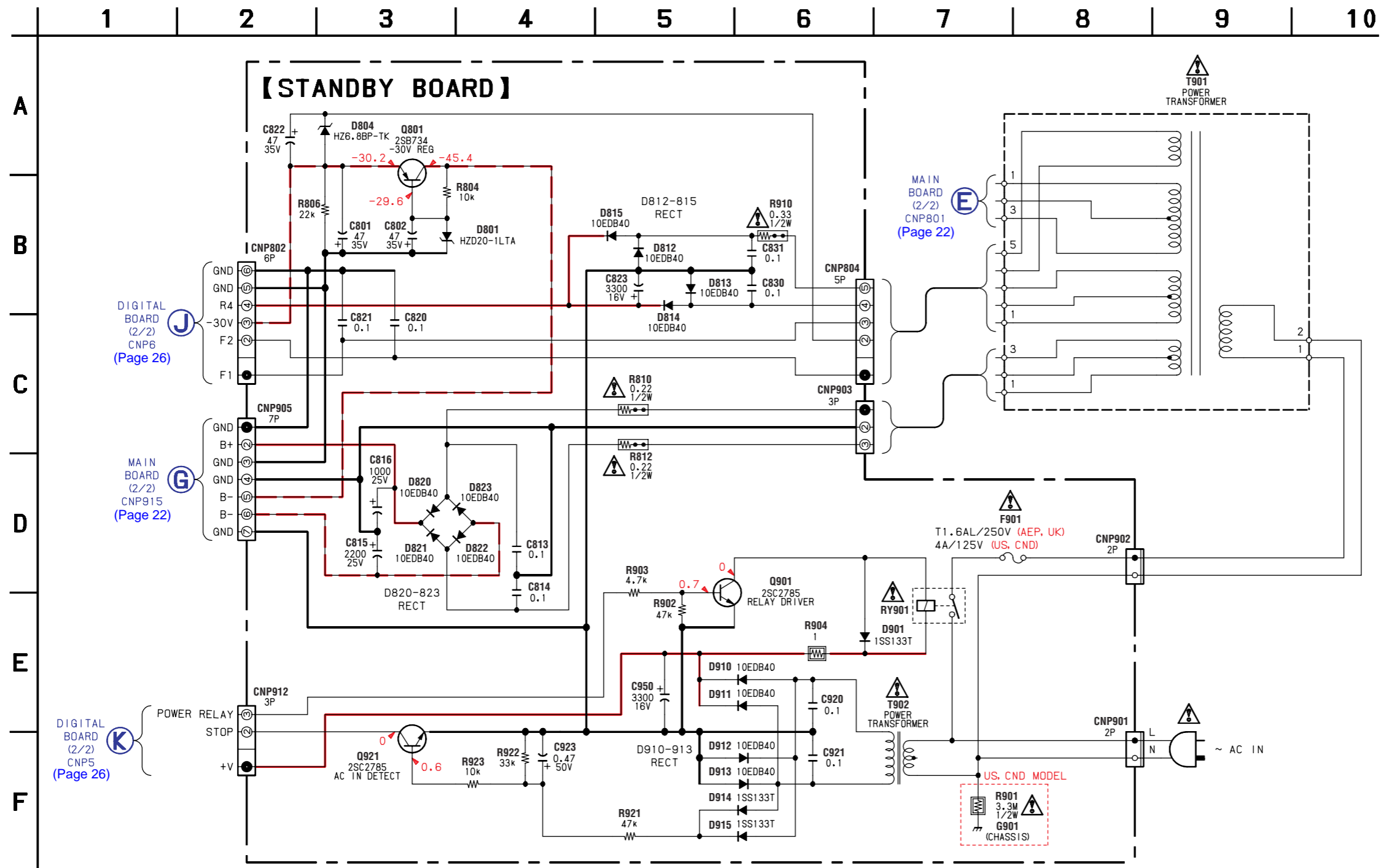

<p>The components identified by mark Δ or dotted line with mark Δ are critical for safety. Replace only with part number specified.</p>	<p>Les composants identifiés par une marque Δ sont critiques pour la sécurité. Ne les remplacer que par une pièce portant le numéro spécifié.</p>
---	---

4-19. IC BLOCK DIAGRAMS

IC201 M61527FP (MAIN BOARD (1/2))

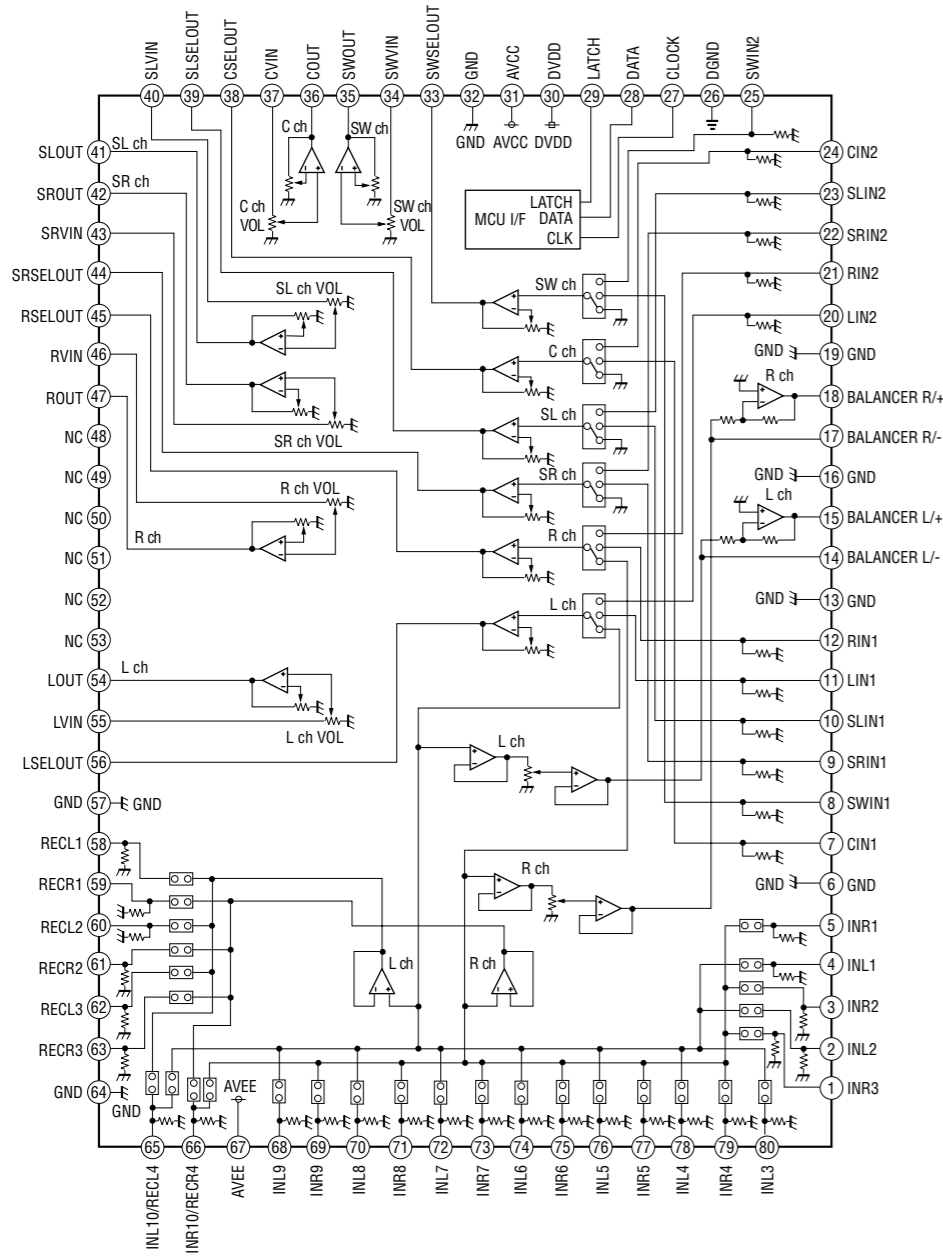

IC501 STK350-230 (MAIN BOARD (2/2))

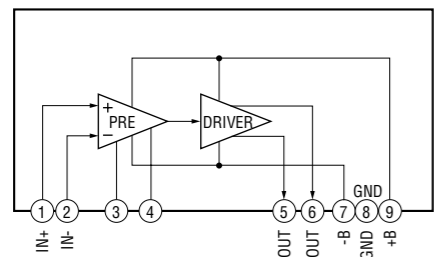

IC701 μPC2581V-S (MAIN BOARD (2/2))

IC702 μPC2581V-S (MAIN BOARD (2/2))

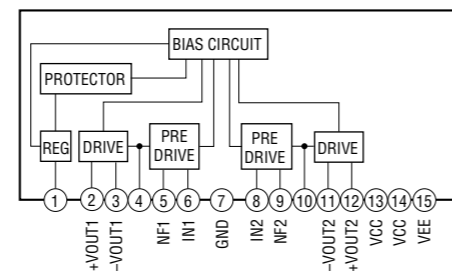

IC1101 LC89056W-E (DIGITAL BOARD (1/2))

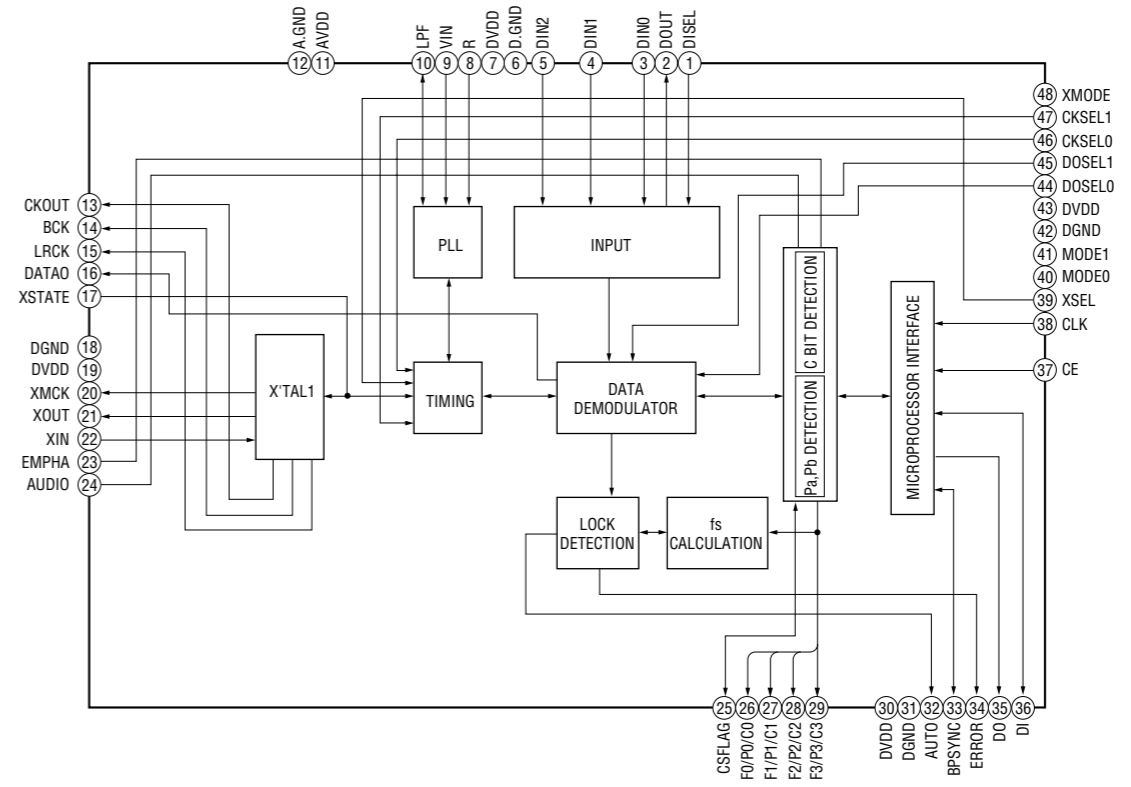

IC1501 AK4626VQ (DIGITAL BOARD (1/2))

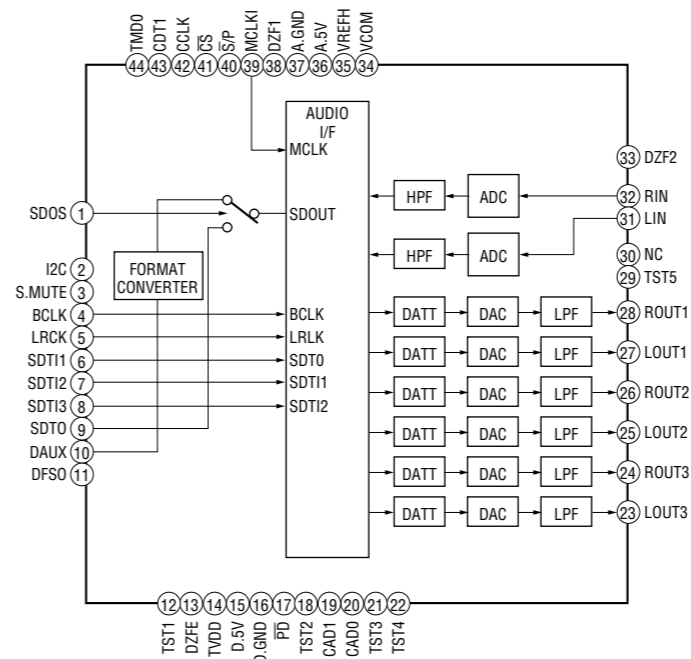

IC203 NJM2279D (VIDEO BOARD)

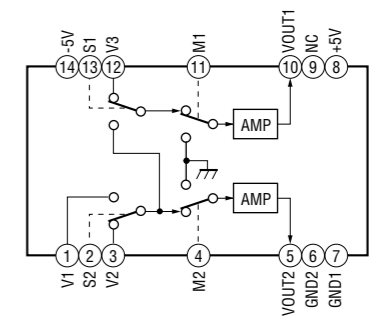

• IC Pin Descriptions

IC1201 CXD9617R (DSP) (DIGITAL Board (1/2))

Pin No.	Pin Name	I/O	Pin Description
1	VSS	—	Ground
2	XRST	I	Reset signal input from SYSTEM CONTROL IC
3	EXTIN	I	Not used (Connect to ground)
4	FS2	I	Not used (Connect to ground)
5	VDDI	I	Power supply pin (+2.6 V)
6	FS1	I	Not used (Connect to ground)
7	PLOCK	O	Not used (Open)
8	VSS	—	Ground
9	MCLK1	I	Clock signal input (13.59 MHz)
10	VDDI	I	Power supply pin (+2.6 V)
11	VSS	—	Ground
12	MCLK2	O	Clock signal output (13.59 MHz)
13	MS	I	Not used (Connect to ground)
14	SCKOUT	O	Internal system clock signal output for CODEC IC
15	LRCKI1	I	Not used (Open)
16	VDDE	I	Power supply pin (+3.3 V)
17	BCKI1	I	Not used (Open)
18	SDI1	I	Audio IF data input from CODEC IC
19	LRCKO	O	Sampling clock signal output for CODEC IC
20	BCKO	O	Bit clock signal output for CODEC IC
21	VSS	—	Ground
22	KFSIO	I/O	Audio clock signal (384fs/256fs) input/output for DIR IC
23 to 25	SDO1 to SDO3	O	Digital audio serial data output for CODEC IC
26	SDO4	O	Not used (Open)
27	SPDIF	O	Not used (Open)
28	LRCKI2	I	Sampling clock signal input from DIR IC
29	BCKI2	I	Bit clock signal input from DIR IC
30	SDI2	I	Digital audio serial data input from DIR IC
31	VSS	—	Ground
32	HACN	O	Acknowledge signal output for SYSTEM CONTROL IC
33	HDIN	I	Serial data input from SYSTEM CONTROL IC
34	HCLK	I	Clock signal input from SYSTEM CONTROL IC
35	HDOUT	O	Serial data output for SYSTEM CONTROL IC
36	HCS	I	Chip select signal input from SYSTEM CONTROL IC
37	SDCLK	O	Not used (Open)
38	CLKEN	O	Not used (Open)
39	RAS	O	Not used (Open)
40	VDDI	I	Power supply pin (+2.6 V)
41	VSS	—	Ground
42	CAS	O	Not used (Open)
43	DQM/OE0	O	Not used (Open)
44	CS0	O	External memory chip select signal output for D/A converter IC (SDRAM)
45	WE0	O	SDRAM write enable signal output for D/A converter IC (SDRAM)
46	VDDE	I	Power supply pin (+3.3 V)
47	WMD1	I	Not used (Fixed at H)
48	VSS	—	Ground
49	WMD0	I	Not used (Fixed at H)
50	PAGE2	O	Not used (Open)
51	VSS	—	Ground
52, 53	PAGE1, PAGE0	O	Not used (Open)
54	BOOT	I	Not used (Connect to ground)

STR-DE497P/K4800P/K5800P

Pin No.	Pin Name	I/O	Pin Description
55	BTACT	O	Not used (Open)
56	BST	I	Boot stop signal input from SYSTEM CONTROL IC
57	MOD1	I	Operation mode signal input (L: 386fs, H: 256fs) (Fixed at H)
58	MOD0	I	Operation mode signal input (L: single chip mode, H: use prohibited) (Fixed at L)
59	EXLOCK	I	Error detection signal input from DIR IC
60	VDDI	I	Power supply pin (+2.6 V)
61	VSS	—	Ground
62, 63	A17, A16	O	Not used (Open)
64 to 66	A15 to A13	O	External memory address signal output for D/A converter IC (SDRAM)
67	GP10	O	Connect to LRCKO
68	GP9	O	Decode signal output for SYSTEM CONTROL IC
69	GP8	I	Audio signal input from DIR IC
70	VDDI	I	Power supply pin (+2.6 V)
71	VSS	—	Ground
72 to 75	D15/GP7 to D12/GP4	I/O	External memory data input/output for D/A converter IC (general port)
76	VDDE	I	Power supply pin (+3.3 V)
77 to 80	D11/GP3 to D8/GP0	I/O	External memory data input/output for D/A converter IC (general port)
81	VSS	—	Ground
82	A9	O	External memory address signal output for D/A converter IC (SDRAM)
83 to 85	A12 to A10	O	External memory address signal output for D/A converter IC (SDRAM)
86	TDO	O	Not used (Open)
87	TMS	I	Not used (Open)
88	XTRST	I	Not used (Open)
89	TCK	I	Not used (Open)
90	TDI	I	Not used (Open)
91	VSS	—	Ground
92 to 97	A8 to A3	O	External memory address signal output for D/A converter IC (SDRAM)
98, 99	D7, D6	I/O	External memory data input/output for D/A converter IC (SDRAM)
100	VDDI	I	Power supply pin (+2.6 V)
101	VSS	—	Ground
102 to 105	D5 to D2	I/O	External memory data input/output for D/A converter IC (SDRAM)
106	VDDE	I	Power supply pin (+3.3 V)
107, 108	D1, D0	I/O	External memory data input/output for D/A converter IC (SDRAM)
109, 110	A2, A1	O	External memory address signal output for D/A converter IC (SDRAM)
111	VSS	—	Ground
112	A0	O	External memory address signal output for D/A converter IC (SDRAM)
113	PM	I	PLL initialization signal input from SYSTEM CONTROL IC
114, 115	SDI3, SDI4	I	Not used (Open)
116	SYNC	I	Sync/async select signal input (L: sync, H: async) (Fixed at H)
117 to 119	VSS	—	Ground
120	VDDI	I	Power supply pin (+2.6 V)

IC1601 MB90478PF-G-170-BND (SYSTEM CONTROL) (DIGITAL Board (2/2))

Pin No.	Pin Name	I/O	Pin Description
1	DATAO	I	Serial data line signal input from DIR IC
2	GP9	I	GP9 signal input from DSP IC
3	BST	O	Boot stop control signal output for DSP IC
4	HCS	O	Chip select signal output for DSP IC
5	HACN	I	Acknowledge signal input from DSP IC
6	XRST	O	Reset signal output for DSP IC
7	PM	O	PLL control signal output for DSP IC
8	PD	O	Power down signal output for CODEC IC
9	SMUTE	O	Soft mute signal output for CODEC IC
10	CDT1	O	Control data output for CODEC IC
11	VSS	—	Ground
12	SCL	O	Serial data clock signal output for CODEC IC
13	CS	O	Latch signal output for CODEC IC
14	DATA	O	Serial data output for VOL/TUNER IC
15	CLK	O	Clock signal output for VOL/TUNER IC
16	LATCH- VOL IC	O	Latch signal output for VOL/TUNER IC
17	SPK B RELAY	O	Not used (Fixed at L)
18	HDOUT	I	Serial data input from DSP IC
19	HDIN	O	Serial data output for DSP IC
20	HCLK	O	Serial data clock signal output for DSP IC
21	F.MUTE	O	Function mute control signal output
22	NC	O	Not used (Fixed at L)
23	VCC5	—	Power supply pin (+3.3 V)
24	ANA/DIG	O	Muting and error port signal output
25	HP DETECT	I	Headphone detection signal input
26	NC	—	Not used (Fixed at L)
27	FLASH2	—	Flash programming signal output 2
28	FLASH1	—	Flash programming signal output 1
29 to 32	NC	—	Not used (Fixed at L)
33	SCL	O	Clock signal output for EEPROM IC
34	SDA	I/O	Serial data input/output for EEPROM IC
35	AVCC	—	Power supply pin (+3.3 V)
36	AVRH	—	Power supply pin (+3.3 V)
37	AVSS	—	Ground
38 to 41	A/D0 to A/D3	I	Key signal input (A/D port)
42	VSS	—	Ground
43	RDS SIGNAL	I	RDS signal level input (STR-DE497P only)
44	MODEL	I	Model detection signal input
45	VERSION	I	Destination detection signal input
46	BLUE LED	I	LED (MULTI CHANNEL DECODING) driver signal input
47	NC	—	Not used (Fixed at L)
48	STOP	I	AC off detection signal input
49	MOD0	—	Selection of micon operation mode
50	MOD1	—	Not used (Connect to AVCC)
51	MOD2	—	Selection of micon operation mode
52	RDS CLOCK	I	RDS data clock signal input (STR-DE497P only)
53	RDS DATA	I	RDS data input (STR-DE497P only)
54	SIRCS	I	SIRCS signal input
55	FUSE DETECT	I	Fuse open detection signal input
56	POWER KEY	I	Power key detection signal input
57, 58	NC	I	Not used (Fixed at L)
59	VOL (B)	I	Volume encoder signal input

STR-DE497P/K4800P/K5800P

Pin No.	Pin Name	I/O	Pin Description
60	VOL (A)	I	Volume encoder signal input
61	DIN	O	Serial data output for FL display driver IC
62	CLK	O	Clock signal output for FL display driver IC
63	FL_STB	O	Latch signal output for FL display driver IC
64	NC	—	Not used (Fixed at L)
65	POWER RELAY	O	Power relay driver control signal output
66	PROTECTOR	O	Protector detection signal output
67	HEADPHONE RELAY	O	Headphone relay driver control signal output
68	WOOFER RELAY	O	Sub woofer relay driver control signal output
69	REAR RELAY	O	Surround speaker relay driver control signal output
70	CENTER RELAY	O	Center speaker relay driver control signal output
71	PREOUT/FRONT RELAY	O	Speaker A relay driver control signal output
72	BRIDGEABLE RELAY	O	Not used (Fixed at L)
73	TUNED	I	Tuned signal detection input
74	STEREO	I	Stereo signal detection input
75	MUTE	O	Tuner mute signal output
76	DO	I	Tuner serial data input
77	RSTX	I	Reset signal input
78	SLATCH	O	Tuner latch signal output
79	X0A	—	Not used (Open)
80	X1A	—	Not used (Connect to VSS)
81	VSS	—	Ground
82	X0	—	Clock signal input (16 MHz)
83	X1	—	Clock signal output (16 MHz)
84	VCC3	—	Power supply pin (+3.3 V)
85	REMOTE SELECT	—	Not used (Fixed at H)
86, 87	NC	—	Not used (Fixed at L)
88 to 90	SW3 to SW1	O	Video select signal output
91, 92	NC	—	Not used (Fixed at L)
93	XMODE	O	Xmode signal output for DIR IC
94	CKSEL1	O	Clock select signal output for DIR IC
95	CLK	O	Data clock signal output for DIR IC
96	CE	O	Latch signal output for DIR IC
97	DI	O	Data output for DIR IC
98	DO	I	Data input from DIR IC
99	ERROR	I	Error detection signal input from DIR IC
100	XSTATE	I	Xstate signal input from DIR IC

SECTION 5 EXPLODED VIEWS

NOTE:

- The mechanical parts with no reference number in the exploded views are not supplied.
- Items marked “*” are not stocked since they are seldom required for routine service. Some delay should be anticipated when ordering these items.
- Abbreviation
CND : Canadian model

- -XX and -X mean standardized parts, so they may have some difference from the original one.
- Color Indication of Appearance Parts
Example :
 KNOB, BALANCE (WHITE) ... (RED)
 ↑ ↑
 Parts Color Cabinet's Color
- Accessories are given in the last of this parts list.

The components identified by mark \triangle or dotted line with mark \triangle are critical for safety. Replace only with part number specified.

Les composants identifiés par une marque \triangle sont critiques pour la sécurité. Ne les remplacer que par une pièce portant le numéro spécifié.

5-1. CASE SECTION

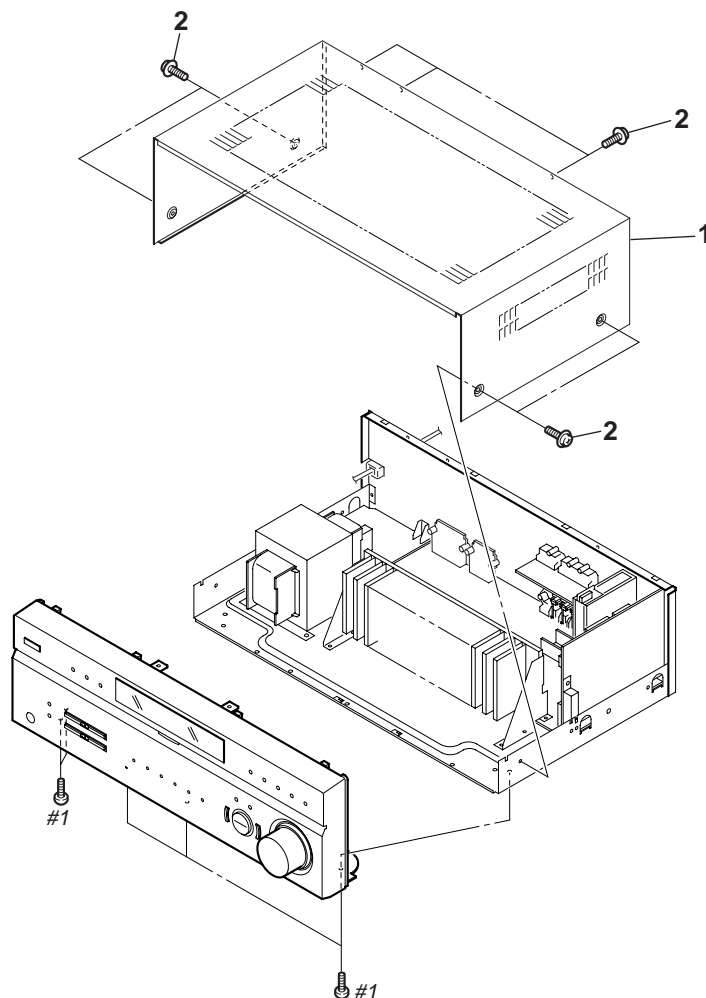

Ref. No.	Part No.	Description	Remark	Ref. No.	Part No.	Description	Remark
1	4-248-479-21	CASE		#1	7-685-646-79	SCREW +BVTP 3X8 TYPE2 IT-3	
2	3-070-883-11	SCREW, TAPPING					

5-2. FRONT PANEL SECTION

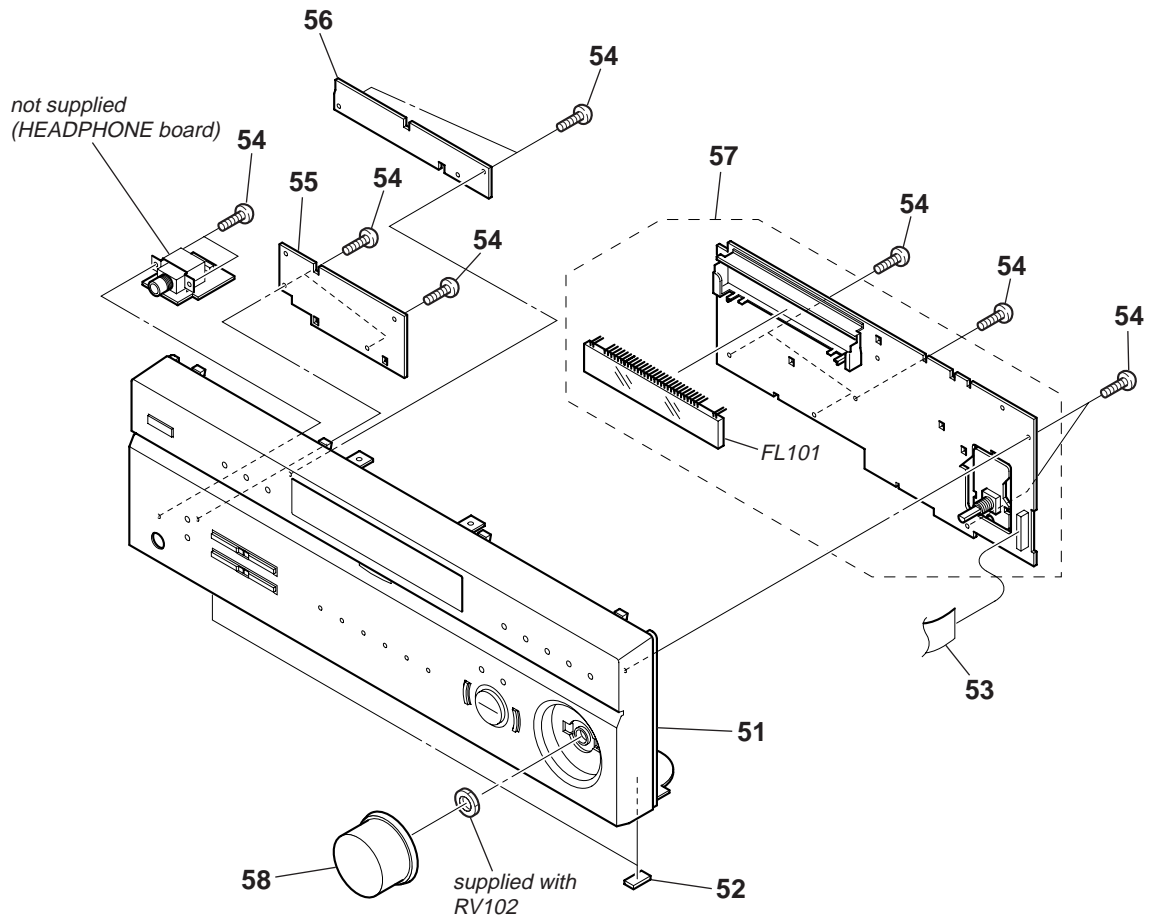

Ref. No.	Part No.	Description	Remark	Ref. No.	Part No.	Description	Remark
51	X-4956-133-1	PANEL ASSY, FRONT (DE497P)		55	1-861-044-11	TUNING BOARD	
51	X-4956-136-1	PANEL ASSY, FRONT (K4800P:US)		56	1-861-045-11	POWER BOARD	
51	X-4956-211-1	PANEL ASSY, FRONT (K4800P:CND)		57	A-4750-402-A	DISPLAY BOARD, COMPLETE (DE497P)	
51	X-4956-388-1	PANEL ASSY, FRONT (K5800P)		57	A-4752-700-A	DISPLAY BOARD, COMPLETE (K4800P/K5800P)	
52	4-977-358-01	CUSHION		58	4-232-113-12	KNOB (VOL)	
53	1-773-114-11	WIRE (FLAT TYPE) (19 CORE)		FL101	1-518-966-11	VACUUM FLUORESCENT DISPLAY	
54	4-951-620-01	SCREW (2.6X8), +BVTP					

5-3. CHASSIS SECTION-1

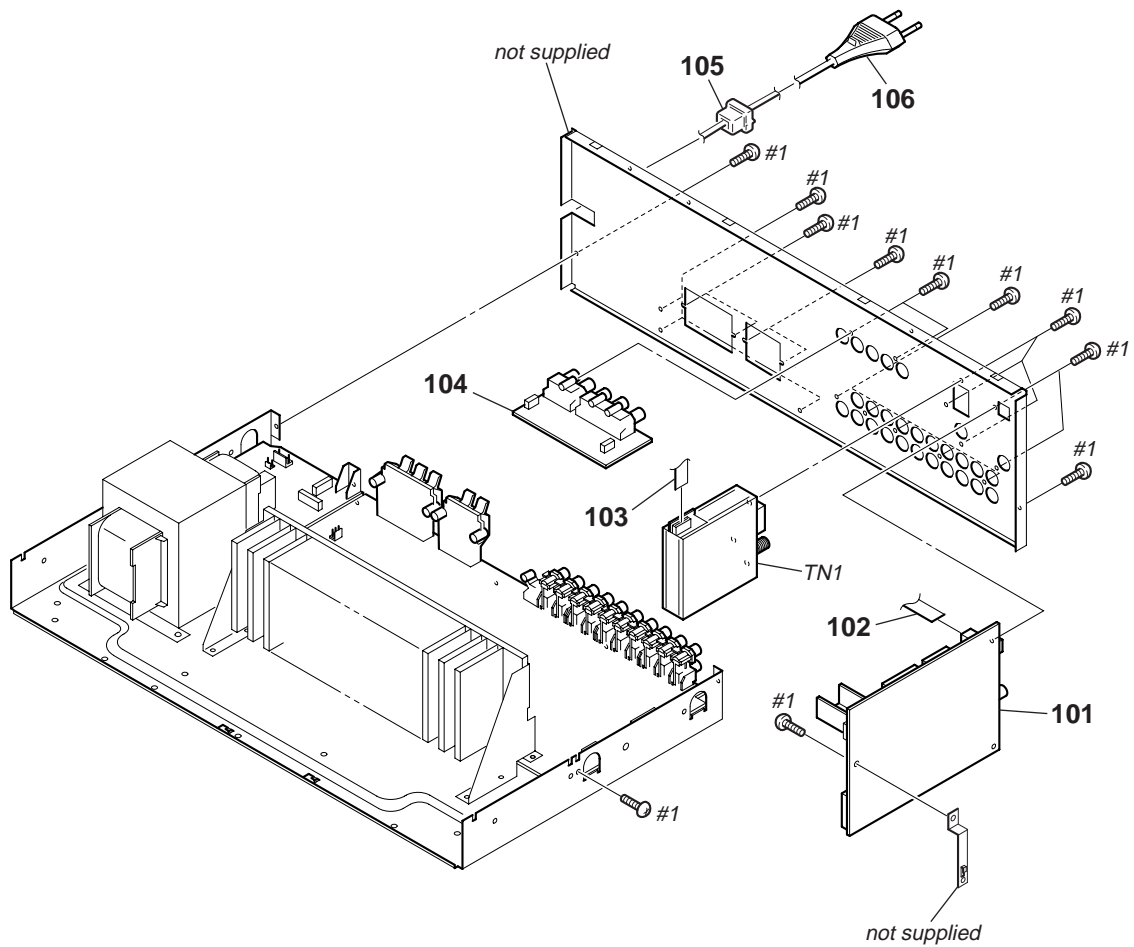

<p>The components identified by mark \triangle or dotted line with mark \triangle are critical for safety. Replace only with part number specified.</p>	<p>Les composants identifiés par une marque \triangle sont critiques pour la sécurité. Ne les remplacer que par une pièce portant le numéro spécifié.</p>
---	--

Ref. No.	Part No.	Description	Remark	Ref. No.	Part No.	Description	Remark
101	A-4750-456-A	DIGITAL BOARD, COMPLETE (DE497P)		* 105	3-703-244-00	BUSHING (2104), CORD	
101	A-4750-463-A	DIGITAL BOARD, COMPLETE (K4800P/K5800P)		\triangle 106	1-777-071-23	CORD, POWER (AEP,UK)	
102	1-575-662-31	WIRE (FLAT TYPE) (5 CORE)		\triangle 106	1-783-820-11	CORD, POWER (US,CND)	
103	1-769-937-11	WIRE (FLAT TYPE) (11 CORE)		TN1	1-693-577-13	TUNER PACK (ANTENNA) (K5800P)	
		(K4800P/K5800P)		TN1	1-693-577-21	TUNER PACK (ANTENNA) (K4800P)	
103	1-773-001-11	WIRE (FLAT TYPE) (15 CORE) (DE497P)		TN1	1-693-578-13	TUNER PACK (ANTENNA) (DE497P)	
104	A-4750-410-A	VIDEO BOARD, COMPLETE		#1	7-685-646-79	SCREW +BVTP 3X8 TYPE2 IT-3	

5-4. CHASSIS SECTION-2

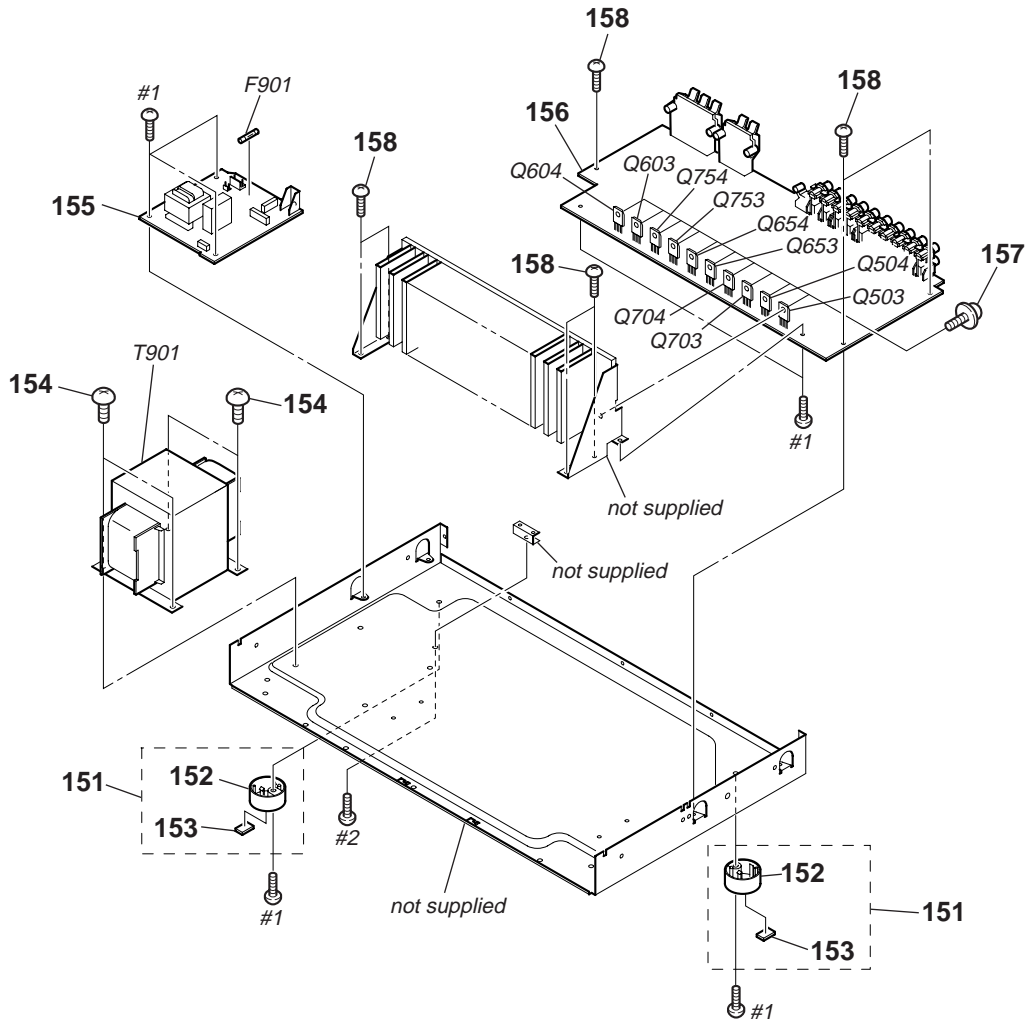

The components identified by mark \triangle or dotted line with mark \triangle are critical for safety. Replace only with part number specified.	Les composants identifiés par une marque \triangle sont critiques pour la sécurité. Ne les remplacer que par une pièce portant le numéro spécifié.
--	--

Ref. No.	Part No.	Description	Remark	Ref. No.	Part No.	Description	Remark
151	X-4953-448-1	FOOT ASSY		Q503	8-749-010-25	TRANSISTOR MN2488-OPY-M	
152	4-232-237-01	FOOT (DIA.30)		Q504	8-749-010-26	TRANSISTOR MP1620-OPY-M	
153	4-977-358-01	CUSHION		Q603	8-749-010-25	TRANSISTOR MN2488-OPY-M	
154	4-249-675-01	+BV SUMITITE S 4X6 ROUND		Q604	8-749-010-26	TRANSISTOR MP1620-OPY-M	
155	A-4750-409-A	STANDBY BOARD, COMPLETE (DE497P)		Q653	8-749-010-25	TRANSISTOR MN2488-OPY-M	
155	A-4750-608-A	STANDBY BOARD, COMPLETE (K4800P/K5800P)		Q654	8-749-010-26	TRANSISTOR MP1620-OPY-M	
156	A-4750-435-A	MAIN BOARD, COMPLETE (K4800P)		Q703	8-749-010-25	TRANSISTOR MN2488-OPY-M	
156	A-4750-441-A	MAIN BOARD, COMPLETE (DE497P)		Q704	8-749-010-26	TRANSISTOR MP1620-OPY-M	
156	A-4752-285-A	MAIN BOARD, COMPLETE (K5800P)		Q753	8-749-010-25	TRANSISTOR MN2488-OPY-M	
157	3-905-609-01	SCREW (TRANSISTOR)		Q754	8-749-010-26	TRANSISTOR MP1620-OPY-M	
158	3-970-608-01	SUMITITE (B3), +BV		\triangle T901	1-443-185-11	TRANSFORMER, POWER (K4800P:US,CND)	
\triangle F901	1-532-503-51	FUSE (T1.6AL/250V) (AEP,UK)		\triangle T901	1-443-211-11	TRANSFORMER, POWER (AEP,UK)	
\triangle F901	1-533-452-12	FUSE, GLASS TUBE (DIA.5) (4A/125V) (US,CND)		\triangle T901	1-443-248-11	TRANSFORMER, POWER (K5800P:US)	
				#1	7-685-646-79	SCREW +BVTP 3X8 TYPE2 IT-3	
				#2	7-685-645-79	SCREW +BVTP 3X6 TYPE2 N-S	

SECTION 6 ELECTRICAL PARTS LIST

DIGITAL

NOTE:

- Due to standardization, replacements in the parts list may be different from the parts specified in the diagrams or the components used on the set.
- -XX and -X mean standardized parts, so they may have some difference from the original one.
- RESISTORS
All resistors are in ohms.
METAL: Metal-film resistor.
METAL OXIDE: Metal oxide-film resistor.
F: nonflammable

- Items marked “*” are not stocked since they are seldom required for routine service. Some delay should be anticipated when ordering these items.
- SEMICONDUCTORS
In each case, u : μ , for example:
uA.. : μ A.. uPA.. : μ PA..
uPB.. : μ PB.. uPC.. : μ PC.. uPD.. : μ PD..
- CAPACITORS
uF : μ F
- COILS
uH : μ H
- Abbreviation
CND : Canadian model

The components identified by mark Δ or dotted line with mark Δ are critical for safety. Replace only with part number specified.

Les composants identifiés par une marque Δ sont critiques pour la sécurité. Ne les remplacer que par une pièce portant le numéro spécifié.

When indicating parts by reference number, please include the board.

Ref. No.	Part No.	Description	Remark	Ref. No.	Part No.	Description	Remark
	A-4750-456-A	DIGITAL BOARD, COMPLETE (DE497P)		C1216	1-162-927-11	CERAMIC CHIP 100PF	5% 50V
	A-4750-463-A	DIGITAL BOARD, COMPLETE (K4800P/K5800P)		C1218	1-162-927-11	CERAMIC CHIP 100PF	5% 50V
		*****		C1219	1-164-156-11	CERAMIC CHIP 0.1uF	25V
				C1220	1-162-927-11	CERAMIC CHIP 100PF	5% 50V
	7-685-646-79	SCREW +BVTP 3X8 TYPE2 IT-3		C1229	1-164-156-11	CERAMIC CHIP 0.1uF	25V
		< CAPACITOR >		C1230	1-164-156-11	CERAMIC CHIP 0.1uF	25V
C1101	1-164-156-11	CERAMIC CHIP 0.1uF	25V	C1231	1-164-156-11	CERAMIC CHIP 0.1uF	25V
C1102	1-126-204-11	ELECT CHIP 47uF	20% 16V	C1300	1-164-156-11	CERAMIC CHIP 0.1uF	25V
C1103	1-164-156-11	CERAMIC CHIP 0.1uF	25V	C1301	1-164-156-11	CERAMIC CHIP 0.1uF	25V
C1104	1-162-974-11	CERAMIC CHIP 0.01uF	50V	C1302	1-164-156-11	CERAMIC CHIP 0.1uF	25V
C1105	1-126-204-11	ELECT CHIP 47uF	20% 16V	C1303	1-164-156-11	CERAMIC CHIP 0.1uF	25V (DE497P)
C1106	1-164-156-11	CERAMIC CHIP 0.1uF	25V	C1304	1-164-156-11	CERAMIC CHIP 0.1uF	25V
C1107	1-162-974-11	CERAMIC CHIP 0.01uF	50V	C1315	1-162-927-11	CERAMIC CHIP 100PF	5% 50V
C1108	1-164-156-11	CERAMIC CHIP 0.1uF	25V	C1365	1-162-927-11	CERAMIC CHIP 100PF	5% 50V
C1109	1-162-918-11	CERAMIC CHIP 18PF	5% 50V	C1502	1-124-778-00	ELECT CHIP 22uF	20% 6.3V
C1110	1-162-918-11	CERAMIC CHIP 18PF	5% 50V	C1505	1-164-156-11	CERAMIC CHIP 0.1uF	25V
C1111	1-164-156-11	CERAMIC CHIP 0.1uF	25V	C1506	1-128-396-11	ELECT CHIP 470uF	20% 10V
C1112	1-162-974-11	CERAMIC CHIP 0.01uF	50V	C1507	1-124-779-00	ELECT CHIP 10uF	20% 16V
C1113	1-164-156-11	CERAMIC CHIP 0.1uF	25V	C1508	1-164-156-11	CERAMIC CHIP 0.1uF	25V
C1114	1-162-905-11	CERAMIC CHIP 1PF	0.25PF 50V	C1509	1-164-156-11	CERAMIC CHIP 0.1uF	25V
C1115	1-162-923-11	CERAMIC CHIP 47PF	5% 50V	C1511	1-164-156-11	CERAMIC CHIP 0.1uF	25V
C1116	1-110-530-11	ELECT CHIP 1000uF	20% 6.3V	C1512	1-162-995-11	CERAMIC CHIP 0.022uF	50V
C1117	1-164-156-11	CERAMIC CHIP 0.1uF	25V	C1513	1-164-156-11	CERAMIC CHIP 0.1uF	25V
C1118	1-115-416-11	CERAMIC CHIP 0.001uF	5% 25V	C1514	1-162-974-11	CERAMIC CHIP 0.01uF	50V
C1119	1-124-778-00	ELECT CHIP 22uF	20% 6.3V	C1515	1-128-396-11	ELECT CHIP 470uF	20% 10V
C1120	1-164-156-11	CERAMIC CHIP 0.1uF	25V	C1516	1-162-967-11	CERAMIC CHIP 0.0033uF	10% 50V
C1124	1-164-156-11	CERAMIC CHIP 0.1uF	25V	C1517	1-162-967-11	CERAMIC CHIP 0.0033uF	10% 50V
C1129	1-115-416-11	CERAMIC CHIP 0.001uF	5% 25V	C1518	1-162-967-11	CERAMIC CHIP 0.0033uF	10% 50V
C1130	1-164-156-11	CERAMIC CHIP 0.1uF	25V	C1519	1-162-967-11	CERAMIC CHIP 0.0033uF	10% 50V
C1131	1-162-927-11	CERAMIC CHIP 100PF	5% 50V	C1520	1-162-967-11	CERAMIC CHIP 0.0033uF	10% 50V
C1201	1-164-156-11	CERAMIC CHIP 0.1uF	25V	C1521	1-162-967-11	CERAMIC CHIP 0.0033uF	10% 50V
C1202	1-164-156-11	CERAMIC CHIP 0.1uF	25V	C1523	1-115-416-11	CERAMIC CHIP 0.001uF	5% 25V
C1203	1-164-156-11	CERAMIC CHIP 0.1uF	25V	C1552	1-124-778-00	ELECT CHIP 22uF	20% 6.3V
C1204	1-164-156-11	CERAMIC CHIP 0.1uF	25V	C1601	1-164-156-11	CERAMIC CHIP 0.1uF	25V
C1205	1-164-156-11	CERAMIC CHIP 0.1uF	25V	C1602	1-164-156-11	CERAMIC CHIP 0.1uF	25V
C1206	1-164-156-11	CERAMIC CHIP 0.1uF	25V	C1603	1-164-156-11	CERAMIC CHIP 0.1uF	25V
C1207	1-164-156-11	CERAMIC CHIP 0.1uF	25V	C1604	1-164-156-11	CERAMIC CHIP 0.1uF	25V
C1208	1-164-156-11	CERAMIC CHIP 0.1uF	25V	C1605	1-164-156-11	CERAMIC CHIP 0.1uF	25V
C1209	1-164-156-11	CERAMIC CHIP 0.1uF	25V	C1606	1-126-204-11	ELECT CHIP 47uF	20% 16V
C1210	1-164-156-11	CERAMIC CHIP 0.1uF	25V	C1608	1-164-156-11	CERAMIC CHIP 0.1uF	25V
C1211	1-128-396-11	ELECT CHIP 470uF	20% 10V	C1610	1-162-974-11	CERAMIC CHIP 0.01uF	50V
C1212	1-128-396-11	ELECT CHIP 470uF	20% 10V	C1611	1-162-974-11	CERAMIC CHIP 0.01uF	50V
C1213	1-164-156-11	CERAMIC CHIP 0.1uF	25V	C1612	1-164-156-11	CERAMIC CHIP 0.1uF	25V
C1214	1-164-156-11	CERAMIC CHIP 0.1uF	25V	C1613	1-164-156-11	CERAMIC CHIP 0.1uF	25V

Ref. No.	Part No.	Description	Remark	Ref. No.	Part No.	Description	Remark
R1115	1-216-833-11	METAL CHIP	10K 5% 1/10W	R1313	1-216-809-11	METAL CHIP	100 5% 1/10W (DE497P)
R1116	1-218-285-11	METAL CHIP	75 5% 1/10W	R1314	1-216-809-11	METAL CHIP	100 5% 1/10W (DE497P)
R1117	1-216-821-11	METAL CHIP	1K 5% 1/10W	R1315	1-216-864-11	SHORT CHIP	0
R1118	1-216-854-11	METAL CHIP	560K 5% 1/10W	R1365	1-216-864-11	SHORT CHIP	0
R1119	1-216-837-11	METAL CHIP	22K 5% 1/10W	R1508	1-216-841-11	METAL CHIP	47K 5% 1/10W
R1120	1-216-809-11	METAL CHIP	100 5% 1/10W	R1509	1-216-821-11	METAL CHIP	1K 5% 1/10W
R1122	1-216-833-11	METAL CHIP	10K 5% 1/10W	R1516	1-216-813-11	METAL CHIP	220 5% 1/10W
R1124	1-216-809-11	METAL CHIP	100 5% 1/10W	R1517	1-216-813-11	METAL CHIP	220 5% 1/10W
R1202	1-216-809-11	METAL CHIP	100 5% 1/10W	R1518	1-216-813-11	METAL CHIP	220 5% 1/10W
R1203	1-216-833-11	METAL CHIP	10K 5% 1/10W	R1519	1-216-813-11	METAL CHIP	220 5% 1/10W
R1204	1-216-821-11	METAL CHIP	1K 5% 1/10W	R1520	1-216-813-11	METAL CHIP	220 5% 1/10W
R1205	1-216-809-11	METAL CHIP	100 5% 1/10W	R1521	1-216-813-11	METAL CHIP	220 5% 1/10W
R1206	1-216-809-11	METAL CHIP	100 5% 1/10W	R1600	1-216-829-11	METAL CHIP	4.7K 5% 1/10W
R1207	1-216-809-11	METAL CHIP	100 5% 1/10W	R1601	1-216-821-11	METAL CHIP	1K 5% 1/10W
R1208	1-216-809-11	METAL CHIP	100 5% 1/10W	R1602	1-216-829-11	METAL CHIP	4.7K 5% 1/10W
R1209	1-216-809-11	METAL CHIP	100 5% 1/10W	R1603	1-216-821-11	METAL CHIP	1K 5% 1/10W
R1210	1-216-833-11	METAL CHIP	10K 5% 1/10W	R1604	1-216-809-11	METAL CHIP	100 5% 1/10W
R1212	1-216-813-11	METAL CHIP	220 5% 1/10W	R1605	1-216-809-11	METAL CHIP	100 5% 1/10W
R1213	1-216-813-11	METAL CHIP	220 5% 1/10W	R1606	1-216-821-11	METAL CHIP	1K 5% 1/10W
R1214	1-216-813-11	METAL CHIP	220 5% 1/10W	R1607	1-216-821-11	METAL CHIP	1K 5% 1/10W
R1215	1-216-813-11	METAL CHIP	220 5% 1/10W	R1608	1-216-821-11	METAL CHIP	1K 5% 1/10W
R1216	1-216-813-11	METAL CHIP	220 5% 1/10W	R1609	1-216-821-11	METAL CHIP	1K 5% 1/10W
R1217	1-216-813-11	METAL CHIP	220 5% 1/10W	R1610	1-216-821-11	METAL CHIP	1K 5% 1/10W
R1218	1-216-813-11	METAL CHIP	220 5% 1/10W	R1611	1-216-821-11	METAL CHIP	1K 5% 1/10W
R1219	1-216-813-11	METAL CHIP	220 5% 1/10W	R1612	1-216-821-11	METAL CHIP	1K 5% 1/10W
R1220	1-216-813-11	METAL CHIP	220 5% 1/10W	R1613	1-216-821-11	METAL CHIP	1K 5% 1/10W
R1221	1-216-813-11	METAL CHIP	220 5% 1/10W	R1614	1-216-821-11	METAL CHIP	1K 5% 1/10W
R1222	1-216-813-11	METAL CHIP	220 5% 1/10W	R1615	1-216-821-11	METAL CHIP	1K 5% 1/10W
R1224	1-216-813-11	METAL CHIP	220 5% 1/10W	R1617	1-216-809-11	METAL CHIP	100 5% 1/10W
R1225	1-216-813-11	METAL CHIP	220 5% 1/10W	R1618	1-216-809-11	METAL CHIP	100 5% 1/10W
R1226	1-216-813-11	METAL CHIP	220 5% 1/10W	R1619	1-216-809-11	METAL CHIP	100 5% 1/10W
R1227	1-216-813-11	METAL CHIP	220 5% 1/10W	R1621	1-216-821-11	METAL CHIP	1K 5% 1/10W
R1228	1-216-813-11	METAL CHIP	220 5% 1/10W	R1622	1-216-833-11	METAL CHIP	10K 5% 1/10W
R1229	1-216-813-11	METAL CHIP	220 5% 1/10W	R1624	1-216-833-11	METAL CHIP	10K 5% 1/10W
R1230	1-216-813-11	METAL CHIP	220 5% 1/10W	R1625	1-216-833-11	METAL CHIP	10K 5% 1/10W
R1231	1-216-813-11	METAL CHIP	220 5% 1/10W	R1626	1-216-833-11	METAL CHIP	10K 5% 1/10W
R1232	1-216-813-11	METAL CHIP	220 5% 1/10W	R1627	1-216-833-11	METAL CHIP	10K 5% 1/10W
R1233	1-216-813-11	METAL CHIP	220 5% 1/10W	R1628	1-216-833-11	METAL CHIP	10K 5% 1/10W
R1234	1-216-813-11	METAL CHIP	220 5% 1/10W	R1629	1-216-833-11	METAL CHIP	10K 5% 1/10W
R1235	1-216-813-11	METAL CHIP	220 5% 1/10W	R1630	1-216-833-11	METAL CHIP	10K 5% 1/10W
R1236	1-216-813-11	METAL CHIP	220 5% 1/10W	R1631	1-216-829-11	METAL CHIP	4.7K 5% 1/10W
R1237	1-216-813-11	METAL CHIP	220 5% 1/10W	R1632	1-216-825-11	METAL CHIP	2.2K 5% 1/10W (DE497P)
R1238	1-216-813-11	METAL CHIP	220 5% 1/10W	R1632	1-216-864-11	SHORT CHIP	0 (K4800P/K5800P)
R1239	1-216-813-11	METAL CHIP	220 5% 1/10W	R1633	1-216-841-11	METAL CHIP	47K 5% 1/10W (DE497P)
R1240	1-216-813-11	METAL CHIP	220 5% 1/10W	R1635	1-216-833-11	METAL CHIP	10K 5% 1/10W
R1241	1-216-813-11	METAL CHIP	220 5% 1/10W	R1636	1-216-833-11	METAL CHIP	10K 5% 1/10W
R1242	1-216-813-11	METAL CHIP	220 5% 1/10W	R1638	1-216-829-11	METAL CHIP	4.7K 5% 1/10W
R1243	1-216-813-11	METAL CHIP	220 5% 1/10W	R1639	1-216-809-11	METAL CHIP	100 5% 1/10W
R1244	1-216-813-11	METAL CHIP	220 5% 1/10W	R1640	1-216-809-11	METAL CHIP	100 5% 1/10W
R1300	1-216-809-11	METAL CHIP	100 5% 1/10W	R1641	1-216-809-11	METAL CHIP	100 5% 1/10W
R1301	1-216-809-11	METAL CHIP	100 5% 1/10W	R1642	1-216-833-11	METAL CHIP	10K 5% 1/10W
R1302	1-216-809-11	METAL CHIP	100 5% 1/10W	R1643	1-216-821-11	METAL CHIP	1K 5% 1/10W
R1303	1-216-809-11	METAL CHIP	100 5% 1/10W	R1644	1-216-821-11	METAL CHIP	1K 5% 1/10W
R1304	1-216-809-11	METAL CHIP	100 5% 1/10W	R1645	1-216-821-11	METAL CHIP	1K 5% 1/10W
R1305	1-216-841-11	METAL CHIP	47K 5% 1/10W	R1646	1-216-821-11	METAL CHIP	1K 5% 1/10W
R1306	1-216-841-11	METAL CHIP	47K 5% 1/10W				
R1312	1-216-809-11	METAL CHIP	100 5% 1/10W (DE497P)				

STR-DE497P/K4800P/K5800P

DIGITAL **DISPLAY**

Ref. No.	Part No.	Description	Remark
R1647	1-216-821-11	METAL CHIP 1K 5%	1/10W
R1648	1-216-821-11	METAL CHIP 1K 5%	1/10W
R1649	1-216-821-11	METAL CHIP 1K 5%	1/10W
R1650	1-216-833-11	METAL CHIP 10K 5%	1/10W
R1651	1-216-833-11	METAL CHIP 10K 5%	1/10W
R1652	1-216-833-11	METAL CHIP 10K 5%	1/10W
R1653	1-216-833-11	METAL CHIP 10K 5%	1/10W
R1654	1-216-833-11	METAL CHIP 10K 5%	1/10W
R1655	1-216-833-11	METAL CHIP 10K 5%	1/10W
R1656	1-216-841-11	METAL CHIP 47K 5%	1/10W
R1657	1-216-833-11	METAL CHIP 10K 5%	1/10W
R1658	1-216-809-11	METAL CHIP 100 5%	1/10W
R1660	1-216-833-11	METAL CHIP 10K 5%	1/10W
R1662	1-216-827-11	METAL CHIP 3.3K 5%	1/10W
R1663	1-216-827-11	METAL CHIP 3.3K 5%	1/10W
R1666	1-216-821-11	METAL CHIP 1K 5%	1/10W
R1667	1-216-821-11	METAL CHIP 1K 5%	1/10W
R1668	1-216-833-11	METAL CHIP 10K 5%	1/10W
R1669	1-216-833-11	METAL CHIP 10K 5%	1/10W
R1670	1-216-833-11	METAL CHIP 10K 5%	1/10W
R1671	1-216-829-11	METAL CHIP 4.7K 5%	1/10W
R1672	1-216-841-11	METAL CHIP 47K 5%	1/10W
R1673	1-216-833-11	METAL CHIP 10K 5%	1/10W
R1675	1-216-833-11	METAL CHIP 10K 5%	1/10W
R1676	1-216-833-11	METAL CHIP 10K 5%	1/10W
R1677	1-216-821-11	METAL CHIP 1K 5%	1/10W
R1678	1-216-821-11	METAL CHIP 1K 5%	1/10W
R1679	1-216-821-11	METAL CHIP 1K 5%	1/10W
R1680	1-216-833-11	METAL CHIP 10K 5%	1/10W
R1681	1-216-833-11	METAL CHIP 10K 5%	1/10W
R1682	1-216-845-11	METAL CHIP 100K 5%	1/10W
R1683	1-216-833-11	METAL CHIP 10K 5%	1/10W
R1684	1-216-833-11	METAL CHIP 10K 5%	1/10W
R1685	1-216-833-11	METAL CHIP 10K 5%	1/10W
R1686	1-216-833-11	METAL CHIP 10K 5%	1/10W
R1687	1-216-833-11	METAL CHIP 10K 5%	1/10W
R1688	1-216-864-11	SHORT CHIP 0	
R1689	1-216-833-11	METAL CHIP 10K 5%	1/10W
R1690	1-216-833-11	METAL CHIP 10K 5%	1/10W
R1694	1-216-821-11	METAL CHIP 1K 5%	1/10W
R1696	1-216-833-11	METAL CHIP 10K 5%	1/10W
R1697	1-216-833-11	METAL CHIP 10K 5%	1/10W
R1698	1-216-829-11	METAL CHIP 4.7K 5%	1/10W
R1699	1-216-829-11	METAL CHIP 4.7K 5%	1/10W
< VIBRATOR >			
X1101	1-795-126-21	VIBRATOR, CRYSTAL (12.288MHz)	
X1201	1-795-363-21	VIBRATOR, CERAMIC (13.59MHz)	
X1601	1-767-922-11	VIBRATOR, CERAMIC (16MHz)	

A-4750-402-A	DISPLAY BOARD, COMPLETE (DE497P)		
A-4752-700-A	DISPLAY BOARD, COMPLETE (K4800P/K5800P)		

< CAPACITOR >			
C100	1-164-159-11	CERAMIC 0.1uF	50V
C101	1-164-159-11	CERAMIC 0.1uF	50V

Ref. No.	Part No.	Description	Remark
C104	1-164-159-11	CERAMIC 0.1uF	50V
C105	1-126-795-11	ELECT 10uF	20% 50V
C108	1-164-159-11	CERAMIC 0.1uF	50V
C109	1-164-159-11	CERAMIC 0.1uF	50V
C110	1-128-825-11	CERAMIC 0.0022uF	5% 50V
C111	1-128-809-11	CERAMIC 100PF	5% 50V
C112	1-128-809-11	CERAMIC 100PF	5% 50V
C114	1-164-159-11	CERAMIC 0.1uF	50V
C115	1-126-795-11	ELECT 10uF	20% 50V
C132	1-128-813-11	CERAMIC 220PF	5% 50V
C133	1-128-813-11	CERAMIC 220PF	5% 50V
C134	1-128-813-11	CERAMIC 220PF	5% 50V
C135	1-128-813-11	CERAMIC 220PF	5% 50V
C136	1-128-813-11	CERAMIC 220PF	5% 50V
C137	1-128-813-11	CERAMIC 220PF	5% 50V
C138	1-128-813-11	CERAMIC 220PF	5% 50V
C139	1-128-813-11	CERAMIC 220PF	5% 50V
C140	1-128-813-11	CERAMIC 220PF	5% 50V
C141	1-128-813-11	CERAMIC 220PF	5% 50V
C142	1-128-813-11	CERAMIC 220PF	5% 50V
C143	1-128-813-11	CERAMIC 220PF	5% 50V
C144	1-164-159-11	CERAMIC 0.1uF	50V
C150	1-164-159-11	CERAMIC 0.1uF	50V
C151	1-126-795-11	ELECT 10uF	20% 50V
C152	1-128-813-11	CERAMIC 220PF	5% 50V
C153	1-128-813-11	CERAMIC 220PF	5% 50V
C154	1-128-813-11	CERAMIC 220PF	5% 50V
C155	1-164-159-11	CERAMIC 0.1uF	50V
C156	1-164-159-11	CERAMIC 0.1uF	50V
C157	1-164-159-11	CERAMIC 0.1uF	50V
< CONNECTOR >			
* CNP101	1-564-518-11	PLUG, CONNECTOR 3P	
* CNP103	1-564-517-11	PLUG, CONNECTOR 2P	
CNS100	1-569-323-11	SOCKET, CONNECTOR 19P	
< DIODE >			
D101	6-500-647-01	LED SEL5E20C-STP15 (MULTI CHANNEL DECODING)	
D102	8-719-061-96	LED SLR-325DCT31 (2CH)	
D103	8-719-061-96	LED SLR-325DCT31 (MUSIC)	
D104	8-719-061-96	LED SLR-325DCT31 (MOVIE)	
D105	8-719-061-96	LED SLR-325DCT31 (A.F.D.)	
< VACUUM FLUORESCENT DISPLAY >			
FL101	1-518-966-11	VACUUM FLUORESCENT DISPLAY	
< IC >			
IC100	8-759-643-83	IC uPD16315GB-3BS	
IC101	8-759-243-51	IC TC74ACT08P	
IC102	6-600-309-01	IC RPM7240-H9 (IR)	
< TRANSISTOR >			
Q100	8-729-119-78	TRANSISTOR 2SC2785-HFE	
< RESISTOR >			
R101	1-247-831-11	CARBON 1K 5%	1/4W
R102	1-249-421-11	CARBON 2.2K 5%	1/4W

DISPLAY

HEADPHONE

MAIN

Ref. No.	Part No.	Description	Remark	Ref. No.	Part No.	Description	Remark
R103	1-249-421-11	CARBON	2.2K 5% 1/4W			HEADPHONE BOARD	
R104	1-247-847-11	CARBON	4.7K 5% 1/4W			*****	
R105	1-249-429-11	CARBON	10K 5% 1/4W			< CONNECTOR >	
R106	1-247-863-11	CARBON	22K 5% 1/4W				
R107	1-247-871-11	CARBON	47K 5% 1/4W				
R111	1-247-831-11	CARBON	1K 5% 1/4W				
R112	1-249-421-11	CARBON	2.2K 5% 1/4W			< JACK >	
R113	1-249-421-11	CARBON	2.2K 5% 1/4W				
R114	1-247-847-11	CARBON	4.7K 5% 1/4W				
R115	1-249-429-11	CARBON	10K 5% 1/4W				
R116	1-247-863-11	CARBON	22K 5% 1/4W (DE497P)			A-4750-435-A MAIN BOARD, COMPLETE (K4800P)	
R121	1-247-831-11	CARBON	1K 5% 1/4W			A-4750-441-A MAIN BOARD, COMPLETE (DE497P)	
R122	1-249-421-11	CARBON	2.2K 5% 1/4W			A-4752-285-A MAIN BOARD, COMPLETE (K5800P)	
R123	1-249-421-11	CARBON	2.2K 5% 1/4W			*****	
R141	1-249-421-11	CARBON	2.2K 5% 1/4W			7-685-646-79 SCREW +BVTP 3X8 TYPE2 IT-3	
R150	1-249-440-11	CARBON	82K 5% 1/4W			< CAPACITOR >	
R153	1-247-807-31	CARBON	100 5% 1/4W				
R154	1-249-393-11	CARBON	10 5% 1/4W F			C371 1-161-494-00 CERAMIC 0.022uF 25V	
R160	1-247-804-11	CARBON	75 5% 1/4W			C372 1-161-494-00 CERAMIC 0.022uF 25V	
R161	1-249-409-11	CARBON	220 5% 1/4W			C373 1-161-494-00 CERAMIC 0.022uF 25V	
R162	1-249-429-11	CARBON	10K 5% 1/4W			C374 1-164-159-11 CERAMIC 0.1uF 50V	
R175	1-249-393-11	CARBON	10 5% 1/4W F			C375 1-161-494-00 CERAMIC 0.022uF 25V	
R198	1-249-381-11	CARBON	1 5% 1/4W F			C376 1-161-494-00 CERAMIC 0.022uF 25V	
R199	1-249-381-11	CARBON	1 5% 1/4W F			C400 1-164-159-11 CERAMIC 0.1uF 50V	
		< ROTARY ENCODER >				C408 1-126-963-11 ELECT 4.7uF 20% 50V	
RV102	1-418-725-41	ENCODER, ROTARY (12 TYPE) (MASTER VOLUME)				C409 1-126-963-11 ELECT 4.7uF 20% 50V	
		< SWITCH >				C413 1-126-961-11 ELECT 2.2uF 20% 50V	
S100	1-771-410-21	SWITCH, TACTILE (INPUT MODE)				C414 1-126-961-11 ELECT 2.2uF 20% 50V	
S101	1-771-410-21	SWITCH, TACTILE (>)				C415 1-126-961-11 ELECT 2.2uF 20% 50V	
S102	1-771-410-21	SWITCH, TACTILE (-)				C416 1-126-961-11 ELECT 2.2uF 20% 50V	
S103	1-771-410-21	SWITCH, TACTILE (+)				C417 1-126-961-11 ELECT 2.2uF 20% 50V	
S104	1-771-410-21	SWITCH, TACTILE (<)				C418 1-126-961-11 ELECT 2.2uF 20% 50V	
S105	1-771-410-21	SWITCH, TACTILE (TUNER FM/AM)				C419 1-126-961-11 ELECT 2.2uF 20% 50V	
S106	1-771-410-21	SWITCH, TACTILE (MD/TAPE)				C433 1-126-961-11 ELECT 2.2uF 20% 50V	
S107	1-771-410-21	SWITCH, TACTILE (VIDEO 1)				C458 1-126-963-11 ELECT 4.7uF 20% 50V	
S110	1-771-410-21	SWITCH, TACTILE (MUSIC)				C459 1-126-963-11 ELECT 4.7uF 20% 50V	
S111	1-771-410-21	SWITCH, TACTILE (MOVIE)				C464 1-164-159-11 CERAMIC 0.1uF 50V	
S112	1-771-410-21	SWITCH, TACTILE (A.F.D.)				C465 1-126-934-11 ELECT 220uF 20% 16V	
S113	1-771-410-21	SWITCH, TACTILE (2CH)				C467 1-164-159-11 CERAMIC 0.1uF 50V	
S114	1-771-410-21	SWITCH, TACTILE (ENTER)				C471 1-126-963-11 ELECT 4.7uF 20% 50V	
S115	1-771-410-21	SWITCH, TACTILE (MAIN MENU)				C472 1-126-963-11 ELECT 4.7uF 20% 50V	
S116	1-771-410-21	SWITCH, TACTILE (MULTI CH IN) (DE497P)				C475 1-104-658-11 ELECT 100uF 20% 10V	
S120	1-771-410-21	SWITCH, TACTILE (CD)				C481 1-126-963-11 ELECT 4.7uF 20% 50V	
S121	1-771-410-21	SWITCH, TACTILE (DVD)				C482 1-126-963-11 ELECT 4.7uF 20% 50V	
S125	1-771-410-21	SWITCH, TACTILE (VIDEO 2)				C483 1-126-963-11 ELECT 4.7uF 20% 50V	
*****						C484 1-126-963-11 ELECT 4.7uF 20% 50V	
						C485 1-126-964-11 ELECT 10uF 20% 50V	
						C486 1-126-963-11 ELECT 4.7uF 20% 50V	
						C487 1-126-964-11 ELECT 10uF 20% 50V	
						C488 1-164-159-11 CERAMIC 0.1uF 50V	
						C489 1-128-809-11 CERAMIC 100PF 5% 50V	
						C490 1-128-809-11 CERAMIC 100PF 5% 50V	
						C491 1-126-963-11 ELECT 4.7uF 20% 50V	
						C492 1-126-963-11 ELECT 4.7uF 20% 50V	
						C493 1-126-963-11 ELECT 4.7uF 20% 50V	
						C494 1-126-963-11 ELECT 4.7uF 20% 50V	
						C495 1-126-963-11 ELECT 4.7uF 20% 50V	

STR-DE497P/K4800P/K5800P

MAIN

Ref. No.	Part No.	Description	Remark			Ref. No.	Part No.	Description	Remark		
C496	1-126-963-11	ELECT	4.7uF	20%	50V	C721	1-126-934-11	ELECT	220uF	20%	16V
C497	1-128-809-11	CERAMIC	100PF	5%	50V	C722	1-126-964-11	ELECT	10uF	20%	50V
C498	1-128-803-11	CERAMIC	33PF	5%	50V	C732	1-128-582-11	ELECT	10uF	20%	100V
C500	1-128-825-11	CERAMIC	0.0022uF	5%	50V	C733	1-128-582-11	ELECT	10uF	20%	100V
C501	1-126-963-11	ELECT	4.7uF	20%	50V	C740	1-126-964-11	ELECT	10uF	20%	50V
C503	1-104-658-11	ELECT	100uF	20%	10V	C742	1-127-876-11	CERAMIC	0.01uF	10%	50V
C504	1-107-583-11	CERAMIC	3PF	0.25PF	500V	C744	1-128-579-11	ELECT	2.2uF	20%	100V
C505	1-106-359-00	MYLAR	0.0047uF	5%	50V	C750	1-126-964-11	ELECT	10uF	20%	50V
C506	1-102-233-00	CERAMIC	33PF	10%	500V	C751	1-126-963-11	ELECT	4.7uF	20%	50V
C507	1-128-809-11	CERAMIC	100PF	5%	50V	C752	1-127-876-11	CERAMIC	0.01uF	10%	50V
C508	1-128-809-11	CERAMIC	100PF	5%	50V	C753	1-104-658-11	ELECT	100uF	20%	10V
C510	1-126-947-11	ELECT	47uF	20%	35V	C754	1-107-583-11	CERAMIC	3PF	0.25PF	500V
C511	1-136-157-00	FILM	0.022uF	5%	50V	C755	1-102-233-00	CERAMIC	33PF	10%	500V
C516	1-162-815-11	CERAMIC	47PF	5%	500V	C756	1-128-813-11	CERAMIC	220PF	5%	50V
C517	1-162-815-11	CERAMIC	47PF	5%	500V	C757	1-128-809-11	CERAMIC	100PF	5%	50V
C519	1-128-813-11	CERAMIC	220PF	5%	50V	C760	1-126-947-11	ELECT	47uF	20%	35V
C540	1-126-964-11	ELECT	10uF	20%	50V	C761	1-136-157-00	FILM	0.022uF	5%	50V
C541	1-127-876-11	CERAMIC	0.01uF	10%	50V	C766	1-162-815-11	CERAMIC	47PF	5%	500V
C601	1-126-963-11	ELECT	4.7uF	20%	50V	C767	1-162-815-11	CERAMIC	47PF	5%	500V
C603	1-104-658-11	ELECT	100uF	20%	10V	C770	1-128-813-11	CERAMIC	220PF	5%	50V
C604	1-107-583-11	CERAMIC	3PF	0.25PF	500V	C800	1-128-825-11	CERAMIC	0.0022uF	5%	50V (DE497P)
C605	1-102-233-00	CERAMIC	33PF	10%	500V	C803	1-165-498-11	ELECT	4700uF	20%	63V (DE497P/K4800P)
C606	1-128-813-11	CERAMIC	220PF	5%	50V	C803	1-165-960-11	ELECT	6800uF	20%	71V (K5800P)
C607	1-128-809-11	CERAMIC	100PF	5%	50V	C804	1-165-498-11	ELECT	4700uF	20%	63V (DE497P/K4800P)
C610	1-126-947-11	ELECT	47uF	20%	35V	C804	1-165-960-11	ELECT	6800uF	20%	71V (K5800P)
C611	1-136-157-00	FILM	0.022uF	5%	50V	C805	1-135-851-21	MYLAR	0.22uF		100V (K5800P)
C619	1-128-813-11	CERAMIC	220PF	5%	50V	C805	1-136-497-81	FILM	0.1uF	5%	50V (DE497P/K4800P)
C620	1-162-815-11	CERAMIC	47PF	5%	500V	C806	1-135-851-21	MYLAR	0.22uF		100V (K5800P)
C621	1-162-815-11	CERAMIC	47PF	5%	500V	C806	1-136-497-81	FILM	0.1uF	5%	50V (DE497P/K4800P)
C640	1-126-964-11	ELECT	10uF	20%	50V	C807	1-104-658-11	ELECT	100uF	20%	10V
C642	1-127-876-11	CERAMIC	0.01uF	10%	50V	C808	1-126-925-11	ELECT	470uF	20%	10V
C643	1-128-579-11	ELECT	2.2uF	20%	100V	C810	1-164-159-11	CERAMIC	0.1uF		50V
C651	1-126-963-11	ELECT	4.7uF	20%	50V	C811	1-164-159-11	CERAMIC	0.1uF		50V
C653	1-104-658-11	ELECT	100uF	20%	10V	CC02	1-128-809-11	CERAMIC	100PF	5%	50V (DE497P)
C654	1-107-583-11	CERAMIC	3PF	0.25PF	500V	CC04	1-128-809-11	CERAMIC	100PF	5%	50V (DE497P)
C655	1-102-233-00	CERAMIC	33PF	10%	500V	CC05	1-128-809-11	CERAMIC	100PF	5%	50V (DE497P)
C656	1-128-813-11	CERAMIC	220PF	5%	50V	CC06	1-128-809-11	CERAMIC	100PF	5%	50V (DE497P)
C657	1-128-809-11	CERAMIC	100PF	5%	50V	CC07	1-128-809-11	CERAMIC	100PF	5%	50V (DE497P)
C660	1-126-947-11	ELECT	47uF	20%	35V	CC08	1-128-809-11	CERAMIC	100PF	5%	50V (DE497P)
C661	1-136-157-00	FILM	0.022uF	5%	50V	CC09	1-128-809-11	CERAMIC	100PF	5%	50V (DE497P)
C666	1-162-815-11	CERAMIC	47PF	5%	500V	CC12	1-127-876-11	CERAMIC	0.01uF	10%	50V (DE497P)
C669	1-162-815-11	CERAMIC	47PF	5%	500V	CC14	1-127-876-11	CERAMIC	0.01uF	10%	50V (DE497P)
C670	1-128-813-11	CERAMIC	220PF	5%	50V						
C680	1-126-964-11	ELECT	10uF	20%	50V						
C681	1-127-876-11	CERAMIC	0.01uF	10%	50V						
C691	1-164-159-11	CERAMIC	0.1uF		50V						
C700	1-128-825-11	CERAMIC	0.0022uF	5%	50V						
C701	1-126-963-11	ELECT	4.7uF	20%	50V						
C703	1-104-658-11	ELECT	100uF	20%	10V						
C704	1-107-583-11	CERAMIC	3PF	0.25PF	500V						
C705	1-102-233-00	CERAMIC	33PF	10%	500V						
C706	1-128-813-11	CERAMIC	220PF	5%	50V						
C707	1-128-809-11	CERAMIC	100PF	5%	50V						
C710	1-126-947-11	ELECT	47uF	20%	35V						
C711	1-136-157-00	FILM	0.022uF	5%	50V						
C716	1-162-815-11	CERAMIC	47PF	5%	500V						
C717	1-162-815-11	CERAMIC	47PF	5%	500V						
C720	1-128-813-11	CERAMIC	220PF	5%	50V						

Ref. No.	Part No.	Description	Remark	Ref. No.	Part No.	Description	Remark
CC16	1-127-876-11	CERAMIC	0.01uF 10% 50V (DE497P)	D750	8-719-991-33	DIODE 1SS133T-77	
CC18	1-127-876-11	CERAMIC	0.01uF 10% 50V (DE497P)	D765	8-719-991-33	DIODE 1SS133T-77	
CC20	1-127-876-11	CERAMIC	0.01uF 10% 50V (DE497P)	D791	8-719-991-33	DIODE 1SS133T-77	
CC31	1-128-813-11	CERAMIC	220PF 5% 50V (DE497P)	D802	8-719-072-05	DIODE RBV-602LF-A	
CC32	1-128-813-11	CERAMIC	220PF 5% 50V (DE497P)	D896	8-719-043-76	DIODE AK04V0	
CC41	1-128-813-11	CERAMIC	220PF 5% 50V (DE497P)			< IC >	
CC42	1-128-813-11	CERAMIC	220PF 5% 50V (DE497P)	IC201	6-703-501-01	IC M61527FP	
CC52	1-128-809-11	CERAMIC	100PF 5% 50V (DE497P)	IC401	8-759-167-88	IC NJM4565D	
CC54	1-128-809-11	CERAMIC	100PF 5% 50V (DE497P)	IC501	8-749-011-16	IC STK350-230	
CC55	1-128-809-11	CERAMIC	100PF 5% 50V (DE497P)	IC601	8-759-167-88	IC NJM4565D	
CC56	1-128-809-11	CERAMIC	100PF 5% 50V (DE497P)	IC701	6-700-943-01	IC uPC2581V-S	
CC57	1-128-809-11	CERAMIC	100PF 5% 50V (DE497P)	IC702	6-700-943-01	IC uPC2581V-S	
CC58	1-128-809-11	CERAMIC	100PF 5% 50V (DE497P)	IC801	8-759-071-48	IC TA7807S	
CC59	1-128-809-11	CERAMIC	100PF 5% 50V (DE497P)	IC802	8-759-071-47	IC TA79007S	
CC61	1-128-813-11	CERAMIC	220PF 5% 50V (DE497P)			< JACK >	
CC62	1-128-813-11	CERAMIC	220PF 5% 50V (DE497P)	J401	1-793-775-12	JACK, PIN 6P (MULTI CH IN CENTER, SUB WOOFER, SURROUND, FRONT) (DE497P)	
		< CONNECTOR >		J402	1-691-887-11	JACK, PIN 6P (MD/TAPE IN/OUT, CD IN)	
CNP501	1-573-845-11	CONNECTOR, BOARD TO BOARD 13P		J403	1-794-981-11	JACK, PIN 4P (VIDEO 2 AUDIO IN, DVD AUDIO IN)	
* CNP502	1-774-876-21	CONNECTOR, BOARD TO BOARD 8P		J404	1-770-614-11	JACK, PIN 4P (VIDEO 1 AUDIO IN/OUT)	
* CNP801	1-564-104-00	PIN, CONNECTOR (3.96mm PITCH) 3P		J405	1-774-785-11	JACK, PIN 1P (SUB WOOFER AUDIO OUT)	
CNP911	1-784-924-11	PIN, CONNECTOR 8P				< COIL >	
CNP915	1-793-674-21	CONNECTOR, BOARD TO BOARD 7P		L521	1-420-872-52	COIL, AIR-CORE	
		< DIODE >		L601	1-420-872-52	COIL, AIR-CORE	
D505	8-719-991-33	DIODE 1SS133T-77		L651	1-420-872-52	COIL, AIR-CORE	
D510	8-719-991-33	DIODE 1SS133T-77		L701	1-420-872-52	COIL, AIR-CORE	
D540	8-719-991-33	DIODE 1SS133T-77		L751	1-420-872-52	COIL, AIR-CORE	
D560	8-719-991-33	DIODE 1SS133T-77				< TRANSISTOR >	
D605	8-719-991-33	DIODE 1SS133T-77		Q361	8-729-922-37	TRANSISTOR 2SD2144S-UVW	
D610	8-719-991-33	DIODE 1SS133T-77		Q362	8-729-922-37	TRANSISTOR 2SD2144S-UVW	
D640	8-719-991-33	DIODE 1SS133T-77		Q363	8-729-922-37	TRANSISTOR 2SD2144S-UVW	
D665	8-719-991-33	DIODE 1SS133T-77		Q364	8-729-922-37	TRANSISTOR 2SD2144S-UVW	
D680	8-719-991-33	DIODE 1SS133T-77		Q365	8-729-922-37	TRANSISTOR 2SD2144S-UVW	
D690	8-719-934-21	DIODE HZS30-1L		Q366	8-729-922-37	TRANSISTOR 2SD2144S-UVW	
D691	8-719-991-33	DIODE 1SS133T-77		Q379	8-729-900-63	TRANSISTOR DTA124ES	
D705	8-719-991-33	DIODE 1SS133T-77		Q471	8-729-922-37	TRANSISTOR 2SD2144S-UVW	
D710	8-719-991-33	DIODE 1SS133T-77		Q501	8-729-119-76	TRANSISTOR 2SA1175-HFE	
D721	8-719-991-33	DIODE 1SS133T-77		Q502	8-729-141-30	TRANSISTOR 2SC3623A-LK	
D722	8-719-991-33	DIODE 1SS133T-77		Q505	8-729-042-09	TRANSISTOR 2SA1038S-RSE-TP	
D731	8-719-991-33	DIODE 1SS133T-77		Q506	8-729-042-09	TRANSISTOR 2SA1038S-RSE-TP	
D732	8-719-991-33	DIODE 1SS133T-77		Q540	8-729-281-53	TRANSISTOR 2SC1815-GR	
D733	8-719-991-33	DIODE 1SS133T-77		Q550	8-729-119-79	TRANSISTOR 2SC2785-FEK	
D734	8-719-991-33	DIODE 1SS133T-77		Q560	8-729-119-79	TRANSISTOR 2SC2785-FEK	
D740	8-719-991-33	DIODE 1SS133T-77		Q601	8-729-119-76	TRANSISTOR 2SA1175-HFE	
				Q602	8-729-141-30	TRANSISTOR 2SC3623A-LK	
				Q605	8-729-042-09	TRANSISTOR 2SA1038S-RSE-TP	
				Q606	8-729-042-09	TRANSISTOR 2SA1038S-RSE-TP	
				Q610	8-729-119-79	TRANSISTOR 2SC2785-FEK	
				Q640	8-729-281-53	TRANSISTOR 2SC1815-GR	
				Q651	8-729-119-76	TRANSISTOR 2SA1175-HFE	
				Q652	8-729-141-30	TRANSISTOR 2SC3623A-LK	
				Q655	8-729-042-09	TRANSISTOR 2SA1038S-RSE-TP	
				Q656	8-729-042-09	TRANSISTOR 2SA1038S-RSE-TP	

STR-DE497P/K4800P/K5800P

Ver 1.1

MAIN

Ref. No.	Part No.	Description	Remark	Ref. No.	Part No.	Description	Remark
Q680	8-729-281-53	TRANSISTOR 2SC1815-GR		R455	1-247-831-11	CARBON 1K 5%	1/4W
Q691	8-729-281-53	TRANSISTOR 2SC1815-GR		R456	1-247-831-11	CARBON 1K 5%	1/4W
Q692	8-729-900-63	TRANSISTOR DTA124ES		R457	1-247-831-11	CARBON 1K 5%	1/4W
Q701	8-729-119-76	TRANSISTOR 2SA1175-HFE		R458	1-247-831-11	CARBON 1K 5%	1/4W
Q702	8-729-141-30	TRANSISTOR 2SC3623A-LK		R459	1-247-831-11	CARBON 1K 5%	1/4W
Q705	8-729-042-09	TRANSISTOR 2SA1038S-RSE-TP		R461	1-247-831-11	CARBON 1K 5%	1/4W
Q706	8-729-042-09	TRANSISTOR 2SA1038S-RSE-TP					(DE497P)
Q710	8-729-119-79	TRANSISTOR 2SC2785-FEK		R462	1-247-831-11	CARBON 1K 5%	1/4W
Q722	8-729-140-84	TRANSISTOR 2SC1841-PAFAEA					(DE497P)
Q723	8-729-119-79	TRANSISTOR 2SC2785-FEK		R469	1-247-831-11	CARBON 1K 5%	1/4W
Q725	8-729-042-09	TRANSISTOR 2SA1038S-RSE-TP		R470	1-247-871-11	CARBON 47K 5%	1/4W
Q740	8-729-281-53	TRANSISTOR 2SC1815-GR		R471	1-249-415-11	CARBON 680 5%	1/4W
Q750	8-729-281-53	TRANSISTOR 2SC1815-GR		R472	1-247-831-11	CARBON 1K 5%	1/4W
Q751	8-729-119-76	TRANSISTOR 2SA1175-HFE		R473	1-247-847-11	CARBON 4.7K 5%	1/4W
Q752	8-729-141-30	TRANSISTOR 2SC3623A-LK		R474	1-249-429-11	CARBON 10K 5%	1/4W
Q755	8-729-042-09	TRANSISTOR 2SA1038S-RSE-TP		R475	1-249-421-11	CARBON 2.2K 5%	1/4W
Q756	8-729-042-09	TRANSISTOR 2SA1038S-RSE-TP		R476	1-247-807-31	CARBON 100 5%	1/4W
Q790	8-729-119-79	TRANSISTOR 2SC2785-FEK		R477	1-247-807-31	CARBON 100 5%	1/4W
		< RESISTOR >		R478	1-247-807-31	CARBON 100 5%	1/4W
R360	1-247-879-11	CARBON 100K 5%	1/4W	R479	1-249-421-11	CARBON 2.2K 5%	1/4W
R361	1-247-847-11	CARBON 4.7K 5%	1/4W	R499	1-247-871-11	CARBON 47K 5%	1/4W
R362	1-247-847-11	CARBON 4.7K 5%	1/4W	R501	1-247-831-11	CARBON 1K 5%	1/4W
R363	1-247-879-11	CARBON 100K 5%	1/4W	R502	1-249-439-11	CARBON 68K 5%	1/4W
R366	1-249-429-11	CARBON 10K 5%	1/4W	R503	1-249-421-11	CARBON 2.2K 5%	1/4W
R367	1-247-879-11	CARBON 100K 5%	1/4W	R504	1-249-411-11	CARBON 330 5%	1/4W
R368	1-247-871-11	CARBON 47K 5%	1/4W	R505	1-249-439-11	CARBON 68K 5%	1/4W
R369	1-247-847-11	CARBON 4.7K 5%	1/4W	R510	1-249-421-11	CARBON 2.2K 5%	1/4W
R370	1-247-847-11	CARBON 4.7K 5%	1/4W	R511	1-249-440-11	CARBON 82K 5%	1/4W
R371	1-247-879-11	CARBON 100K 5%	1/4W	R513	1-249-414-11	CARBON 560 5%	1/4W
R372	1-247-879-11	CARBON 100K 5%	1/4W	R514	1-249-405-11	CARBON 100 5%	1/4W F
R373	1-247-831-11	CARBON 1K 5%	1/4W	R515	1-249-405-11	CARBON 100 5%	1/4W F
R374	1-247-831-11	CARBON 1K 5%	1/4W	R516	1-234-182-11	ENCAPSULATED COMPONENT 0.22X2 5W	
R375	1-247-831-11	CARBON 1K 5%	1/4W	R517	1-249-393-11	CARBON 10 5%	1/4W F
R376	1-247-831-11	CARBON 1K 5%	1/4W	R520	1-247-847-11	CARBON 4.7K 5%	1/4W
R377	1-247-831-11	CARBON 1K 5%	1/4W	R521	1-247-850-11	CARBON 6.2K 5%	1/4W
R378	1-247-831-11	CARBON 1K 5%	1/4W	R522	1-249-419-11	CARBON 1.5K 5%	1/4W
R379	1-247-847-11	CARBON 4.7K 5%	1/4W	R524	1-249-431-11	CARBON 15K 5%	1/4W
R380	1-247-879-11	CARBON 100K 5%	1/4W	R525	1-249-439-11	CARBON 68K 5%	1/4W
R381	1-249-429-11	CARBON 10K 5%	1/4W	R528	1-249-389-11	CARBON 4.7 5%	1/4W F
R402	1-247-831-11	CARBON 1K 5%	1/4W	R531	1-247-847-11	CARBON 4.7K 5%	1/4W
R404	1-247-831-11	CARBON 1K 5%	1/4W	R532	1-247-847-11	CARBON 4.7K 5%	1/4W
R405	1-247-831-11	CARBON 1K 5%	1/4W	R533	1-247-871-11	CARBON 47K 5%	1/4W
R406	1-247-831-11	CARBON 1K 5%	1/4W	R534	1-249-404-00	CARBON 82 5%	1/4W F
R407	1-247-831-11	CARBON 1K 5%	1/4W	R540	1-247-863-11	CARBON 22K 5%	1/4W
R408	1-247-831-11	CARBON 1K 5%	1/4W	R546	1-247-843-11	CARBON 3.3K 5%	1/4W
R409	1-247-831-11	CARBON 1K 5%	1/4W	R555	1-247-863-11	CARBON 22K 5%	1/4W
R410	1-247-871-11	CARBON 47K 5%	1/4W	R556	1-247-863-11	CARBON 22K 5%	1/4W
R411	1-247-831-11	CARBON 1K 5%	1/4W	R557	1-249-431-11	CARBON 15K 5%	1/4W
R412	1-247-831-11	CARBON 1K 5%	1/4W	R563	1-249-429-11	CARBON 10K 5%	1/4W
			(DE497P)	R573	1-247-871-11	CARBON 47K 5%	1/4W
			(DE497P)	R601	1-247-831-11	CARBON 1K 5%	1/4W
R430	1-247-871-11	CARBON 47K 5%	1/4W	R602	1-249-439-11	CARBON 68K 5%	1/4W
R431	1-247-831-11	CARBON 1K 5%	1/4W	R603	1-249-421-11	CARBON 2.2K 5%	1/4W
			(DE497P)	R604	1-249-439-11	CARBON 68K 5%	1/4W
R432	1-247-831-11	CARBON 1K 5%	1/4W	R610	1-249-421-11	CARBON 2.2K 5%	1/4W
			(DE497P)	R611	1-249-440-11	CARBON 82K 5%	1/4W
R452	1-247-831-11	CARBON 1K 5%	1/4W	R613	1-249-414-11	CARBON 560 5%	1/4W
R454	1-247-831-11	CARBON 1K 5%	1/4W	R614	1-249-405-11	CARBON 100 5%	1/4W F

Ref. No.	Part No.	Description	Remark	Ref. No.	Part No.	Description	Remark
R615	1-249-405-11	CARBON	100 5% 1/4W F	R711	1-249-440-11	CARBON	82K 5% 1/4W
R616	1-234-182-11	ENCAPSULATED COMPONENT	0.22X2 5W	R713	1-249-414-11	CARBON	560 5% 1/4W
R617	1-249-393-11	CARBON	10 5% 1/4W F	R714	1-249-405-11	CARBON	100 5% 1/4W F
R618	1-249-389-11	CARBON	4.7 5% 1/4W F	R715	1-249-405-11	CARBON	100 5% 1/4W F
R620	1-247-847-11	CARBON	4.7K 5% 1/4W	R716	1-234-182-11	ENCAPSULATED COMPONENT	0.22X2 5W
R621	1-247-850-11	CARBON	6.2K 5% 1/4W	R717	1-249-393-11	CARBON	10 5% 1/4W F
R622	1-249-419-11	CARBON	1.5K 5% 1/4W	R718	1-249-389-11	CARBON	4.7 5% 1/4W F
R623	1-247-871-11	CARBON	47K 5% 1/4W	R719	1-247-847-11	CARBON	4.7K 5% 1/4W
R624	1-249-431-11	CARBON	15K 5% 1/4W	R721	1-247-850-11	CARBON	6.2K 5% 1/4W
R625	1-249-439-11	CARBON	68K 5% 1/4W	R722	1-249-419-11	CARBON	1.5K 5% 1/4W
R631	1-247-847-11	CARBON	4.7K 5% 1/4W	R723	1-247-871-11	CARBON	47K 5% 1/4W
R634	1-249-404-00	CARBON	82 5% 1/4W F	R724	1-249-431-11	CARBON	15K 5% 1/4W
R638	1-249-439-11	CARBON	68K 5% 1/4W	R725	1-249-439-11	CARBON	68K 5% 1/4W
R640	1-247-863-11	CARBON	22K 5% 1/4W	R731	1-247-847-11	CARBON	4.7K 5% 1/4W
R643	1-247-863-11	CARBON	22K 5% 1/4W	R732	1-249-381-11	CARBON	1 5% 1/4W F
R648	1-247-843-11	CARBON	3.3K 5% 1/4W	R733	1-249-381-11	CARBON	1 5% 1/4W F
R651	1-247-831-11	CARBON	1K 5% 1/4W	R734	1-249-404-00	CARBON	82 5% 1/4W F
R652	1-249-439-11	CARBON	68K 5% 1/4W	R735	1-249-427-11	CARBON	6.8K 5% 1/4W
R653	1-249-421-11	CARBON	2.2K 5% 1/4W	R736	1-247-831-11	CARBON	1K 5% 1/4W
R654	1-249-439-11	CARBON	68K 5% 1/4W	R737	1-249-436-11	CARBON	39K 5% 1/4W
R655	1-247-863-11	CARBON	22K 5% 1/4W	R740	1-247-863-11	CARBON	22K 5% 1/4W
R656	1-247-863-11	CARBON	22K 5% 1/4W	R744	1-247-863-11	CARBON	22K 5% 1/4W
R657	1-249-431-11	CARBON	15K 5% 1/4W	R745	1-247-863-11	CARBON	22K 5% 1/4W
R660	1-249-421-11	CARBON	2.2K 5% 1/4W	R746	1-247-863-11	CARBON	22K 5% 1/4W
R661	1-249-440-11	CARBON	82K 5% 1/4W	R747	1-249-431-11	CARBON	15K 5% 1/4W
R663	1-249-414-11	CARBON	560 5% 1/4W	R748	1-247-843-11	CARBON	3.3K 5% 1/4W
R664	1-249-405-11	CARBON	100 5% 1/4W F	R750	1-247-863-11	CARBON	22K 5% 1/4W
R665	1-249-405-11	CARBON	100 5% 1/4W F	R751	1-247-831-11	CARBON	1K 5% 1/4W
R666	1-234-182-11	ENCAPSULATED COMPONENT	0.22X2 5W	R752	1-249-439-11	CARBON	68K 5% 1/4W
R667	1-249-393-11	CARBON	10 5% 1/4W F	R753	1-249-421-11	CARBON	2.2K 5% 1/4W
R668	1-249-389-11	CARBON	4.7 5% 1/4W F	R754	1-249-439-11	CARBON	68K 5% 1/4W
R669	1-247-847-11	CARBON	4.7K 5% 1/4W	R755	1-247-863-11	CARBON	22K 5% 1/4W
R671	1-247-850-11	CARBON	6.2K 5% 1/4W	R756	1-247-863-11	CARBON	22K 5% 1/4W
R672	1-249-419-11	CARBON	1.5K 5% 1/4W	R757	1-249-431-11	CARBON	15K 5% 1/4W
R673	1-247-871-11	CARBON	47K 5% 1/4W	R758	1-247-843-11	CARBON	3.3K 5% 1/4W
R674	1-249-431-11	CARBON	15K 5% 1/4W	R760	1-249-421-11	CARBON	2.2K 5% 1/4W
R675	1-247-863-11	CARBON	22K 5% 1/4W	R761	1-249-440-11	CARBON	82K 5% 1/4W
R676	1-247-863-11	CARBON	22K 5% 1/4W	R763	1-249-414-11	CARBON	560 5% 1/4W
R677	1-249-431-11	CARBON	15K 5% 1/4W	R764	1-249-405-11	CARBON	100 5% 1/4W F
R680	1-247-863-11	CARBON	22K 5% 1/4W	R765	1-249-405-11	CARBON	100 5% 1/4W F
R681	1-247-843-11	CARBON	3.3K 5% 1/4W	R766	1-234-182-11	ENCAPSULATED COMPONENT	0.22X2 5W
R690	1-247-887-00	CARBON	220K 5% 1/4W	R767	1-249-393-11	CARBON	10 5% 1/4W F
△ R691	1-216-452-11	METAL OXIDE	180 5% 2W F	R768	1-249-389-11	CARBON	4.7 5% 1/4W F
△ R692	1-215-888-00	METAL OXIDE	220 5% 2W F (DE497P)	R769	1-247-847-11	CARBON	4.7K 5% 1/4W
△ R692	1-215-889-00	METAL OXIDE	330 5% 2W F (K4800P/K5800P)	R770	1-247-871-11	CARBON	47K 5% 1/4W
R693	1-249-429-11	CARBON	10K 5% 1/4W	R771	1-247-850-11	CARBON	6.2K 5% 1/4W
R694	1-249-429-11	CARBON	10K 5% 1/4W	R772	1-249-419-11	CARBON	1.5K 5% 1/4W
R695	1-249-429-11	CARBON	10K 5% 1/4W	R773	1-247-871-11	CARBON	47K 5% 1/4W
R696	1-249-435-11	CARBON	33K 5% 1/4W	R775	1-249-439-11	CARBON	68K 5% 1/4W
R698	1-247-871-11	CARBON	47K 5% 1/4W	R778	1-249-431-11	CARBON	15K 5% 1/4W
R699	1-247-895-00	CARBON	470K 5% 1/4W	R780	1-249-429-11	CARBON	10K 5% 1/4W
R701	1-247-831-11	CARBON	1K 5% 1/4W	R791	1-247-847-11	CARBON	4.7K 5% 1/4W
R702	1-249-439-11	CARBON	68K 5% 1/4W	△ R792	1-215-868-00	METAL OXIDE	680 5% 1W F
R703	1-249-421-11	CARBON	2.2K 5% 1/4W	R793	1-249-404-00	CARBON	82 5% 1/4W F
R704	1-249-439-11	CARBON	68K 5% 1/4W	△ R794	1-215-868-00	METAL OXIDE	680 5% 1W F
R710	1-249-421-11	CARBON	2.2K 5% 1/4W	R802	1-249-409-11	CARBON	220 5% 1/4W F
				R803	1-249-389-11	CARBON	4.7 5% 1/4W F

The components identified by mark △ or dotted line with mark △ are critical for safety. Replace only with part number specified.

Les composants identifiés par une marque △ sont critiques pour la sécurité. Ne les remplacer que par une pièce portant le numéro spécifié.

STR-DE497P/K4800P/K5800P

MAIN	POWER	STANDBY
-------------	--------------	----------------

Ref. No.	Part No.	Description	Remark
RR11	1-249-393-11	CARBON	10 5% 1/4W F (DE497P)
RR12	1-249-393-11	CARBON	10 5% 1/4W F (DE497P)
RR13	1-249-393-11	CARBON	10 5% 1/4W F (DE497P)
RR14	1-249-393-11	CARBON	10 5% 1/4W F (DE497P)
RR15	1-249-393-11	CARBON	10 5% 1/4W F (DE497P)
< RELAY >			
RY501	1-755-421-11	RELAY (12V)	
RY560	1-755-267-11	RELAY	
RY601	1-755-421-11	RELAY (12V)	
RY701	1-755-421-11	RELAY (12V)	
RY791	1-755-421-11	RELAY (12V)	
< TERMINAL BOARD >			
TM601	1-694-785-11	TERMINAL BOARD (SPEAKERS SURROUND)	
TM602	1-694-805-11	TERMINAL BOARD (SPEAKERS FRONT,CENTER)	

	1-861-045-11	POWER BOARD	*****
< RESISTOR >			
R124	1-247-847-11	CARBON	4.7K 5% 1/4W
< SWITCH >			
S122	1-771-410-21	SWITCH, TACTILE (DIMMER)	
S123	1-771-410-21	SWITCH, TACTILE (DISPLAY)	
S152	1-771-410-21	SWITCH, TACTILE (I/⌂)	

A-4750-409-A	STANDBY BOARD, COMPLETE (DE497P)		
A-4750-608-A	STANDBY BOARD, COMPLETE (K4800P/K5800P)		

	1-533-217-41	HOLDER, FUSE	
< CAPACITOR >			
C801	1-126-947-11	ELECT	47uF 20% 35V
C802	1-126-947-11	ELECT	47uF 20% 35V
C813	1-164-159-11	CERAMIC	0.1uF 50V
C814	1-164-159-11	CERAMIC	0.1uF 50V
C815	1-126-943-11	ELECT	2200uF 20% 25V
C816	1-126-942-61	ELECT	1000uF 20% 25V
C820	1-164-159-11	CERAMIC	0.1uF 50V
C821	1-164-159-11	CERAMIC	0.1uF 50V
C822	1-126-947-11	ELECT	47uF 20% 35V
C823	1-126-936-11	ELECT	3300uF 20% 16V
C830	1-164-159-11	CERAMIC	0.1uF 50V
C831	1-164-159-11	CERAMIC	0.1uF 50V
C920	1-164-159-11	CERAMIC	0.1uF 50V
C921	1-164-159-11	CERAMIC	0.1uF 50V
C923	1-126-959-11	ELECT	0.47uF 20% 50V
C950	1-126-936-11	ELECT	3300uF 20% 16V

Ref. No.	Part No.	Description	Remark
< CONNECTOR >			
CNP802	1-779-977-11	PIN, CONNECTOR 6P	
CNP804	1-691-767-11	PLUG (MICRO CONNECTOR) 5P	
CNP901	1-564-321-00	PIN, CONNECTOR (3.96mm PITCH) 2P	
CNP902	1-794-577-21	PIN, CONNECTOR (POWER) 2P	
CNP903	1-564-506-11	PLUG, CONNECTOR 3P	
CNP905	1-793-673-11	CONNECTOR, BOARD TO BOARD 7P	
CNP912	1-779-978-11	PIN, CONNECTOR 3P	
< DIODE >			
D801	8-719-933-95	DIODE HZS20-1L	
D804	8-719-068-28	DIODE HZ6.8BP-TK	
D812	6-500-522-11	DIODE 10EDB40-TA2B5	
D813	6-500-522-11	DIODE 10EDB40-TA2B5	
D814	6-500-522-11	DIODE 10EDB40-TA2B5	
D815	6-500-522-11	DIODE 10EDB40-TA2B5	
D820	6-500-522-11	DIODE 10EDB40-TA2B5	
D821	6-500-522-11	DIODE 10EDB40-TA2B5	
D822	6-500-522-11	DIODE 10EDB40-TA2B5	
D823	6-500-522-11	DIODE 10EDB40-TA2B5	
D901	8-719-991-33	DIODE 1SS133T-77	
D910	6-500-522-11	DIODE 10EDB40-TA2B5	
D911	6-500-522-11	DIODE 10EDB40-TA2B5	
D912	6-500-522-11	DIODE 10EDB40-TA2B5	
D913	6-500-522-11	DIODE 10EDB40-TA2B5	
D914	8-719-991-33	DIODE 1SS133T-77	
D915	8-719-991-33	DIODE 1SS133T-77	
< EARTH TERMINAL >			
* G901	1-537-738-21	TERMINAL, EARTH (K4800P/K5800P)	
< TRANSISTOR >			
Q801	8-729-140-97	TRANSISTOR 2SB734-34	
Q901	8-729-119-79	TRANSISTOR 2SC2785-FEK	
Q921	8-729-119-79	TRANSISTOR 2SC2785-FEK	
< RESISTOR >			
R804	1-249-429-11	CARBON	10K 5% 1/4W
R806	1-247-863-11	CARBON	22K 5% 1/4W
△ R810	1-243-634-11	FUSIBLE	0.22 5% 1/2W F
△ R812	1-243-634-11	FUSIBLE	0.22 5% 1/2W F
△ R901	1-219-237-11	SOLID	3.3M 20% 1/2W F (US,CND)
R902	1-247-871-11	CARBON	47K 5% 1/4W
R903	1-247-847-11	CARBON	4.7K 5% 1/4W
R904	1-249-381-11	CARBON	1 5% 1/4W F
△ R910	1-243-635-11	FUSIBLE	0.33 5% 1/2W F
R921	1-247-871-11	CARBON	47K 5% 1/4W
R922	1-249-435-11	CARBON	33K 5% 1/4W
R923	1-249-429-11	CARBON	10K 5% 1/4W
< RELAY >			
△ RY901	1-755-276-31	RELAY, POWER	
< TRANSFORMER >			
△ T902	1-435-281-11	TRANSFORMER, POWER (US,CND)	

The components identified by mark △ or dotted line with mark △ are critical for safety. Replace only with part number specified.	Les composants identifiés par une marque △ sont critiques pour la sécurité. Ne les remplacer que par une pièce portant le numéro spécifié.
--	--

STANDBY

TUNING

VIDEO

Ref. No.	Part No.	Description	Remark		
△ T902	1-435-282-11	TRANSFORMER, POWER (AEP,UK)	*****		
	1-861-044-11	TUNING BOARD	*****		
		< RESISTOR >			
R132	1-247-831-11	CARBON	1K	5%	1/4W
R133	1-249-421-11	CARBON	2.2K	5%	1/4W
R134	1-249-421-11	CARBON	2.2K	5%	1/4W
R135	1-247-847-11	CARBON	4.7K	5%	1/4W
R136	1-249-429-11	CARBON	10K	5%	1/4W
		< SWITCH >			
S131	1-771-410-21	SWITCH, TACTILE (TUNING -)			
S132	1-771-410-21	SWITCH, TACTILE (FM MODE)			
S133	1-771-410-21	SWITCH, TACTILE (MEMORY)			
S134	1-771-410-21	SWITCH, TACTILE (PRESET TUNING -)			
S135	1-771-410-21	SWITCH, TACTILE (PRESET TUNING +)			
S151	1-771-410-21	SWITCH, TACTILE (TUNING +)	*****		
	A-4750-410-A	VIDEO BOARD, COMPLETE	*****		
		< CAPACITOR >			
C200	1-128-805-11	CERAMIC	47PF	5%	50V
C201	1-128-805-11	CERAMIC	47PF	5%	50V
C206	1-126-964-11	ELECT	10uF	20%	50V
C207	1-126-964-11	ELECT	10uF	20%	50V
C208	1-126-964-11	ELECT	10uF	20%	50V
C210	1-126-964-11	ELECT	10uF	20%	50V
C213	1-126-934-11	ELECT	220uF	20%	16V
C214	1-164-159-11	CERAMIC	0.1uF		50V
C215	1-164-159-11	CERAMIC	0.1uF		50V
C248	1-128-825-11	CERAMIC	0.0022uF	5%	50V
C809	1-126-934-11	ELECT	220uF	20%	16V
C824	1-164-159-11	CERAMIC	0.1uF		50V
C825	1-164-159-11	CERAMIC	0.1uF		50V
		< CONNECTOR >			
CNP156	1-691-765-11	PLUG (MICRO CONNECTOR) 3P			
CNS250	1-569-315-11	SOCKET, CONNECTOR 5P			
		< IC >			
IC203	8-759-333-84	IC NJM2279D			
IC804	8-759-701-65	IC NJM79M05FA			
IC807	8-759-231-53	IC TA7805S			
		< JACK >			
J200	1-794-978-11	JACK, PIN 3P (VIDEO 1 VIDEO OUT, VIDEO2 VIDEO IN,DVD VIDEO IN)			
J201	1-815-043-11	JACK, PIN 2P (MONITOR VIDEO OUT, VIDEO 1 VIDEO IN)			
		< RESISTOR >			
R200	1-247-804-11	CARBON	75	5%	1/4W
R201	1-247-804-11	CARBON	75	5%	1/4W
R218	1-247-804-11	CARBON	75	5%	1/4W

Ref. No.	Part No.	Description	Remark		
R220	1-247-804-11	CARBON	75	5%	1/4W
R221	1-247-804-11	CARBON	75	5%	1/4W
		MISCELLANEOUS	*****		
53	1-773-114-11	WIRE (FLAT TYPE) (19 CORE)			
102	1-575-662-31	WIRE (FLAT TYPE) (5 CORE)			
103	1-769-937-11	WIRE (FLAT TYPE) (11 CORE)	(K4800P/K5800P)		
103	1-773-001-11	WIRE (FLAT TYPE) (15 CORE)	(DE497P)		
△ 106	1-777-071-23	CORD, POWER (AEP,UK)			
△ 106	1-783-820-11	CORD, POWER (US,CND)			
△ F901	1-532-503-51	FUSE (T1.6AL/250V) (AEP,UK)			
△ F901	1-533-452-12	FUSE, GLASS TUBE (DIA.5) (4A/125V)	(US,CND)		
Q503	8-749-010-25	TRANSISTOR MN2488-OPY-M			
Q504	8-749-010-26	TRANSISTOR MP1620-OPY-M			
Q603	8-749-010-25	TRANSISTOR MN2488-OPY-M			
Q604	8-749-010-26	TRANSISTOR MP1620-OPY-M			
Q653	8-749-010-25	TRANSISTOR MN2488-OPY-M			
Q654	8-749-010-26	TRANSISTOR MP1620-OPY-M			
Q703	8-749-010-25	TRANSISTOR MN2488-OPY-M			
Q704	8-749-010-26	TRANSISTOR MP1620-OPY-M			
Q753	8-749-010-25	TRANSISTOR MN2488-OPY-M			
Q754	8-749-010-26	TRANSISTOR MP1620-OPY-M			
△ T901	1-443-185-11	TRANSFORMER, POWER (K4800P:US,CND)			
△ T901	1-443-211-11	TRANSFORMER, POWER (AEP,UK)			
△ T901	1-443-248-11	TRANSFORMER, POWER (K5800P:US)			
TN1	1-693-577-13	TUNER PACK (ANTENNA) (K5800P)			
TN1	1-693-577-21	TUNER PACK (ANTENNA) (K4800P)			
TN1	1-693-578-13	TUNER PACK (ANTENNA) (DE497P)			

The components identified by mark △ or dotted line with mark △ are critical for safety. Replace only with part number specified.

Les composants identifiés par une marque △ sont critiques pour la sécurité. Ne les remplacer que par une pièce portant le numéro spécifié.

