

Dieter's Nixie Tube Data Archive

This file is a part of Dieter's Nixie- and display tubes data archive

If you have more datasheets, articles, books, pictures or other information about Nixie tubes or other display devices please let me know.

Thank you!

Document in this file	Article about Z550M Pixie tube from the "Philips Technical Review": "Electronic Applications Vol. 21, No. 3". Thanks to Dr. Ir. Ronald Dekker from Philips Research The Netherlands for preparing this article!
Display devices in this document	Z550M

621.387:621.374.32

A Decade Indicator Tube for Transistorised Scalers

The need for a simple, easily readable indicator tube, which can be operated by a low-energy signal of only a few volts, has led to the development of the Type Z 550 M gas-discharge decade indicator tube. This tube, the operation of which is described below, can conveniently be controlled by the small signals which switching transistors are capable of delivering, the current required for giving a clear glow discharge being taken from a separate uncontrolled supply source.

Introduction

For counting electrical pulses at a rate exceeding approximately 10 pulses per second, such as is required for monitoring radioactivity and for supervising a great variety of industrial processes, electro-mechanical registers fail due to their inevitable inertia. The solution for counting pulses at a rate of up to 10^7 pulses per second or even higher therefore consists in using electronic counters.

The various types of electronic counter hitherto available all have the common feature that they consist of a sequence of scalars (which may be either of the binary or of the decade type) and that provision is made for giving a visual indication of the total number of pulses counted. For the last scalar, which counts for example the thousands, this may be achieved by connecting an electro-mechanical register to the preceding stage, provided the counting rate of this scalar is sufficiently low, but as a rule it will be required also to know the exact number of pulses counted by the preceding scalars, for which such registers are too slow.

There are in principle two fundamentally different solutions to this problem, namely:

- (1) the use of electron tubes, which, in addition to scaling, give a visual indication, or
- (2) the use of separate neon indicators which are controlled by the individual scalars.

In the first category are the gas-filled cold-cathode trigger tubes and ring-electrode scalars in which the glow discharge gives an indication, and the high-vacuum decade counter tube EIT¹ in which an electron beam impinging on a fluorescent screen gives the desired information. In gas-filled tubes an upper limit (approximately 3000 pulses per second) is set to the counting rate by the deionisation time, whereas with the decade counter tube EIT the associated circuitry limits the counting rate in practice to approximately 100 000 pulses per second at the utmost².

In counters from which an exceptionally high counting rate is demanded, recourse must therefore be had to the second solution, in which separate

This article is based on research by *Th. P. J. Botden*, Philips' Research Laboratories and *S. M. Frouws*, Development Laboratory Gas-Discharge Tubes, Eindhoven.

¹) The EIT Decade Counter Tube, *Electronic Appl.* **14**, p. 13, 1953 (No. 1).

²) A Decade Counter Stage with a Counting Rate of 100 000 Pulses per Second, *Electronic Appl.* **15**, p. 34, 1954 (No. 3).

devices are used for scaling and for indicating the number of counts.

A high counting rate is, however, not the only reason which necessitates the use of a separate indication device, for the scaler will be unable to indicate the number of counts when this is equipped with transistors which, though offering substantial advantages (for example small dimensions and low power consumption), are by nature unable to give a visual indication. As far as the speed of operation is concerned, the performance of adequately designed transistor circuits differs little from that of the best scalers equipped with electron tubes. They are, however, unable to deliver a signal of sufficient amplitude and energy to ignite any type of neon indicator tube hitherto available, nor can they provide the current required to produce a clearly visible glow discharge in these tubes without the scaling operation being jeopardised.

Discussion of the Gas Discharge

Before dealing with the operation of the Type Z 550 M indicator tube, it will be useful to discuss the mechanism of a discharge between two electrodes in a gaseous atmosphere in general. Fig. 1 shows the voltage versus current characteristic. In the region *AC* (Townsend discharge) the voltage is substantially independent of the current and roughly equal to the ignition voltage V_{ign} . In the region *BC* the voltage starts to decrease as the current increases, and this continues until the region *DE* of the normal glow discharge is reached. In this region the maintaining voltage V_m is also practically independent of the current, but it is considerably lower than the ignition voltage V_{ign} . The

The number of counts could of course be stored in a memory and extracted at a later time, as is customary in electronic computers, but this method would be far too cumbersome and expensive for a simple electronic counter.

Research was therefore carried out with the object of developing an indicator tube which can be controlled by signals of small amplitude and which draws only very weak currents from the control circuit.

These investigations have resulted in the recently introduced decade indicator tube Z 550 M, which has ten cathodes arranged in a circle and a common anode. In this tube the glow discharge is maintained by a separate supply source and can be transferred from one cathode to another by a signal of only 5 V and less than 50 μ A, such as can conveniently be supplied by a transistorised scaler.

transitional region *CD*, which is neither a Townsend discharge nor a glow discharge, is by nature unstable since the voltage decreases as the current increases. Beyond the normal glow discharge the region *EF* of the anomalous glow discharge begins. The region *FHG* (arc discharge) lies beyond the permissible ratings of the Z 550 M and will therefore be disregarded here.

The peculiar form of this graph may be explained as follows. If a fairly low voltage V_a is applied between the anode and cathode a minute current will start to flow. The magnitude of this current depends on the number of charge carriers, created per time unit by some external cause (ionising

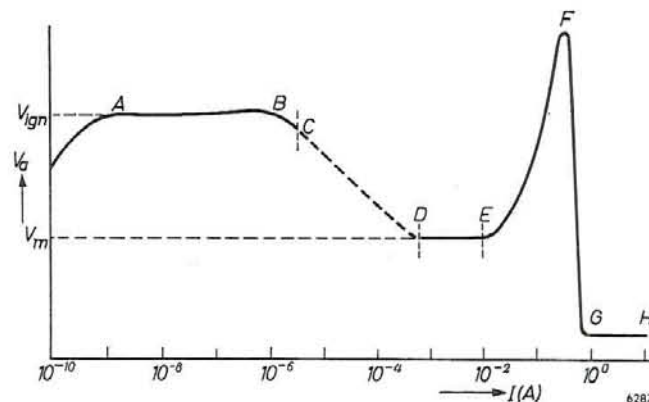

Fig. 1. Current-voltage characteristic of a gas discharge. The region *AC* corresponds to the Townsend discharge, the region *DE* to a normal glow discharge, and the region *EF* to an anomalous glow discharge. The arc-discharge region *FGH* is beyond the ratings of the indicator tube. The auxiliary discharge corresponds to the transitional region *CD*, the starter current being limited to such a low value that the region of glow discharge (*DE*) cannot be reached.

agent). The electrons are generated by two mechanisms: they result either from electrons which travel towards the anode and collide with gas atoms, or from ions arriving at the cathode. When the applied voltage is increased the number of electrons thus formed also increases, and the mechanism continues until at *A* the current intensity is such that owing to the avalanche effect at $V_a = V_{ign}$, the discharge becomes self-sustaining; the discharge then continues even if the external source of electrons is removed. At a further increase of the current a space charge of positive ions begins to form close

to the cathode. This affects the field distribution to such an extent that a lower voltage is sufficient for producing the number of ions that is required for drawing a certain current. Beyond this transitional region *CD* the discharge is characterised by the occurrence of a luminous sheath close to the cathode (glow discharge) and a substantially constant current density and maintaining voltage V_m . When the current is subsequently increased beyond the value corresponding to the available cathode area, the maintaining voltage will necessarily also increase (region *DE*, anomalous discharge).

Type Z 550 M Indicator Tube

Principle of Operation

Fig. 2 shows the arrangement of the electrodes of the Type Z 550 M indicator tube. The ten approximately trapezoidal plates *k* act as emissive cathodes.

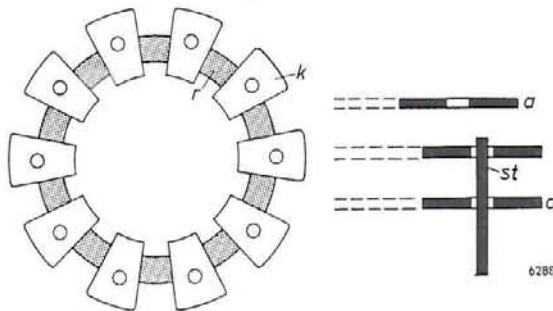

Fig. 2. Schematic representation of the electrode arrangement in the Type Z 550 M indicator tube.

They are mounted on a ring-shaped conducting support *r*, the shaded sections of which are coated with a material having a high work function compared with the cathodes *k* to reduce their electronic emission. A short distance above and below the cathodes annular anodes *a* are mounted. Ten wire electrodes *st*, the starters, protrude through holes in the lower anode ring and in each of the cathode sections. In the upper anode ring the figures from 0 to 9 are cut out, so that when a glow discharge is initiated by means of one of the starters, the figure facing the corresponding cathode clearly stands out.

Fig. 3 shows an exploded view of the electrode system and Fig. 4 photographs of the complete tube.

The emissive cathode sections have been "sputtered" during the manufacturing process to obtain a clean cathode surface, whilst the sputtered material settled on the glass envelope prevents contamination of the gas, and thus ensures stable operation. The tube is filled with neon to which a small

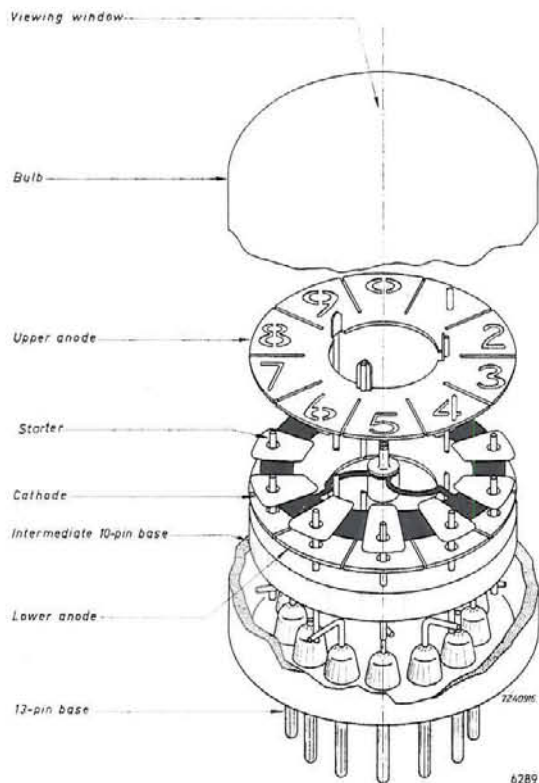

Fig. 3. Exploded view of the indicator tube.

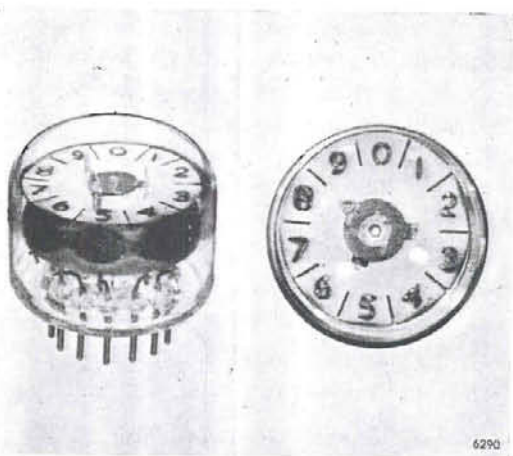

Fig. 4. Photographs of the Type Z 550 M indicator tube.

percentage of argon is added for reasons to be explained later.

The tube is fed with an unsmoothed rectified voltage (see Fig. 5), so that with half-wave rectification, the supply voltage rises to a maximum and drops to zero again once in every mains cycle. When the supply voltage reaches a certain value, a glow discharge is initiated which extinguishes again as soon as this voltage drops below the maintaining value. The glow discharge is thus obviously ignited and extinguished twice per cycle when full-wave rectification is employed.

As can be seen from Fig. 5, the starters are at anode potential as long as there is no discharge. However, as the distance between each cathode and its associated starter is much smaller than that between the cathode and the anodes, a discharge

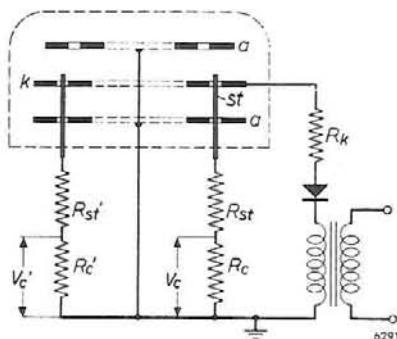

Fig. 5. Circuit diagram of the indicator tube (only two of the ten starters are indicated). a - anodes (earthed), k - cathodes, st - starters, V_c - control voltage. The current of the main discharge is limited by the resistor R_k , that of the auxiliary discharge by the resistors R_c and R_{st} , the latter having a much higher value.

between cathode and starter will be initiated before the supply voltage has risen to the value at which a discharge between cathode and anode is established. When, therefore, the supply voltage progressively rises from zero, the first effect will be the initiation of an auxiliary discharge between one of the cathodes and its starter.

The operation of the Type Z 550 M indicator tube is based on the fact that an auxiliary discharge between one of the cathodes and its starter reduces the required anode ignition voltage $V_{a\text{ign}}$ between this cathode and the anode to such an extent that the main discharge is also established at this cathode. It thus suffices to make provision for an auxiliary discharge to be established at the desired cathode to ensure that the main discharge occurs at the corresponding figure.

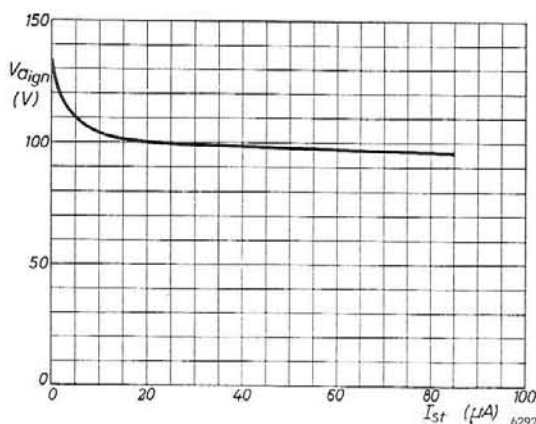

Fig. 6. Ignition voltage $V_{a\text{ign}}$ of the main discharge as a function of the current I_{st} of the auxiliary discharge for one of the cathode-starter positions.

This main discharge causes the anode potential to drop suddenly to the maintaining voltage V_m which is below the lowest ignition voltage at any other cathode, so that no discharge can be initiated elsewhere. In other words, "first come, first served" applies, at any rate as far as that particular cycle of the supply voltage is concerned.

The dependence of $V_{a\text{ign}}$ on the starter current I_{st} is plotted in Fig. 6 for one of the starter-cathode positions. It is seen that when the starter is disconnected ($I_{st} = 0$) the voltage required for initiating the main discharge is approximately 135 V, but at a starter current of, say, $I_{st} = 10 \mu\text{A}$, this voltage is reduced to approximately 105 V, which is mainly due to positive and negative charge carriers dif-

fusing from the auxiliary discharge to the space between this cathode and the anode. If, therefore, at a particular cathode, a starter current of this value is made to flow, the main discharge from that cathode is initiated in advance of that from the other cathodes by an amount corresponding roughly to the time the supply voltage takes to rise from 105 V to 135 V. As will be shown later, this obviously imposes certain requirements on the rise time of this voltage.

The cathode at which the auxiliary discharge is initiated can be selected by raising the voltage at the desired starter slightly above that of the others (and of the anodes). This may be done by applying a small positive control voltage V_c across resistor R_c . The corresponding starter then reaches the ignition voltage prior to the others, so that the discharge occurs at the desired position. If the control voltage V_c is transferred to another starter the re-ignition will take place at the new starter-cathode combination at the next (half) cycle, and so on.

The reason for employing an unsmoothed supply voltage will now be clear, namely that, in order to transfer the discharge from one cathode to another, the discharge must first be extinguished by reduction of the supply voltage to below the maintaining value, after which it must rise again gradually so that the desired starter can initiate the next discharge.

The control voltage, that is to say the additional impulse required to initiate the auxiliary discharge at a particular cathode, may be very much smaller than the maintaining voltage, since the total starter voltage need only be slightly higher than the voltages at the other starters. As will be explained in the next section, a control voltage having an amplitude of 5 V is all that is required with the Z 550 M, provided the supply voltage meets certain requirements.

A signal of only 5 V can conveniently be supplied by a transistor circuit. If this circuit is so designed that a signal is fed to starter st_1 for a count of 1, to the adjacent starter st_2 for a count of 2, and so forth, the tube will indicate the result of a count³. It should be recognised that it is immaterial whether the tube can follow the counting operation or not. Provided that after the completion

of a count the control signal is applied to the correct starter, the location of the discharge initiated at the next reignition of the tube will correspond to the final result of the count.

Since the power for the main discharge is not supplied by the control circuit, it is easy to ensure that this discharge will be sufficiently bright to provide a clear visual indication. By connecting the anode to earth, as shown in Fig. 5, one of the terminals of the transistorised control circuit can also be earthed, which greatly facilitates the circuit design.

Statistical Delay and Building-up Time

If a voltage slightly in excess of V_{ign} is applied across the electrodes, nothing will happen until a free electron is present at a suitable position in the space between the electrodes. This free electron will then of course move through the electric field towards the anode. In doing so, it will collide with gas atoms which are thus ionised, resulting in electrons being released which ionise other gas atoms, this action being cumulative. Because of the random character of the processes taking place in the gas and on the cathode, however, the "avalanche" thus produced may sometimes break off pending the arrival of a new initial electron. Not until the number of ions and electrons generated is extremely high is the chance of such an interruption eliminated. The time elapsing between the application of the voltage and the attainment of this condition is called the *statistical delay*.

Since random processes are involved here, this delay time may, in principle, have any value. To prevent the statistical delay being dependent on external causes, such as cosmic radiation or the photo-electric effect of daylight, a quantity of a harmless radioactive substance is included in the tube. A sufficient number of charge carriers is thus produced within a fraction of a second even if the tube were shielded completely from all external radiation.

The time elapsing between the formation of a stable avalanche and the moment that the avalanche effect ceases to increase in strength is called the *build-up time* of the discharge. At the commencement of the build-up time large numbers of ions

³ As will be shown in an article to be published shortly, this indicator tube can also count by itself at a rate of up to 1000 pulses per second, the counting pulses which are applied to the common input igniting the glow discharges in succession, so that the scaler can then be dispensed with.

and electrons are already present, so that the statistical fluctuations in the build-up time are so small that they cannot even be measured; the build-up time can thus be regarded as constant.

Minimum Value of the Control Voltage

If the starter "signal voltage" at which the auxiliary discharge is initiated were identical for all starters, the required control voltage V_c would be extremely small. After all, this voltage need only slightly exceed the maximum difference occurring between the starter ignition voltages for the ten starters.

It will therefore first be investigated what factors determine the actual differences occurring in the ignition voltage. The condition in which a discharge becomes self-sustaining, so that it supplies its own electron requirements, can be expressed by the equation:

$$\bar{\gamma} \{ \exp(\bar{\eta} V_{ign}) - 1 \} = 1$$

where $\bar{\gamma}$ is the average number of electrons released from the cathode by one gas ion and $\bar{\eta}$ is the average number of electrons produced by each electron in the gas per volt of traversed potential difference. The expression shows that V_{ign} depends both on $\bar{\gamma}$ and on $\bar{\eta}$. The value of $\bar{\gamma}$ depends on the velocity and kind of the ion (i.e. the nature of the gas) and on the condition of the cathode surface.

For the Type Z 550 M indicator tube any differences in the $\bar{\gamma}$ -value of the ten cathodes are therefore to be attributed exclusively to differing conditions of their surface, the composition of the gas obviously being the same for all cathodes. Since the cathodes are cleaned thoroughly by the sputtering process, the differences in the value of $\bar{\gamma}$ are minimised. Moreover, the gettering action of the sputtered molybdenum on the glass wall prevents contamination of the gas and maintains this favourable condition over a very long period.

In practice the ignition voltage V_{ign} does not depend very markedly on the value of $\bar{\gamma}$. This may be explained as follows. Since the exponential term in the above equation is very much larger than unity, this expression may to a good approximation be reduced to:

$$V_{ign} \approx -(\log_e \bar{\gamma}) / \bar{\eta},$$

which shows that the ignition voltage is pro-

portional to $\log_e \bar{\gamma}$. Since $\log_e \bar{\gamma}$ varies only slightly with $\bar{\gamma}$, any minor differences in $\bar{\gamma}$ that still exist after the cathode has been sputtered have scarcely any effect on the ignition voltage.

The ignition voltage does, however, depend largely on the value of $\bar{\eta}$, which is by no means constant. Its value depends in turn on the ratio of the electric force E to the gas pressure p , and for a given electrode configuration and voltage the electric force E is inversely proportional to the linear dimensions of the electrodes, that is to say inversely proportional to the distance d between two flat electrodes. In the case under consideration V_{ign} is thus a function of pd (Paschen law).

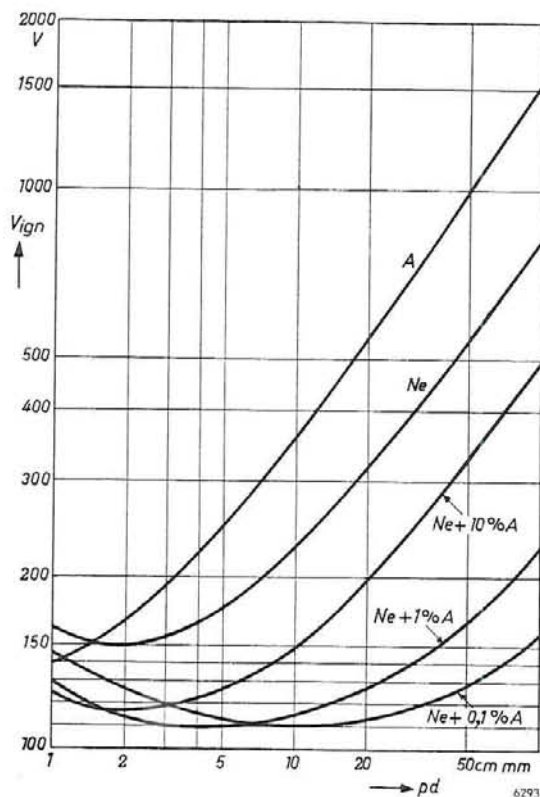

Fig. 7. Ignition voltage of various gas mixtures as a function of pd (Paschen curves), the electrodes being assumed to be flat molybdenum plates.

Fig. 7 shows this relation for various gas mixtures, the electrodes being assumed to consist of two flat molybdenum plates. This graph reveals that V_{ign} is almost constant within a wide range of pd in the case of a mixture of neon with a small percentage of argon. By filling the Type Z 550 M indicator tube with this mixture, the mutual differences between

the ignition voltages of the ten cathode-starter spaces are thus reduced to very small values notwithstanding unavoidable differences in the values of d .

Unfortunately, however, some spread is introduced by the fact that the auxiliary discharge is initiated at arbitrary points between the starter and cathode. This effect is, however, greatly reduced in the Z 550 M due to this tube having two anode plates, one above and one below the cathode.

The condition of the cathode surface and the electrode geometry are not the only factors that must be taken into account. The minimum amplitude of the control signal must also be chosen sufficiently large to make allowance for the fact that the ignition voltage of any one cathode-starter space may show certain fluctuations during operation of a particular tube. These fluctuations are related to one of the delay effects mentioned above and depend on the rise time of the pulses applied to the starter and anode. This subject is discussed at greater length in the next section, which deals with the relation between the minimum required amplitude of the control voltage and the properties (amplitude, frequency and waveform) of the supply voltage.

Supply Voltage

For the visual indication to be steady, the repetition frequency of the supply voltage need not exceed 25 pulses per second. At this frequency, however, the gas would have time to deionise almost completely every time the discharge is extinguished so that, when the supply voltage rises again, so few charge carriers would be left that it might depend on the statistical delay as to which of the starters will ignite first in the following cycle. In other words, the control voltage applied to one of the starters might be insufficient to ensure that this starter wins the race. For this reason the repetition frequency of the supply voltage should be at least 80 pulses per second.

On the other hand, the repetition frequency should not be chosen too high, for the higher this frequency, the larger will be the required control voltage. This is illustrated by Fig. 8 in which the minimum required control voltage $V_{c \text{ min}}$ has been plotted as a function of the repetition frequency f_{rep} of the supply voltage. By $V_{c \text{ min}}$ must be understood the difference between the starter and the anode

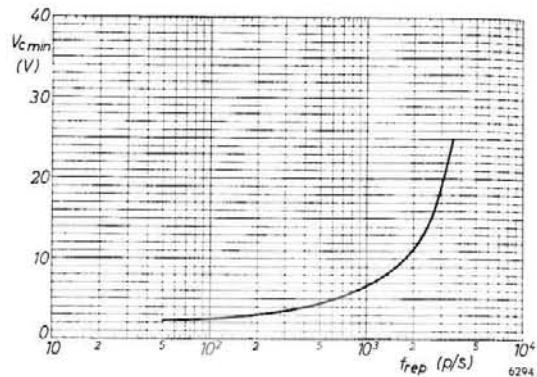

Fig. 8. Minimum required control voltage $V_{c \text{ min}}$ as a function of the repetition frequency f_{rep} of the supply voltage.

voltage which is just sufficient to displace the discharge.

This graph reveals that at f_{rep} up to 300 p/s $V_{c \text{ min}}$ remains substantially constant, but at higher frequencies $V_{c \text{ min}}$ increases rapidly. At $f_{rep} > 3000$ p/s the minimum control voltage $V_{c \text{ min}}$ exceeds 25 V.

This effect is related to the fact that after the gas discharge is extinguished it takes some time for the ions and electrons which form the plasma to disappear. If the voltage is applied again while some residual plasma is present, ignition will take place before the normal ignition voltage is reached. The shorter the time τ elapsing between the extinction of the discharge and the re-application of the supply voltage, the larger will be the decrease of the ignition voltage ΔV_{ign} . If τ becomes so small that the ignition voltage has dropped to the value of the maintaining voltage, the tube will always re-ignite at the same cathode.

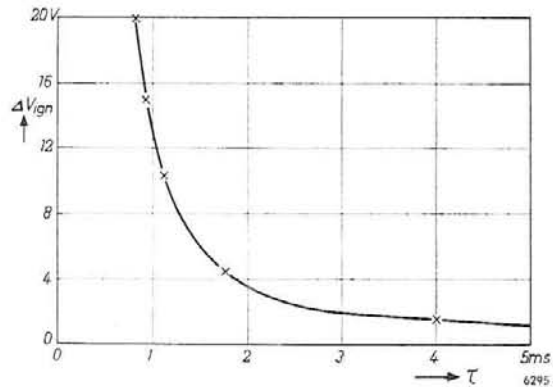

Fig. 9. Decrease of the ignition voltage ΔV_{ign} as a function of the time interval τ between the instant at which a discharge is initiated and that at which the preceding discharge was extinguished.

This effect was further investigated by measuring the decrease of the ignition voltage ΔV_{ign} as a function of the time τ . The results measured on an experimental tube are plotted in Fig. 9. At $\tau = 1$ ms the decrease of the ignition voltage, ΔV_{ign} , was as much as 13 V, and increased rapidly for even shorter values of τ . The agreement with the curve of Fig. 8 is reasonable, considering that the experiments were carried out under different conditions.

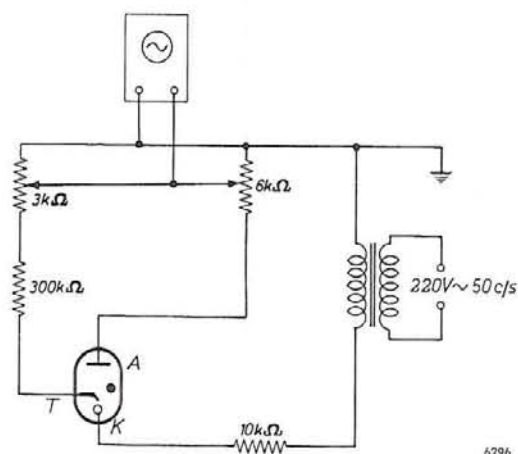

Fig. 10. Circuit used for recording the waveforms of the starter current, the main current, or the sum of certain selected fractions of each. The time base of the oscilloscope was adjusted so that the full picture width corresponded to $30 \mu\text{s}$; it was synchronised by triggering it with the same mains voltage as that supplied to the indicator tube.

In order to obtain some quantitative information on the effect of delay phenomena, the current in the main and auxiliary discharges and also the total current in both discharges together were displayed on an oscilloscope as functions of the time t after the application of the voltage. The basic circuit used for this purpose is shown in Fig. 10. The object of this investigation was to determine the statistical delay, and also to discover the rate at which the auxiliary discharge builds up, and the delay in the ignition of the main discharge.

Some of the oscillograms thus obtained are reproduced in Fig. 11. The curves of Fig. 11a, referring to the main discharge current, all have the same waveform, which points to a uniform build-up time, but they are slightly displaced with respect to each other. The mutual spread between the curves amounts to a few microseconds only, the extremes being $10 \mu\text{s}$ apart. The curves of Fig. 11b represent the sum of certain fractions of the currents of both the main and the auxiliary discharge,

obtained by suitable adjustment of the potentiometers in the circuit of Fig. 10. These adjustments were not the same for both recordings. From the shape of the curves it may be concluded that the first peak is due to the auxiliary discharge, and the second, less pronounced peak, to the main discharge. The ignition of the main discharge is seen to be less than $5 \mu\text{s}$ after the first peak. Thus the take-over time and also the build-up time (see Fig. 11a) were found to be virtually constant. The spread in the total delay time is therefore almost entirely due to the spread in the statistical delay.

From the results of these investigations it may be concluded that the effects involved here have no influence on the maximum permissible frequency of the supply voltage. In fact, the measured time intervals are roughly only 1% of the deionisation time.

The spread in the total delay, however, has some influence on the minimum required amplitude of the control voltage, as previously mentioned. In practice, the spread in this delay also causes a spread in the ignition voltage, which is equal to

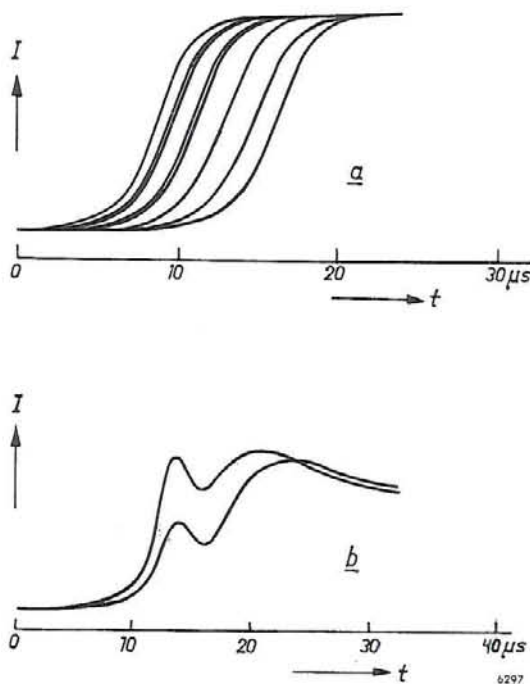

Fig. 11. (a) Oscillograms of the main discharge current. (b) Two oscillograms displaying the sum of the currents of the auxiliary and of the main discharges. For both curves the potentiometers in the circuit of Fig. 10 were so adjusted that the contribution of the auxiliary discharge current is exaggerated with respect to the main discharge current. The adjustments of the potentiometers were different in the two cases.

the delay multiplied by the derivative of the supply voltage with time when this reaches the value of the ignition voltage (approximately 130 V). This derivative increases with the amplitude of the supply voltage, the frequency remaining constant, and also with the frequency, the amplitude remaining constant. An idea of the magnitude of this effect is given by the following numerical example, using values encountered in practice. At a supply frequency of 50 p/s, an amplitude of 300 V and a difference in delay time of 10 μ s for two ignitions, the ignition voltages of these discharges differed in value by approximately 0.85 V. At a supply voltage amplitude of 150 V they differed only by approximately 0.35 V. Compared with a signal amplitude of a few volts, these amounts are not negligible.

It may thus be inferred that if the tube is fed with a square-wave voltage, the steepness of the leading edges must be less than approximately 10^5 V/s, since otherwise the minimum required control voltage would be considerably increased. For similar reasons the supply voltage should be free from "spikes".

In this connection it should also be recognised that the closer the electrode to which the discharge is to be transferred, the lower will be the minimum required control voltage. This is quite obvious, in view of the fact that the electrons which initiate the avalanche usually originate from the discharge that took place during the preceding pulse of the supply voltage. These electrons diffuse faster and in greater numbers to nearby electrodes than to more distant ones. In the case of the discharge on nearby electrodes the delay is therefore not only smaller, but also shows a smaller (absolute) spread, and hence gives a smaller spread in ignition voltage. It is due to this electron diffusion that the delay is as small as it is. If the tube has been switched off for some time, so that the first electron must originate from the radioactive substance incorporated in the tube, the delay may be appreciably longer. This does not of course prove troublesome in actual operation.

Visibility of the Discharge and Useful Life

The visibility of a glow discharge depends on the nature of the gas and on the current density of the discharge. The Type Z 550 M indicator tube is filled mainly with neon which, of the gases that are chemically not reactive in gas discharges, gives the largest light output.

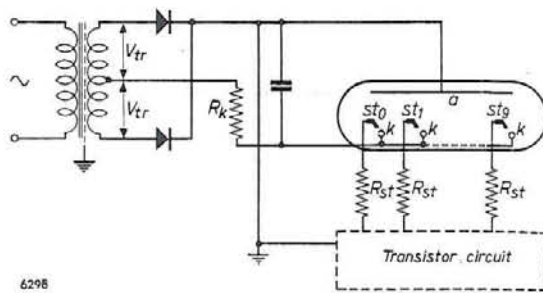

6298

Fig. 12. Practical circuit of the indicator tube controlled by a transistorised scaler.

The current density is roughly proportional to the square of the gas pressure, which has for this reason been chosen fairly high. The tube moreover works in the region of anomalous glow discharge (see Fig. 6), which further increases the luminance. For this purpose the surface area of the cathodes is kept as small as possible.

The brightness of the discharge is approximately 1200 cd/m² (current density 10 mA/cm²). This may be compared with the luminance of a 40 W fluorescent lamp, which is approximately 8000 cd/m². Partly because of its reddish colour, the glow discharge is still clearly visible in normal daylight.

Tests have shown that the properties of the tube remain remarkably constant, both after intensive use and after long storage. As in other cold-cathode glow-discharge tubes, the expected life of the Z 550 M tube is very long (more than 20 000 operating hours).

Fig. 12 shows the fundamental circuit of a Type Z 550 M indicator tube driven by a transistor circuit

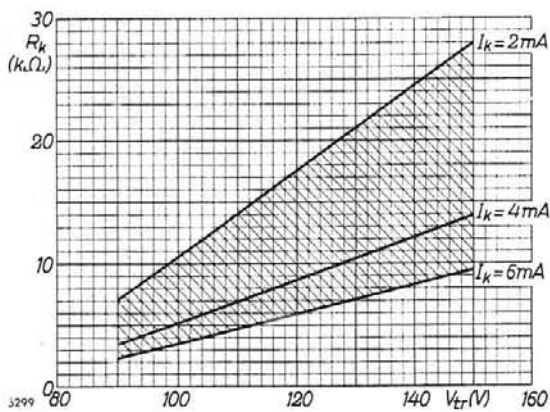

Fig. 13. The hatched area indicates the permissible values of the common cathode resistor R_k as a function of the secondary transformer voltage V_{tr} (cf. Fig. 12.).

(for example a scaler). The capacitor connected between the cathode and anode is necessary to prevent spikes, which may be present in the supply voltage, from upsetting the correct operation of the tube; a convenient value is 33 nF.

The required value of the common cathode resistor R_k depends on that of the transformer voltage, as shown by the graph of Fig. 13. It should

be so chosen that the tube operates within the hatched area.

To ensure the indication of a particular figure, the potential of the starter of that figure should be raised by a minimum of 5 V with respect to the remaining starters. The common starter bias potential may deviate by a maximum of ± 5 V from the anode potential.