



LG

Life's Good

North/Latin America
Europe/Africa
Asia/Oceania

Internal Use Only

<http://aic.lgservice.com>
<http://eic.lgservice.com>
<http://biz.lgservice.com>

LED TV

SERVICE MANUAL

CHASSIS : LD46B

MODEL : 55LB58 55LB58**-Z***
55LB580V 55LB580V-TA

CAUTION

BEFORE SERVICING THE CHASSIS,
READ THE SAFETY PRECAUTIONS IN THIS MANUAL.

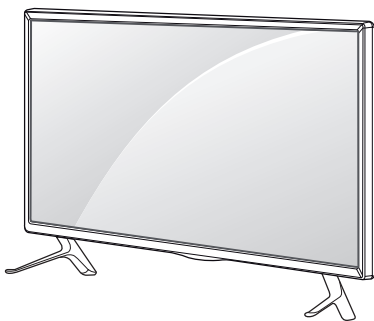

CONTENTS

CONTENTS	2
SAFETY PRECAUTIONS	3
SERVICING PRECAUTIONS.....	4
SPECIFICATION	6
ADJUSTMENT INSTRUCTION	10
BLOCK DIAGRAM	18
EXPLODED VIEW	19
SCHEMATIC CIRCUIT DIAGRAM	

SAFETY PRECAUTIONS

IMPORTANT SAFETY NOTICE

Many electrical and mechanical parts in this chassis have special safety-related characteristics. These parts are identified by \triangle in the Schematic Diagram and Exploded View.

It is essential that these special safety parts should be replaced with the same components as recommended in this manual to prevent Shock, Fire, or other Hazards.

Do not modify the original design without permission of manufacturer.

General Guidance

An **isolation Transformer should always be used** during the servicing of a receiver whose chassis is not isolated from the AC power line. Use a transformer of adequate power rating as this protects the technician from accidents resulting in personal injury from electrical shocks.

It will also protect the receiver and its components from being damaged by accidental shorts of the circuitry that may be inadvertently introduced during the service operation.

If any fuse (or Fusible Resistor) in this TV receiver is blown, replace it with the specified.

When replacing a high wattage resistor (Oxide Metal Film Resistor, over 1 W), keep the resistor 10 mm away from PCB.

Keep wires away from high voltage or high temperature parts.

Before returning the receiver to the customer,

always perform an **AC leakage current check** on the exposed metallic parts of the cabinet, such as antennas, terminals, etc., to be sure the set is safe to operate without damage of electrical shock.

Leakage Current Cold Check(Antenna Cold Check)

With the instrument AC plug removed from AC source, connect an electrical jumper across the two AC plug prongs. Place the AC switch in the on position, connect one lead of ohm-meter to the AC plug prongs tied together and touch other ohm-meter lead in turn to each exposed metallic parts such as antenna terminals, phone jacks, etc.

If the exposed metallic part has a return path to the chassis, the measured resistance should be between 1 M Ω and 5.2 M Ω .

When the exposed metal has no return path to the chassis the reading must be infinite.

An other abnormality exists that must be corrected before the receiver is returned to the customer.

Leakage Current Hot Check (See below Figure)

Plug the AC cord directly into the AC outlet.

Do not use a line Isolation Transformer during this check.

Connect 1.5 K / 10 watt resistor in parallel with a 0.15 uF capacitor between a known good earth ground (Water Pipe, Conduit, etc.) and the exposed metallic parts.

Measure the AC voltage across the resistor using AC voltmeter with 1000 ohms/volt or more sensitivity.

Reverse plug the AC cord into the AC outlet and repeat AC voltage measurements for each exposed metallic part. Any voltage measured must not exceed 0.75 volt RMS which corresponds to 0.5 mA.

In case any measurement is out of the limits specified, there is possibility of shock hazard and the set must be checked and repaired before it is returned to the customer.

Leakage Current Hot Check circuit

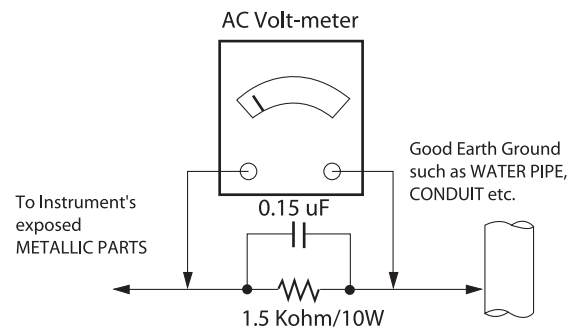

When 25A is impressed between Earth and 2nd Ground for 1 second, Resistance must be less than 0.1 Ω

*Base on Adjustment standard

SERVICING PRECAUTIONS

CAUTION: Before servicing receivers covered by this service manual and its supplements and addenda, read and follow the **SAFETY PRECAUTIONS** on page 3 of this publication.
NOTE: If unforeseen circumstances create conflict between the following servicing precautions and any of the safety precautions on page 3 of this publication, always follow the safety precautions. Remember: Safety First.

General Servicing Precautions

1. Always unplug the receiver AC power cord from the AC power source before;
 - a. Removing or reinstalling any component, circuit board module or any other receiver assembly.
 - b. Disconnecting or reconnecting any receiver electrical plug or other electrical connection.
 - c. Connecting a test substitute in parallel with an electrolytic capacitor in the receiver.
CAUTION: A wrong part substitution or incorrect polarity installation of electrolytic capacitors may result in an explosion hazard.
2. Test high voltage only by measuring it with an appropriate high voltage meter or other voltage measuring device (DVM, FETVOM, etc) equipped with a suitable high voltage probe. Do not test high voltage by "drawing an arc".
3. Do not spray chemicals on or near this receiver or any of its assemblies.
4. Unless specified otherwise in this service manual, clean electrical contacts only by applying the following mixture to the contacts with a pipe cleaner, cotton-tipped stick or comparable non-abrasive applicator; 10 % (by volume) Acetone and 90 % (by volume) isopropyl alcohol (90 % - 99 % strength)
CAUTION: This is a flammable mixture.
Unless specified otherwise in this service manual, lubrication of contacts is not required.
5. Do not defeat any plug/socket B+ voltage interlocks with which receivers covered by this service manual might be equipped.
6. Do not apply AC power to this instrument and/or any of its electrical assemblies unless all solid-state device heat sinks are correctly installed.
7. Always connect the test receiver ground lead to the receiver chassis ground before connecting the test receiver positive lead.
Always remove the test receiver ground lead last.
8. Use with this receiver only the test fixtures specified in this service manual.
CAUTION: Do not connect the test fixture ground strap to any heat sink in this receiver.

Electrostatically Sensitive (ES) Devices

Some semiconductor (solid-state) devices can be damaged easily by static electricity. Such components commonly are called Electrostatically Sensitive (ES) Devices. Examples of typical ES devices are integrated circuits and some field-effect transistors and semiconductor "chip" components. The following techniques should be used to help reduce the incidence of component damage caused by static by static electricity.

1. Immediately before handling any semiconductor component or semiconductor-equipped assembly, drain off any electrostatic charge on your body by touching a known earth ground. Alternatively, obtain and wear a commercially available discharging wrist strap device, which should be removed to prevent potential shock reasons prior to applying power to the unit under test.

2. After removing an electrical assembly equipped with ES devices, place the assembly on a conductive surface such as aluminum foil, to prevent electrostatic charge buildup or exposure of the assembly.
3. Use only a grounded-tip soldering iron to solder or unsolder ES devices.
4. Use only an anti-static type solder removal device. Some solder removal devices not classified as "anti-static" can generate electrical charges sufficient to damage ES devices.
5. Do not use freon-propelled chemicals. These can generate electrical charges sufficient to damage ES devices.
6. Do not remove a replacement ES device from its protective package until immediately before you are ready to install it. (Most replacement ES devices are packaged with leads electrically shorted together by conductive foam, aluminum foil or comparable conductive material).
7. Immediately before removing the protective material from the leads of a replacement ES device, touch the protective material to the chassis or circuit assembly into which the device will be installed.
CAUTION: Be sure no power is applied to the chassis or circuit, and observe all other safety precautions.
8. Minimize bodily motions when handling unpackaged replacement ES devices. (Otherwise harmless motion such as the brushing together of your clothes fabric or the lifting of your foot from a carpeted floor can generate static electricity sufficient to damage an ES device.)

General Soldering Guidelines

1. Use a grounded-tip, low-wattage soldering iron and appropriate tip size and shape that will maintain tip temperature within the range of 500 °F to 600 °F.
2. Use an appropriate gauge of RMA resin-core solder composed of 60 parts tin/40 parts lead.
3. Keep the soldering iron tip clean and well tinned.
4. Thoroughly clean the surfaces to be soldered. Use a mall wire-bristle (0.5 inch, or 1.25 cm) brush with a metal handle. Do not use freon-propelled spray-on cleaners.
5. Use the following unsoldering technique
 - a. Allow the soldering iron tip to reach normal temperature. (500 °F to 600 °F)
 - b. Heat the component lead until the solder melts.
 - c. Quickly draw the melted solder with an anti-static, suction-type solder removal device or with solder braid.
CAUTION: Work quickly to avoid overheating the circuit board printed foil.
6. Use the following soldering technique.
 - a. Allow the soldering iron tip to reach a normal temperature (500 °F to 600 °F)
 - b. First, hold the soldering iron tip and solder the strand against the component lead until the solder melts.
 - c. Quickly move the soldering iron tip to the junction of the component lead and the printed circuit foil, and hold it there only until the solder flows onto and around both the component lead and the foil.
CAUTION: Work quickly to avoid overheating the circuit board printed foil.
 - d. Closely inspect the solder area and remove any excess or splashed solder with a small wire-bristle brush.

IC Remove/Replacement

Some chassis circuit boards have slotted holes (oblong) through which the IC leads are inserted and then bent flat against the circuit foil. When holes are the slotted type, the following technique should be used to remove and replace the IC. When working with boards using the familiar round hole, use the standard technique as outlined in paragraphs 5 and 6 above.

Removal

1. Desolder and straighten each IC lead in one operation by gently prying up on the lead with the soldering iron tip as the solder melts.
2. Draw away the melted solder with an anti-static suction-type solder removal device (or with solder braid) before removing the IC.

Replacement

1. Carefully insert the replacement IC in the circuit board.
2. Carefully bend each IC lead against the circuit foil pad and solder it.
3. Clean the soldered areas with a small wire-bristle brush. (It is not necessary to reapply acrylic coating to the areas).

"Small-Signal" Discrete Transistor Removal/Replacement

1. Remove the defective transistor by clipping its leads as close as possible to the component body.
2. Bend into a "U" shape the end of each of three leads remaining on the circuit board.
3. Bend into a "U" shape the replacement transistor leads.
4. Connect the replacement transistor leads to the corresponding leads extending from the circuit board and crimp the "U" with long nose pliers to insure metal to metal contact then solder each connection.

Power Output, Transistor Device

Removal/Replacement

1. Heat and remove all solder from around the transistor leads.
2. Remove the heat sink mounting screw (if so equipped).
3. Carefully remove the transistor from the heat sink of the circuit board.
4. Insert new transistor in the circuit board.
5. Solder each transistor lead, and clip off excess lead.
6. Replace heat sink.

Diode Removal/Replacement

1. Remove defective diode by clipping its leads as close as possible to diode body.
2. Bend the two remaining leads perpendicular y to the circuit board.
3. Observing diode polarity, wrap each lead of the new diode around the corresponding lead on the circuit board.
4. Securely crimp each connection and solder it.
5. Inspect (on the circuit board copper side) the solder joints of the two "original" leads. If they are not shiny, reheat them and if necessary, apply additional solder.

Fuse and Conventional Resistor

Removal/Replacement

1. Clip each fuse or resistor lead at top of the circuit board hollow stake.
2. Securely crimp the leads of replacement component around notch at stake top.

3. Solder the connections.

CAUTION: Maintain original spacing between the replaced component and adjacent components and the circuit board to prevent excessive component temperatures.

Circuit Board Foil Repair

Excessive heat applied to the copper foil of any printed circuit board will weaken the adhesive that bonds the foil to the circuit board causing the foil to separate from or "lift-off" the board. The following guidelines and procedures should be followed whenever this condition is encountered.

At IC Connections

To repair a defective copper pattern at IC connections use the following procedure to install a jumper wire on the copper pattern side of the circuit board. (Use this technique only on IC connections).

1. Carefully remove the damaged copper pattern with a sharp knife. (Remove only as much copper as absolutely necessary).
2. Carefully scratch away the solder resist and acrylic coating (if used) from the end of the remaining copper pattern.
3. Bend a small "U" in one end of a small gauge jumper wire and carefully crimp it around the IC pin. Solder the IC connection.
4. Route the jumper wire along the path of the out-away copper pattern and let it overlap the previously scraped end of the good copper pattern. Solder the overlapped area and clip off any excess jumper wire.

At Other Connections

Use the following technique to repair the defective copper pattern at connections other than IC Pins. This technique involves the installation of a jumper wire on the component side of the circuit board.

1. Remove the defective copper pattern with a sharp knife. Remove at least 1/4 inch of copper, to ensure that a hazardous condition will not exist if the jumper wire opens.
2. Trace along the copper pattern from both sides of the pattern break and locate the nearest component that is directly connected to the affected copper pattern.
3. Connect insulated 20-gauge jumper wire from the lead of the nearest component on one side of the pattern break to the lead of the nearest component on the other side. Carefully crimp and solder the connections.
CAUTION: Be sure the insulated jumper wire is dressed so the it does not touch components or sharp edges.

SPECIFICATION

NOTE : Specifications and others are subject to change without notice for improvement.

1. Application range

This specification is applied to the LED TV used LD46B chassis.

2. Requirement for Test

Each part is tested as below without special appointment.

- 1) Temperature: 25 °C ± 5 °C(77 °F ± 9 °F), CST: 40 °C ± 5 °C
- 2) Relative Humidity: 65 % ± 10 %
- 3) Power Voltage
: Standard input voltage (AC 100-240 V~, 50/60 Hz)
* Standard Voltage of each products is marked by models.
- 4) Specification and performance of each parts are followed each drawing and specification by part number in accordance with BOM.
- 5) The receiver must be operated for about 20 minutes prior to the adjustment.

3. Test method

- 1) Performance: LGE TV test method followed
- 2) Demanded other specification
 - Safety : CE, IEC, CU specification
 - EMC : CE, IEC, CU

4. Model General Specification

No.	Item	Specification	Remarks
1	Market	EU(PAL Market-37Countries)	<p>DTV & Analog (Total 37 countries) DTV (MPEG2/4, DVB-T) : 29 countries Germany, Netherland, Switzerland, Hungary, Austria, Slovenia, Bulgaria, France, Spain, Italy, Belgium, Luxemburg, Greece, Czech, Croatia, Turkey, Morocco, Ireland, Latvia, Estonia, Lithuania, Poland, Portugal, Romania, Albania, Bosnia, Serbia, Slovakia, Beralus</p> <p>DTV (MPEG2/4, DVB-T2): 8 countries UK(Ireland), Sweden, Denmark, Finland, Norway, Ukraine, Kazakhstan, Russia</p> <p>DTV (MPEG2/4, DVB-C): 37 countries Germany, Netherland, Switzerland, Hungary, Austria, Slovenia, Bulgaria, France, Spain, Italy, Belgium, Russia, Luxemburg, Greece, Czech, Croatia, Turkey, Morocco, Ireland, Latvia, Estonia, Lithuania, Poland, Portugal, Romania, Albania, Bosnia, Serbia, Slovakia, Beralus, UK, Sweden, Denmark, Finland, Norway, Ukraine, Kazakhstan</p> <p>DTV (MPEG2/4,DVB-S): 30 countries Germany, Netherland, Switzerland, Hungary, Austria, Slovenia, Bulgaria, France, Spain, Italy, Belgium, Russia, Luxemburg, Greece, Czech, Croatia, Turkey, Morocco, Ireland, Latvia, Estonia, Lithuania, Poland, Portugal, Romania, Albania, Bosnia, Serbia, Slovakia, Beralus</p> <p>Supported satellite : 22 satellites HISPASAT 1C/1D, ATLANTIC BIRD 2, NILESAT 101/102, ATLANTIC BIRD 3, AMOS 2/3, THOR 5/6, IRIUS 4, EUTELSAT-W3A, EUROBIRD 9A, EUTELSAT-W2A, HOTBIRD 6/8/9, EUTELSAT-SESAT, ASTRA 1L/H/M/KR, ASTRA 3A/3B, BADR 4/6, ASTRA 2D, EUROBIRD 3, EUTELSAT-W7, HELLASSAT 2, EXPRESS AM1, TURK-SAT 2A/3A, INTERSAT10</p>

No.	Item	Specification	Remarks
2	Broadcasting system	1) PAL-B/G 2) PAL-D/K 3) PAL-I 4) SECAM-L/L', D/K , B/G, I 5) DVB-T 6) DVB-C 7) DVB-T2 8) DVB-S/S2	MODEL NAME EU/CIS : T2/C/S2 - FHD "V", HD "U" T/C - FHD "0", HD "B" JA : T2/C/S2 – FHD "V" T/C Model : 7) DVB-T2, 8) DVB-S/S2, not support.
3	Program coverage	1) Digital TV - VHF, UHF - C-Band,Ku-Band 2) Analogue TV - VHF : E2 to E12 - UHF : E21 to E69 - CATV : S1 to S20 - HYPER : S21 to S47	C-Band*,Ku-Band* : Only T2/C/S2 Model.
4	Receiving system	Analog : Upper Heterodyne Digital : COFDM, QAM	<p>▶ DVB-T</p> <ul style="list-style-type: none"> - Guard Interval(Bitrate_Mbit/s) 1/4, 1/8, 1/16, 1/32 - Modulation : Code Rate QPSK : 1/2, 2/3, 3/4, 5/6, 7/8 16-QAM : 1/2, 2/3, 3/4, 5/6, 7/8 64-QAM : 1/2, 2/3, 3/4, 5/6, 7/8 <p>▶ DVB-T2 (Model : *L*V*-Z* (T2 only Model))</p> <ul style="list-style-type: none"> - Guard Interval(Bitrate_Mbit/s) 1/4, 1/8, 1/16, 1/32, 1/128, 19/128, 19/256, - Modulation : Code Rate QPSK : 1/2, 2/5, 2/3, 3/4, 5/6 16-QAM : 1/2, 2/5, 2/3, 3/4, 5/6 64-QAM : 1/2, 2/5, 2/3, 3/4, 5/6 256-QAM : 1/2, 2/5, 2/3, 3/4, 5/6 <p>▶ DVB-C</p> <ul style="list-style-type: none"> - Symbolrate : 4.0Msymbols/s to 7.2Msymbols/s - Modulation : 16QAM, 64-QAM, 128-QAM and 256-QAM <p>▶ DVB-S/S2</p> <ul style="list-style-type: none"> - symbolrate DVB-S2 (8PSK / QPSK) : 2 ~ 45Msymbol/s DVB-S (QPSK) : 2 ~ 45Msymbol/s - viterbi DVB-S mode : 1/2, 2/3, 3/4, 5/6, 7/8 DVB-S2 mode : 1/2, 2/3, 3/4, 3/5, 4/5, 5/6, 8/9, 9/10
5	Scart (1EA)	PAL, SECAM	Scart 1 Jack is Full scart and support ATV/DTV-OUT (not support DTV Auto AV)
6	Video Input RCA(1EA)	PAL, SECAM, NTSC4.43	4 System : PAL, SECAM, NTSC4.43, PAL60 Hybrid Type
7	Head phone out	Antenna, AV1, AV2, Component, HDMI1, HDMI2, HDMI3, USB1, USB2, USB3	
8	Component Input (1EA)	Y/Cb/Cr Y/Pb/Pr	Hybrid Type
9	HDMI Input (2EA)	HDMI1-DTV HDMI2-DTV HDMI3-DTV	HDMI1: PC support(HDMI version 1.3) Support HDCP
10	Audio Input (3EA)	DVI Audio Component/AV2 AV1	L/R Input.
11	SDPIF out (1EA)	SPDIF out	
12	USB (3EA)	EMF, DivX HD, For SVC (download)	JPEG, MP3, DivX HD
13	Ethernet Connect(1EA)	Ethernet Connect	

5. Component Video Input (Y, PB, PR)

No.	Resolution	H-freq(kHz)	V-freq(Hz)	Pixel clock
1.	720×480	15.73	60.00	SDTV, DVD 480i
2.	720×480	15.63	59.94	SDTV, DVD 480i
3.	720×480	31.47	59.94	480p
4.	720×480	31.50	60.00	480p
5.	720×576	15.625	50.00	SDTV, DVD 625 Line
6.	720×576	31.25	50.00	SDTV 576p
7.	1280×720	45.00	50.00	HDTV 720p
8.	1280×720	44.96	59.94	HDTV 720p
9.	1280×720	45.00	60.00	HDTV 720p
10.	1920×1080	31.25	50.00	HDTV 1080i
11.	1920×1080	33.75	60.00	HDTV 1080i
12.	1920×1080	33.72	59.94	HDTV 1080i
13.	1920×1080	56.250	50	HDTV 1080p
14.	1920×1080	67.5	60	HDTV 1080p

6. HDMI Input

6.1. DTV mode

No.	Resolution	H-freq(kHz)	V-freq.(Hz)	Pixel clock(MHz)
1	640*480	31.469 / 31.5	59.94/60	SDTV 480P
2	720*480	31.469 / 31.5	59.94 / 60	SDTV 480P
3	720*576	31.25	50	SDTV 576P
4	720*576	15.625	50	SDTV 576I
5	1280*720	37.500	50	HDTV 720P
6	1280*720	44.96 / 45	59.94 / 60	HDTV 720P
7	1920*1080	33.72 / 33.75	59.94 / 60	HDTV 1080I
8	1920*1080	28.125	50.00	HDTV 1080I
9	1920*1080	26.97 / 27	23.97 / 24	HDTV 1080P
10	1920*1080	28.125	25	HDTV 1080P
11	1920*1080	33.716 / 33.75	29.976 / 30.00	HDTV 1080P
12	1920*1080	56.250	50	HDTV 1080P
13	1920*1080	67.43 / 67.5	59.94 / 60	HDTV 1080P

6.2. PC mode

No.	Resolution	H-freq(kHz)	V-freq.(Hz)	Pixel clock(MHz)	Remarks
1	640 x 350 @70Hz	31.468	70.09	EGA	
2	720 x 400 @70Hz	31.469	70.08	DOS	
3	640 x 480 @60Hz	31.469	59.94	VESA(VGA)	
4	800 x 600 @60Hz	37.879	60.31	VESA(SVGA)	
5	1024 x 768 @60Hz	48.363	60.00	VESA(XGA)	
6	1152 x 864 @60Hz	54.348	60.053	VESA	
7	1280 x 1024 @60Hz	63.981	60.020	VESA(SXGA)	
8	1360 x 768 @60Hz	47.712	60.015	VESA(WXGA)	
9	1920 x 1080 @60Hz	67.5	60.00	WUXGA(Reduced Blanking)	

ADJUSTMENT INSTRUCTION

1. Application Range

This specification sheet is applied to all of the LED TV with LD46B chassis.

2. Designation

- (1) Because this is not a hot chassis, it is not necessary to use an isolation transformer. However, the use of isolation transformer will help protect test instrument.
- (2) Adjustment must be done in the correct order.
- (3) The adjustment must be performed in the circumstance of $25\text{ }^{\circ}\text{C} \pm 5\text{ }^{\circ}\text{C}$ of temperature and $65\% \pm 10\%$ of relative humidity if there is no specific designation.
- (4) The input voltage of the receiver must keep AC 100-240 V~, 50/60 Hz.
- (5) The receiver must be operated for about 5 minutes prior to the adjustment when module is in the circumstance of over 15.

In case of keeping module is in the circumstance of $0\text{ }^{\circ}\text{C}$, it should be placed in the circumstance of above $15\text{ }^{\circ}\text{C}$ for 2 hours.

In case of keeping module is in the circumstance of below $-20\text{ }^{\circ}\text{C}$, it should be placed in the circumstance of above $15\text{ }^{\circ}\text{C}$ for 3 hours.

[Caution]

When still image is displayed for a period of 20 minutes or longer (Especially where W/B scale is strong. Digital pattern 13ch and/or Cross hatch pattern 09ch), there can some afterimage in the black level area.

3. Automatic Adjustment

3.1. MAC address D/L, CI+ key D/L, Widevine key D/L, ESN D/L, HDCP14/20 D/L, DTCP

Connect: USB port

Communication Prot connection

- Com 1,2,3,4 and 115200(Baudrate)
- Mode check: Online Only
- Check the test process: DETECT → MAC → CI → Widevine → ESN → HDCP14 → HDCP20 → DTCP
- Play: Press Enter key
- Result: Ready, Test, OK or NG
- Printer Out (MAC Address Label)

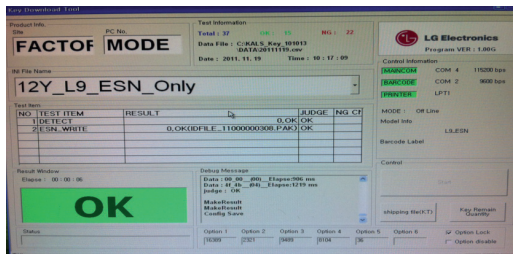

3.2. LAN Inspection

3.2.1. Equipment & Condition

- Each other connection to LAN Port of IP Hub and Jig

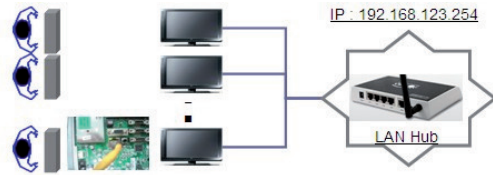

3.2.2. LAN inspection solution

- LAN Port connection with PCB
- Setting automatic IP

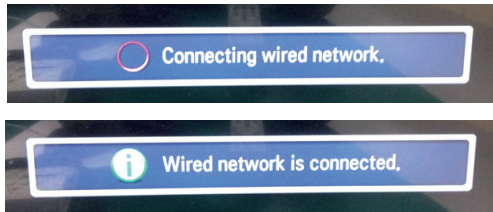

- If you want manual connection, enter Network connection at MENU Mode of TV. Press Start connection key, then Network will be connected.

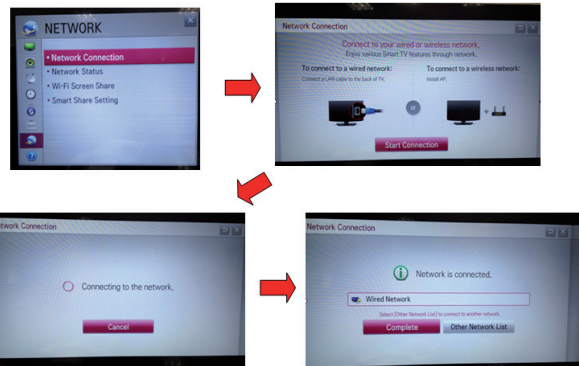

- Setting state confirmation
- If automatic setting is finished, you confirm IP and MAC Address at 'in start' menu mode.

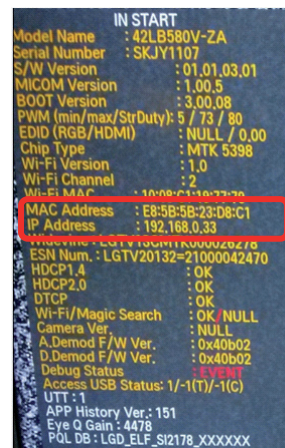

3.2.3. WIDEVINE key Inspection

- Confirm key input data at the "IN START" MENU Mode.

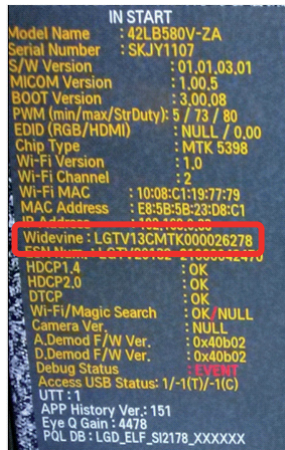

3.2.4. DTCP Inspection

- Confirm Key input Data at the "IN START" MENU Mode
- Below DTCP check on "IN START" MENU is enabled only for Models which "DTCP key" tool option is "ON".
- Only EU suffix models DTCP key option is on. (ex.47LB580V-ZA.AEUWLHX)

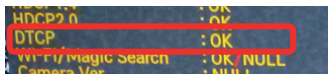

3.3. LAN PORT INSPECTION(PING TEST)

Connect SET → LAN port == PC → LAN Port

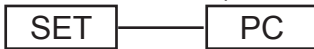

3.3.1. Equipment setting

- (1) Play the LAN Port Test PROGRAM.
- (2) Input IP set up for an inspection to Test Program.
*IP Number : 12.12.2.2

3.3.2. LAN PORT inspection(PING TEST)

- (1) Play the LAN Port Test Program.
- (2) Connect each other LAN Port Jack.
- (3) Play Test (F9) button and confirm OK Message.
- (4) Remove LAN cable.

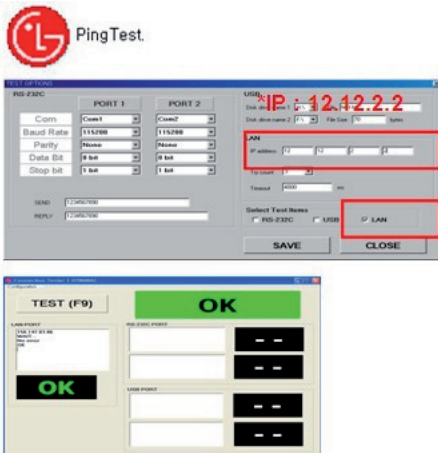

3.4. Model name & Serial number Download

3.4.1. Model name & Serial number D/L

- Press "P-ONLY" key of service remote control. (Baud rate : 115200 bps)
- Connect RS-232C Signal to USB Cable to USB.
- Write Serial number by use USB port.
- Must check the serial number at Instart menu.

3.4.2. Method & notice

- (1) Serial number D/L is using of scan equipment.
- (2) Setting of scan equipment operated by Manufacturing Technology Group.
- (3) Serial number D/L must be conformed when it is produced in production line, because serial number D/L is mandatory by D-book 4.0.

* Manual Download (Model Name and Serial Number)

If the TV set is downloaded by OTA or service man, sometimes model name or serial number is initialized.(Not always)
There is impossible to download by bar code scan, so It need Manual download.

- 1) Press the "Instart" key of Adjustment remote control.
- 2) Go to the menu "7.Model Number D/L" like below photo.
- 3) Input the Factory model name or Serial number like photo.

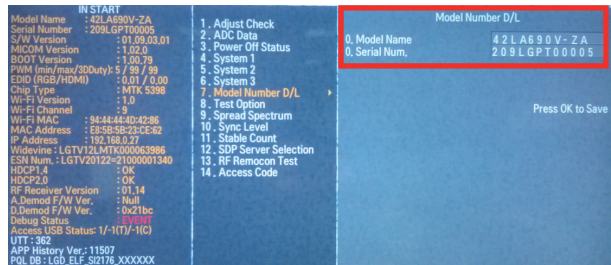

- 4) Check the model name Instart menu. → Factory name displayed. (ex 42LB580V-ZA)
- 5) Check the Diagnostics.(DTV country only) → Buyer model displayed. (ex 42LB580V-ZA)

3.5. CI+ Key checking method

Check whether the key was downloaded or not at 'In Start' menu. (Refer to below).

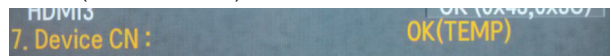

=> Check the Download to CI+ Key value in LGset.

3.5.1. Check the method of CI+ Key value

- (1) Check the method on Instart menu
- (2) Check the method of RS232C Command

1) Into the main ass'y mode(RS232: aa 00 00)

CMD 1	CMD 2	Data 0	Data 1
A	A	0	0

- 2) Check the key download for transmitted command (RS232: ci 00 10)

CMD 1	CMD 2	Data 0	Data 1
C	I	1	0

- 3) Result value
 - Normally status for download : OKx
 - Abnormally status for download : NGx

3.5.2. Check the method of CI+ key value(RS232)

1) Into the main ass'y mode(RS232: aa 00 00)

CMD 1	CMD 2	Data 0	
A	A	0	0

2) Check the method of CI+ key by command (RS232: ci 00 20)

CMD 1	CMD 2	Data 0	
C	I	2	0

3) Result value

i 01 OK 1d1852d21c1ed5dcx
└─┬─> CI+ Key Value

3.6. WIFI MAC ADDRESS CHECK

(1) Using RS232 Command

	H-freq(kHz)	V-freq.(Hz)
Transmission	[A][I][Set ID][20][Cr]	[O][K][X] or [NG]

(2) Check the menu on in-start

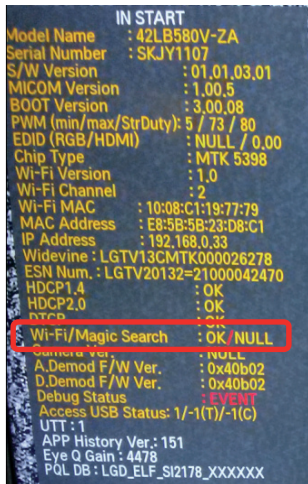

4. Manual Adjustment

* ADC adjustment is not needed because of OTP(Auto ADC adjustment)

4.1. EDID DATA

4.1.1. 2D EDID(FHD)

HDMI EDID DATA 2D																
	0	1	2	3	4	5	6	7	8	9	A	B	C	D	E	F
0	00	FF	01	03	80	A0	5A	78	0A	EE	91	A3	54	4C	99	26
10	0F	50	54	A1	08	00	31	40	45	40	61	40	71	40	81	80
20	01	01	01	01	01	01	02	3A	80	18	71	38	2D	40	58	2C
30	45	00	A0	5A	00	00	00	1E	66	21	50	80	51	00	18	30
40	40	70	36	00	A0	5A	00	00	1E	00	00	00	00	FD	00	3A
50	3E	1E	53	10	00	0A	20	20	20	20	20	20				
60	02	03	29	F1	4E	10	9F	04	13	05	14	03	02	12	01	01
70	22	15	01	29	3D	06	C0	15	07	50	09	57	07		01	21
80	00	00	00	00	00	00	00	00	00	00	00	00	00	00	00	00
90	00	00	00	00	00	00	00	00	00	00	00	00	00	00	00	00
A0	20	58	2C	25	00	A0	5A	00	00	00	9E	01	1D	00	80	51
B0	DD	1A	20	6E	88	55	00	A0	5A	00	00	00	1A	02	3A	80
C0	18	71	38	2D	40	58	2C	45	00	A0	5A	00	00	00	1E	66
D0	21	50	80	51	00	18	30	40	70	36	00	A0	5A	00	00	00
E0	1E	00	00	00	00	00	00	00	00	00	00	00	00	00	00	02

▪ Reference

- HDMI1 ~ HDMI3

- In the data of EDID, bellows may be different by S/W or Input mode.

Ⓐ Product ID

HEX	EDID Table	DDC Function
0001	0100	Analog
0001	0100	Digital

Ⓑ Serial No: Controlled on production line.

Ⓒ Month, Year: Controlled on production line:

ex) Monthly : '01' → '01'

Year : '2014' → '18'

Ⓓ Model Name(Hex): LGTV

Chassis	MODEL NAME(HEX)
LD46S	00 00 00 FC 00 4C 47 20 54 56 0A 20 20 20 20 20 20

Ⓔ Checksum(LG TV): Changeable by total EDID data.

	Ⓔ1	Ⓔ2	Ⓔ3
HDMI1	E7	1B	X
HDMI2	E7	0B	X
HDMI3	E7	FB	X

Ⓕ Vendor Specific(HDMI)

INPUT	MODEL NAME(HEX)
HDMI1	67 03 0C 00 10 00 80 1E
HDMI2	67 03 0C 00 20 00 80 1E
HDMI3	67 03 0C 00 30 00 80 1E

4.1.2. 2D HD EDID(HD)

0	1	2	3	4	5	6	7	8	9	A	B	C	D	E	F	
00	00	FF	FF	FF	FF	FF	00	1E	6D	a			b			
10	c		01	03	80	A0	5A	78	0A	EE	91	A3	54	4C	99	26
20	0F	50	54	A1	08	00	31	40	45	40	61	40	71	40	01	01
30	01	01	01	01	01	01	66	21	50	B0	51	00	1B	30	40	70
40	36	00	40	84	63	00	00	1E	64	19	00	40	41	00	26	30
50	18	88	36	00	40	84	63	00	00	18	00	00	00	FD	00	3A
60	3E	1E	53	10	00	0A	20	20	20	20	20	20	d			
70	d													01	e	
80	02	03	25	F1	4E	10	1F	04	93	05	14	03	02	12	20	21
90	22	15	01	29	3D	06	C0	15	07	50	09	57	07	f		
A0	f					01	1D	80	18	71	1C	16	20	58	2C	25
B0	00	40	84	63	00	00	9E	01	1D	00	BC	52	D0	1E	20	B8
C0	28	55	40	40	84	63	00	00	1E	8C	0A	D0	8A	20	E0	2D
D0	10	10	3E	96	00	40	84	63	00	00	18	02	3A	80	18	71
E0	38	2D	40	58	2C	45	00	40	84	63	00	00	1E	00	00	00
F0	00	00	00	00	00	00	00	00	00	00	00	00	00	00	00	e

- Reference
 - HDMI1 ~ HDMI2
 - In the data of EDID, bellows may be different by S/W or Input mode.

HEX	EDID Table	DDC Function
0001	0100	Analog
0001	0100	Digital

- Ⓐ Product ID
- Ⓑ Serial No: Controlled on production line.
- Ⓒ Month, Year: Controlled on production line:
 - ex) Monthly : '01' → '01'
 - Year : '2014' → '18'
- Ⓓ Model Name(Hex): LGTV

Chassis	MODEL NAME(HEX)
LD33B	00 00 00 FC 00 4C 47 20 54 56 0A 20 20 20 20 20 20

- Ⓔ Checksum(LG TV): Changeable by total EDID data.
- Ⓕ Vendor Specific(HDMI)

INPUT	MODEL NAME(HEX)
HDMI1	67 03 0C 00 10 00 80 1E
HDMI2	67 03 0C 00 20 00 80 1E

4.2. White Balance Adjustment

4.2.1. Overview

- W/B adj. Objective & How-it-works
 - Objective: To reduce each Panel's W/B deviation
 - How-it-works : When R/G/B gain in the OSD is at 192, it means the panel is at its Full Dynamic Range. In order to prevent saturation of Full Dynamic range and data, one of R/G/B is fixed at 192, and the other two is lowered to find the desired value.
 - Adjustment condition : normal temperature
 - Surrounding Temperature : 25 °C ± 5 °C
 - Surrounding Humidity : 20 % ~ 80 %

4.2.2. Equipment

- Color Analyzer: CA-210 (LED Module : CH 14)
 - Adjustment Computer(During auto adj., RS-232C protocol is needed)
 - Adjustment Remote control
 - Video Signal Generator MSPG-925F 720p/216-Gray (Model: 217, Pattern: 49)
 - Only when internal pattern is not available
- Color Analyzer Matrix should be calibrated using CS-1000.

4.2.3. Equipment connection MAP

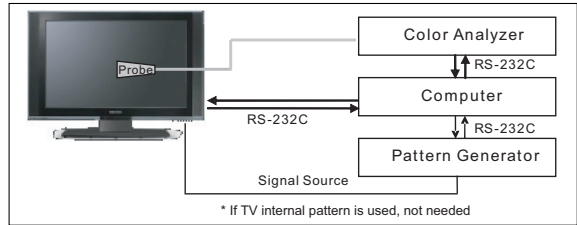

4.2.4. Adj. Command (Protocol)

<Command Format>

START	6E	A	50	A	LEN	A	03	A	CMD	A	00	A	VAL	A	CS	STOP
-------	----	---	----	---	-----	---	----	---	-----	---	----	---	-----	---	----	------

- LEN: Number of Data Byte to be sent
 - CMD: Command
 - VAL: FOS Data value
 - CS: Checksum of sent data
 - A: Acknowledge
- Ex) [Send: JA_00_DD] / [Ack: A_00_okDDX]

- RS-232C Command used during auto-adjustment.

RS-232C COMMAND [CMD ID DATA]	Explanation
wb 00 00	Begin White Balance adjustment
wb 00 10	Gain adjustment(internal white pattern)
wb 00 1f	Gain adjustment completed
wb 00 20	Offset adjustment(internal white pattern)
wb 00 2f	Offset adjustment completed
wb 00 ff	End White Balance adjustment (internal pattern disappears)

- Ex) wb 00 00 -> Begin white balance auto-adj.
 wb 00 10 -> Gain adj.
 ja 00 ff -> Adj. data
 jb 00 c0
 ...
 ...
 wb 00 1f → Gain adj. completed
 *(wb 00 20(Start), wb 00 2f(end)) → Off-set adj.
 wb 00 ff → End white balance auto-adj.

▪ Adj. Map

Applied Model : LD46B Chassis ALL MODELS

	Adj. item	Command (lower caseASCII)		Data Range (Hex.)		Default (Decimal)
		CMD1	CMD2	MIN	MAX	
Cool	R Gain	j	g	00	C0	
	G Gain	j	h	00	C0	
	B Gain	j	i	00	C0	
	R Cut					
	G Cut					
	B Cut					
Medium	R Gain	j	a	00	C0	
	G Gain	j	b	00	C0	
	B Gain	j	c	00	C0	
	R Cut					
	G Cut					
	B Cut					
Warm	R Gain	j	d	00	C0	
	G Gain	j	e	00	C0	
	B Gain	j	f	00	C0	
	R Cut					
	G Cut					
	B Cut					

4.2.5. Adj. method

(1) Auto adj. method

- 1) Set TV in adj. mode using P-Only key.
 - 2) Zero calibrate probe then place it on the center of the display.
 - 3) Connect Cable.(RS-232C to USB)
 - 4) Select mode in adj. Program and begin adj.
 - 5) When adj. is complete (OK Sign), check adj. status pre mode. (Cool, Medium, Warm)
 - 6) Remove probe and RS-232C cable to complete adj.
- W/B Adj. must begin as start command "wb 00 00" , and finish as end command "wb 00 ff", and Adj. offset if need.

All models have to fix G gain(172).

(2) Manual adjustment. method

- 1) Set TV in Adj. mode using P-Only key.
 - 2) Zero Calibrate the probe of Color Analyzer, then place it on the center of LCD module within 10 cm of the surface.
 - 3) Press ADJ key → EZ adjust using adj. R/C → 7. White-Balance then press the cursor to the right(key ►).
(When right key(►) is pressed 204 Gray internal pattern will be displayed)
 - 4) Adjust Cool modes
 - ① Fix the one of R/G/B gain to 192 (default data) and decrease the others.
(If G gain is adjusted over 172 and R and B gain less than 192 , Adjust is O.K.)
 - ② If G gain is less than 172, Increase G gain by up to 172, and then increase R gain and G gain same amount of increasing G gain.
 - ③ If R gain or B gain is over 255, Readjust G gain less than 172, Conform to R gain is 255 or B gain is 255
 - 5) Adjust two modes(Medium / Warm) Fix the one of R/G/B gain to 192(default data) and decrease the others.
 - 6) Adj. is completed, Exit adjust mode using "EXIT" key on Remote control.
- If internal pattern is not available, use RF input. In EZ Adj. menu 6.White Balance, you can select one of 2 Test-pattern: ON, OFF. Default is inner (ON).
By selecting OFF, you can adjust using RF signal in 206 Gray pattern.

* CASE Cool

First adjust the coordinate far away from the target value(x, y).

- 1) x, y > target
 - i) Decrease the R, G.
- 2) x, y < target
 - i) First decrease the B gain,
 - ii) Decrease the one of the others.
- 3) x > target, y < target
 - i) First decrease B, so make y a little more than the target.
 - ii) Adjust x value by decreasing the R.
- 4) x < target, y > target
 - i) First decrease B, so make x a little more than the target.
 - ii) Adjust x value by decreasing the G.

How to adjust

1. If G gain is adjusted over 172 and R gain and B gain less than 192 , Adjust is O.K.
2. If G gain is less than 172 , increase G gain by up to 172, and then increase R gain and B gain same amount of increasing G gain.
3. If R gain or B gain is over 255 , Readjust G gain less than 172, Conform to R gain is 255 or B gain is 255

* CASE Medium / Warm

First adjust the coordinate far away from the target value(x, y).

- 1) x, y > target
 - i) Decrease the R, G.
- 2) x, y < target
 - i) First decrease the B gain,
 - ii) Decrease the one of the others.
- 3) x > target, y < target
 - i) First decrease B, so make y a little more than the target.
 - ii) Adjust x value by decreasing the R
- 4) x < target, y > target
 - i) First decrease B, so make x a little more than the target.
 - ii) Adjust x value by decreasing the G

▪ Adjustment condition and cautionary items

- 1) Lighting condition in surrounding area
Surrounding lighting should be lower 10 lux. Try to isolate adj. area into dark surrounding.
- 2) Probe location
: Color Analyzer(CA-210) probe should be within 10 cm and perpendicular of the module surface (80° ~ 100°)

4.2.6. Reference (White balance Adj. coordinate and color temperature)

- Luminance : 204 Gray
- Standard color coordinate and temperature using CS-1000 (over 26 inch)

Mode	Coordinate		Temp	Δuv
	x	y		
Cool	0.271	0.270	13000 K	0.0000
Medium	0.286	0.289	9300 K	0.0000
Warm	0.313	0.329	6500 K	0.0000

- Standard color coordinate and temperature using CA-210(CH 14)

Mode	Coordinate		Temp	Δuv
	x	y		
Cool	0.271 ± 0.002	0.270 ± 0.002	13000 K	0.0000
Medium	0.286 ± 0.002	0.289 ± 0.002	9300 K	0.0000
Warm	0.313 ± 0.002	0.329 ± 0.002	6500 K	0.0000

4.2.7. LED White balance table

- EDGE LED module change color coordinate because of aging time.
- Apply under the color coordinate table, for compensated aging time.

- * Only March to December & Global

Model : (normal line) LB49/57/58_LGD/CMI

NC4.5	Aging time (Min)	Cool		Medium		Warm	
		x	y	x	y	x	y
		271	270	286	289	313	329
1	0-2	281	287	295	310	320	342
2	3-5	280	285	294	308	319	340
3	6-9	278	284	292	307	317	339
4	10-19	276	281	290	304	315	336
5	20-35	275	277	289	300	314	332
6	36-49	274	274	288	297	313	329
7	50-79	273	272	287	295	312	327
8	80-119	272	271	286	294	311	326
9	Over 120	271	270	285	293	310	325

- * Only for the table for January & February

Model : (normal line) LB49/57/58_LGD/CMI

NC4.5	Aging time (Min)	Cool		Medium		Warm	
		x	y	x	y	x	y
		271	270	286	289	313	329
1	0-2	283	292	297	315	322	347
2	3-5	282	290	296	313	321	345
3	6-9	280	288	294	311	319	343
4	10-19	277	284	291	307	316	339
5	20-35	275	279	289	302	314	334
6	36-49	274	275	288	298	313	330
7	50-79	273	272	287	295	312	327
8	80-119	272	271	286	294	311	326
9	Over 120	271	270	285	293	310	325

Model : (aging chamber) LB49/57/58_LGD/CMI

NC4.5	Aging time (Min)	Cool		Medium		Warm	
		x	y	x	y	x	y
		271	270	286	289	313	329
1	0-5	280	285	294	308	319	340
2	6-10	276	280	290	303	315	335
3	11-20	272	275	286	298	311	330
4	21-30	269	272	283	295	308	327
5	31-40	267	268	281	291	306	323
6	41-50	266	265	280	288	305	320
7	51-80	265	263	279	286	304	318
8	81-119	264	261	278	284	303	316
9	Over 120	264	260	278	283	303	315

- * AUO, INX, Sharp, CSOT(In case of Cool speck is 13000 K)

	Cool		med		warm	
	x	y	x	y	x	y
spec	271	270	286	289	313	329
target	275	276	289	299	317	335
Luminance (cd/m ²)	Min	Typ	Min	Typ	Min	Typ
	80	110	80	110	80	110

4.3. Magic Remote control test

- Results are automatically marked in Instart OSD after through the AP/Magic Remote control Equipment on the line

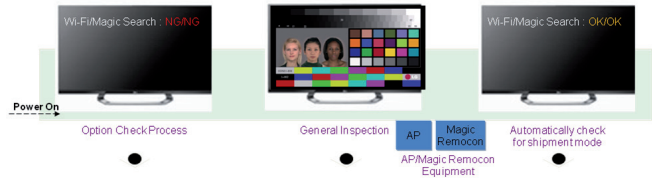

4.4. Wi-Fi Test

- 1) Turn on TV
- 2) Select Network Connection option in Network Menu.

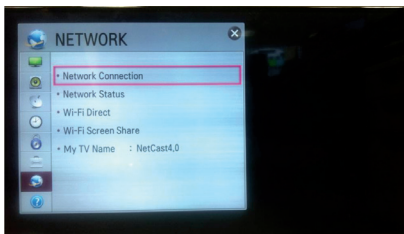

- 3) Select Start Connection button in Network Connection.

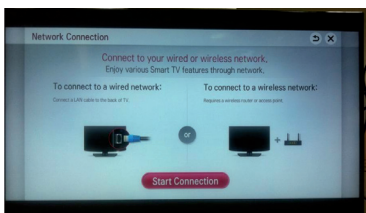

- 4) If the system finds any AP like blow PIC, it is working well.

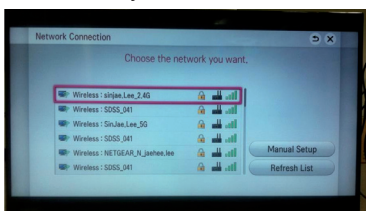

4.5. LNB voltage and 22KHz tone check

(only for DVB-S/S2 model)

• Test method

- (1) Set TV in Adj. mode using POWER ON.
- (2) Connect cable between satellite ANT and test JIG.
- (3) Press Yellow key(ETC+SWAP) in Adj Remote control to make LNB on.
- (4) Check LED light 'ON' at 18 V menu.
- (5) Check LED light 'ON' at 22 KHz tone menu.
- (6) Press Blue key(ETC+PIP INPUT) in Adj Remote control to make LNB off.
- (7) Check LED light 'OFF' at 18 V menu.
- (8) Check LED light 'OFF' at 22 KHz tone menu.

• Test result

- (1) After press LNB On key, '18 V LED' and '22 KHz tone LED' should be ON.
- (2) After press LNB OFF key, '18 V LED' and '22 KHz tone LED' should be OFF.

4.6. Option selection per country

4.6.1. Overview

- Option selection is only done for models in Non-EU

4.6.2. Method

- (1) Press ADJ key on the Adj. R/C, then select Country Group Meun.
- (2) Select Country Group Code 04 or Country Group EU

5. Tool Option selection

- Method : Press "ADJ" key on the Adjustment remote control, then select Tool option.

6. Ship-out mode check(In-stop)

- After final inspection, press "IN-STOP" key of the Adjustment remote control and check that the unit goes to Stand-by mode.

7. GND and Internal Pressure check

7.1. Method

- (1) GND & Internal Pressure auto-check preparation
 - Check that Power cord is fully inserted to the SET. (If loose, re-insert)
- (2) Perform GND & Internal Pressure auto-check
 - Unit fully inserted Power cord, Antenna cable and A/V arrive to the auto-check process.
 - Connect D-terminal to AV JACK TESTER
 - Auto CONTROLLER(GWS103-4) ON
 - Perform GND TEST
 - If NG, Buzzer will sound to inform the operator.
 - If OK, changeover to I/P check automatically. (Remove CORD, A/V form AV JACK BOX.)
 - Perform I/P test
 - If NG, Buzzer will sound to inform the operator.
 - If OK, Good lamp will lit up and the stopper will allow the pallet to move on to next process.

7.2. Checkpoint

- TEST voltage
 - (1) DQA Test
 - GND: AC 1.5 KV/min, Cut off current not exceed 100 mA
 - SIGNAL: AC 3.0 KV/min, Cut off current not exceed 100 mA
 - (2) Mass Production Line Test
 - GND: AC 1.5 KV/sec, Cut off current not exceed 100 mA
- TEST time: DQA 1 min, Mass Production Line 1 sec
- TEST POINT
 - GND TEST = POWER CORD GND & SIGNAL CABLE METAL GND
 - Internal Pressure TEST = POWER CORD GND & LIVE & NEUTRAL
- LEAKAGE CURRENT: At 0.5 mArms

8. Audio

No.	Item	Min	Typ	Max	Unit	Remark
1.	Audio practical max Output, L/R(Distortion=10% max Output)	9	10	12	W	EQ Off AVL Off Clear Voice Off
			8.10	10.8	Vrms	
2.	Speaker(8 Ω Impedance)	9	10	12	W	

Measurement condition:

- (1) RF input: Mono, 1 KHz sine wave signal, 100 % Modulation
- (2) CVBS, Component: 1 KHz sine wave signal 0.5 Vrms

9. USB S/W Download(Service only)

- (1) Put the USB Stick to the USB socket
- (2) Automatically detecting update file in USB Stick
 - If your downloaded program version in USB Stick is Lower, it didn't work.
 - But your downloaded version is Higher, USB data is automatically detecting (Download Version High & Power only mode, Set is automatically Download)
- (3) Show the message "Do not unplug!".

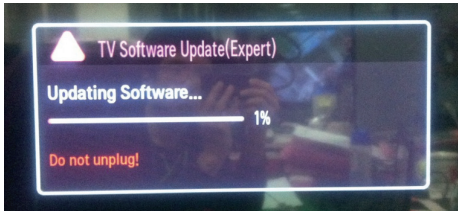

- (4) Updating is starting.

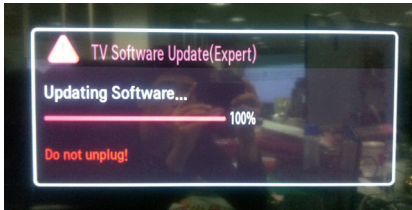
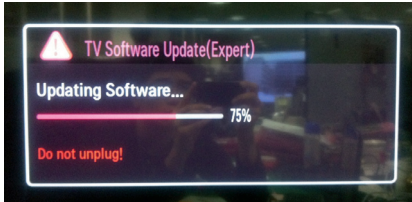

- (5) Updating completed, the TV will restart automatically.
- (6) If your TV is turned on, check your updated version and Tool option. (explain the Tool option, next stage)
 - * If downloading version is more high than your TV have, TV can lost all channel data. In this case, you have to channel recover. if all channel data is cleared, you didn't have a DTV/ATV test on production line.

* After downloading, have to adjust Tool Option again.

- (1) Push "IN-START" key in service remote control.
- (2) Select "Tool Option 1" and push "OK" key.
- (3) Punch in the number. (Each model has their number)

BLOCK DIAGRAM

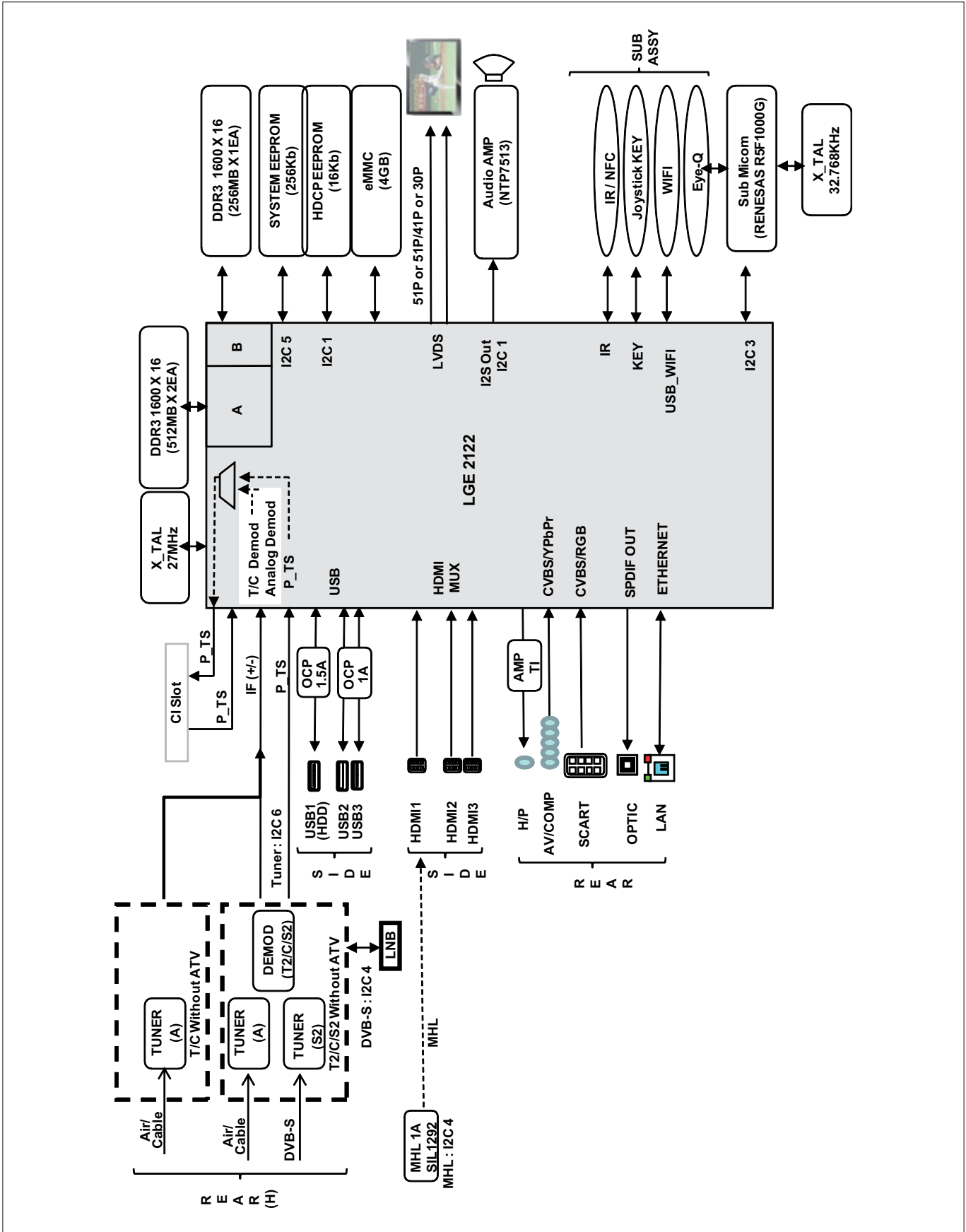

EXPLODED VIEW

IMPORTANT SAFETY NOTICE

Many electrical and mechanical parts in this chassis have special safety-related characteristics. These parts are identified by Δ in the Schematic Diagram and EXPLODED VIEW. It is essential that these special safety parts should be replaced with the same components as recommended in this manual to prevent X-RADIATION, Shock, Fire, or other Hazards. Do not modify the original design without permission of manufacturer.

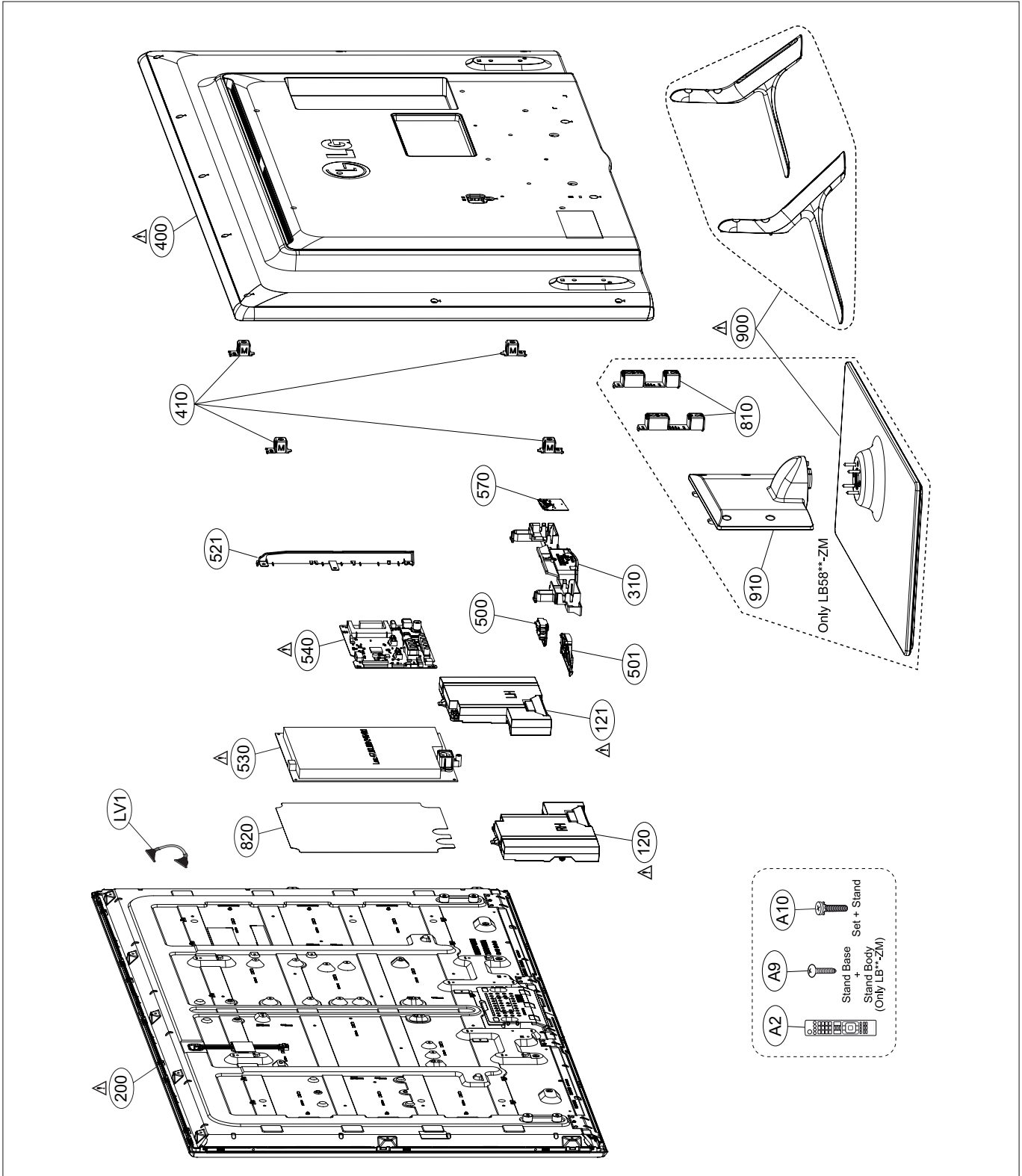

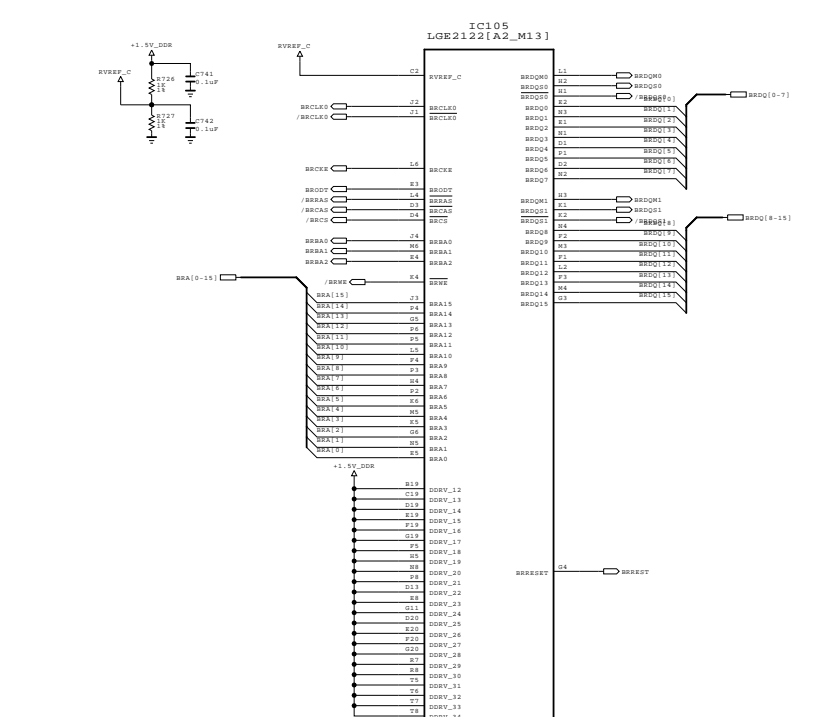
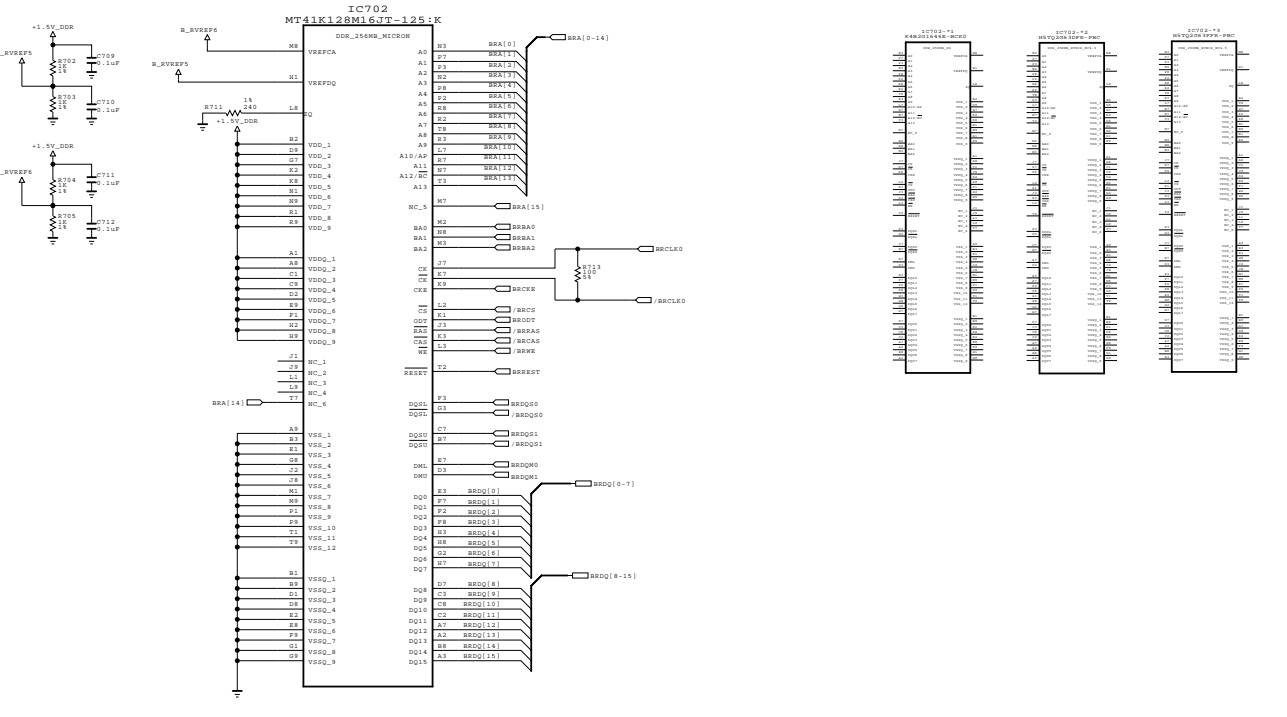
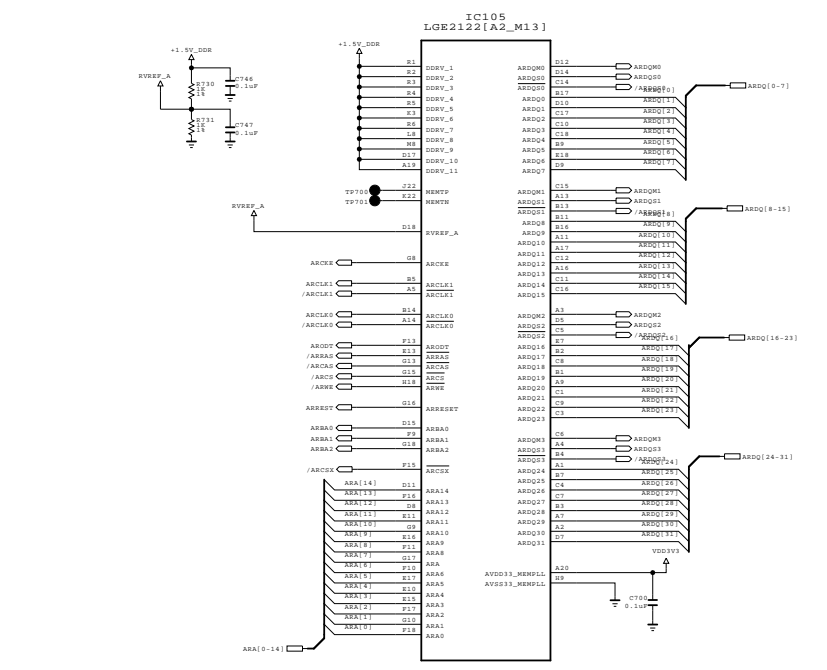
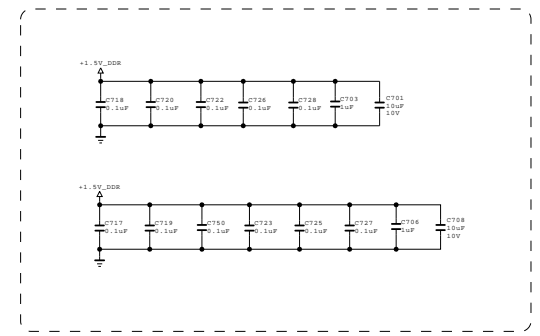
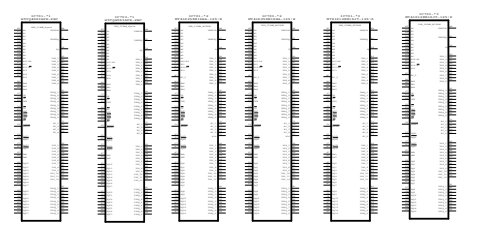
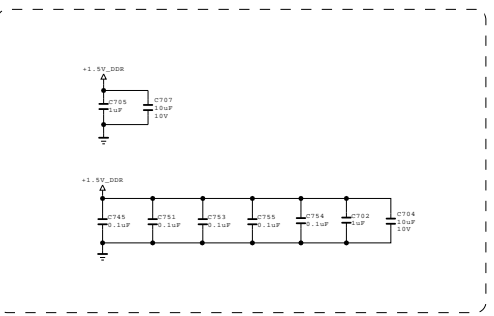
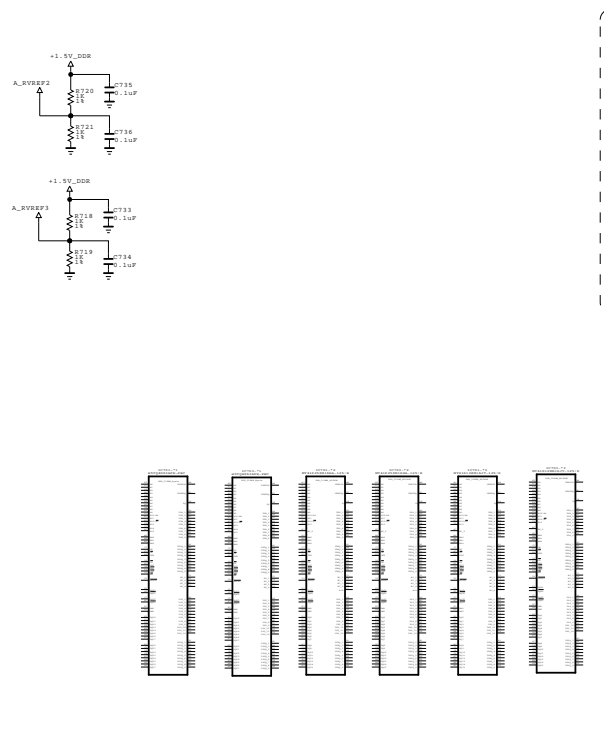
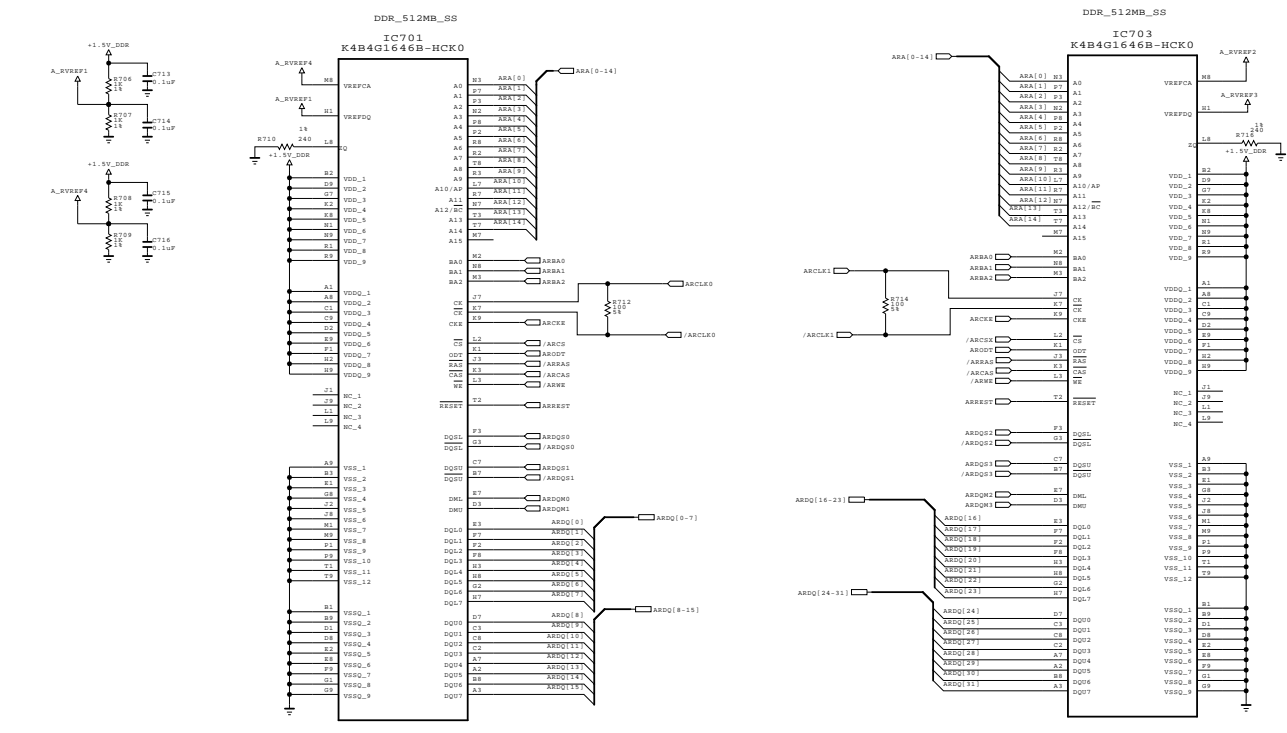

THE SYMBOL MARK OF THIS SCHEMATIC DIAGRAM INCORPORATES SPECIAL FEATURES IMPORTANT FOR PROTECTION FROM X-RADIATION. FIRE AND ELECTRICAL SHOCK HAZARDS, WHEN SERVICING IF IS ESSENTIAL THAT ONLY MANUFACTURERS SPECIFIED PARTS BE USED FOR THE CRITICAL COMPONENTS IN THE SYMBOL MARK OF THE SCHEMATIC.

SECRET
LGElectronics

LG ELECTRONICS

MODEL	DDR ONE SIDE	DATE	2011.12.09
BLOCK		SHEET	12

SPDIF

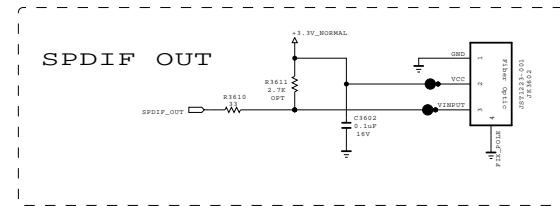

THE SYMBOL MARK OF THIS SCHEMATIC DIAGRAM INCORPORATES SPECIAL FEATURES IMPORTANT FOR PROTECTION FROM X-RADIATION. FIRE AND ELECTRICAL SHOCK HAZARDS, WHEN SERVICING IF IS ESSENTIAL THAT ONLY MANUFACTURERS SPECIFIED PARTS BE USED FOR THE CRITICAL COMPONENTS IN THE SYMBOL MARK OF THE SCHEMATIC.

SECRET
LGElectronics

LG ELECTRONICS

MODEL	JACK HIGH / MID	DATE	2011.11.21
BLOCK		SHEET	36 /

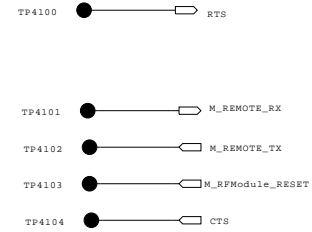
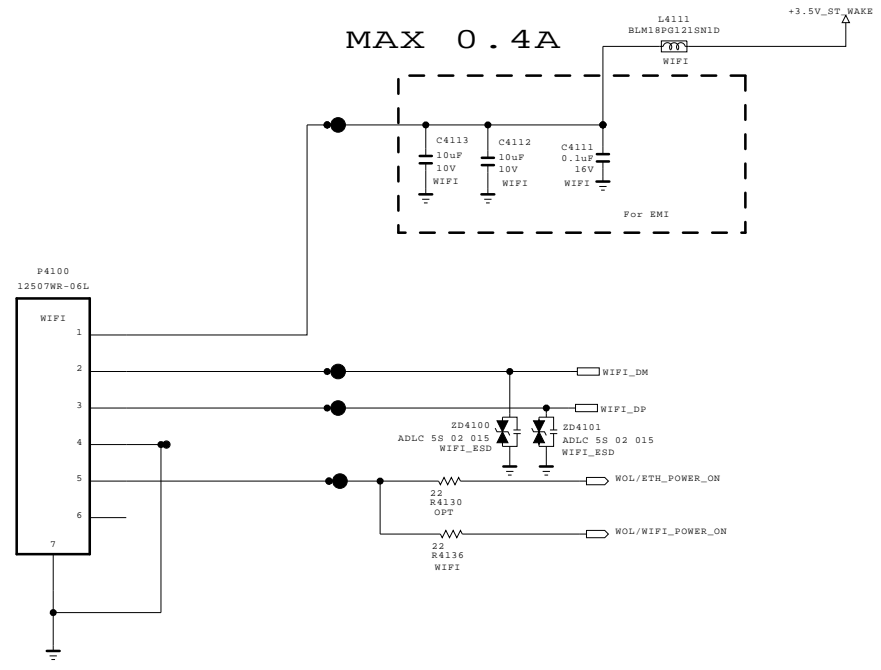
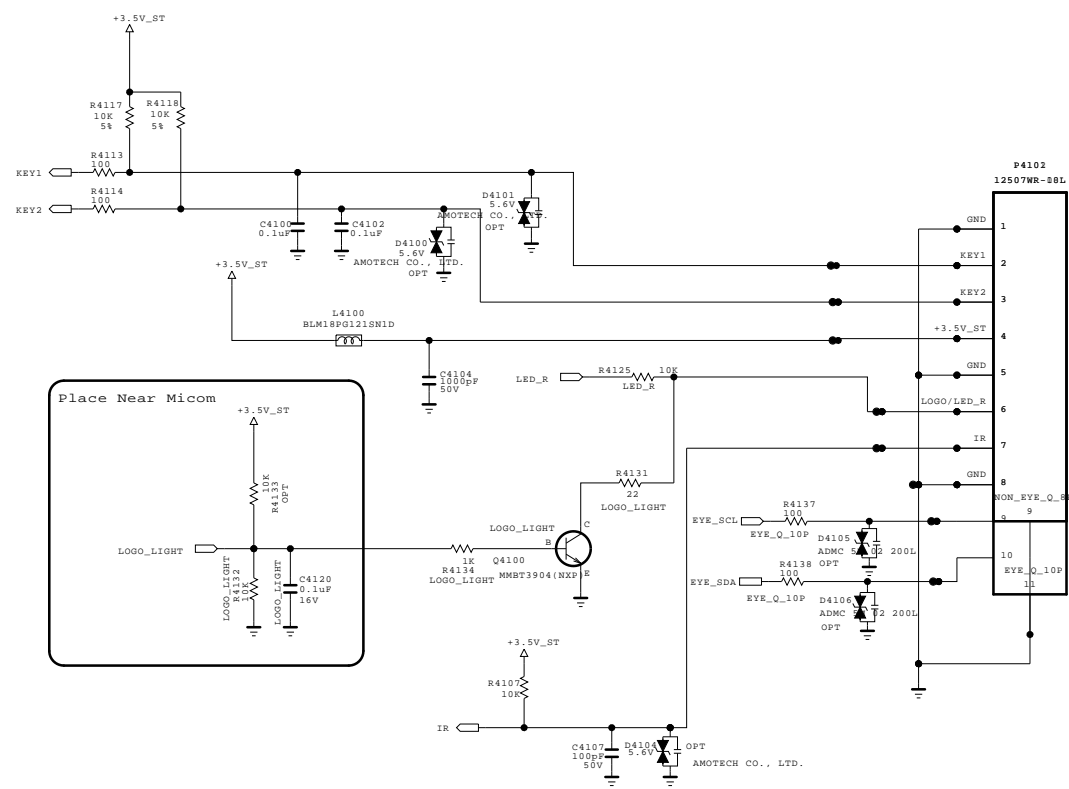

THE SYMBOL MARK OF THIS SCHEMATIC DIAGRAM INCORPORATES SPECIAL FEATURES IMPORTANT FOR PROTECTION FROM X-RADIATION. FIRE AND ELECTRICAL SHOCK HAZARDS, WHEN SERVICING IF IS ESSENTIAL THAT ONLY MANUFACTURERS SPECIFIED PARTS BE USED FOR THE CRITICAL COMPONENTS IN THE SYMBOL MARK OF THE SCHEMATIC.

SECRET
LGElectronics



MODEL	IR / KEY	DATE	2011.11.21
BLOCK		SHEET	41 /

DEBUG FOR INTERNAL AMOD.

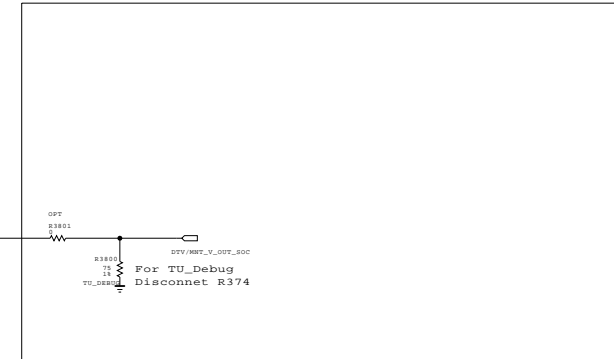

UART FOR DEBUG

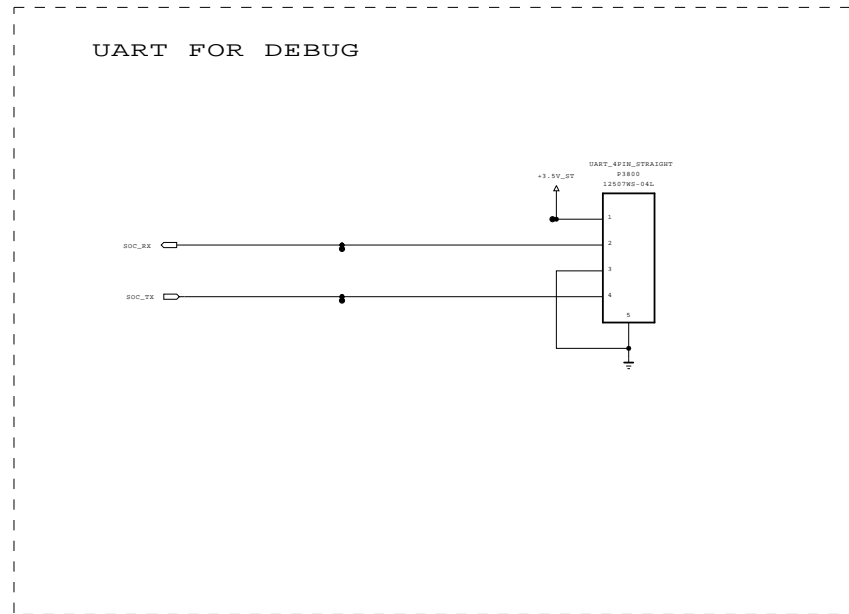

AV/COMPONENT REAR

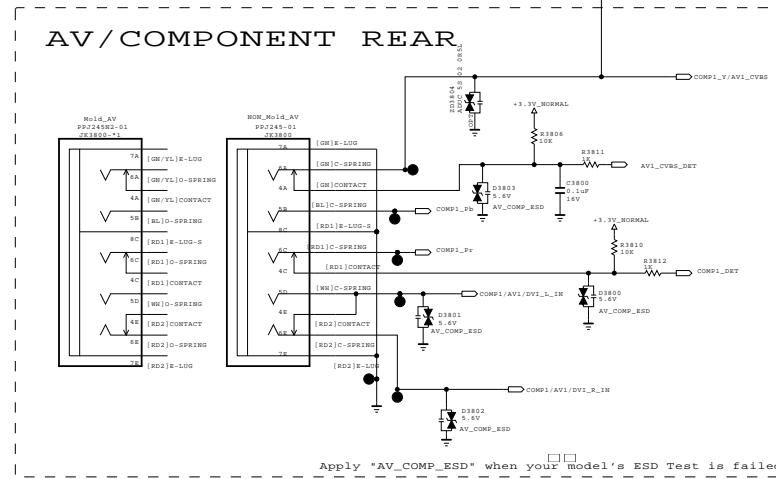

THE SYMBOL MARK OF THIS SCHEMATIC DIAGRAM INCORPORATES SPECIAL FEATURES IMPORTANT FOR PROTECTION FROM X-RADIATION. FIRE AND ELECTRICAL SHOCK HAZARDS, WHEN SERVICING IF IS ESSENTIAL THAT ONLY MANUFACTURERS SPECIFIED PARTS BE USED FOR THE CRITICAL COMPONENTS IN THE SYMBOL MARK OF THE SCHEMATIC.

SECRET
LGElectronics

LG ELECTRONICS

MODEL	JACK_COMMON	DATE	2011.11.21
BLOCK		SHEET	38 /

DUAL COMPONENT	
Q1801	1ST : OTRIY80001A 2ND : OTR387500AA

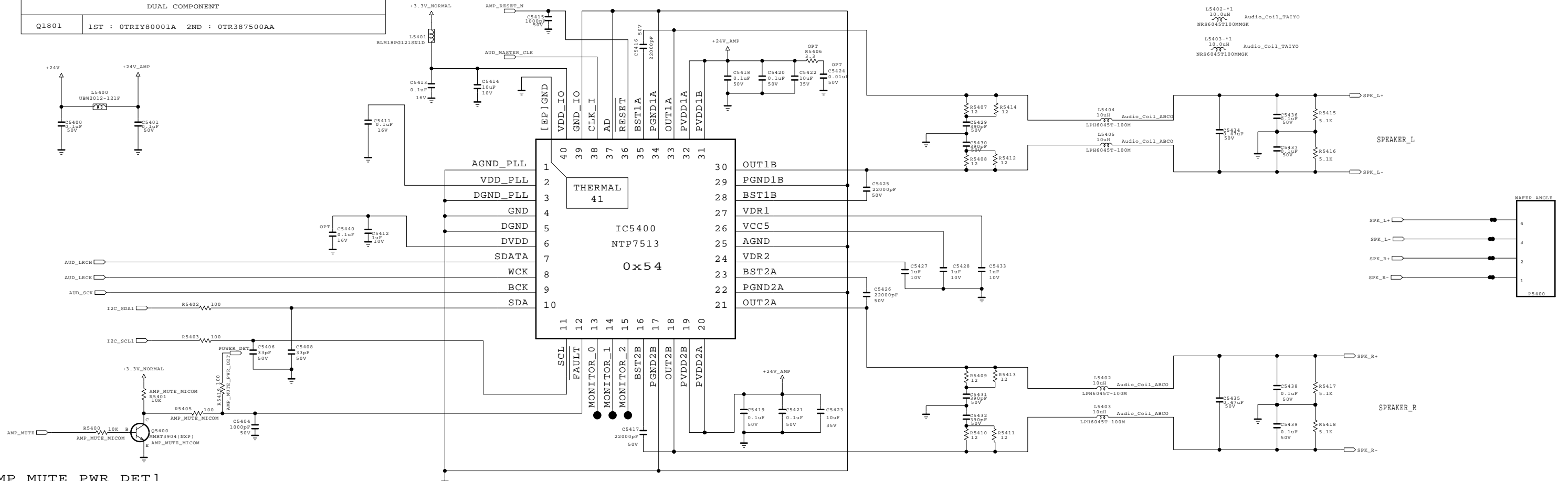

[AMP_MUTE_PWR_DET]
 -->For fixing AC-OFF POP noise 32"POLA/ROW model
 -->32"POLA/ROW LPB's 3.5st drop time is very fast

THE SYMBOL MARK OF THIS SCHEMATIC DIAGRAM INCORPORATES SPECIAL FEATURES IMPORTANT FOR PROTECTION FROM X-RADIATION. FIRE AND ELECTRICAL SHOCK HAZARDS, WHEN SERVICING IF IS ESSENTIAL THAT ONLY MANUFACTURERS SPECIFIED PARTS BE USED FOR THE CRITICAL COMPONENTS IN THE SYMBOL MARK OF THE SCHEMATIC.



SECRET
 LGElectronics

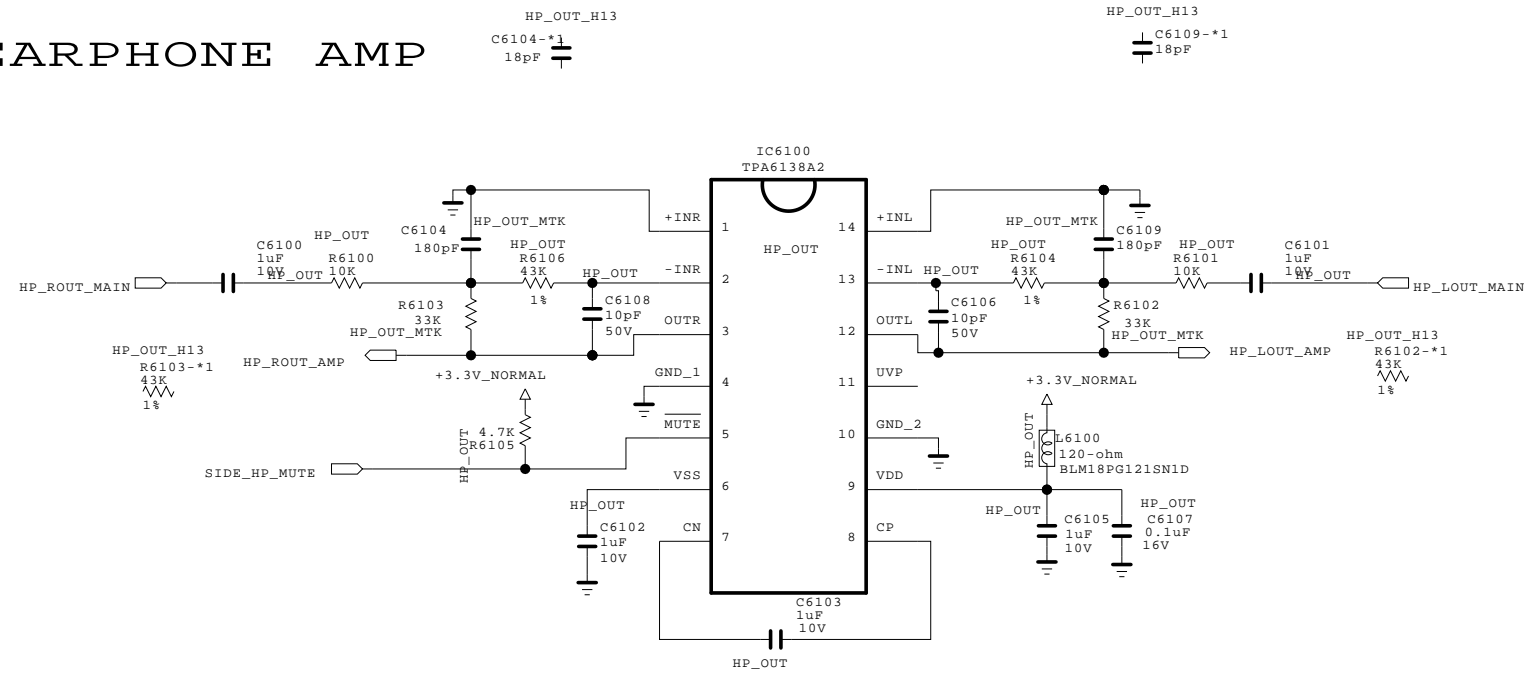

MODEL	AMP_NEO	DATE	2011.11.21
BLOCK		SHEET	54 /

EARPHONE AMP



THE  SYMBOL MARK OF THIS SCHEMATIC DIAGRAM INCORPORATES SPECIAL FEATURES IMPORTANT FOR PROTECTION FROM X-RADIATION. FIRE AND ELECTRICAL SHOCK HAZARDS, WHEN SERVICING IF IS ESSENTIAL THAT ONLY MANUFACTURERS SPECIFIED PARTS BE USED FOR THE CRITICAL COMPONENTS IN THE  SYMBOL MARK OF THE SCHEMATIC.

SECRET
LGElectronics

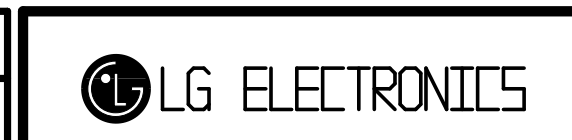



MODEL	HEADPHONE AMP	DATE	2011.09.29
BLOCK		SHEET	61 /

LOCAL DIMMING

[To LED DRIVER]

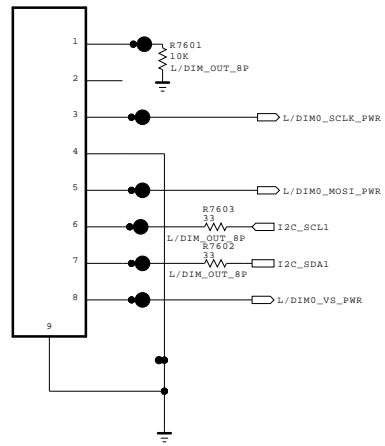
P7600
12507MS-08L
L/DIM_OUT_SP



THE  SYMBOL MARK OF THIS SCHEMATIC DIAGRAM INCORPORATES SPECIAL FEATURES IMPORTANT FOR PROTECTION FROM X-RADIATION. FIRE AND ELECTRICAL SHOCK HAZARDS, WHEN SERVICING IF IS ESSENTIAL THAT ONLY MANUFACTURERS SPECIFIED PARTS BE USED FOR THE CRITICAL COMPONENTS IN THE  SYMBOL MARK OF THE SCHEMATIC.

SECRET
LGElectronics



MODEL	LOCAL DIMMING	DATE	2011.12.13
BLOCK		SHEET	76 /

eMMC I/F

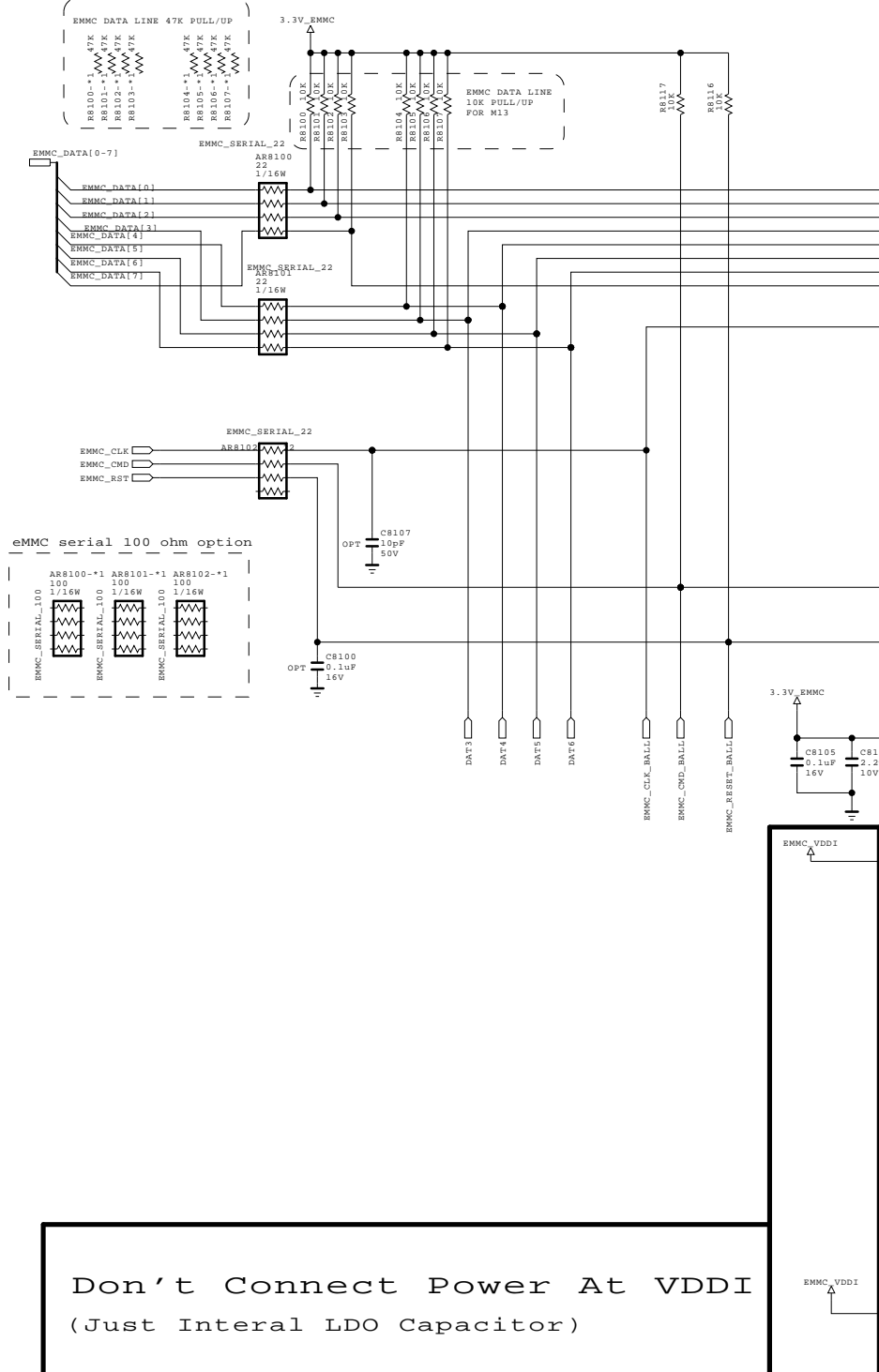

Don't Connect Power At VDD1
(Just Internal LDO Capacitor)

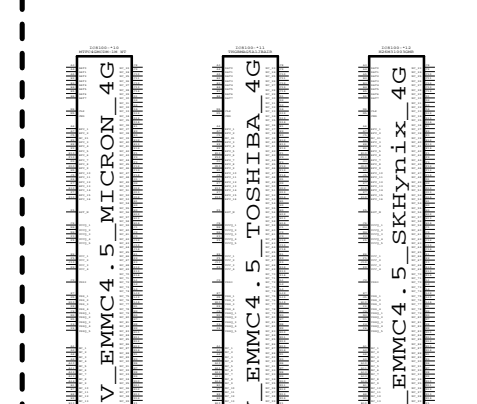
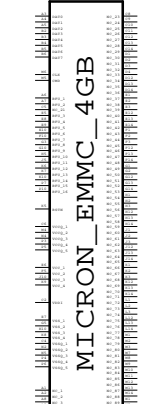
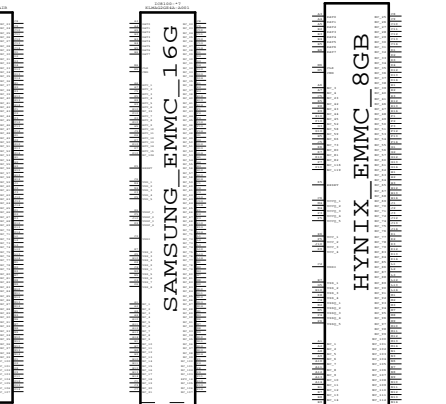
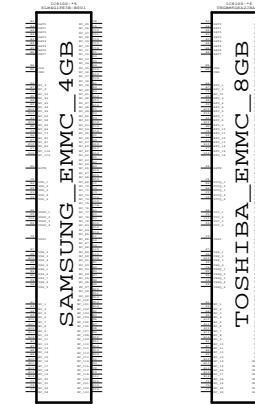
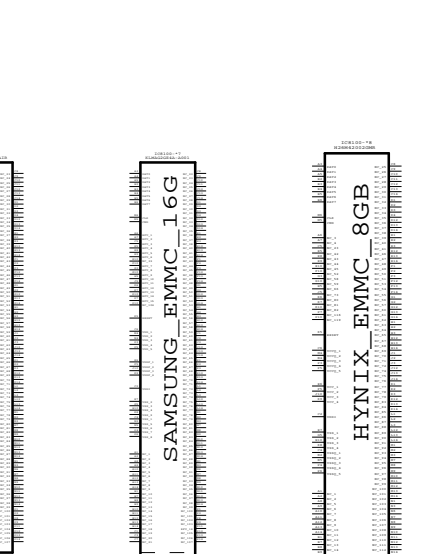
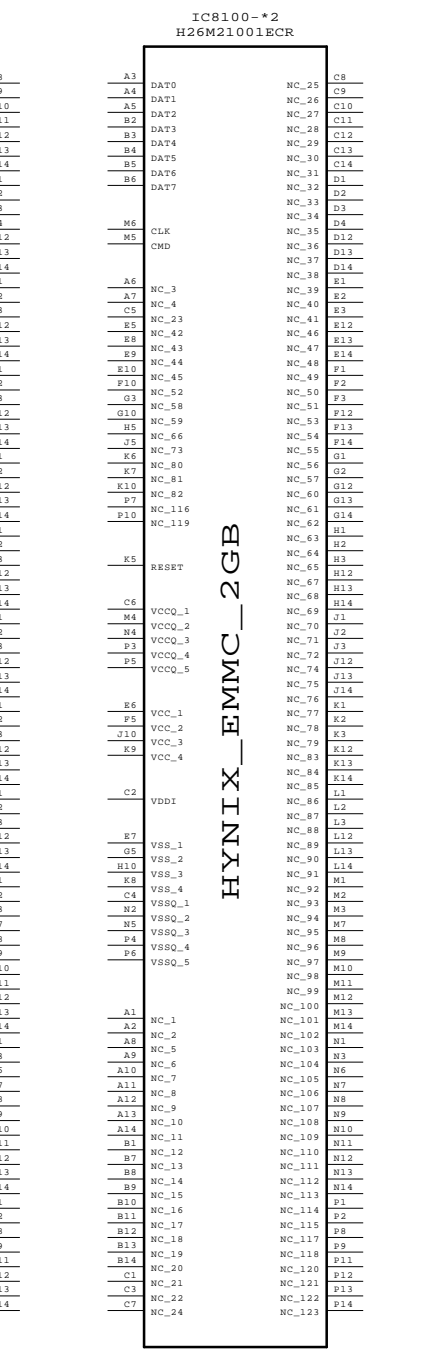
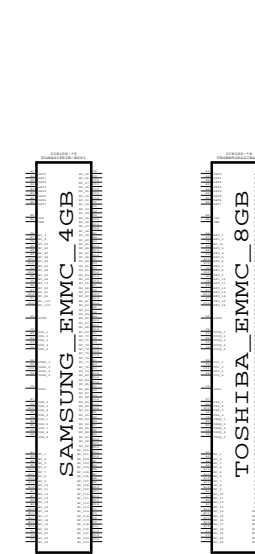
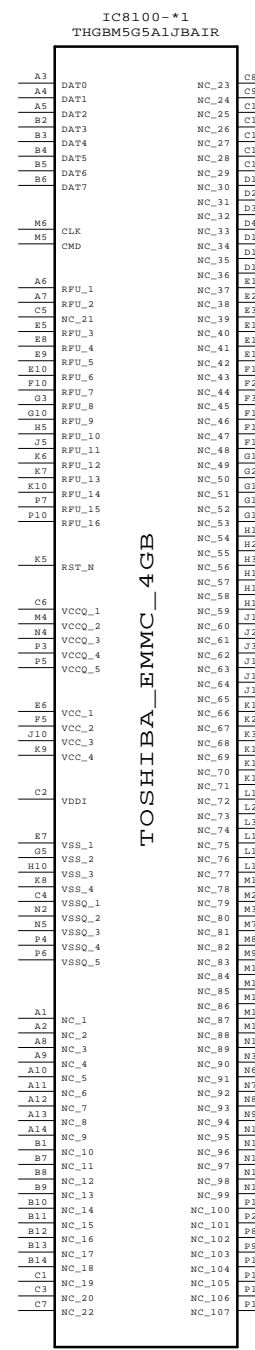
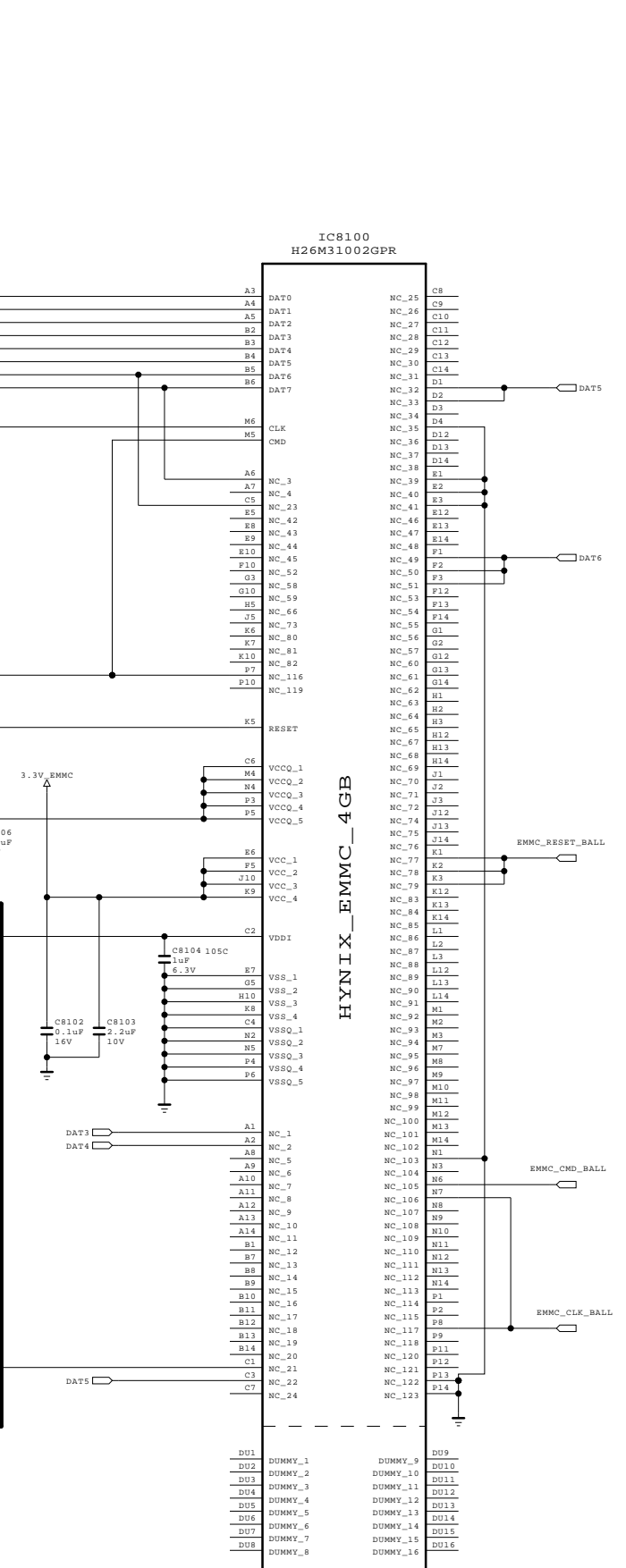



THE Δ SYMBOL MARK OF THIS SCHEMATIC DIAGRAM INCORPORATES SPECIAL FEATURES IMPORTANT FOR PROTECTION FROM X-RADIATION. FIRE AND ELECTRICAL SHOCK HAZARDS, WHEN SERVICING IF IS ESSENTIAL THAT ONLY MANUFACTURERS SPECIFIED PARTS BE USED FOR THE CRITICAL COMPONENTS IN THE Δ SYMBOL MARK OF THE SCHEMATIC.

SECRET
LGElectronics

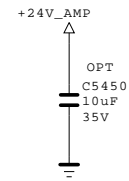

MODEL	eMMC	DATE	11.09.29
BLOCK		SHEET	81



THE  SYMBOL MARK OF THIS SCHEMATIC DIAGRAM INCORPORATES SPECIAL FEATURES IMPORTANT FOR PROTECTION FROM X-RADIATION. FIRE AND ELECTRICAL SHOCK HAZARDS, WHEN SERVICING IT IS ESSENTIAL THAT ONLY MANUFACTURERS SPECIFIED PARTS BE USED FOR THE CRITICAL COMPONENTS IN THE  SYMBOL MARK OF THE SCHEMATIC.

SECRET
LGElectronics

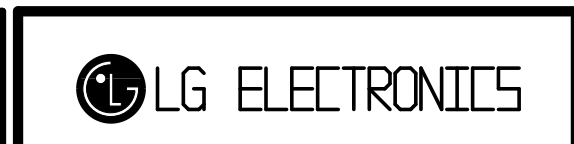

MODEL		DATE	
BLOCK		SHEET	/

M13 EAX64872104 BASE
14y Smart TV

M13 PCB P/NO
EAX64797001* : LD33B
EAX64872101* : LA33B

NC4.5 PCB P/NO
NON CI : EAX65610201
CI :

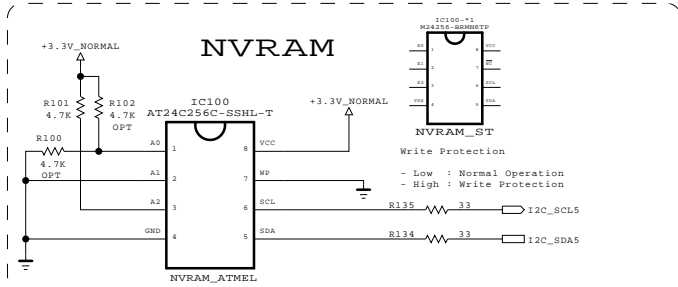

HDCP EEPROM

Deleted

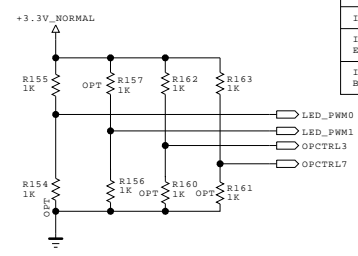

STRAPPING	LED_PWM0	LED_PWM1	OPCTRL3	OPCTRL7
ICE mode + 27M + serial boot	1	0	0	0
ICE mode + 27M + ROM to NAND boot	1	0	0	1
ICE mode + 27M + ROM to 60bit ECC NAND boot	1	0	1	0
ICE mode + 27M + ROM to eMMC boot from eMMC pins (share pins w/ NAND)	1	0	1	1
ICE mode + 27M + ROM to eMMC Boot from SDIO pins	1	1	0	0

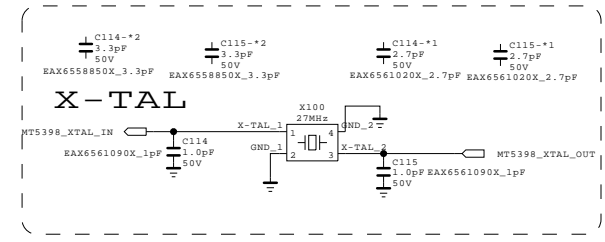
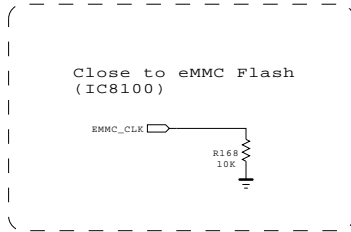

M13 vs Lean Smart
del. FE_LNA_Ctrl1/2
cause of Tuner change 13y to 14y

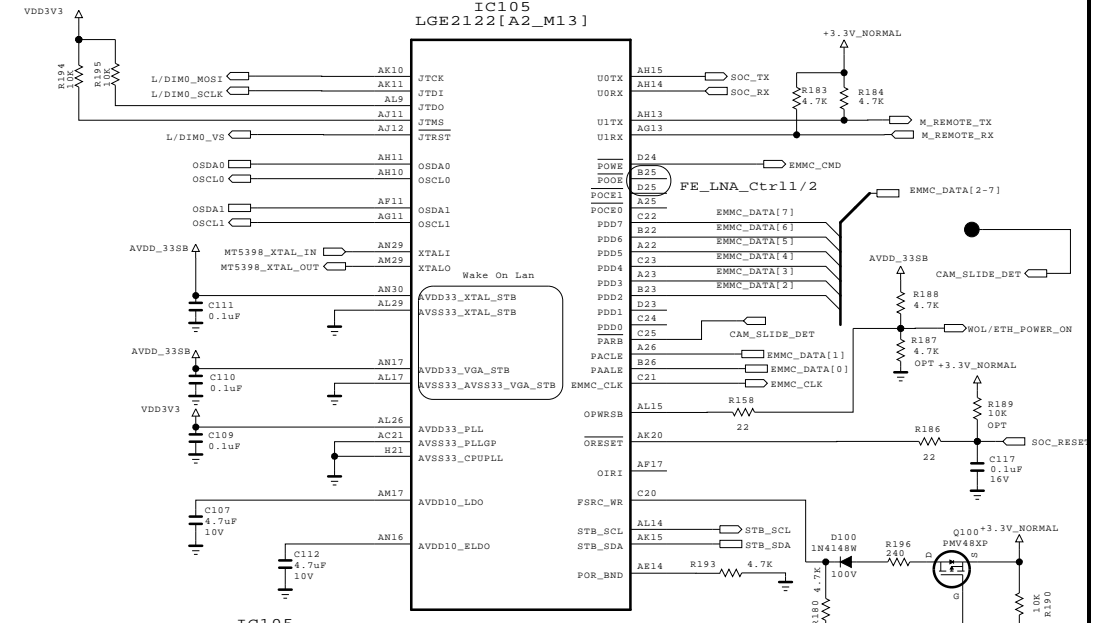

I2C

I2C_1 : AMP, L/DIMMING, HDCP KEY
I2C_2 : T-CON,
I2C_3 : MCOM
I2C_4 : S/Demod, T2/Demod, LNB, MHL(S11292)
I2C_5 : NVRAM
I2C_6 : TUNER_MOPLL(T/C, ATV)

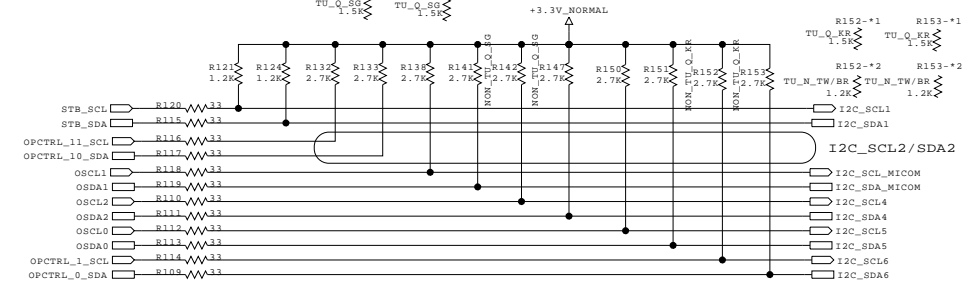

M13 vs Lean Smart
del. I2C_SCL2/SDA2
cause of EPI block deletion

Model Option

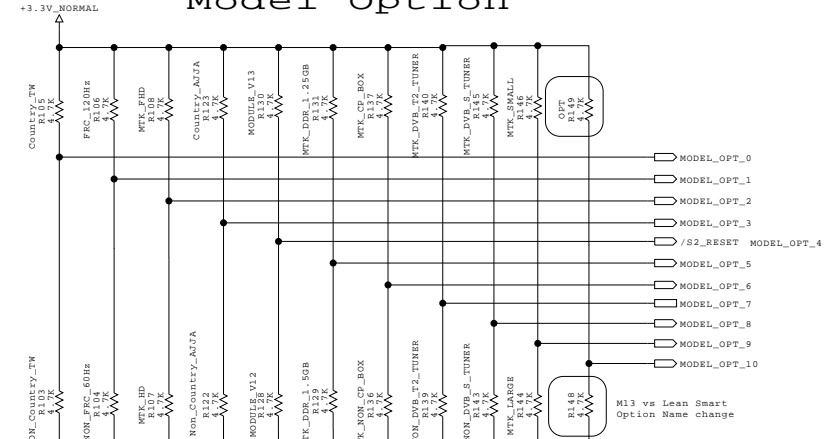

MODEL_OPT	Country_TW	TW	Non_TW
MODEL_OPT_0	Country_TW	TW	Non_TW
MODEL_OPT_1	FRC	FRC(120Hz) No FRC(60Hz)	
MODEL_OPT_2	Panel	FHD	HD
MODEL_OPT_3	Country_AJJA	AJJA	Non_AJJA
MODEL_OPT_4	Module	V13	V12
MODEL_OPT_5	DDR	DDR_1.25G	DDR_1.5G
MODEL_OPT_6	CP BOX	Enable	Disable
MODEL_OPT_7	T2 Tuner	Support	Not Support
MODEL_OPT_8	S Tuner	Support	Not Support
MODEL_OPT_9	DDR	DDR_0.78G	NON_DDR_0.78G
MODEL_OPT_10	EPI	OPT	Default

M13 vs Lean Smart
Option Name change
Support to Opt
Not Support to Deault

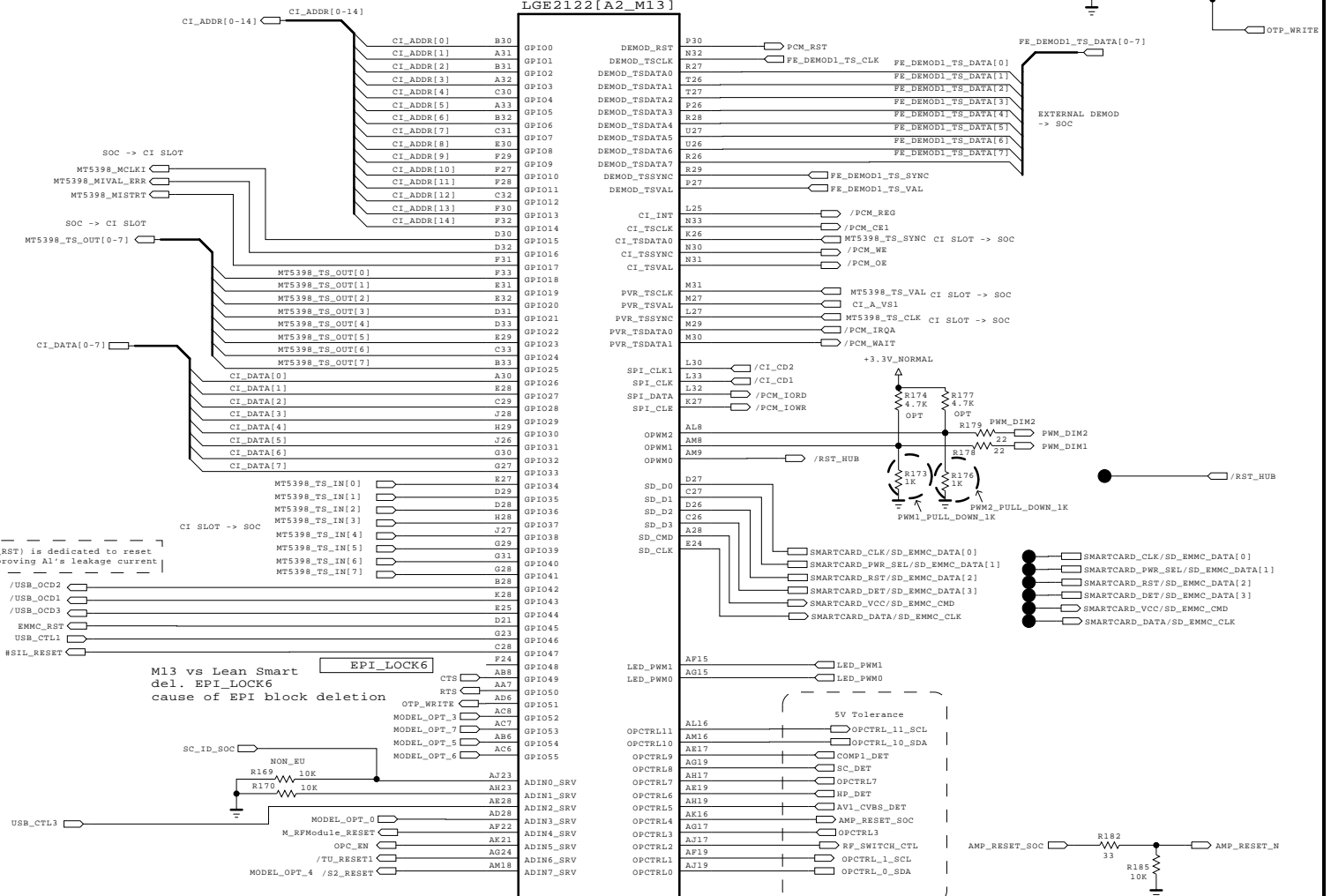

M13 vs Lean Smart
del. EPI_LOCK6
cause of EPI block deletion

THE Δ SYMBOL MARK OF THIS SCHEMATIC DIAGRAM INCORPORATES SPECIAL FEATURES IMPORTANT FOR PROTECTION FROM X-RADIATION, FIRE AND ELECTRICAL SHOCK HAZARDS, WHEN SERVICING IF IS ESSENTIAL THAT ONLY MANUFACTURES SPECIFIED PARTS BE USED FOR THE CRITICAL COMPONENTS IN THE Δ SYMBOL MARK OF THE SCHEMATIC.

SECRET
LGElectronics



MODEL	MID_MAIN_1	DATE	2013.07.16
BLOCK		SHEET	508

PLACE AT JACK SIDE

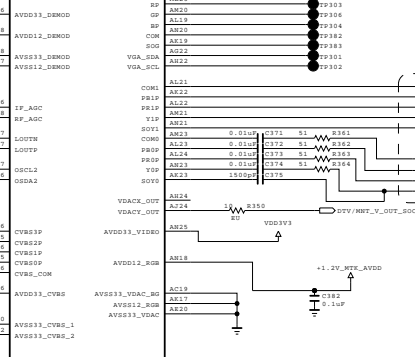
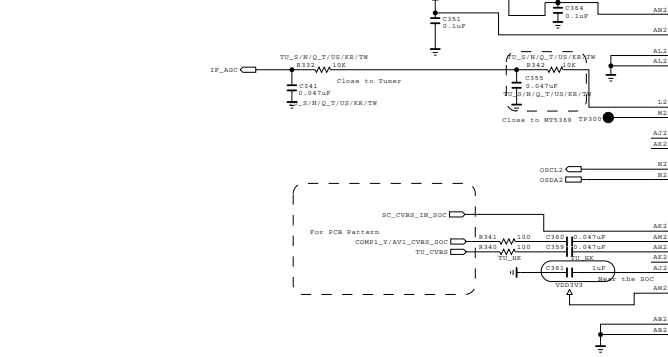
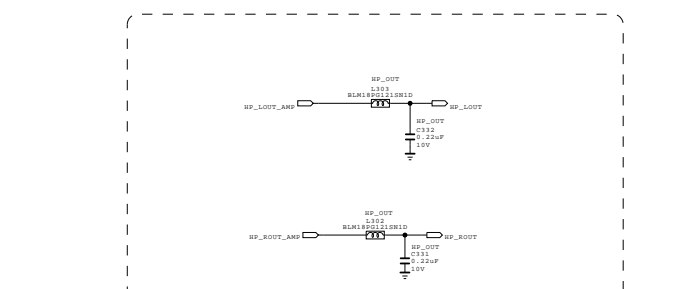
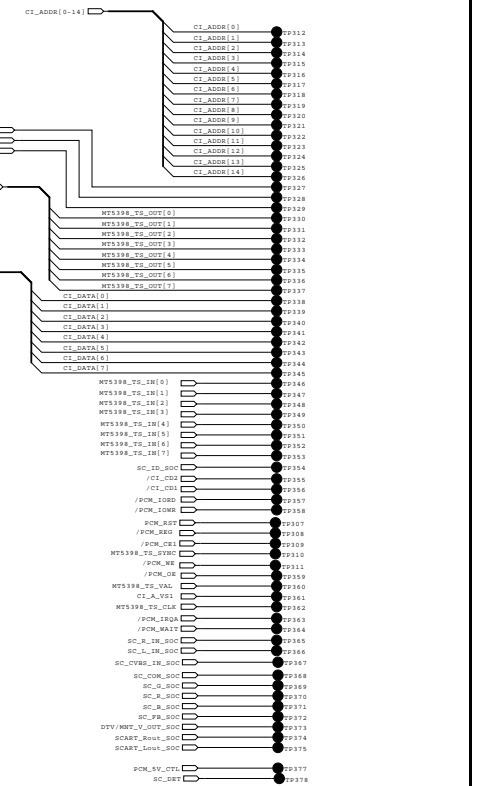
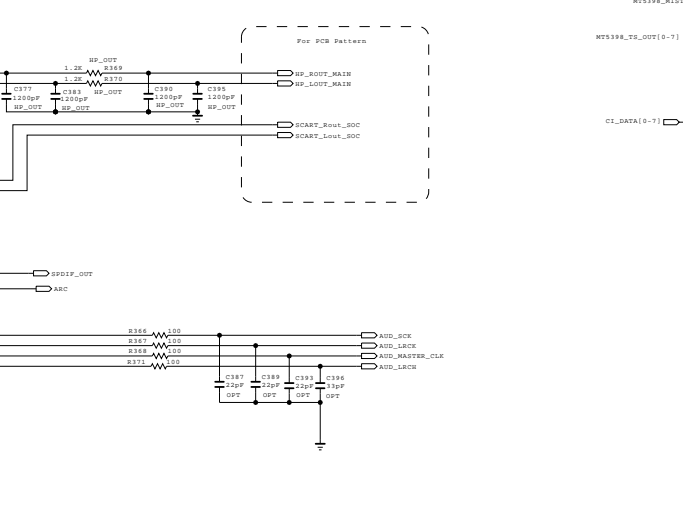
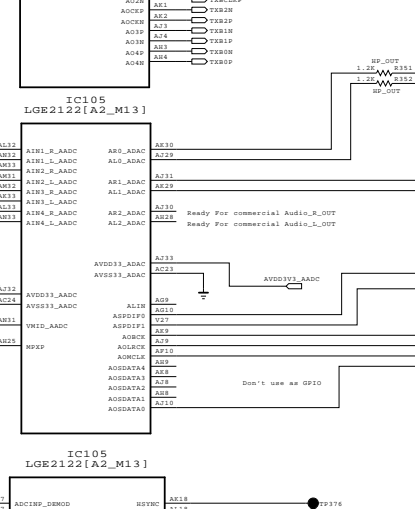
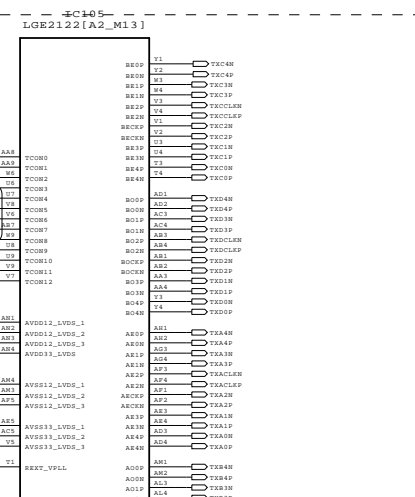
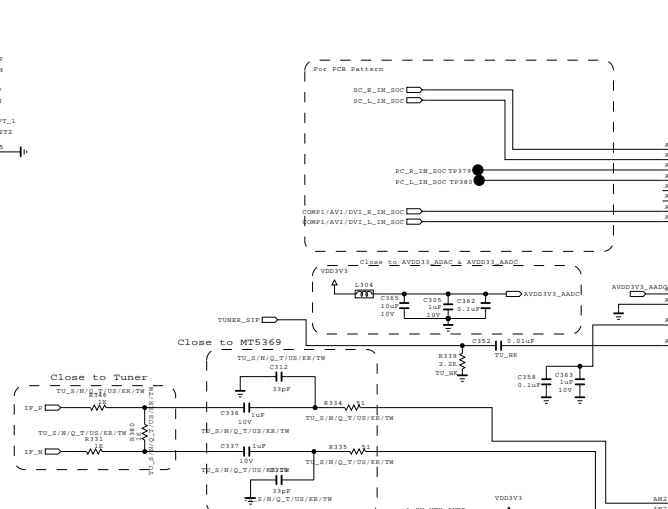
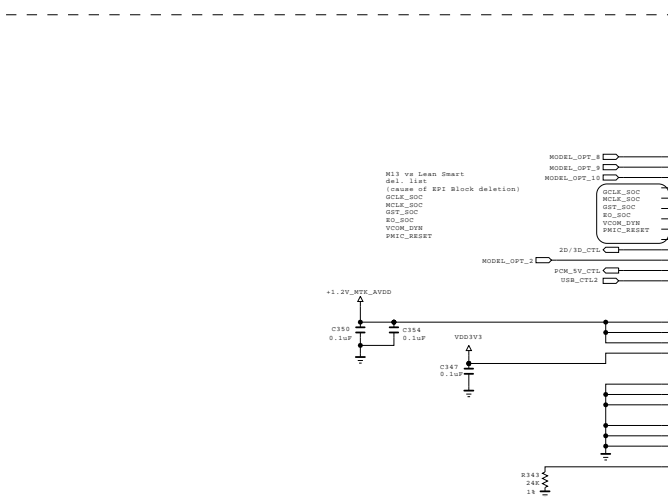
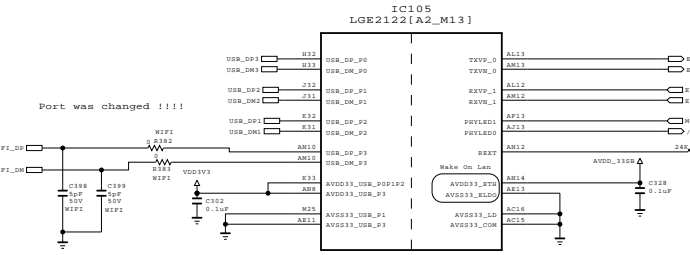
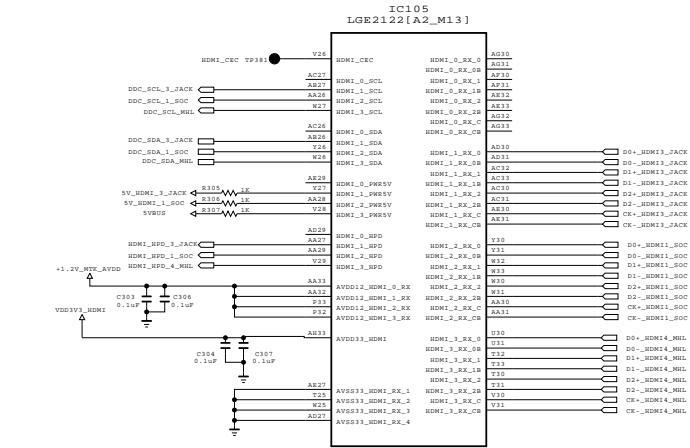
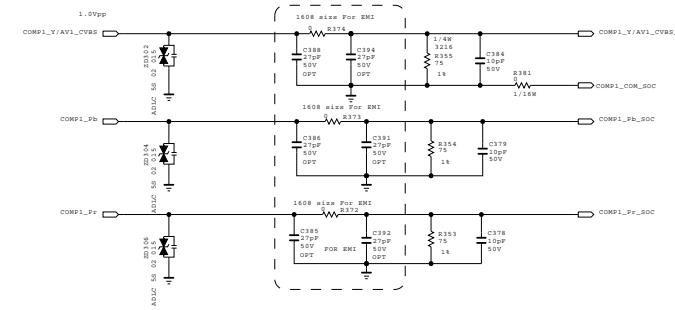
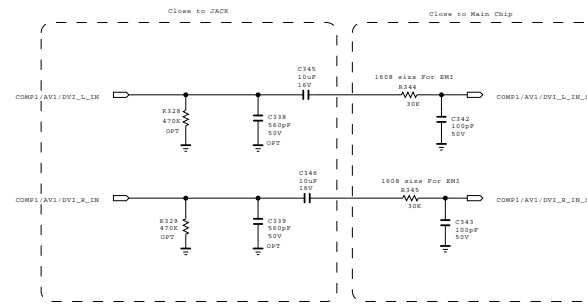
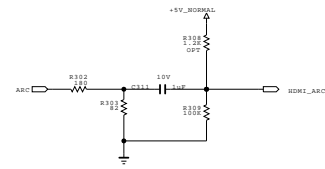

Place at JACK SIDE

THE SYMBOL MARK OF THIS SCHEMATIC DIAGRAM INCORPORATES SPECIAL FEATURES IMPORTANT FOR PROTECTION FROM X-RADIATION. FIRE AND ELECTRICAL SHOCK HAZARDS, WHEN SERVICING IF IS ESSENTIAL THAT ONLY MANUFACTURERS SPECIFIED PARTS BE USED FOR THE CRITICAL COMPONENTS IN THE SYMBOL MARK OF THE SCHEMATIC.

SECRET
LGElectronics

LG ELECTRONICS

MODEL	MID_MAIN_2	DATE	2013.07.16
BLOCK		SHEET	509

FROM LPB & PSU

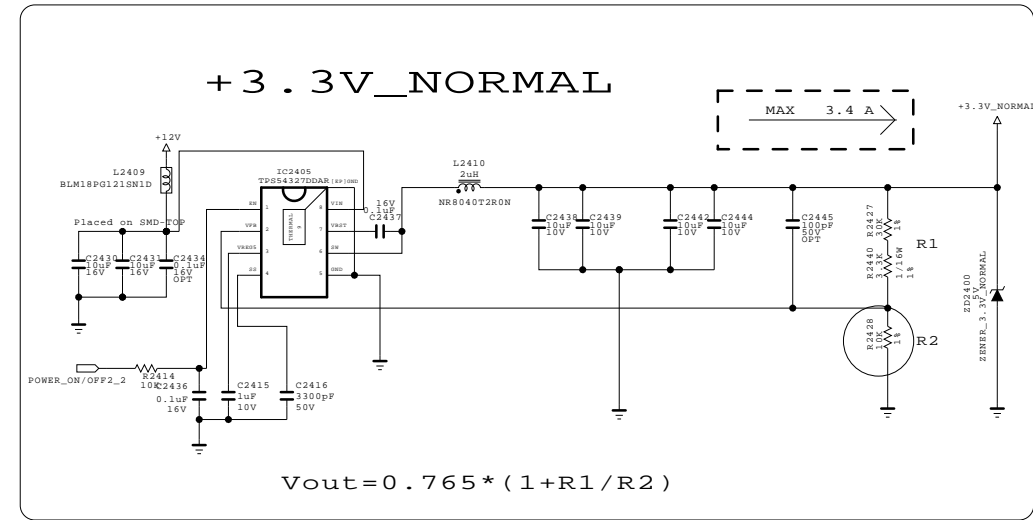
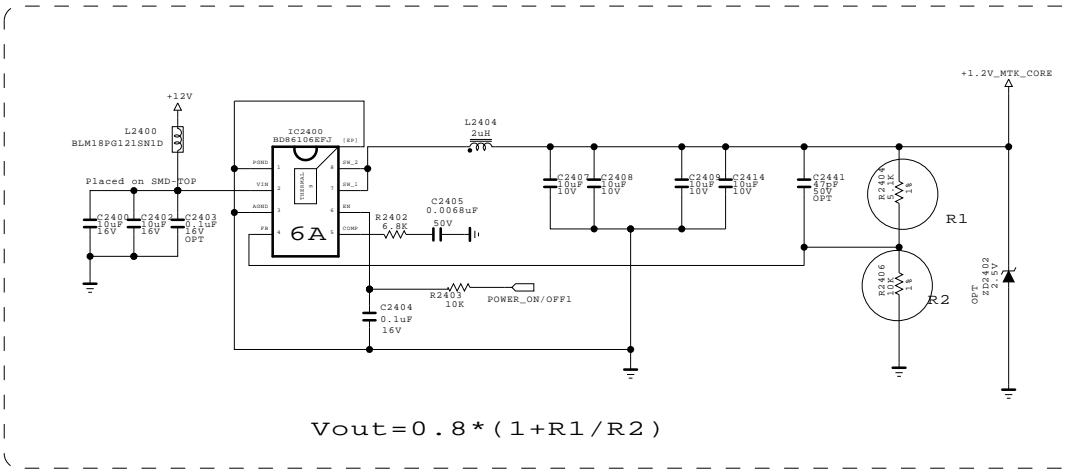
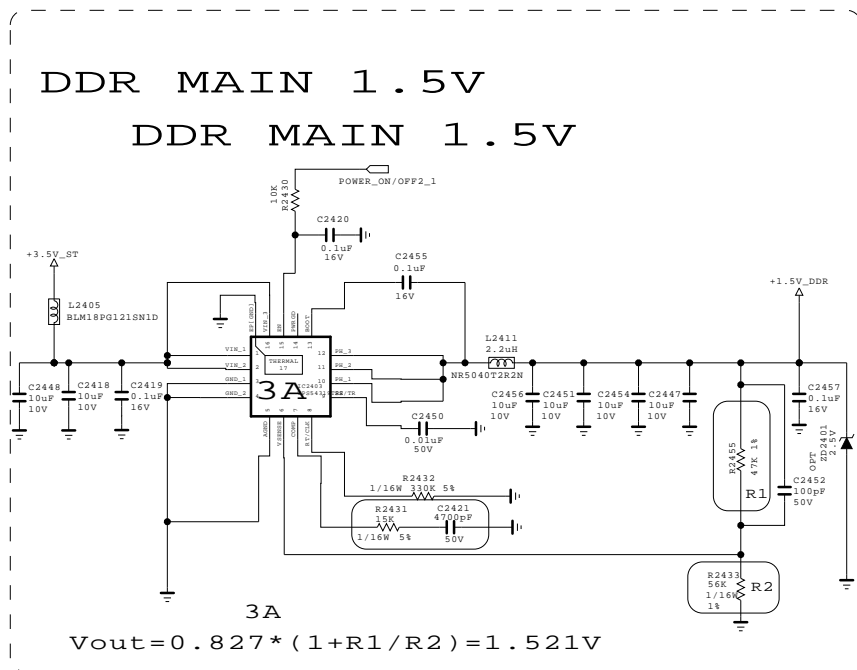
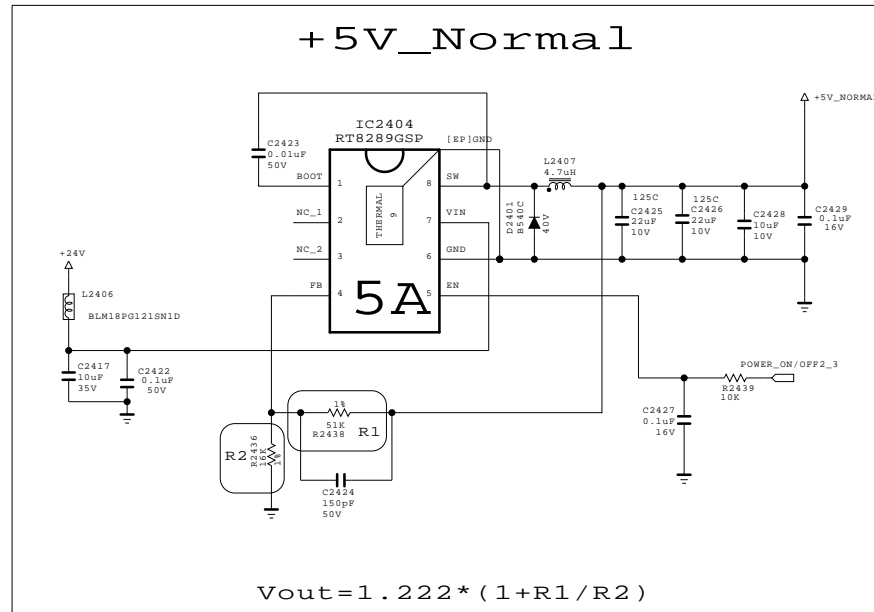
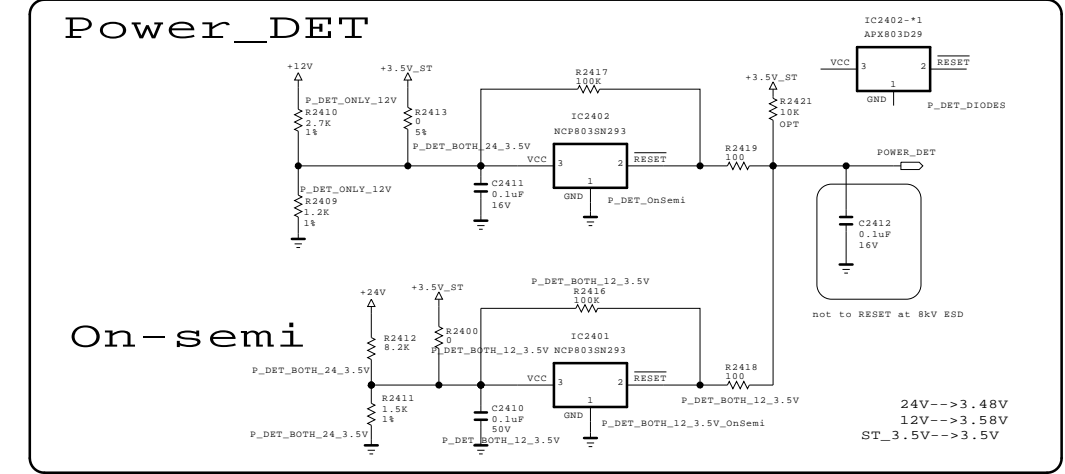
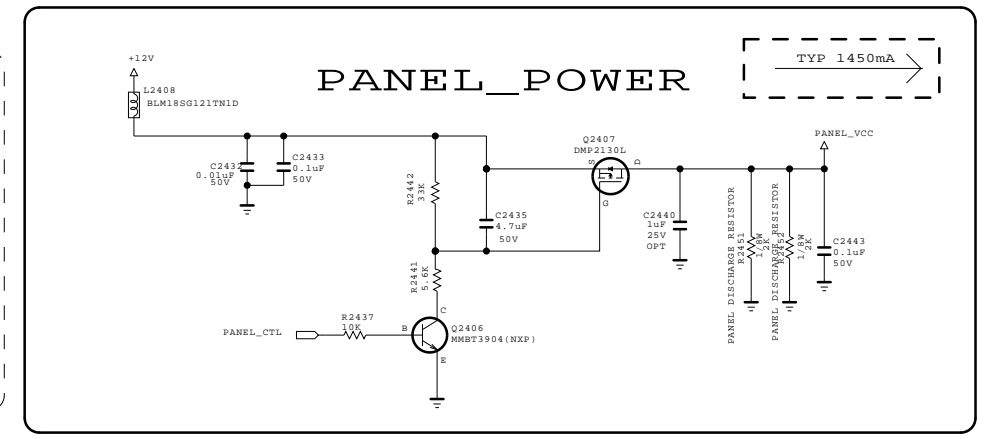
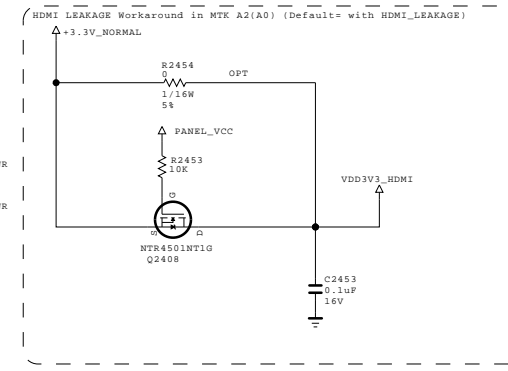
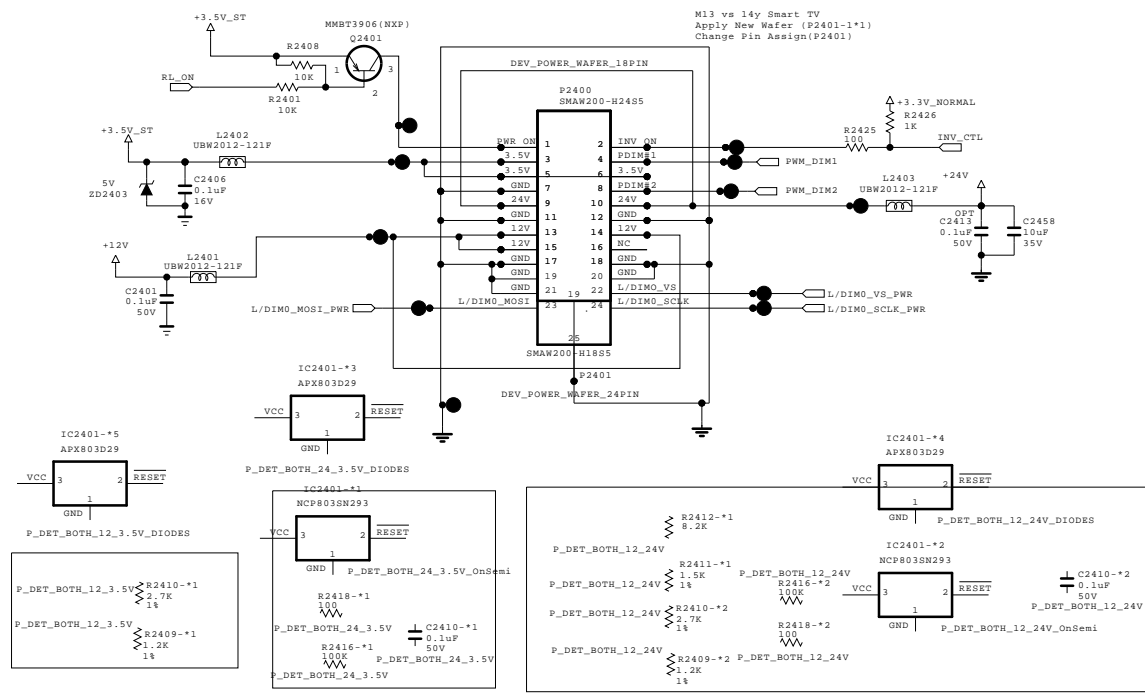

THE Δ SYMBOL MARK OF THIS SCHEMATIC DIAGRAM INCORPORATES SPECIAL FEATURES IMPORTANT FOR PROTECTION FROM X-RADIATION. FIRE AND ELECTRICAL SHOCK HAZARDS, WHEN SERVICING IF IS ESSENTIAL THAT ONLY MANUFACTURERS SPECIFIED PARTS BE USED FOR THE CRITICAL COMPONENTS IN THE Δ SYMBOL MARK OF THE SCHEMATIC.

SECRET
LGElectronics



MODEL	MID_POWER	DATE	2011.11.25
BLOCK		SHEET	24

RS-232C Control INTERFACE(NORTH AMERICA)

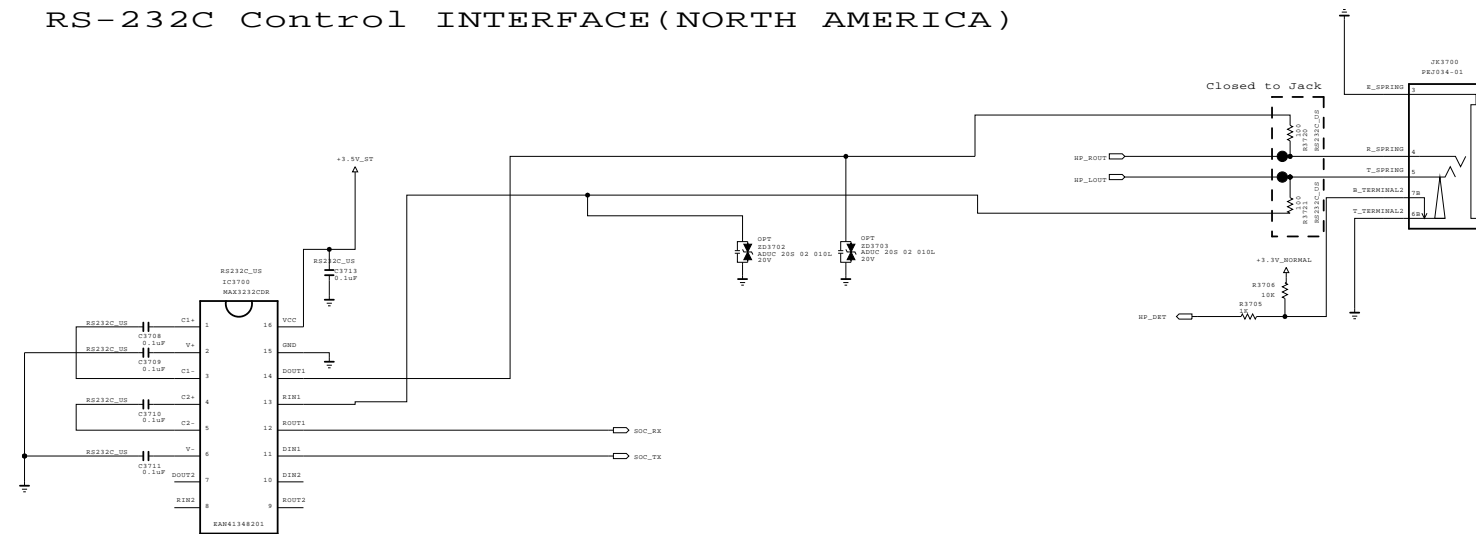

THE SYMBOL MARK OF THIS SCHEMATIC DIAGRAM INCORPORATES SPECIAL FEATURES IMPORTANT FOR PROTECTION FROM X-RADIATION. FIRE AND ELECTRICAL SHOCK HAZARDS, WHEN SERVICING IF IS ESSENTIAL THAT ONLY MANUFACTURERS SPECIFIED PARTS BE USED FOR THE CRITICAL COMPONENTS IN THE SYMBOL MARK OF THE SCHEMATIC.

SECRET
LGElectronics

LG ELECTRONICS

MODEL	14Y Phone Jack	DATE	2013.08.27
BLOCK		SHEET	537 /

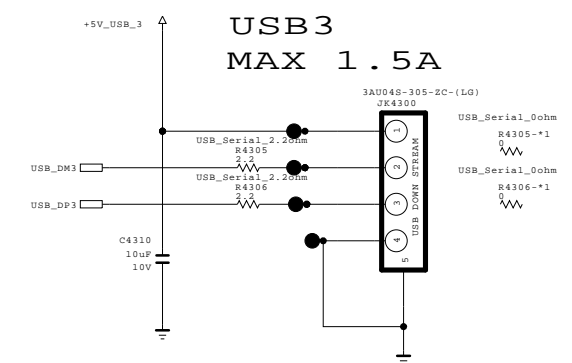
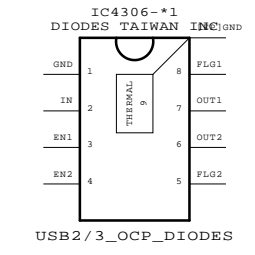
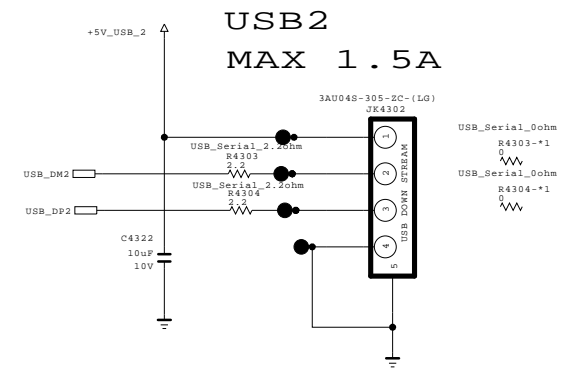
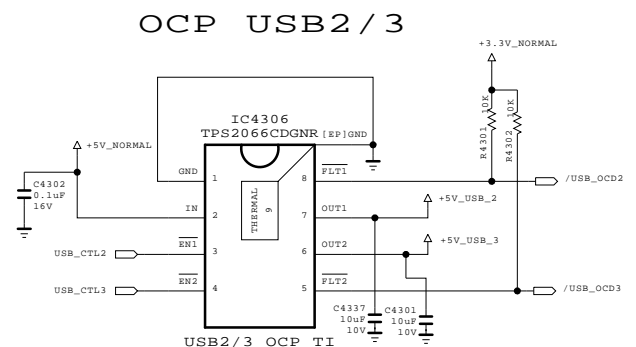
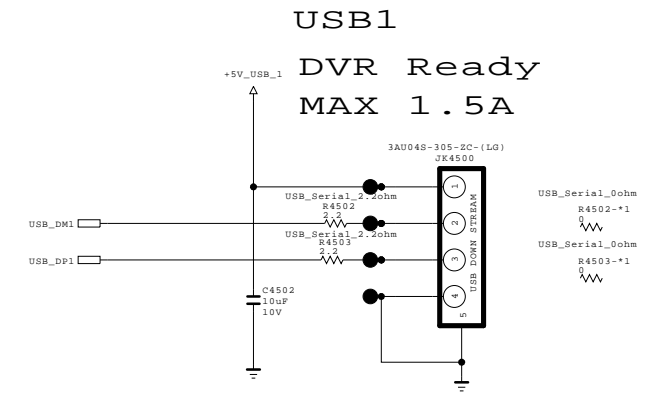
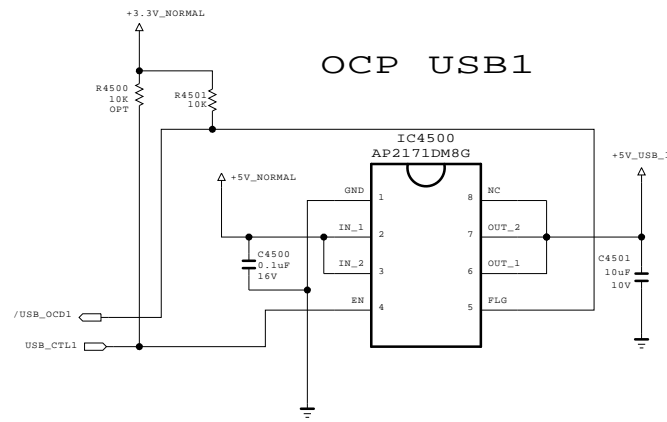

THE SYMBOL MARK OF THIS SCHEMATIC DIAGRAM INCORPORATES SPECIAL FEATURES IMPORTANT FOR PROTECTION FROM X-RADIATION. FIRE AND ELECTRICAL SHOCK HAZARDS, WHEN SERVICING IT IS ESSENTIAL THAT ONLY MANUFACTURERS SPECIFIED PARTS BE USED FOR THE CRITICAL COMPONENTS IN THE SYMBOL MARK OF THE SCHEMATIC.



SECRET
LGElectronics

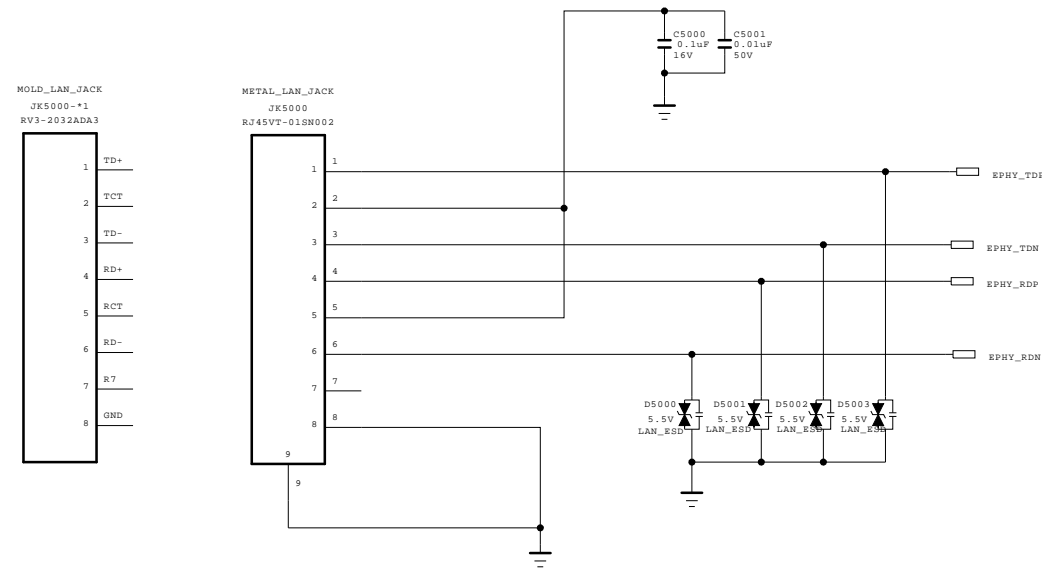

MODEL	USB2_USB3	DATE	2013.11.25
BLOCK		SHEET	543

Ethernet Block



THE  SYMBOL MARK OF THIS SCHEMATIC DIAGRAM INCORPORATES SPECIAL FEATURES IMPORTANT FOR PROTECTION FROM X-RADIATION. FIRE AND ELECTRICAL SHOCK HAZARDS, WHEN SERVICING IF IS ESSENTIAL THAT ONLY MANUFACTURERS SPECIFIED PARTS BE USED FOR THE CRITICAL COMPONENTS IN THE  SYMBOL MARK OF THE SCHEMATIC.

SECRET
LGElectronics



MODEL	LAN_VERTICAL	DATE	2013.11.26
BLOCK		SHEET	550 /

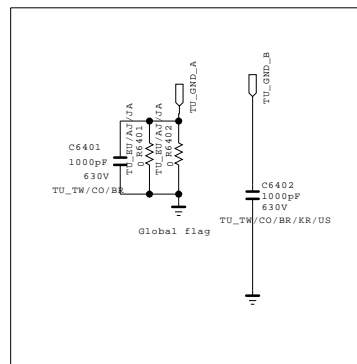
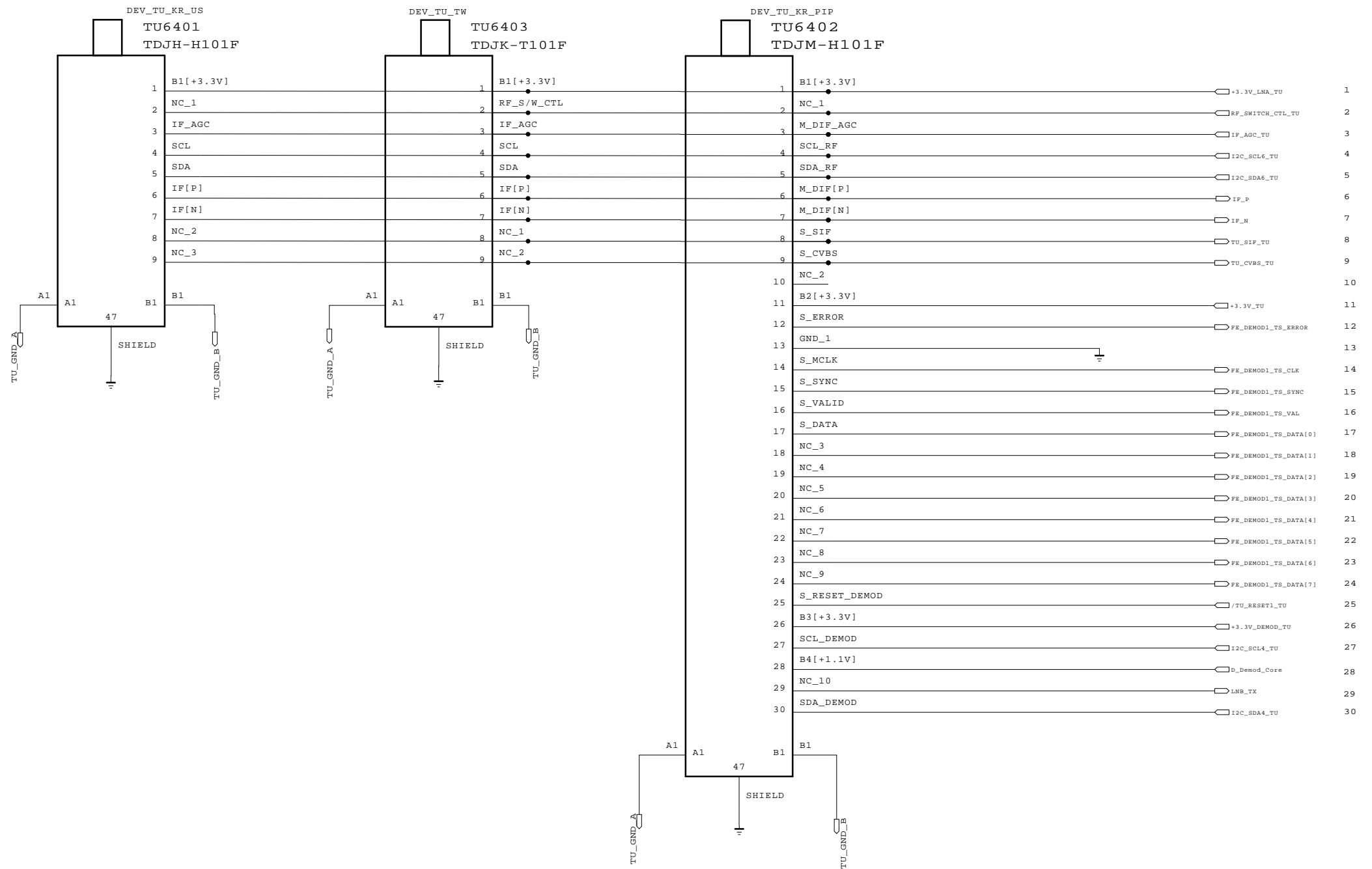
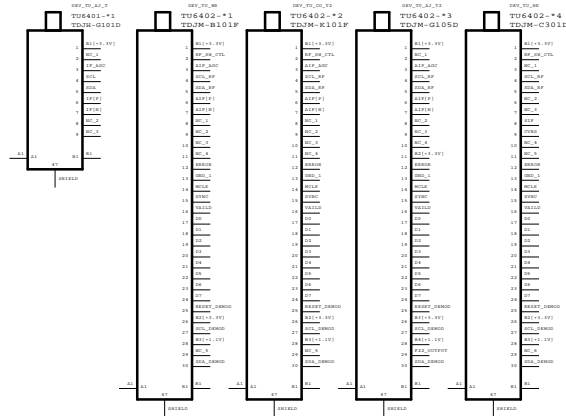

THE SYMBOL MARK OF THIS SCHEMATIC DIAGRAM INCORPORATES SPECIAL FEATURES IMPORTANT FOR PROTECTION FROM X-RADIATION. FIRE AND ELECTRICAL SHOCK HAZARDS, WHEN SERVICING IT IS ESSENTIAL THAT ONLY MANUFACTURERS SPECIFIED PARTS BE USED FOR THE CRITICAL COMPONENTS IN THE SYMBOL MARK OF THE SCHEMATIC.

SECRET
LGElectronics

LG ELECTRONICS

MODEL	TUNER	DATE	2013.07.16
BLOCK		SHEET	564 /

/TU_RESET2_TU /TU_RESET2
 FE_DEMOD1_TS_ERROR

1. should be guarded by ground
2. No via on both of them
3. Signal Width >= 12mils
Signal to Signal Width = 12mils
Ground Width >= 24mils

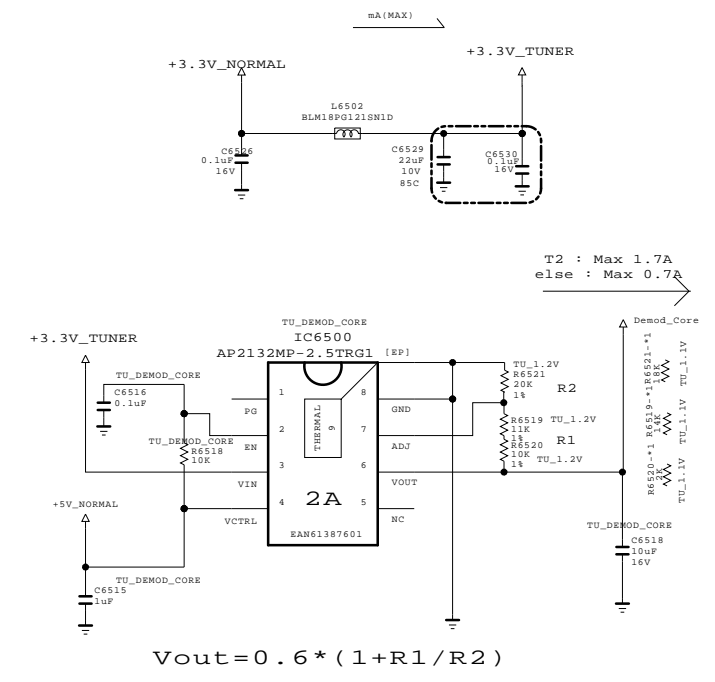
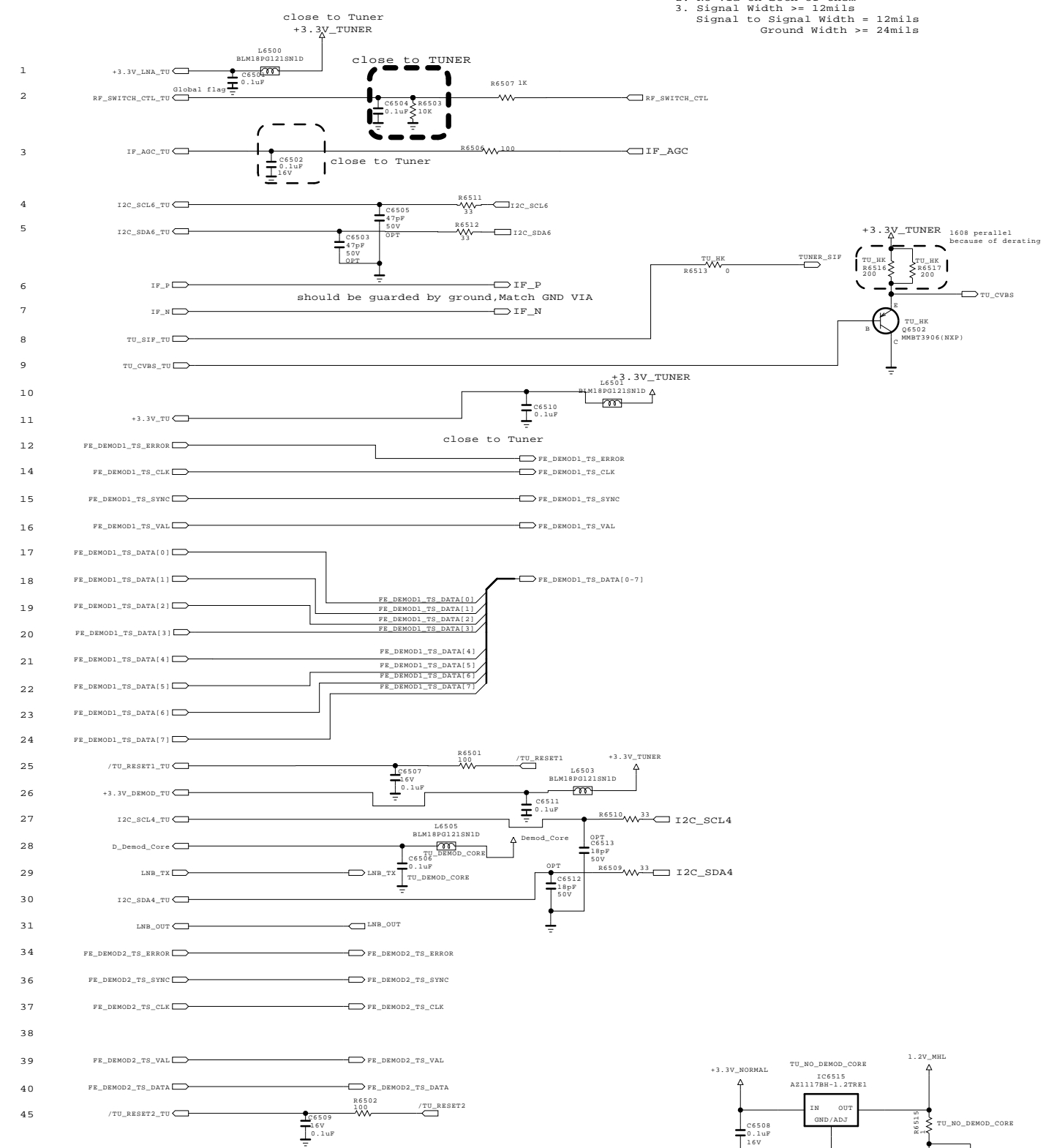

DELETE 1.8V POWER

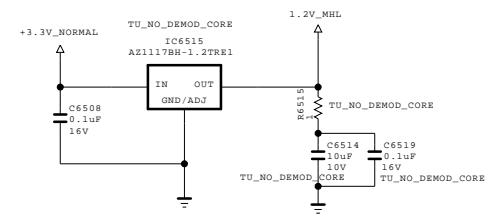

Global F/E Option Name
 1. TU
 2. Tuner Name = TDS'S', TDS'Q'...
 3. Country Name = T, T2, S2, KR, US, BR ...

Example of Option name
 TU_Q_T2 = apply TDSQ type tuner and T2 country
 TU_M/W = apply TDSM&TDSW Type Tuner

13' Tuner Type for Global
 TDS'S'-G501D : T/C Half NIM Horizontal Type
 TDS'Q'-G501D : T/C/S2 Combo Horizontal type
 TDS'Q'-G601D : T2/C/S2 Combo Horizontal Type
 TDS'Q'-G651D : T2/C/S2 Combo Vertical Type
 TDS'Q'-G705D : Singapore DVB-T2 (V1.3.1)
 TDS'M'-C601D : China NIM with Isolater Type
 TDS'W'-J551F : Japan Dual NIM
 TDS'W'-B651F : Brazil 2Tuner
 TDS'W'-A651F : Taiwan 2Tuner
 TDS'W'-K651F : Colombia DVB-T2 2Tuner

THE SYMBOL MARK OF THIS SCHEMATIC DIAGRAM INCORPORATES SPECIAL FEATURES IMPORTANT FOR PROTECTION FROM X-RADIATION. FIRE AND ELECTRICAL SHOCK HAZARDS, WHEN SERVICING IF IS ESSENTIAL THAT ONLY MANUFACTURERS SPECIFIED PARTS BE USED FOR THE CRITICAL COMPONENTS IN THE SYMBOL MARK OF THE SCHEMATIC.

SECRET
 LG Electronics



MODEL	TUNER_CIRCUIT	DATE	2013.07.16
BLOCK		SHEET	565

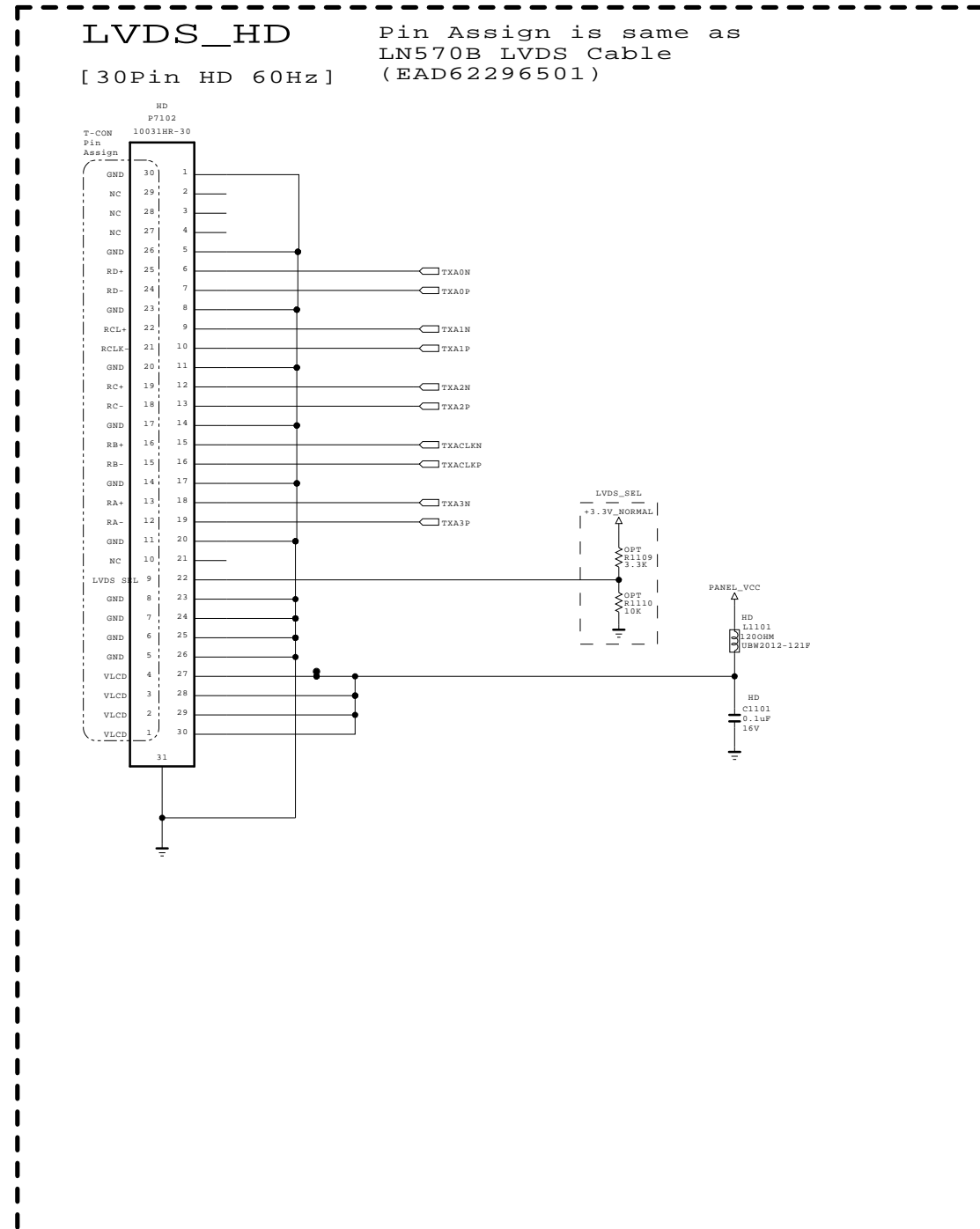
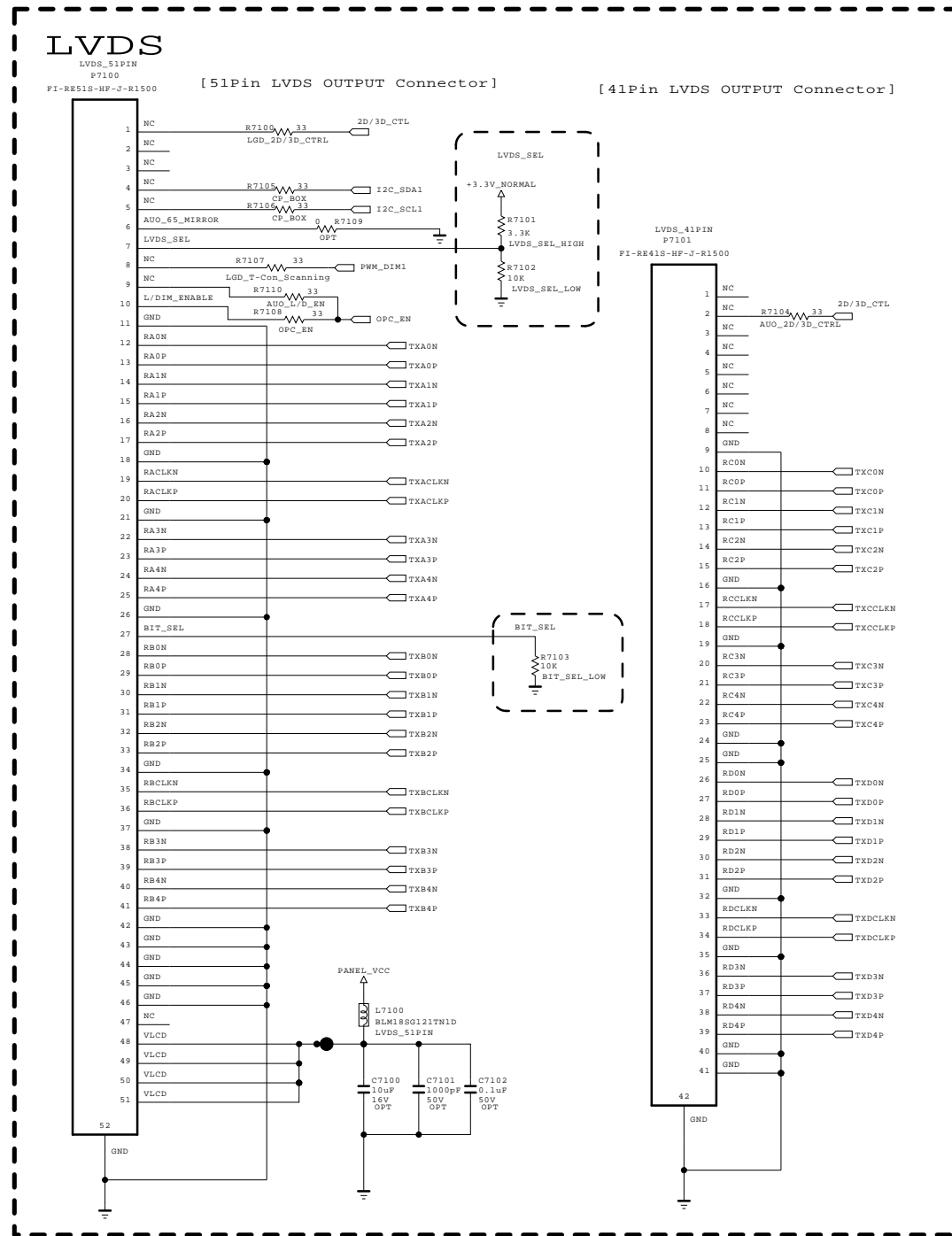

THE SYMBOL MARK OF THIS SCHEMATIC DIAGRAM INCORPORATES SPECIAL FEATURES IMPORTANT FOR PROTECTION FROM X-RADIATION. FIRE AND ELECTRICAL SHOCK HAZARDS, WHEN SERVICING IF IS ESSENTIAL THAT ONLY MANUFACTURERS SPECIFIED PARTS BE USED FOR THE CRITICAL COMPONENTS IN THE SYMBOL MARK OF THE SCHEMATIC.

SECRET
LGElectronics



MODEL	LVDS_HIGH_MID	DATE	2013.07.16
BLOCK		SHEET	571



Repair guide

Contents of LCD TV Standard Repair Process

No.	Error symptom (High category)	Error symptom (Mid category)	Page	Remarks
1	A. Video error	No video/Normal audio	1	
2		No video/No audio	2	
3		Video error, video lag/stop, fail tuning	3, 4	
4		Color error	5	
5		Vertical/Horizontal bar, residual image, light spot, external device color error	6	
6	B. Power error	No power	7	
7		Off when on, off while viewing, power auto on/off	8	
8	C. Audio error	No audio/Normal video	9	
9		Wrecked audio/discontinuation/noise	10	
10	D. Function error	No response in remote controller, key error, recording error, memory error	11	
11		External device recognition error	12	
12	E. Noise	Circuit noise, mechanical noise	13	
13	F. Exterior error	Exterior defect	14	
14	G. Network error	Connection defect / Network speed low	15	

First of all, Check whether there is SVC Bulletin in GCSC System for these model.

Standard Repair Process

LCD TV	Error symptom	A. Video error	Established date	2013. 12 .06	
		No video/ Normal audio	Revised date		

**First of all, Check whether all of cables between board is inserted properly or not.
(Main B/D ↔ Power B/D, LVDS Cable, Speaker Cable, IR B/D Cable,,)**

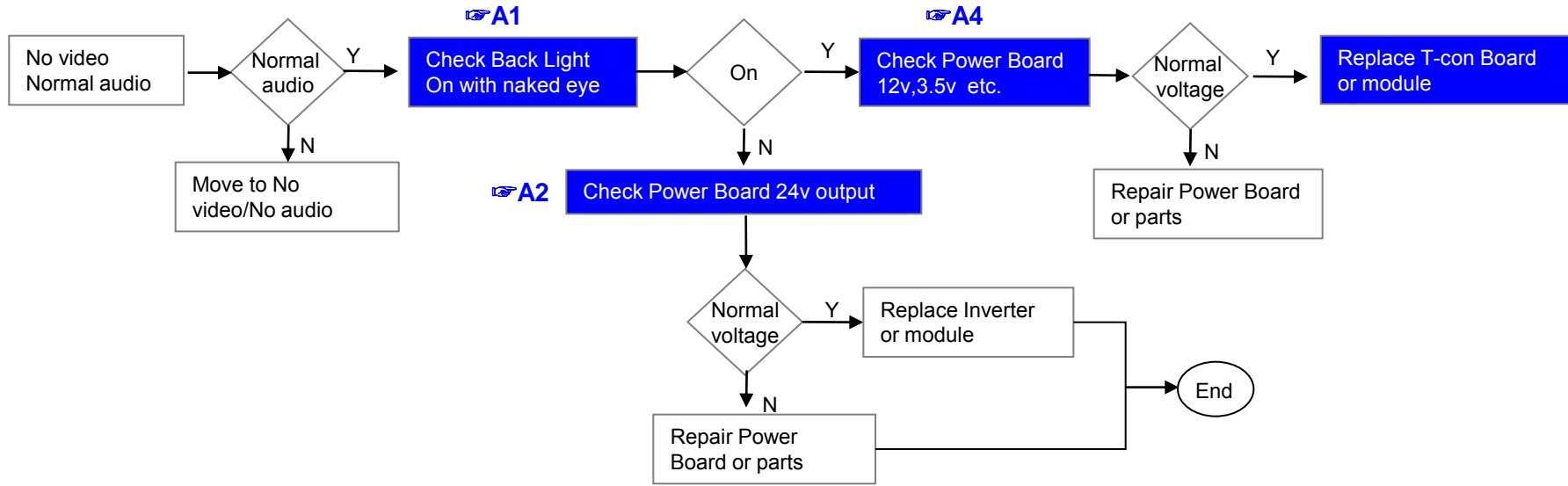

※ Precaution A7 & A3



Standard Repair Process

LCD TV

Error symptom

A. Video error

Established date

2013. 12 .06

No video/ No audio

Revised date

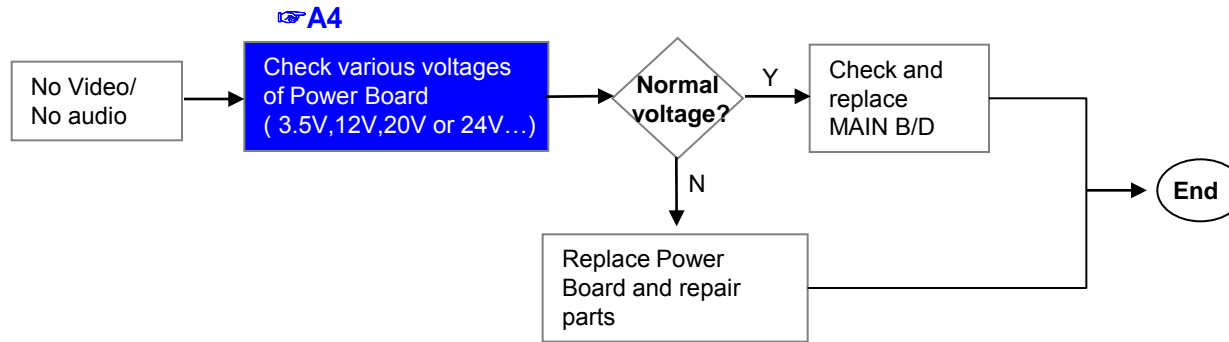

Standard Repair Process

LCD TV	Error symptom	A. Picture Problem	Established date	2013. 12 .06	
		Picture broken/ Freezing	Revised date		

A6

Check RF Signal level

- . By using Digital signal level meter
- . By using Diagnostics menu on OSD
(Menu → Set up → Support → Signal Test)
- Signal strength (Normal : over 50%)
- Signal Quality (Normal: over 50%)

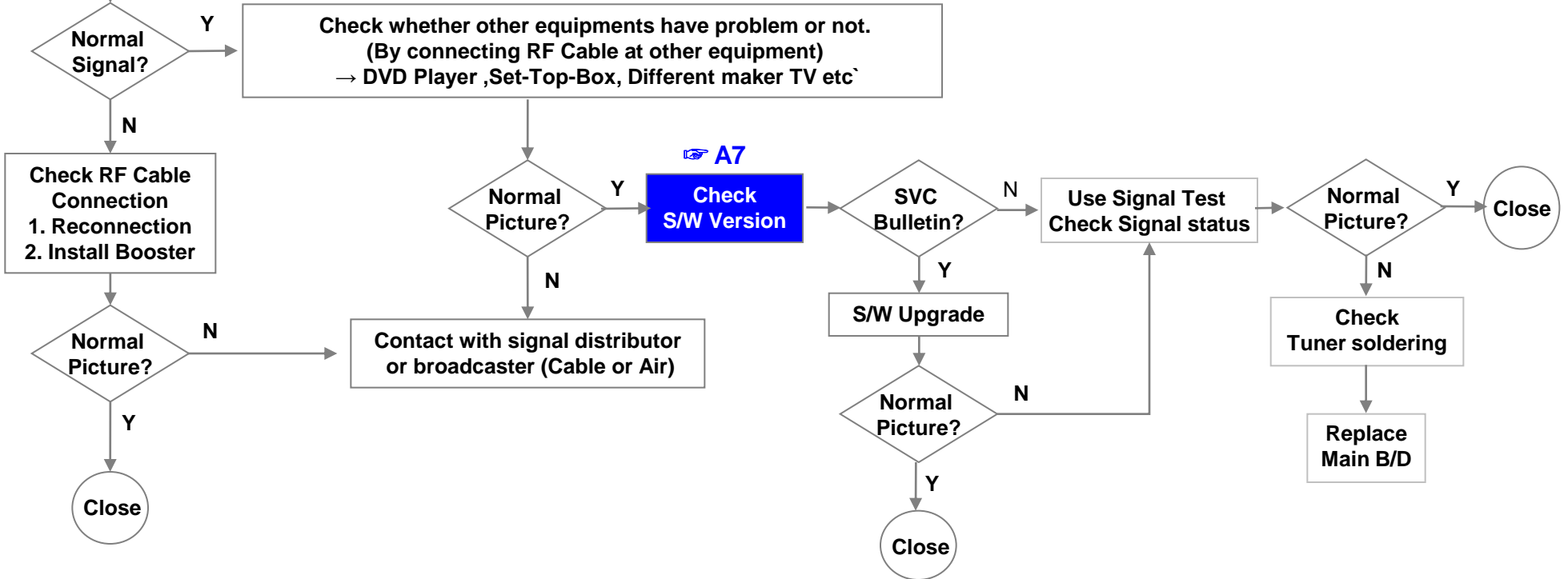

A7

Check S/W Version

Standard Repair Process

LCD TV	Error symptom	A. Picture Problem (DVB-S/S2)	Established date	2013. 12 .06	
		Tuning fail, Picture broken/ Freezing	Revised date		

👉 A6

Check RF Signal level

Check RF signal cable (DVB satellite signal or not)
 Check whether other equipments have problem or not.
 (By connecting RF Cable at other equipment)
 → Set-Top-Box, Different maker TV etc

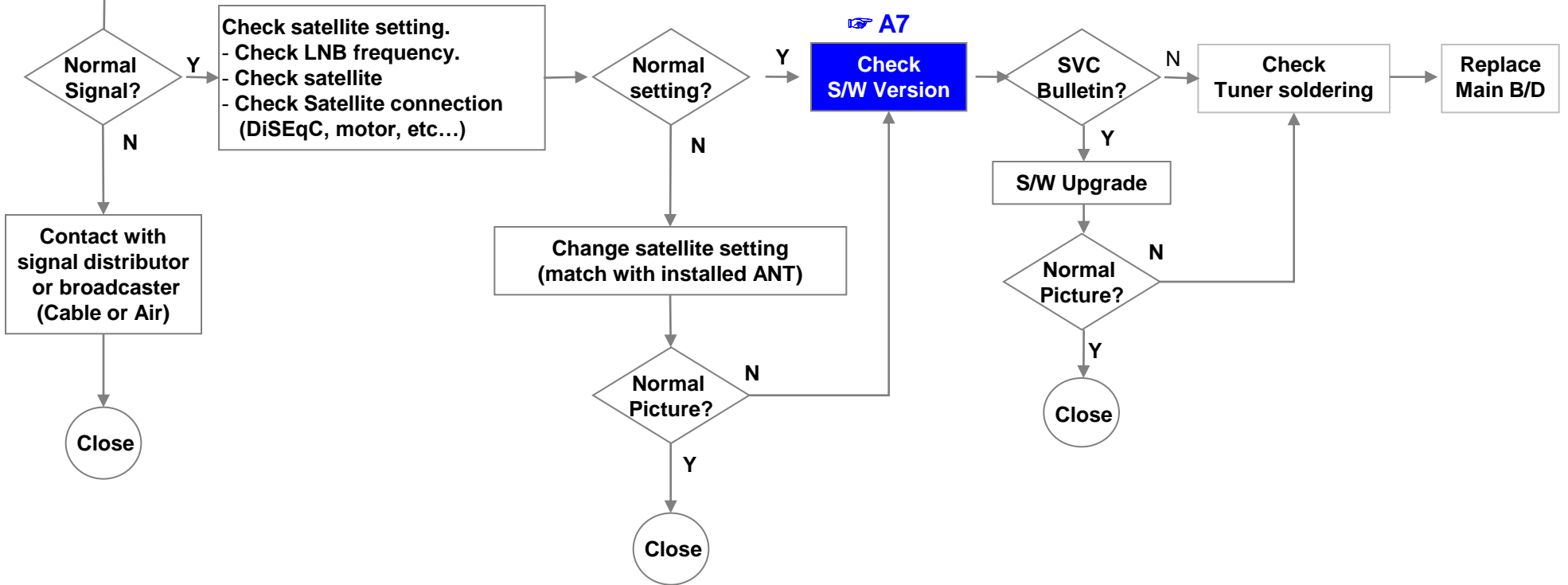

Standard Repair Process

LCD TV	Error symptom	A. Video error	Established date	2013. 12 .06	
		Color error	Revised date		

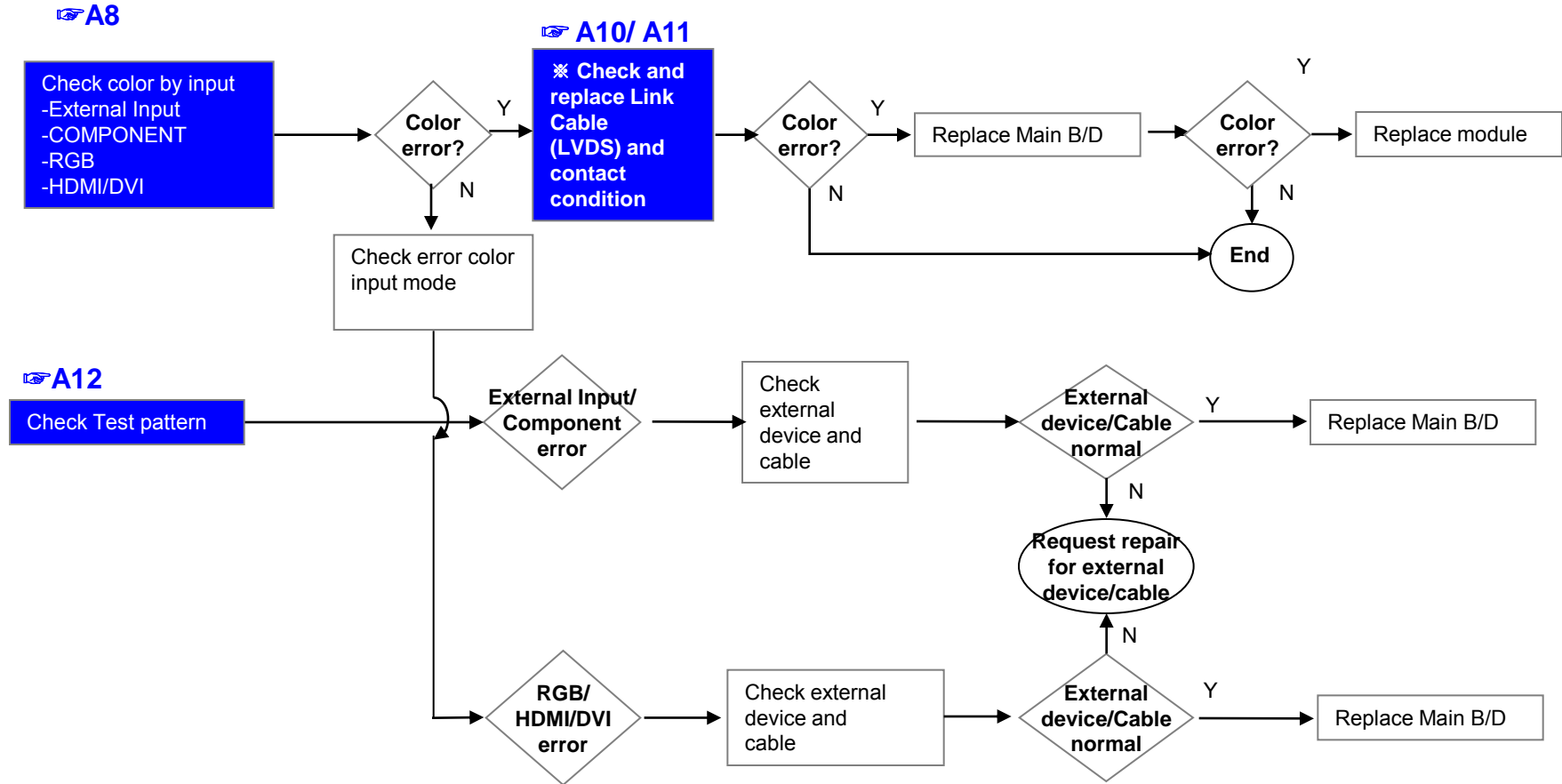

LCD TV	Error symptom	A. Video error	Established date	2013. 12 .06	
		Vertical / Horizontal bar, residual image, light spot, external device color error	Revised date		

Vertical/Horizontal bar, residual image, light spot

A8

Check color condition by input
 -External Input
 -Component
 -RGB
 -HDMI/DVI

A12

Check Test pattern

A10/ A11

Check and replace Link Cable

A28

Replace Main B/D (adjust VCOM)

For LGD panel

For other panel

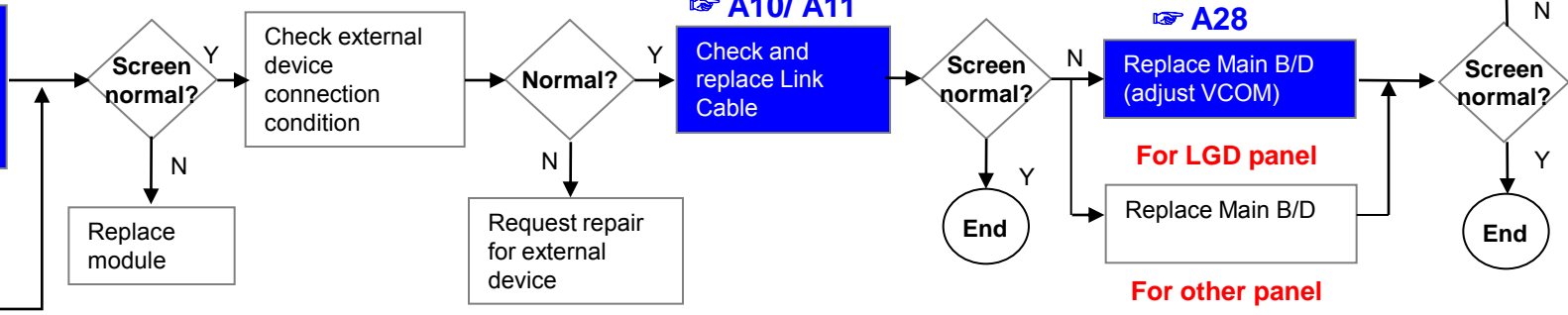

External device screen error-Color error

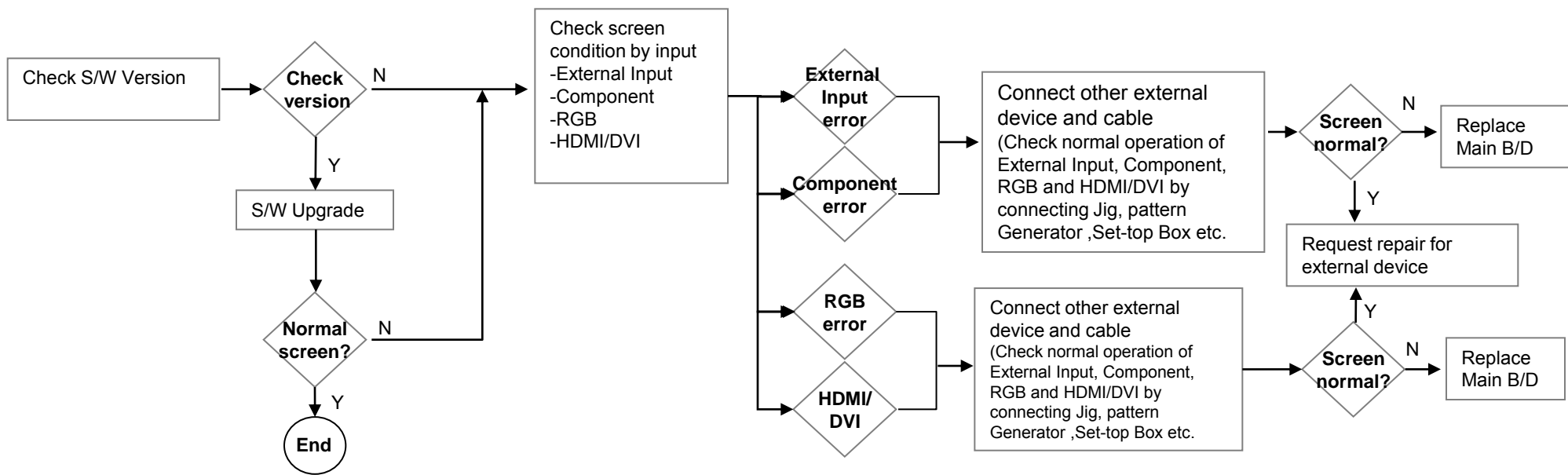

Standard Repair Process

LCD TV

Error symptom

B. Power error

Established date

2013. 12 .06

No power

Revised date

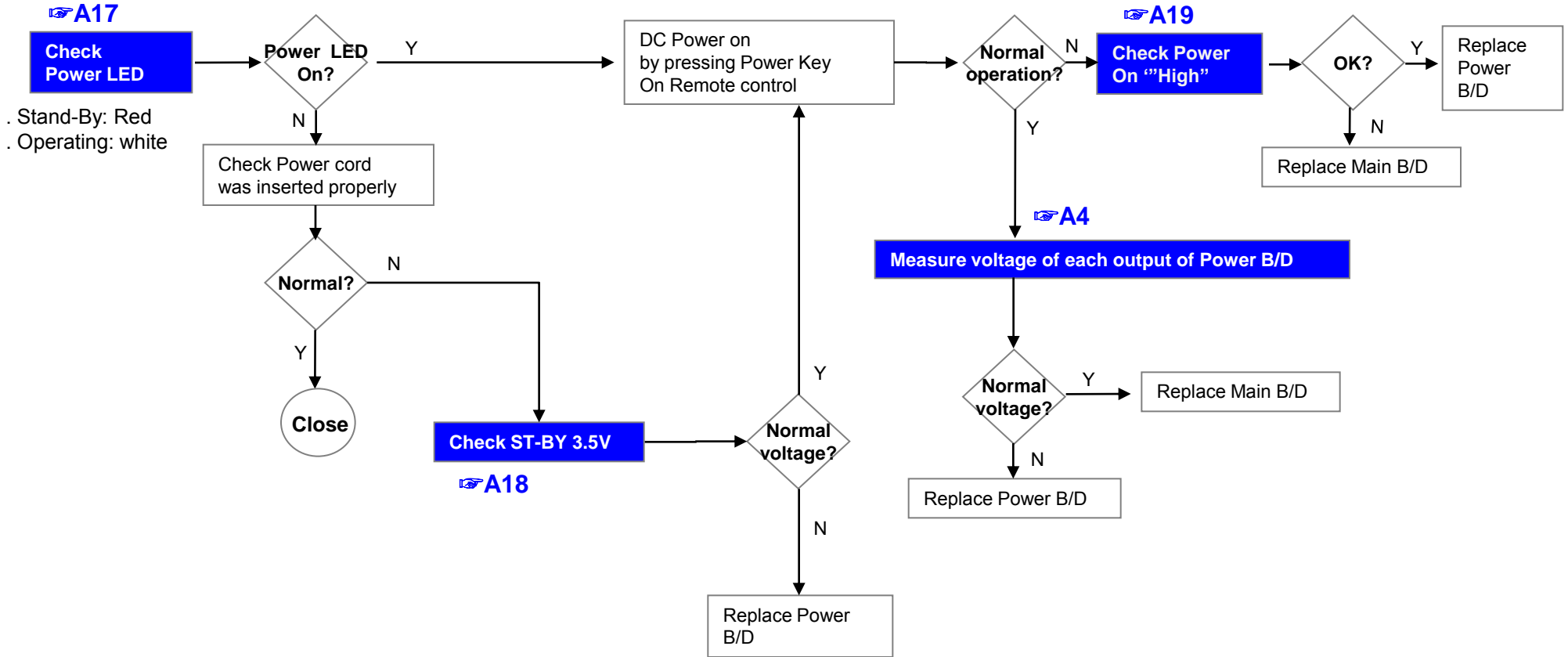

LCD TV	Error symptom	B. Power error	Established date	2013. 12 .06	
		Off when on, off while viewing, power auto on/off	Revised date		

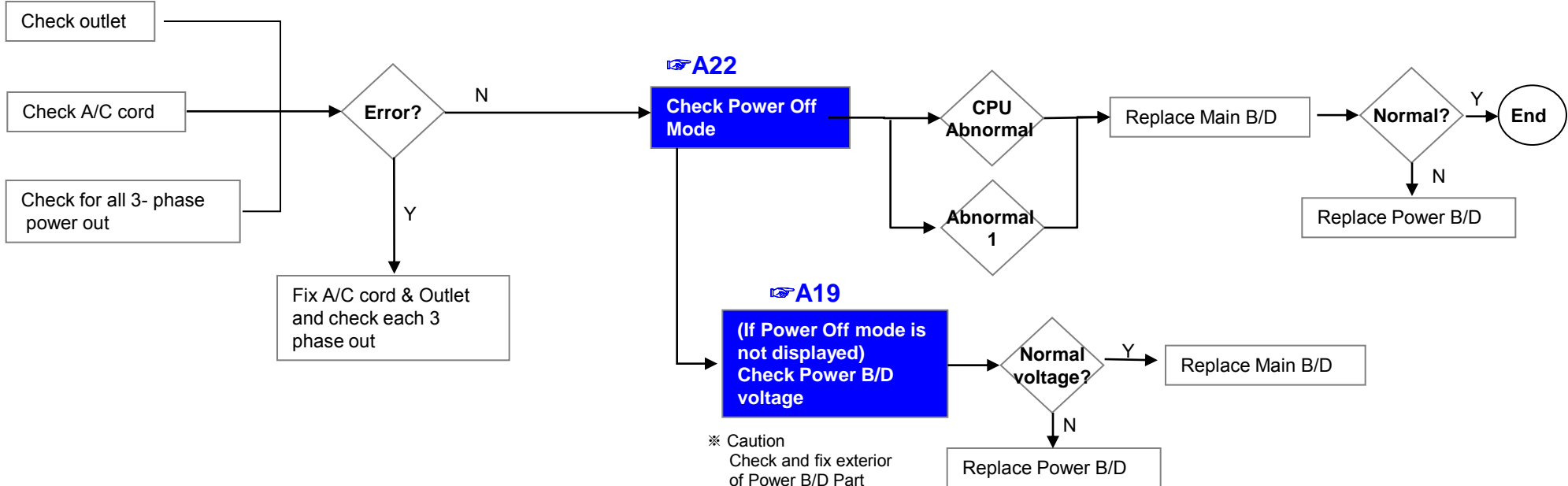

* Please refer to the all cases which can be displayed on power off mode.

Status	Power off List	Explanation
Normal	"POWEROFF_REMOTEKEY"	Power off by REMOTE CONTROL
	"POWEROFF_OFFTIMER"	Power off by OFF TIMER
	"POWEROFF_SLEEPTIMER"	Power off by SLEEP TIMER
	"POWEROFF_INSTOP"	Power off by INSTOP KEY
	"POWEROFF_AUTOOFF"	Power off by AUTO OFF
	"POWEROFF_ONTIMER"	Power off by ON TIMER
	"POWEROFF_RS232C"	Power off by RS232C
	"POWEROFF_RESREC"	Power off by Reserved Record
	"POWEROFF_RECEND"	Power off by End of Recording
	"POWEROFF_SWDOWN"	Power off by S/W Download
Abnormal	"POWEROFF_ABNORMAL1"	Power off by abnormal status except CPU trouble
	"POWEROFF_CPUABNORMAL"	Power off by CPU Abnormal

Standard Repair Process

LCD TV	Error symptom	C. Audio error	Established date	2013. 12 .06	
		No audio/ Normal video	Revised date		

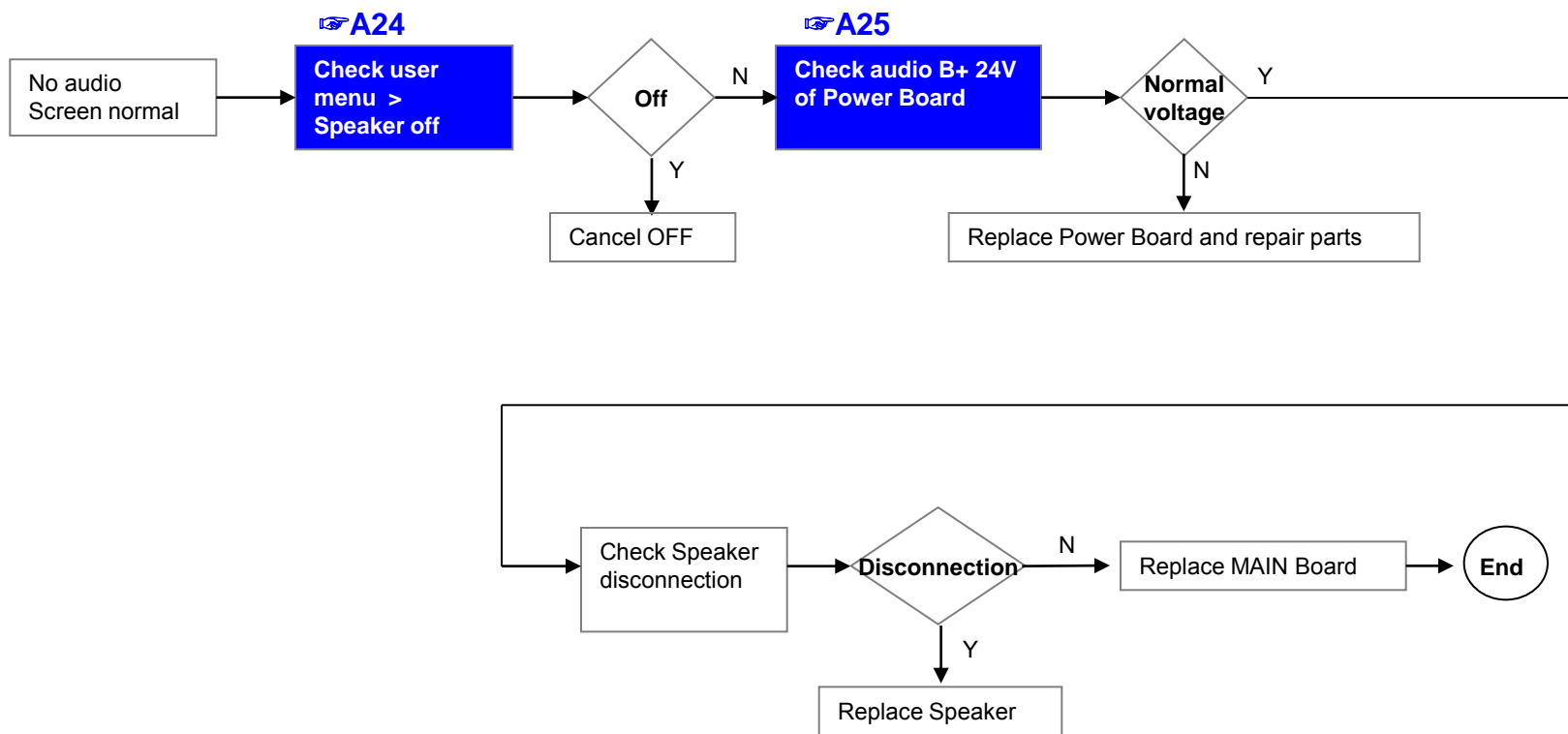

Standard Repair Process

LCD TV	Error symptom	C. Audio error	Established date	2013. 12 .06	
		Wrecked audio/ discontinuation/noise	Revised date		

→ abnormal audio/discontinuation/noise is same after “Check input signal” compared to No audio

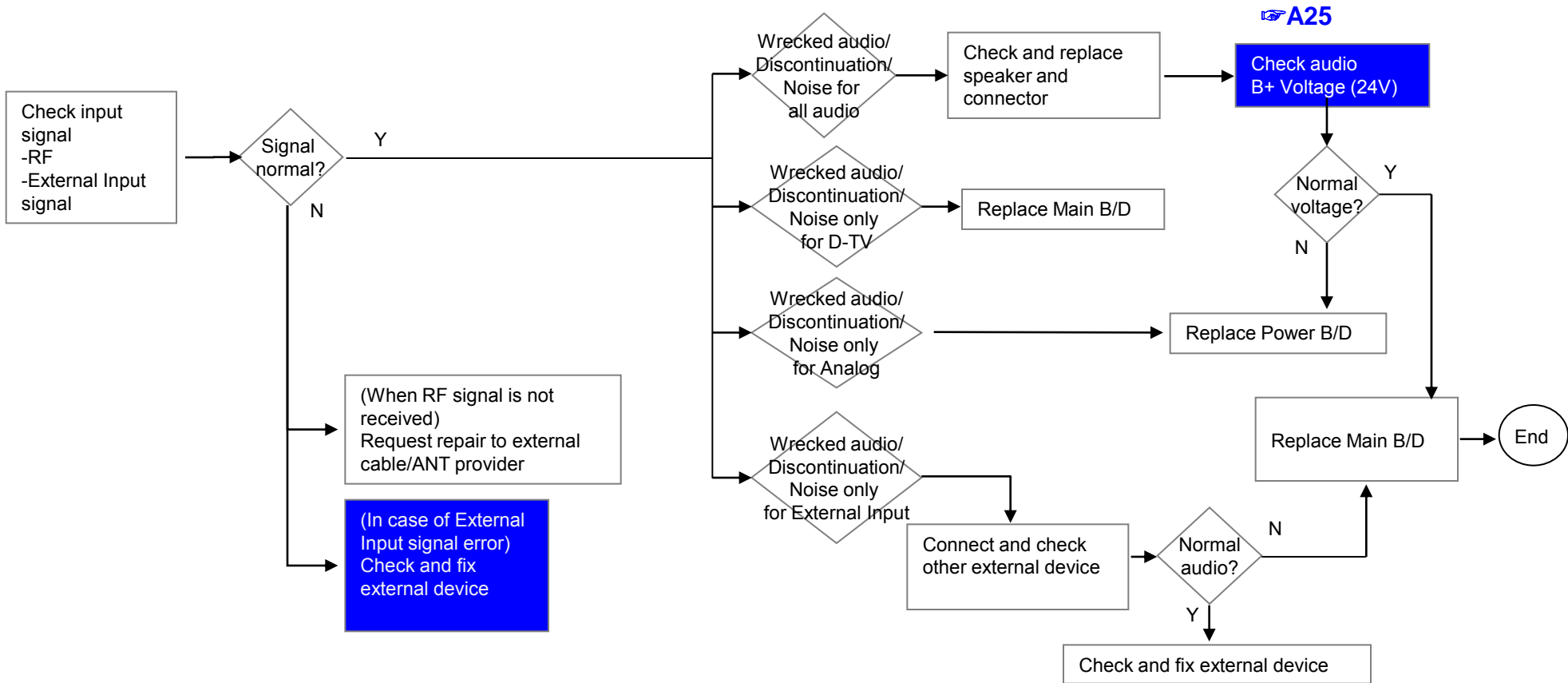

Standard Repair Process

LCD TV	Error symptom	D. General Function Problem	Established date	2013. 12 .06	
		Remote control & Local switch checking	Revised date		

1. Remote control(R/C) operating error

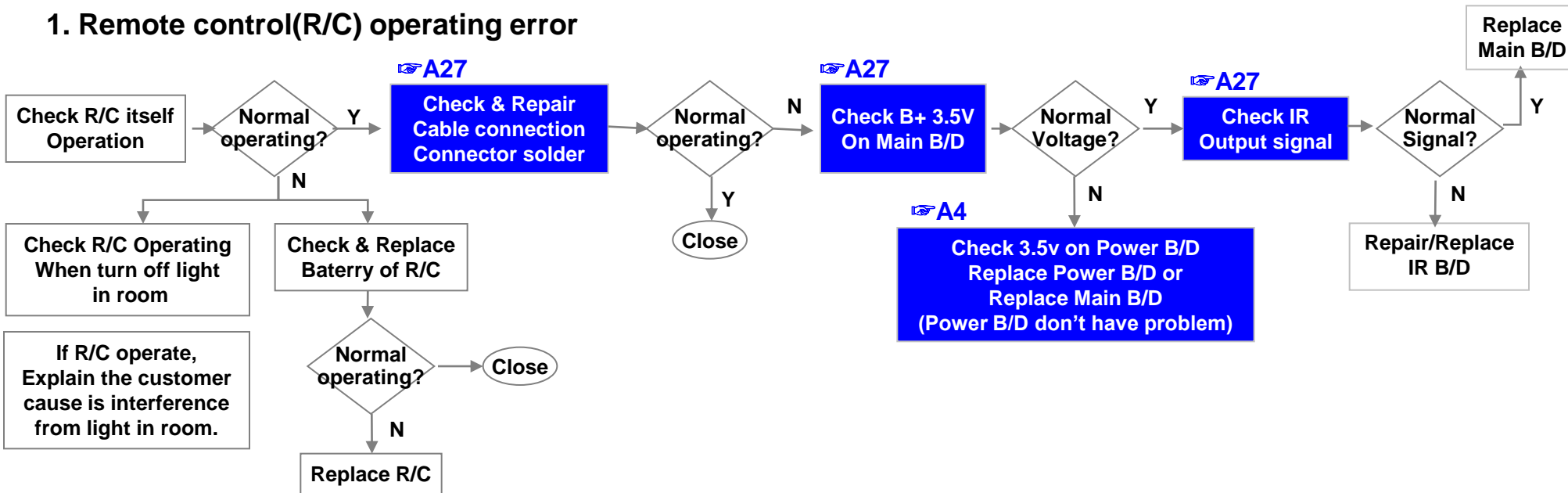

Standard Repair Process

LCD TV	Error symptom	D. Function error	Established date	2013. 12 .06	
		External device recognition error	Revised date		

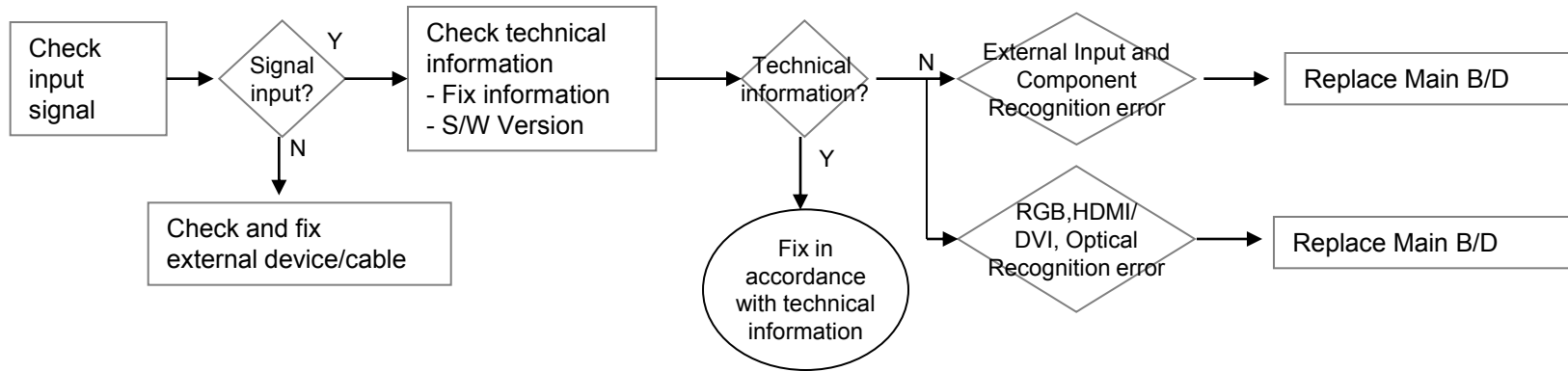

Standard Repair Process

LCD TV	Error symptom	E. Noise	Established date	2013. 12 .06	
		Circuit noise, mechanical noise	Revised date		

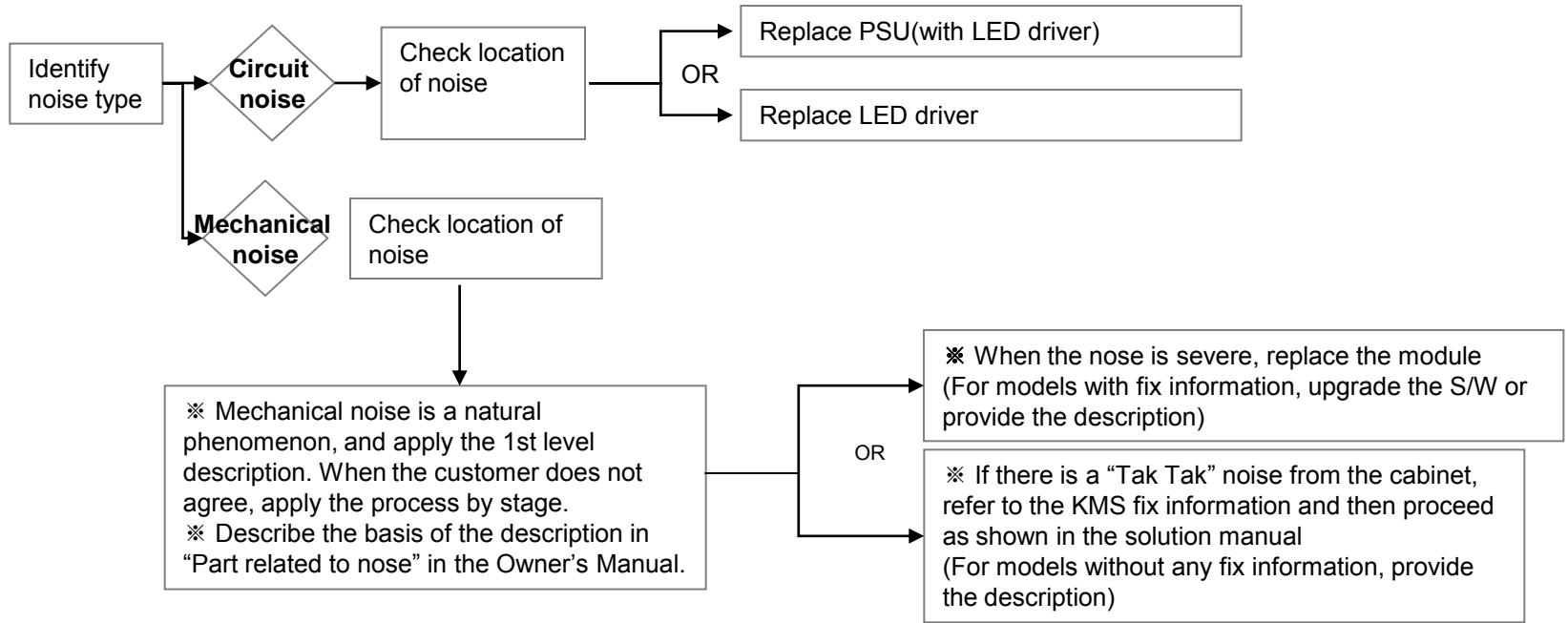

Standard Repair Process

LCD TV	Error symptom	F. Exterior defect	Established date	2013. 12 .06	
		Exterior defect	Revised date		

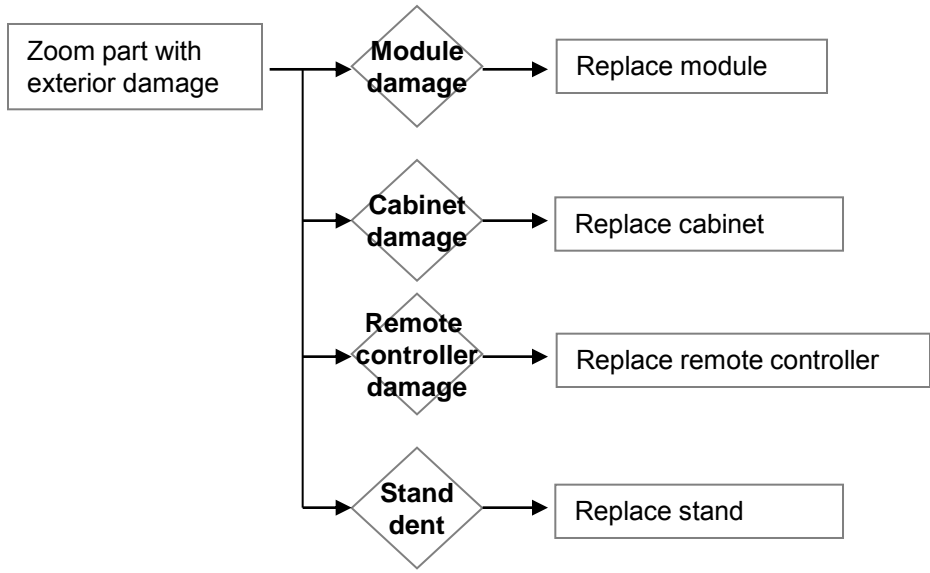

Standard Repair Process

LCD TV	Error symptom	G. Network Error	Established date	2013. 12 .06	
		Exterior defect	Revised date		

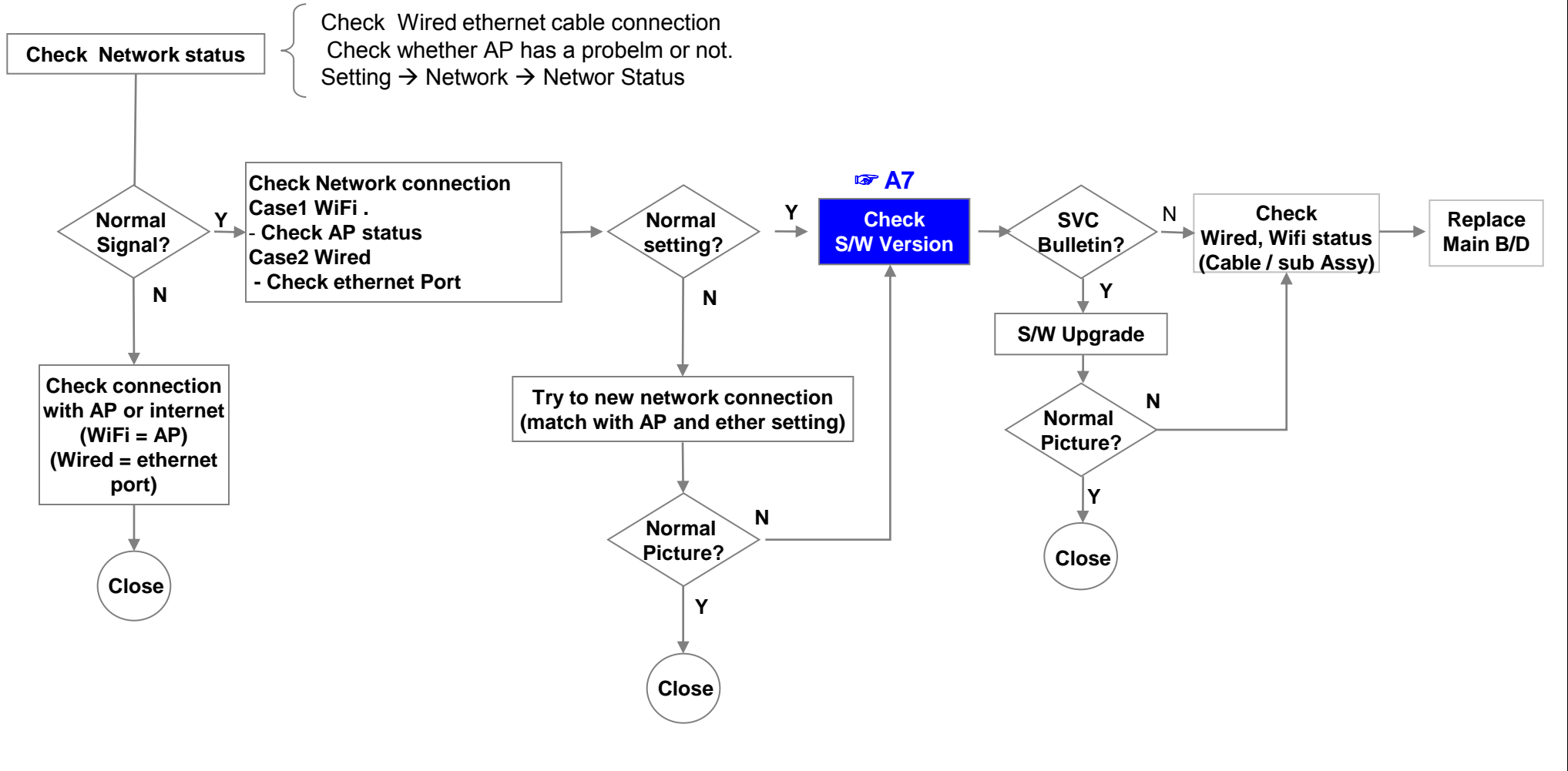

Standard Repair Process

LCD TV	Error symptom	G. CI+ Competibility Error	Established date	2013. 12 .06	
		Exterior defect	Revised date		

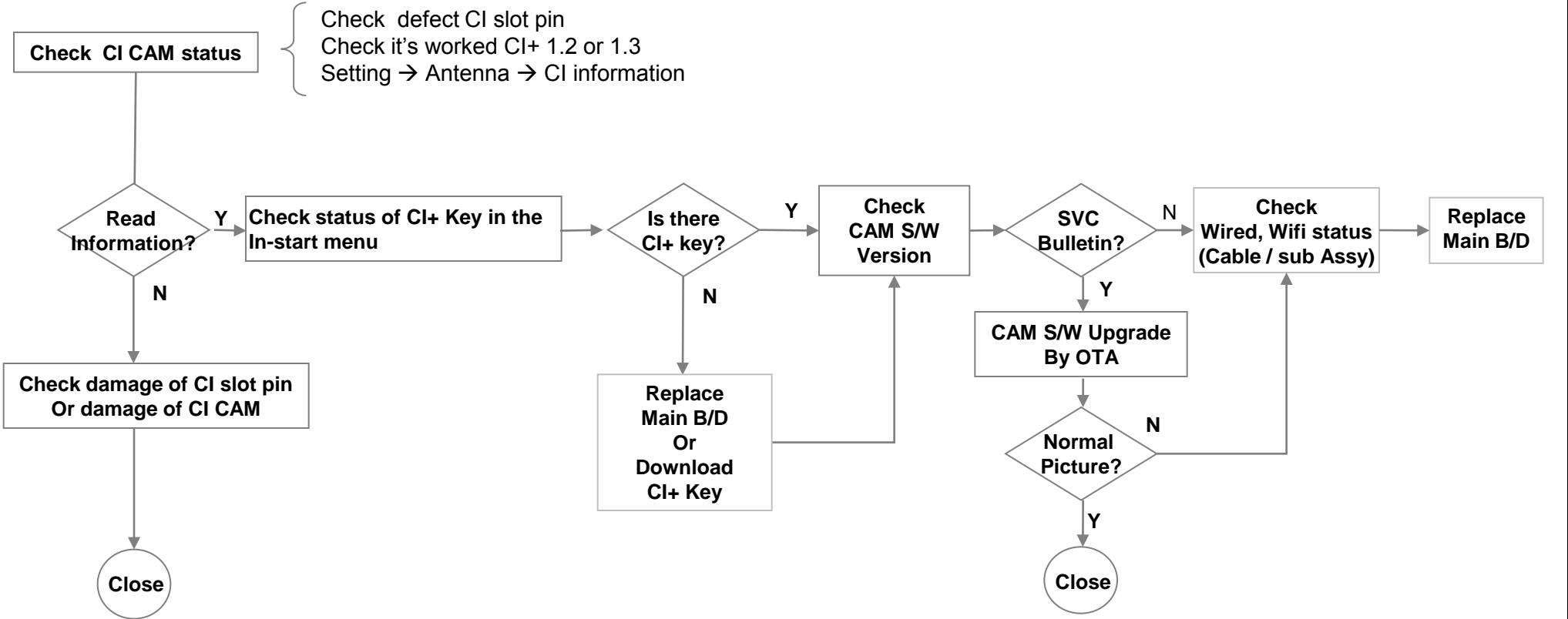

Old version of CI+ 1.2 CAM is not worked at the TV that is supported CI+ 1.3
 → Check SVC Bulletin

Contents of LCD TV Standard Repair Process Detail Technical Manual

No.	Error symptom	Content	Page	Remarks
1	A. Video error_ No video/Normal audio	Check LCD back light with naked eye	A1	
2		LED driver B+ 24V measuring method	A2	
3		Check White Balance value	A3	
4		Power Board voltage measuring method	A4	
6	A. Video error_ No video/Video lag/stop	TUNER input signal strength checking method	A6	
7		LCD-TV Version checking method	A7	
9	A. Video error_Color error	LCD TV connection diagram	A8	
10		Tuner Checking Part	A9	
11		Check Link Cable (LVDS) reconnection condition	A10 A11	
12		Adjustment Test pattern – ADJ Key	A12	
13		LCD TV connection diagram	A8	
14	A. Video error_Vertical/Horizontal bar, residual image, light spot	Check Link Cable (LVDS) reconnection condition	A10 A11	
15		Adjustment Test pattern – ADJ Key	A12	
16		Exchange T-Con Board (1)	A-1/5	
17	<Appendix> Defected Type caused by T-Con/ Inverter/ Module	Exchange T-Con Board (2)	A-2/5	
18		Exchange LED driver Board (PSU)	A-3/5	
19		Exchange Module itself (1)	A-4/5	
20		Exchange Module itself (2)	A-5/5	

Continue to the next page

Contents of LCD TV Standard Repair Process Detail Technical Manual

Continued from previous page

No.	Error symptom	Content	Page	Remarks
21	B. Power error_No power	Check front display LED	A17	
22		Check power input Voltage & ST-BY 3.5V	A18	
23		Checking method when power is ON	A19	
24		POWER BOARD voltage measuring method	A5	
25				
26	B. Power error_Off when on, off while viewing	POWER OFF MODE checking method	A22	
27	B. Power error_Off when on, off while viewing	POWER BOARD PIN voltage checking method	A19	
28	C. Audio error_No audio/Normal video	Checking method in menu when there is no audio	A24	
29		Voltage and speaker checking method when there is no audio	A25	
30	C. Audio error_Wrecked audio/discontinuation	Voltage and speaker checking method in case of audio error	A25	
31	D. Function error_ No response in remote controller, key error	Remote controller operation checking method	A27	
32	D. VCOM Adjustment	Sequence of the Vcom adjustment	A28	

Standard Repair Process Detail Technical Manual

LCD TV	Error symptom	A. Video error_No video/Normal audio	Established date	2013. 12 .06	
	Content	Check LCD back light with naked eye	Revised date		A1

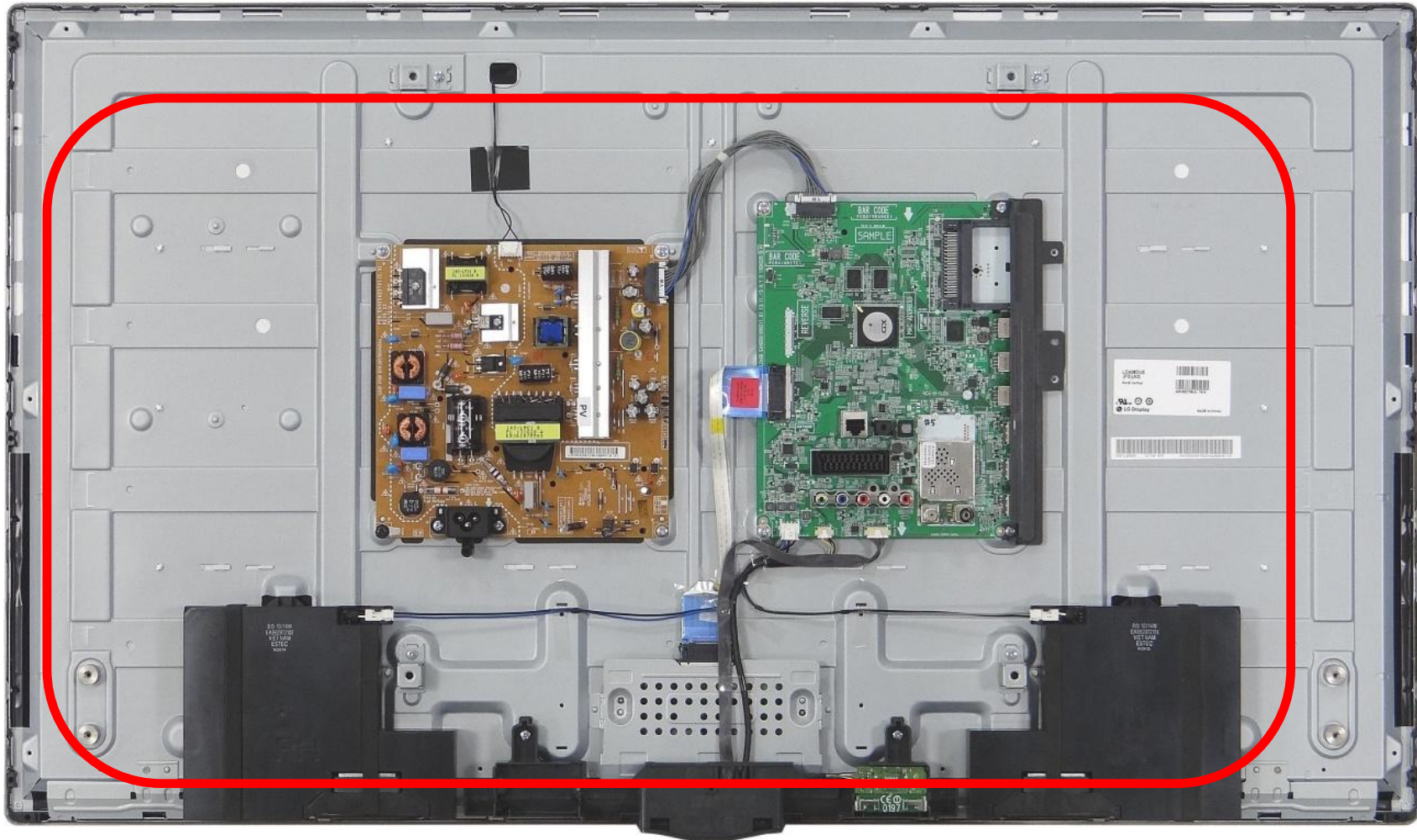

After turning on the power and disassembling the case, check with the naked eye, whether you can see light from module holes.

Standard Repair Process Detail Technical Manual

LCD TV	Error symptom	A. Video error_No video/Normal audio	Established date	2013. 12 .06	
	Content	LED driver B+ 24V measuring method	Revised date		A2



Check the DC 24V

18 Pin	
9, 10	24V

Standard Repair Process Detail Technical Manual

LCD TV	Error symptom	A. Video error_No video/Normal audio	Established date	2013. 12 .06	
	Content	Check White Balance value	Revised date		A4

<ALL MODELS>

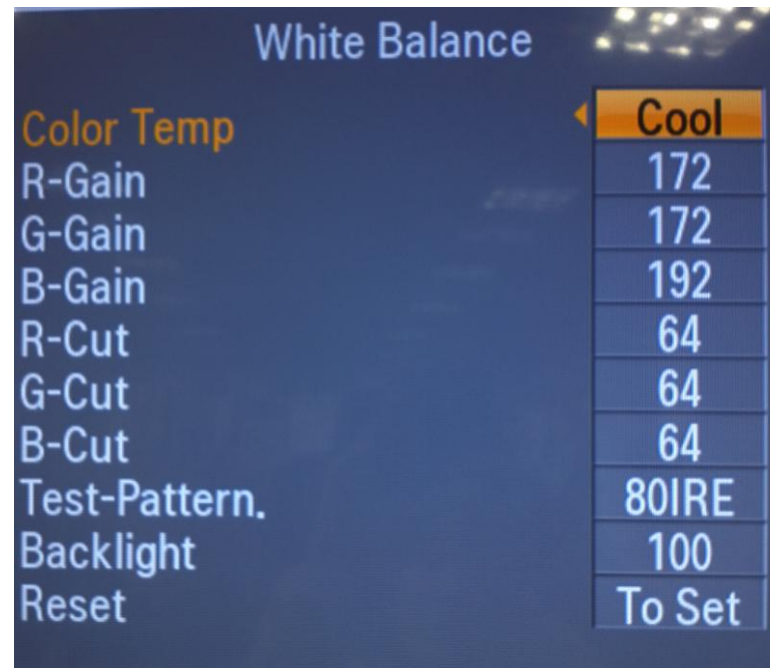
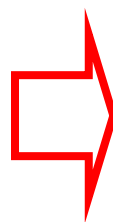
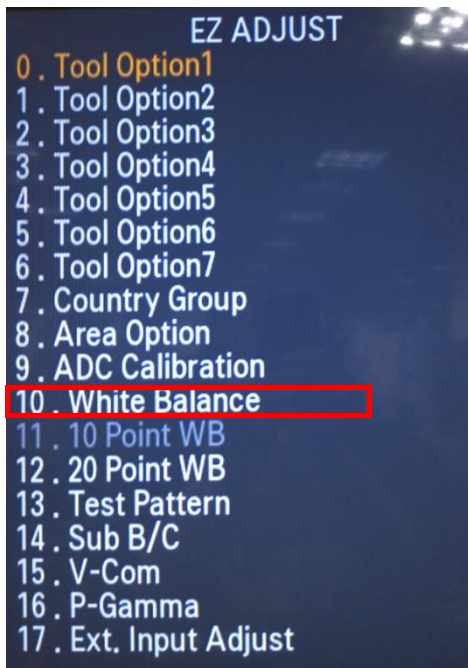

Entry method

1. Press the ADJ button on the remote controller for adjustment.
2. Enter into White Balance of item 10.
3. After recording the R, G, B (GAIN, Cut) value of Color Temp (Cool/Medium/Warm), re-enter the value after replacing the MAIN BOARD.

Standard Repair Process Detail Technical Manual

LCD TV	Error symptom	A. Video error_No video/ Audio	Established date	2013. 12 .06	
	Content	Power Board voltage measuring method	Revised date		A4



Check the 12V, 3.5V.

18 Pin (Power Board ↔ Main Board)			
1	Power on	2	DRV-ON
3	3.5V	4	P-DIM
5	3.5V	6	3.5V
7	GND	8	N.C
9	24V	10	24V
11	GND	12	GND
13	12V	14	12V
15	12V	16	N.C
17	GND	18	GND

Standard Repair Process Detail Technical Manual

LCD TV	Error symptom	A. Video error_No video/ Audio	Established date	2013. 12 .06	
	Content	Power Board voltage measuring method	Revised date		A5

Check the DC 24V, 12V, 3.5V.

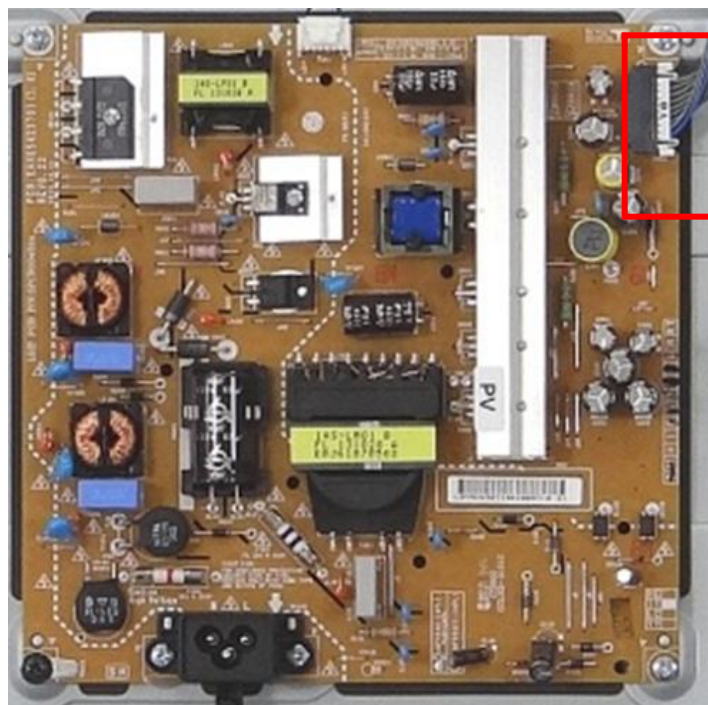

18 Pin (Power Board ↔ Main Board)

1	Power on	2	DRV-ON
3	3.5V	4	P-DIM
5	3.5V	6	3.5V
7	GND	8	N.C
9	24V	10	24V
11	GND	12	GND
13	12V	14	12V
15	12V	16	N.C
17	GND	18	GND

Standard Repair Process Detail Technical Manual

LCD TV	Error symptom	A. Video error_Video error, video lag/stop	Established date	2013. 12 .06	
	Content	TUNER input signal strength checking method	Revised date		A6

<ALL MODELS>

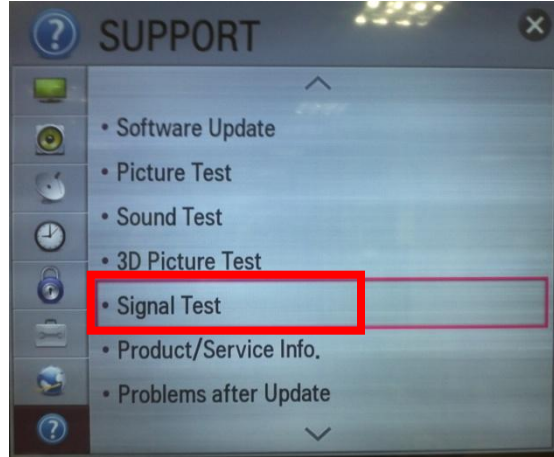

MENU → support → signal test
→ select channel

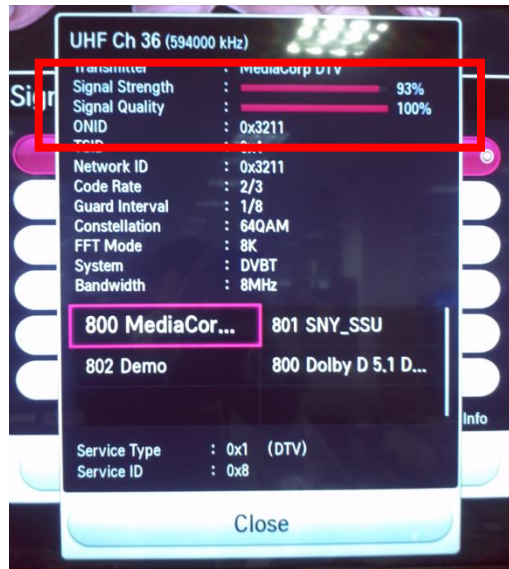

When the signal is strong, use the attenuator (-10dB, -15dB, -20dB etc.)



Standard Repair Process Detail Technical Manual

LCD TV	Error symptom	A. Video error_Video error, video lag/stop	Established date	2013. 12 .06	
	Content	LCD-TV Version checking method	Revised date		A7

<ALL MODELS>

1. Checking method for remote controller for adjustment

Version

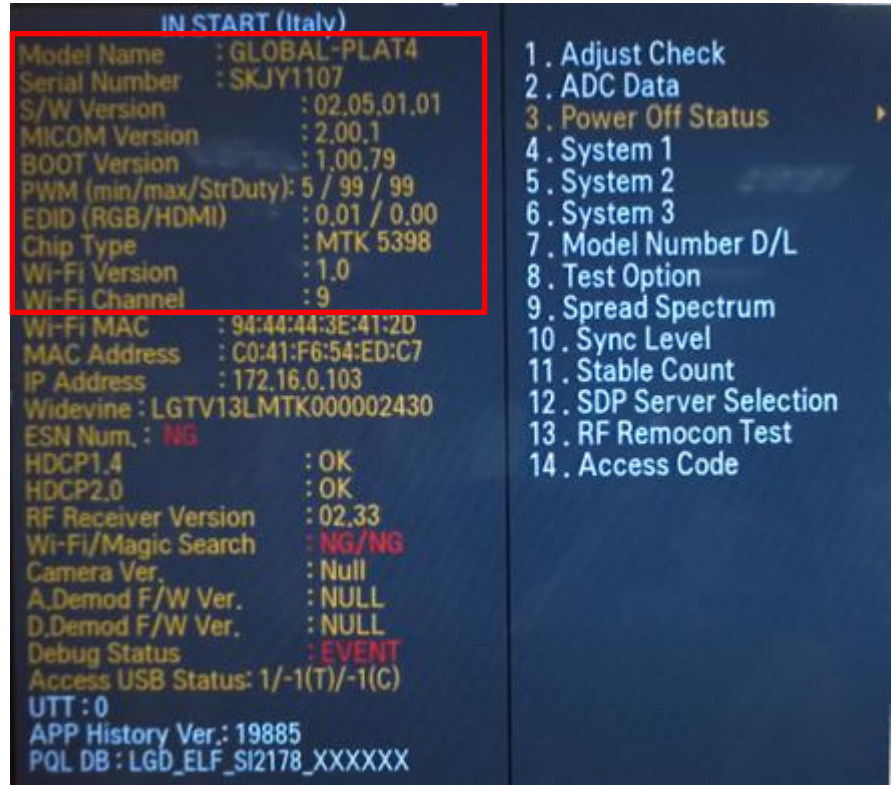

Press the IN-START with the remote controller for adjustment

Standard Repair Process Detail Technical Manual

LCD TV	Error symptom	A. Video error _Vertical/Horizontal bar, residual image, light spot	Established date	2013. 12 .06	
	Content	LCD TV connection diagram (1)	Revised date		A8

<ALL MODELS>



As the part connecting to the external input, check the screen condition by signal

Standard Repair Process Detail Technical Manual

LCD TV	Error symptom	A. Video error_Video error, video lag/stop	Established date	2013. 12 .06	
	Content	TUNER checking part	Revised date		A9

<ALL MODELS>



Checking method:

1. Check the signal strength or check whether the screen is normal when the external device is connected.
2. After measuring each voltage from power supply, finally replace the MAIN BOARD.

Standard Repair Process Detail Technical Manual

LCD TV	Error symptom	A. Video error_Color error	Established date	2013. 12 .06	
	Content	Check Link Cable (LVDS) reconnection condition	Revised date		A10

FHD (60Hz)



FHD (120Hz)

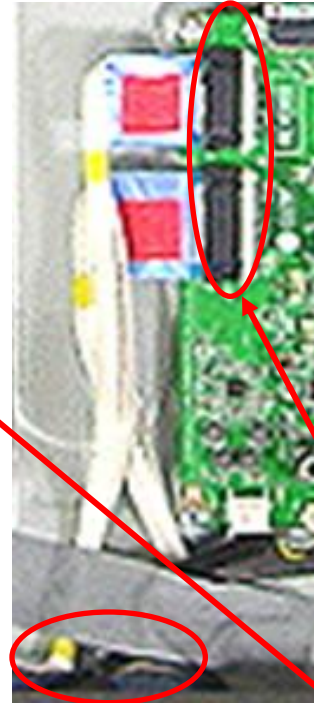

Check the contact condition of the Link Cable, especially dust or mis insertion.

Standard Repair Process Detail Technical Manual

LCD TV	Error symptom	A. Video error_Color error	Established date	2013. 12 .06	
	Content	Check Link Cable (LVDS) reconnection condition	Revised date		A11

HD

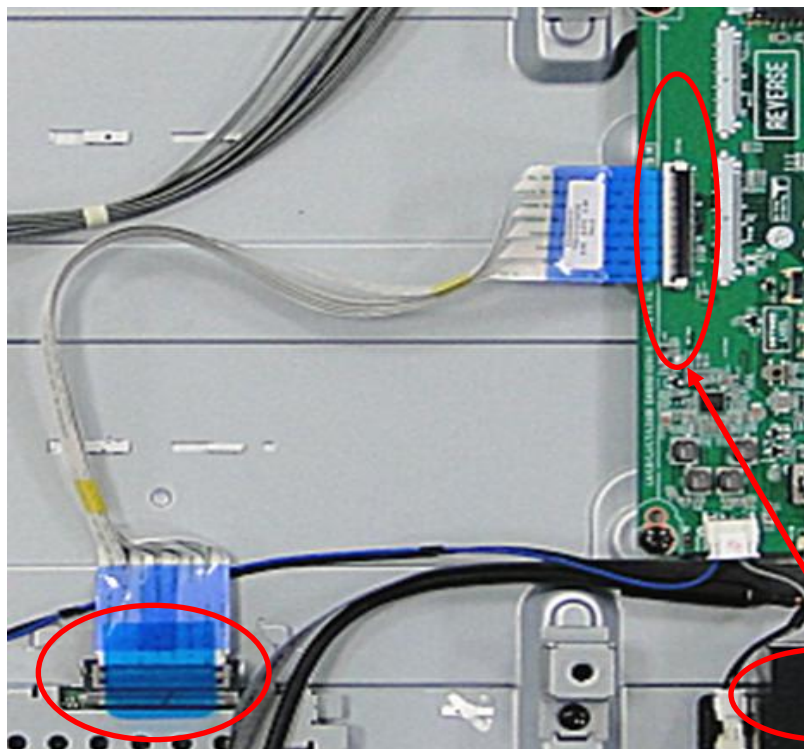

Check the contact condition of the Link Cable, especially dust or mis insertion.

Standard Repair Process Detail Technical Manual

LCD TV	Error symptom	A. Video error_Color error	Established date	2013. 12 .06	
	Content	Adjustment Test pattern - ADJ Key	Revised date		A12



- EZ ADJUST
- 0. Tool Option1
 - 1. Tool Option2
 - 2. Tool Option3
 - 3. Tool Option4
 - 4. Tool Option5
 - 5. Tool Option6
 - 6. Tool Option7
 - 7. Country Group
 - 8. Area Option
 - 9. ADC Calibration
 - 10. White Balance
 - 11. 10 Point WB
 - 12. 20 Point WB
 - 13. Test Pattern
 - 14. Sub B/C
 - 15. V-Com
 - 16. P-Gamma
 - 17. Ext. Input Adjust



You can view 6 types of patterns using the ADJ Key

Checking item : 1. Defective pixel 2. Residual image 3. MODULE error (ADD-BAR,SCAN BAR..)
4.Video error (Classification of MODULE or Main-B/D!)

Appendix : Exchange EPI Cable or Main B/D (1)



Solder defect, CNT Broken

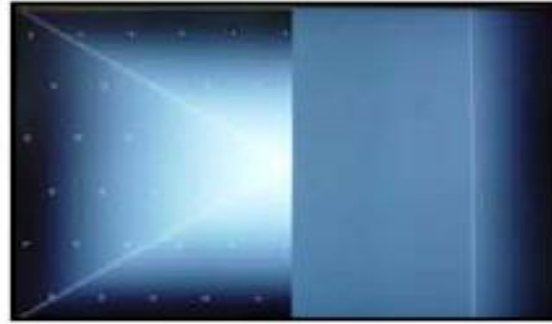

Solder defect, CNT Broken

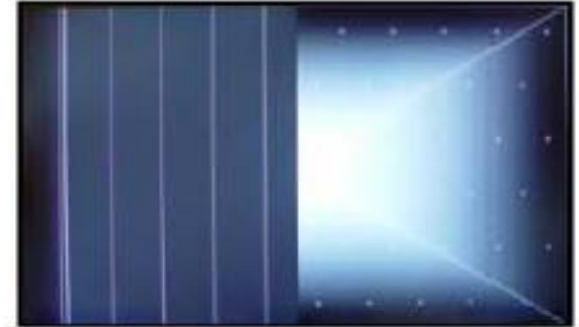

Solder defect, CNT Broken



Solder defect, CNT Broken

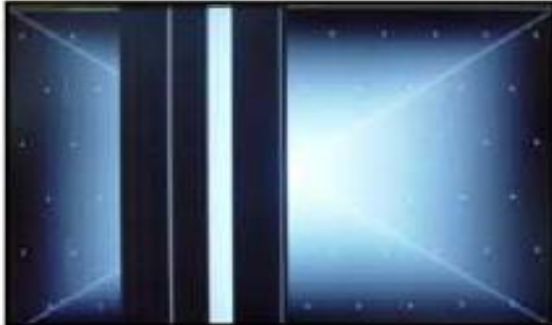

Solder defect, CNT Broken



Abnormal Power Section

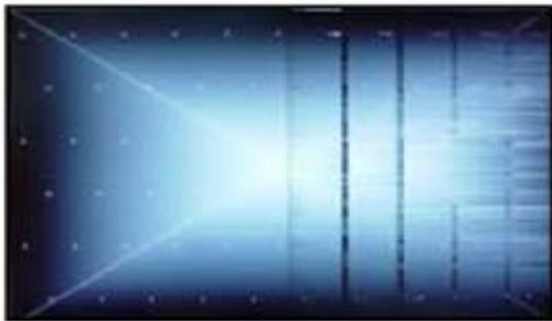

Solder defect, Short/Crack



Abnormal Power Section



Solder defect, Short/Crack

Appendix : Exchange EPI Cable or Main B/D (2)

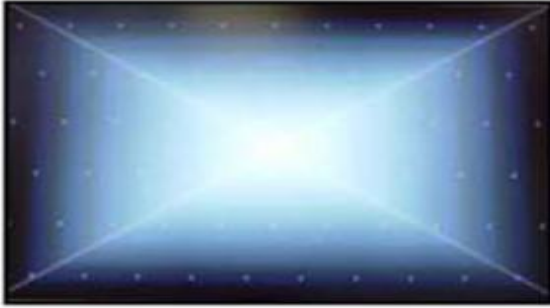

Abnormal Power Section



Abnormal Power Section



Solder defect, Short/Crack



Solder defect, Short/Crack



Fuse Open, Abnormal power section



Abnormal Display

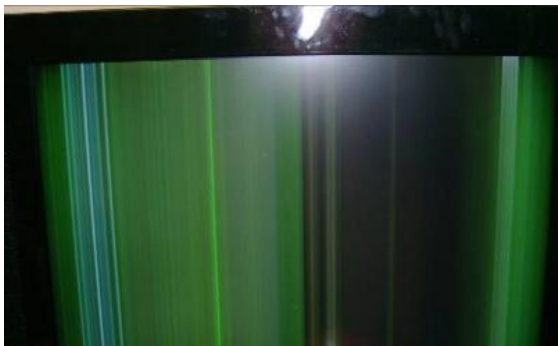

GRADATION



Noise



GRADATION

Appendix : Exchange LPB(LED driver)



No Light



Dim Light



Dim Light

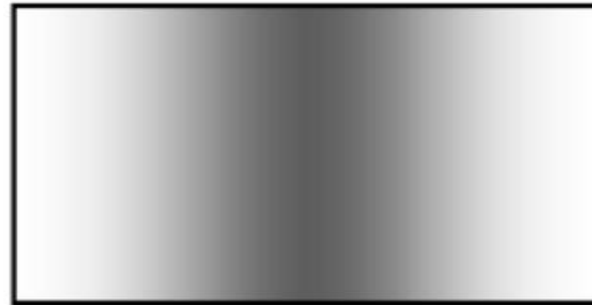

Dim Light

Appendix : Exchange the Module (1)



Panel Mura, Light leakage



Panel Mura, Light leakage



Press damage

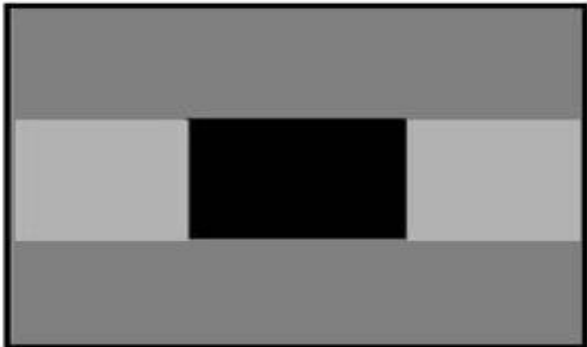

Crosstalk



Press damage



Crosstalk



Press damage

Un-repairable Cases

In this case please exchange the module.

Appendix : Exchange the Module (2)

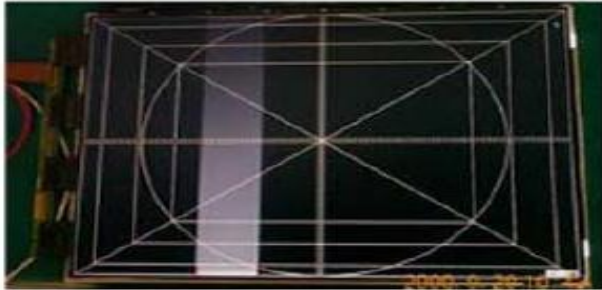

Vertical Block
Source TAB IC Defect



Vertical Line
Source TAB IC Defect



Vertical Block
Source TAB IC Defect



Horizontal Block
Gate TAB IC Defect

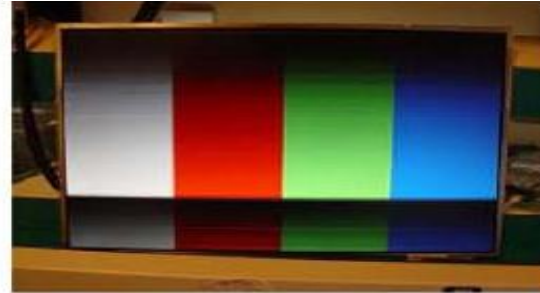

Horizontal Block
Gate TAB IC Defect

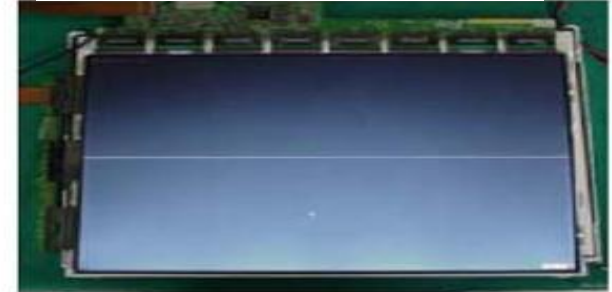

Horizontal line
Gate TAB IC Defect

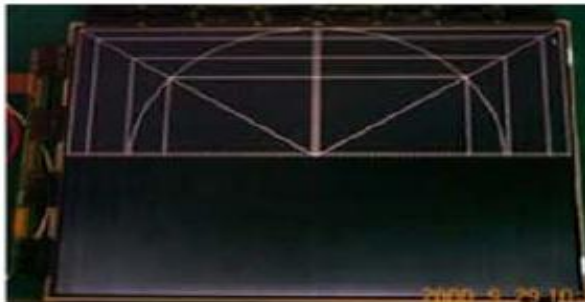

Horizontal Block
Gate TAB IC Defect

Un-repairable Cases

In this case please exchange the module.

Standard Repair Process Detail Technical Manual

LCD TV	Error symptom	B. Power error _No power	Established date	2013. 12 .06	
	Content	Check front display LED	Revised date		A17

A type : LB49**-ZH, LB57**,
LB58**-ZA/ZB/ZG/ZJ

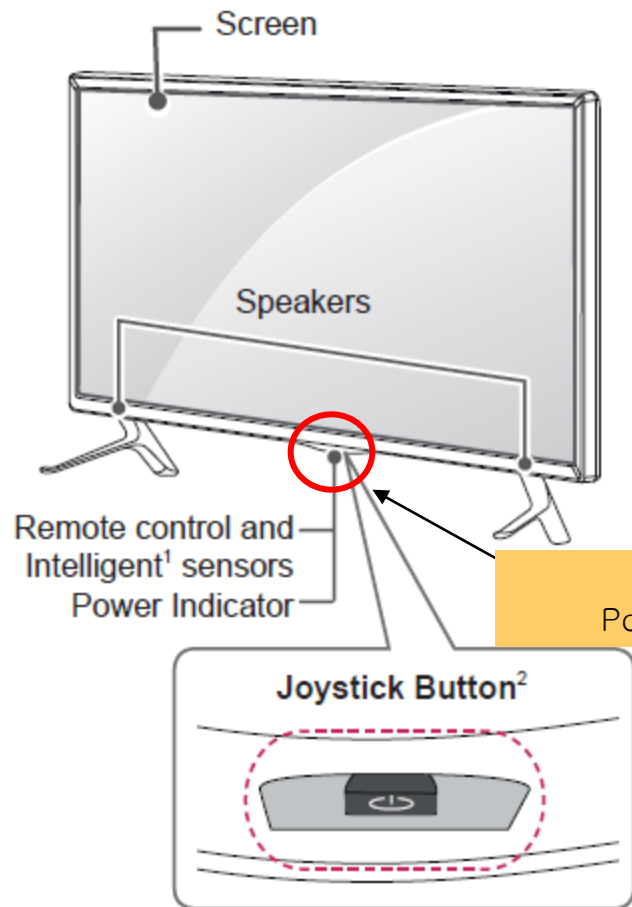

Front LED control :
Menu → Option →
Standby Light
→ ON/ Off

ST-BY condition: Red
Power ON condition: Turn Off

Standard Repair Process Detail Technical Manual

LCD TV	Error symptom	B. Power error _No power	Established date	2013. 12 .06	
	Content	Check power input voltage and ST-BY 3.5V	Revised date		A18



Check the 3.5V(3, 5, 6)

18 Pin (Power Board ↔ Main Board)			
1	Power on	2	DRV-ON
3	3.5V	4	P-DIM
5	3.5V	6	3.5V
7	GND	8	N.C
9	24V	10	24V
11	GND	12	GND
13	12V	14	12V
15	12V	16	N.C
17	GND	18	GND

Standard Repair Process Detail Technical Manual

LCD TV	Error symptom	B. Power error _No power	Established date	2013. 12 .06	
	Content	Checking method when power is ON	Revised date		A19

Check "power on" pin is high



18 Pin (Power Board ↔ Main Board)			
1	Power on	2	DRV-ON
3	3.5V	4	P-DIM
5	3.5V	6	3.5V
7	GND	8	N.C
9	24V	10	24V
11	GND	12	GND
13	12V	14	12V
15	12V	16	N.C
17	GND	18	GND

Standard Repair Process Detail Technical Manual

LCD TV	Error symptom	B. Power error _Off when on, off whiling viewing	Established date	2013. 12 .06	
	Content	POWER OFF MODE checking method	Revised date		A22

<ALL MODELS>

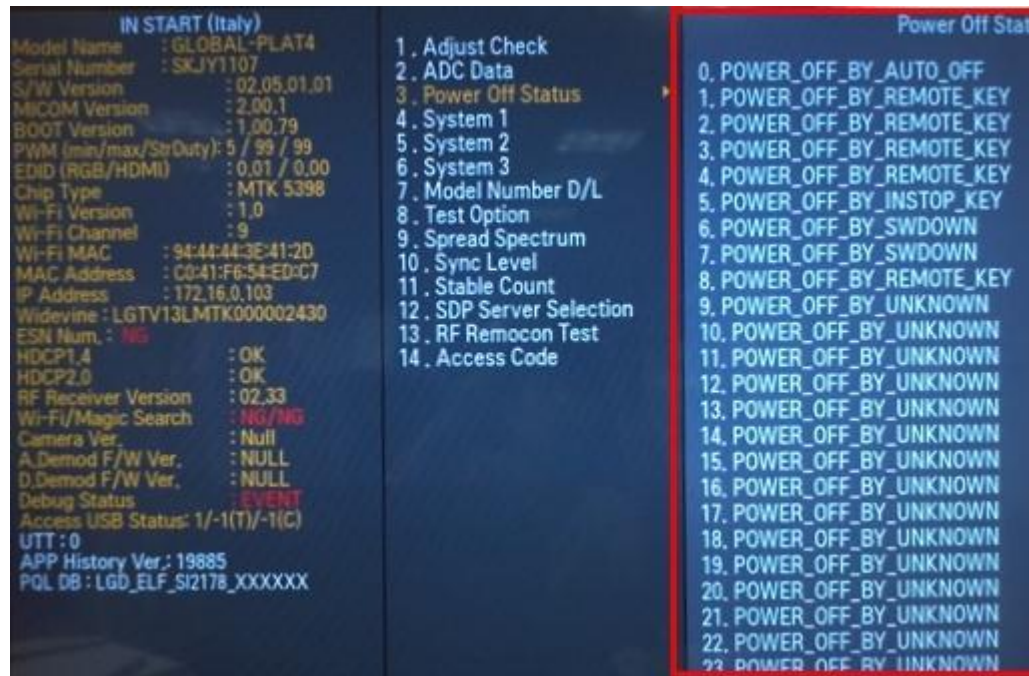

Entry method

1. Press the IN-START button of the remote controller for adjustment
2. Check the entry into adjustment item 3

Standard Repair Process Detail Technical Manual

LCD TV	Error symptom	C. Audio error_No audio/Normal video	Established date	2013. 12 .06	
	Content	Checking method in menu when there is no audio	Revised date		A24

<ALL MODELS>



Checking method

1. Press the MENU button on the remote controller
2. Select the SOUND function of the Menu
3. Change TV Sound Out to TV Speaker

Standard Repair Process Detail Technical Manual

LCD TV	Error symptom	C. Audio error_No audio/Normal video	Established date	2013. 12 .06	
	Content	Voltage and speaker checking method when there is no audio	Revised date		A25

<ALL MODELS>



18 Pin (Power Board ↔ Main Board)			
1	Power on	2	DRV-ON
3	3.5V	4	P-DIM
5	3.5V	6	3.5V
7	GND	8	N.C
9	24V	10	24V
11	GND	12	GND
13	12V	14	12V
15	12V	16	N.C
17	GND	18	GND

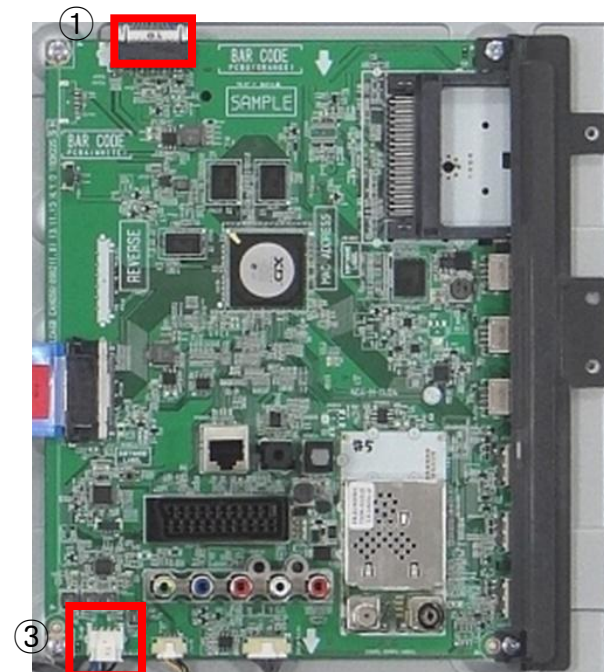

Checking order when there is no audio

① Check the contact condition of or 24V connector of Main Board

② Measure the 24V input voltage supplied from Power Board
(If there is no input voltage, remove and check the connector)

③ Connect the tester RX1 to the speaker terminal and if you hear the Chik Chik sound when you touch the GND and output terminal, the speaker is normal.

Standard Repair Process Detail Technical Manual

LCD TV	Error symptom	D. Function error_ No response in remote controller, key error	Established date	2013. 12 .06	
	Content	Remote controller operation checking method	Revised date		A27

<ALL MODELS>

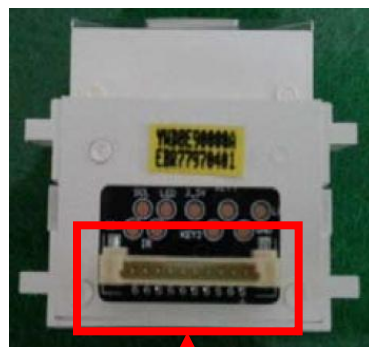

①

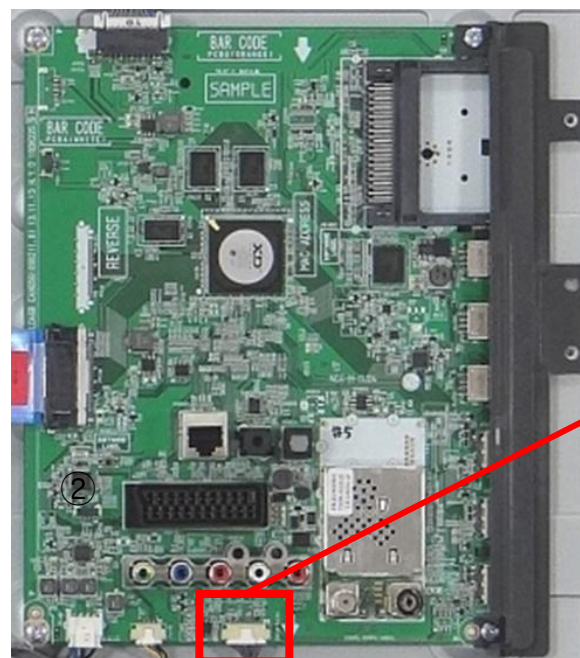

③

④

P4101	
1	GND
2	KEY1
3	KEY2
4	3_5V_ST
5	GND
6	LED
7	IR
8	GND
9	SCL
10	SDA

Checking order

- 1, 2. Check IR cable condition between IR & Main board.
3. Check the st-by 3.5V on the terminal 4.
4. When checking the Pre-Amp when the power is in ON condition, it is normal when the Analog Tester needle moves slowly, and defective when it does not move at all.