

# 10A. 30V Laboratory PSU

- \* Output voltage variable from 0 to +30V (Fine adjustment over 1V)
- \* Variable current limit from 0 to 10A
- \* LED current limit indicator
- \* Output short circuit protected Maximum 0.5V RMS

**T**his extremely flexible laboratory power supply unit (PSU) is capable of sourcing well-regulated DC voltages of up to 30V at currents of up to 8A continuous, 10A peak. As a result, there is a wide range of potential applications for the hobbyist, service department and educational institutions. For example, it is ideal for the testing of prototypes; in addition to the sheer power output available, there is a current-limiting function—ideal for trying out your more delicate circuits. This function, and the robust nature of this unit, makes it an ideal choice for servicing DC equipment (e.g., portable audio and video equipment) and for college workbenches. In addition, this piece of equipment is ideal for the running of CB and amateur radio equipment

## Applications

- \* Laboratories and test benches
- \* Powering mobile radio equipment
- \* Precision charging of batteries

and even the charging of batteries; lead-acid packs in 'constant voltage' mode, and Ni-Cad cells in 'constant current' mode.

## Circuit Description

### 1. Control PCB

(Refer to circuit diagram of Figure 1).

IC2 & 3 are p.A723 voltage/current

regulators. IC2 is used to set the out-put voltage; R6 providing feedback to compensate for the voltage drop across T2, R16, T3 and R31. A fraction of the output voltage determined by R5 and R23 is supplied to IC2 as feedback. IC3 is responsible for current-limiting; its operation is very interesting. A user-set reference voltage (the 'current limit') is derived from the IC3's on-chip reference via RV1/2/3, R18, R27 and R28. This is compared to the voltage developed across R37 to R40 (which are situated between output ground and the reference ground); if it exceeds the user-set reference, then the error voltage produced by IC3 will be sufficient to forward-bias the LED, in doing so it will turn on the current-limiting transistor integral to voltage regulator IC2.

T2 is the control transistor for T3, a Darlington device, which provides plenty of drive current for the output pass transistors T4 to T8, which are fed with the smoothed DC output from the bridge rectifier and reservoir capacitors. Note that the main power transformer is a very beefy (300VA, 15-0-15V) toroidal type. R41 to R45 are required to allow for the variation in current gain among the transistors; these items are not matched. D3 is present to protect the power supply from any reverse-polarity voltages that may accidentally be applied to its output terminals.

IC1 is a 741 Op-amp configured as a comparator; it switches in the second winding of the toroidal trans-former, via T1 and RY1, when the output voltage rises above 12V; this voltage is determined by R1/R2. The positive voltage sense, positive current sense, and common outputs for the display PCB.

## **TESTING**

Place a 220V/25W or 40W lamp over the fuse holder of the power supply. The fuse must NOT be mounted yet. - Turn the trimming potentiometers RV1 and RV2 (on the base board) in the intermediate position. - Turn the trimming potentiometers of the digital readouts (METER ADJUST) completely to the right. - Turn the current (current potentiometer) on maximum. - Connect the mains with the mains plug and switch the power supply on. If everything functions properly, the lamp should light for only a second or not at all; if the lamp keeps lighting however, then the power supply should be switched off and the wiring checked. - The digital readout should now light up. - Connect a voltmeter to the output terminals and check whether the output voltage is adjustable between 0 and 30V. Around approximately 12V one should hear the relay excitation. - Switch off the power supply (remove mains plug as well). - Connect the right transistor board connections E, B and C with the corresponding connections of the base board by means of pieces of white, blue and red wire. (do not forget the cable shoes) (see figure 7.0). - Make an interconnection from one transistor board to the other. (see figure 7.0). - Switch the power supply back on (the lamp can now light up as well) and check whether the output voltage is adjustable between 0 and 30V. - Remove the mains voltage and also remove the lamp connections of the fuse holder. Mount a 4A inert fuse in the fuse holder. - The line voltage of the fan can now be connected.

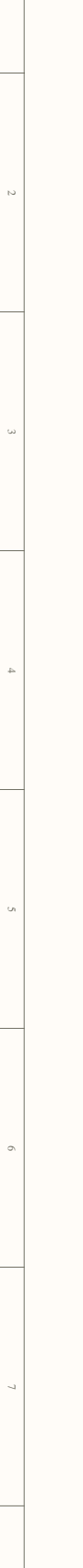
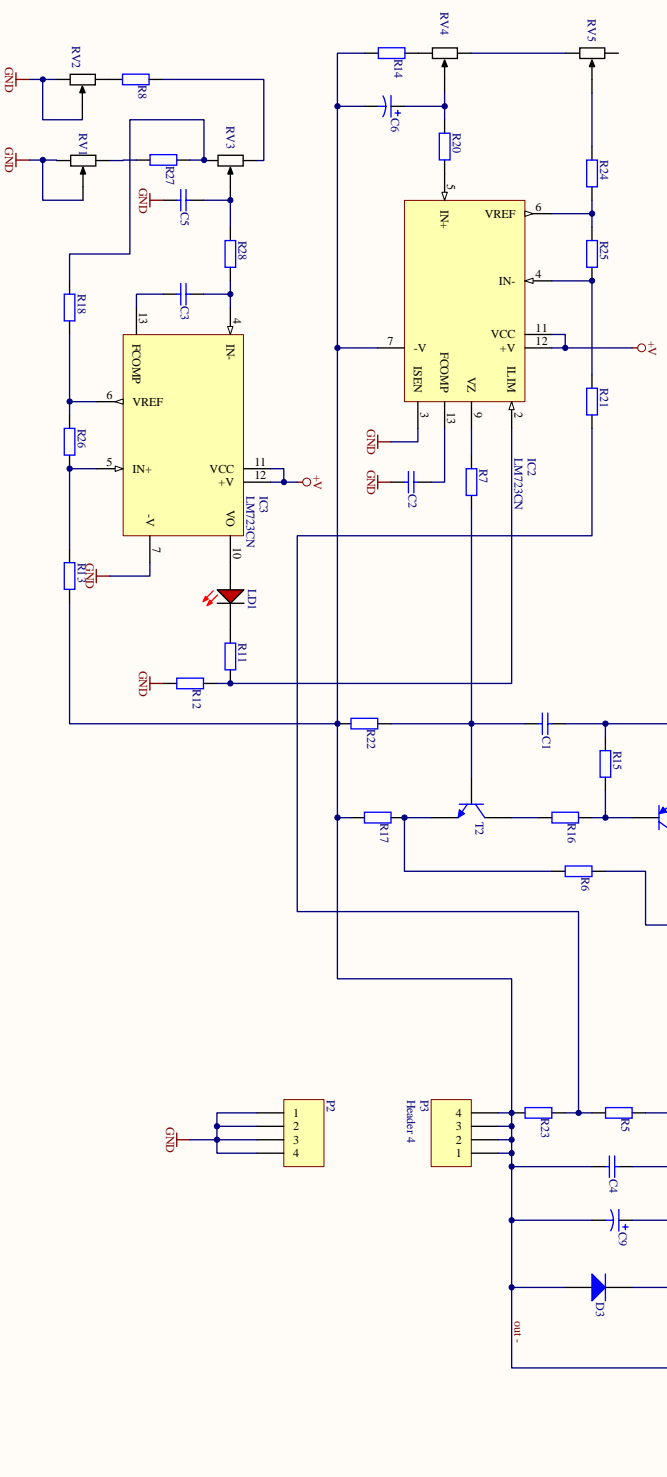
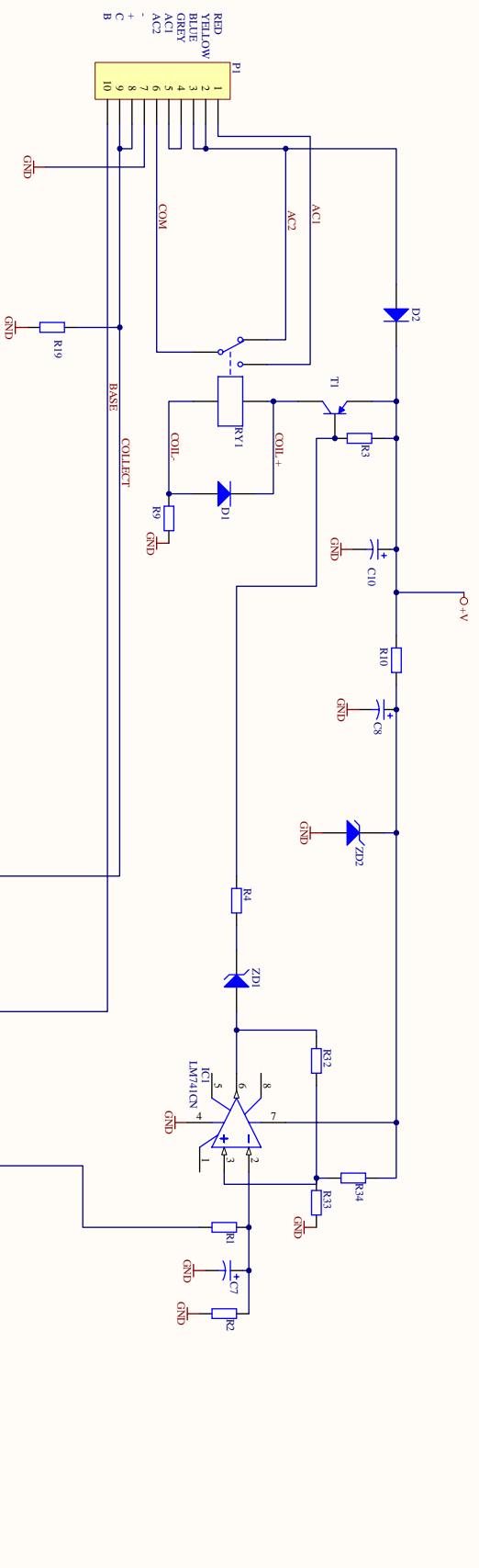

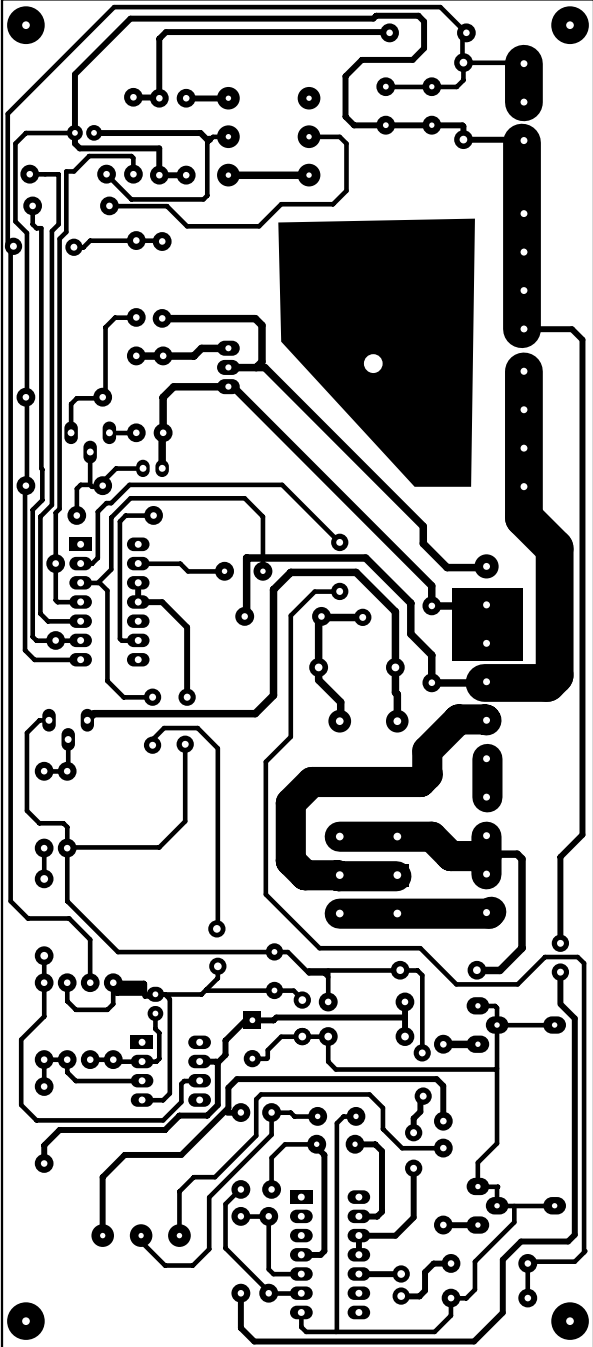

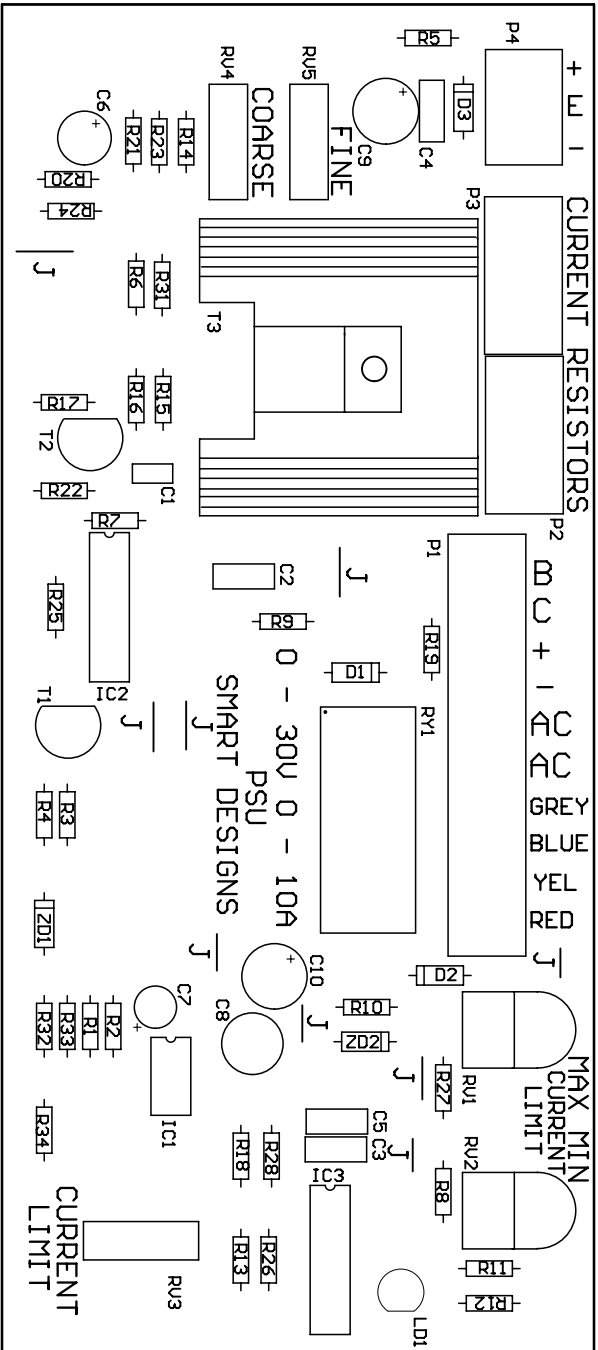

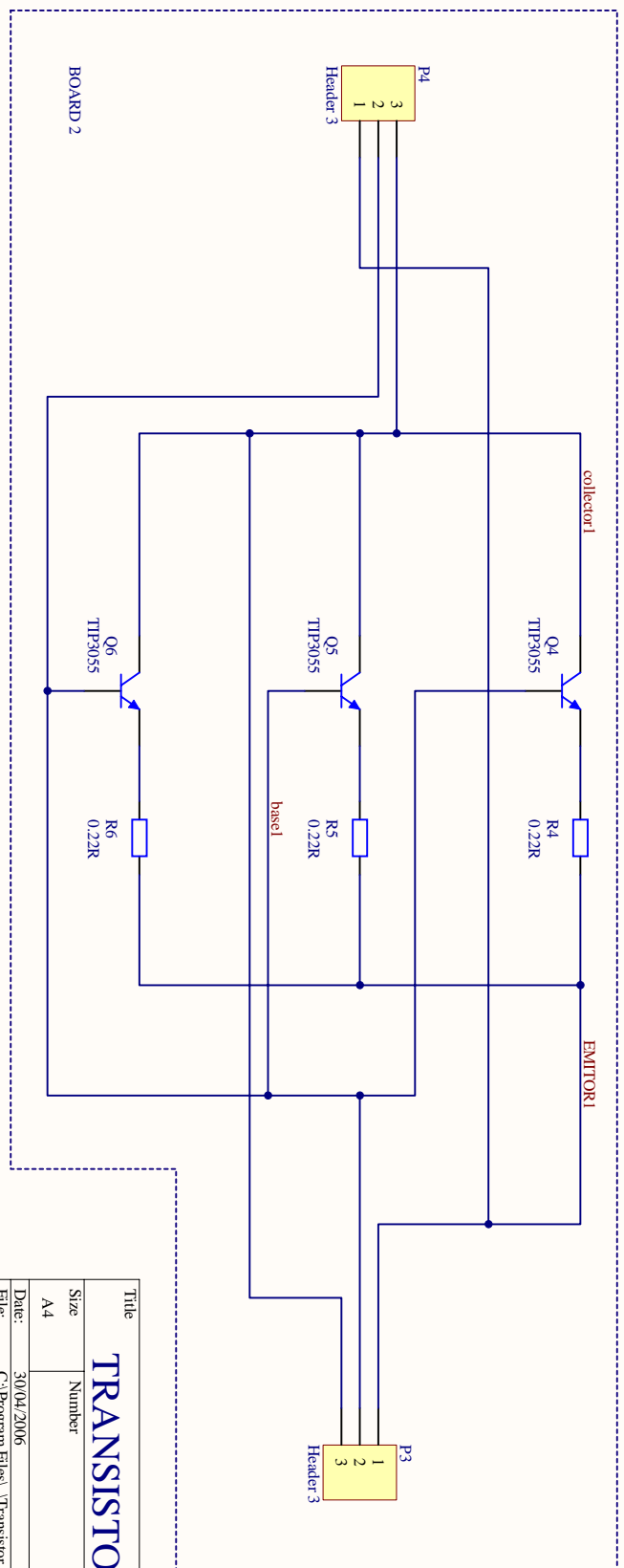
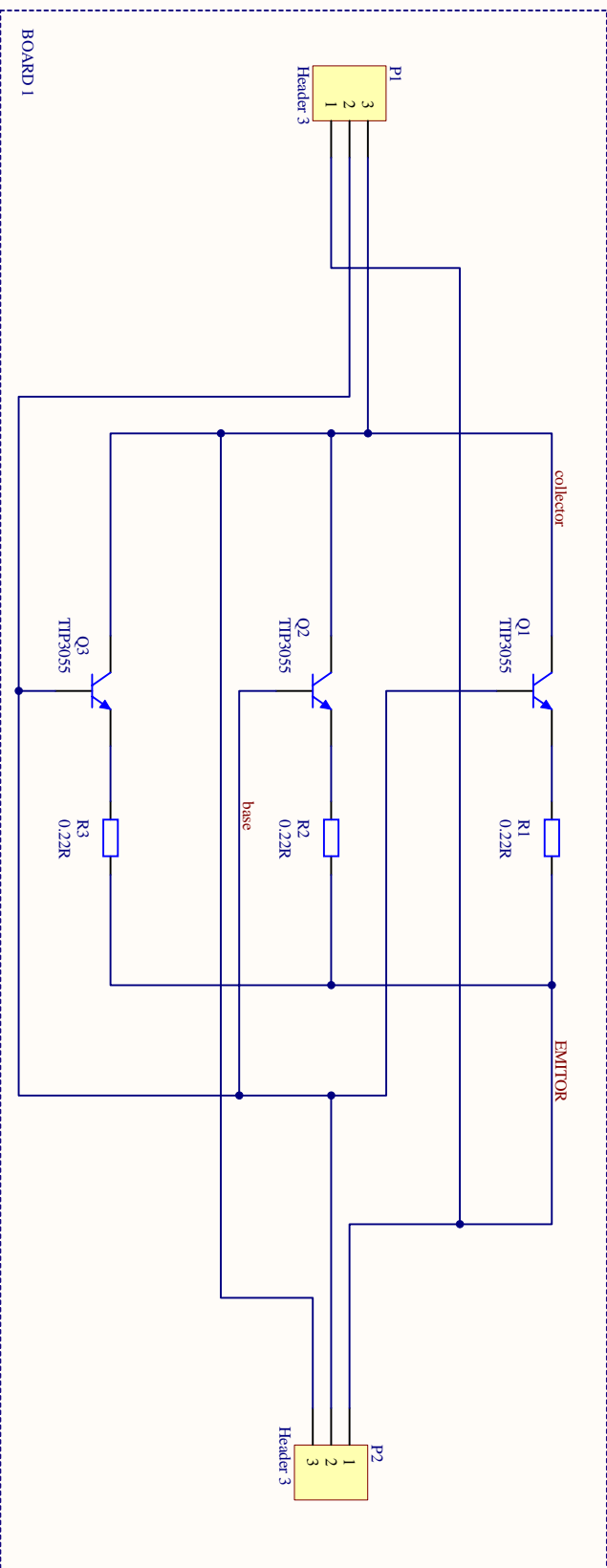

# TRANSISTOR PASS BOARD

Title		Revision	
Size	Number	Sheet	of
A4			
Date:	30/04/2006	Drawn By:	
File:	C:\Program Files\... \Transistor board1.SchP		

1

2

3

4

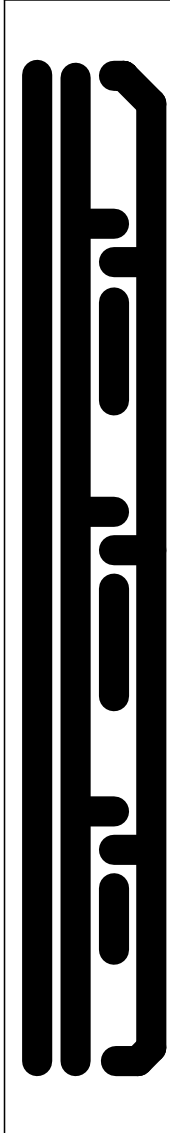

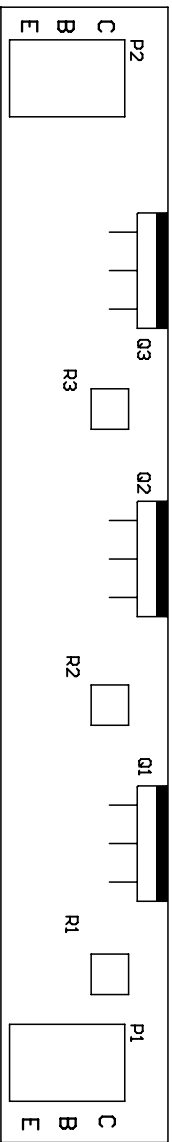
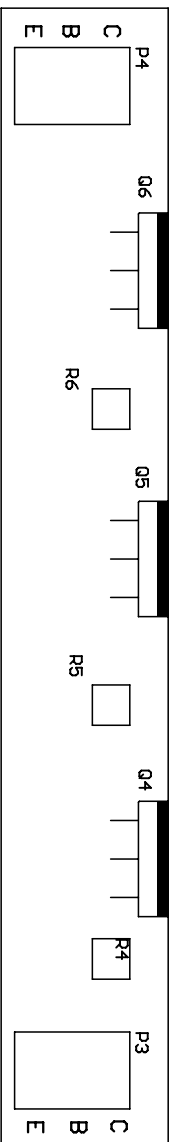



## 10A 30V LABORATORY PSU PARTS LIST

### 1. CONTROL PCB RESISTORS

R1	6k8	1
R2	8k2	1
R3-8	4k77	6
R9	39R	1
R10	180R	1
R11-12	220R	2
R13,14	2k2	2
R15,16	2k7	2
R17,18	820R	2
R19-22	22k	3
R23,24	1k2	2
R25	100k	1
R26	15k	1
R27	100R	1
R28,29	1k	2
R30	220k	1
R31	18R	1
R32	270k	1
R33	12k	1
R34	27k	1
RV1	100R Vertical Preset	1
RV2	47k Vertical Preset	1
RV3	4k7 Pot Log	1
RV4	10k Pot Lin	1
RV5	1k Pot Lin	1

### CAPACITORS

C1	150pF Ceramic	1
C2	33nF Metallised Polyester Film	1
C3	68nF Metallised Polyester Film	1
C4	100nF Ceramic	1
C5	1uF Metallised Polyester Film	1
C6,C7	10UF 35V Electrolytic	2
C8,C9	100pF 35V Electrolytic	2
C10	4700UF 35V Electrolytic	1

### SEMICONDUCTORS

IC1	741	1
IC2,IC3	LM723	1
T1	BC557B (or equiv.)	1
T2	BC547B (or equiv.)	1
T3	BD646 (TIP41)	1
D1-D3	1N4001 Series Diode	3
ZD1	10V 500mW zener	1
ZD2	18V 1.3W zener	1
LD1	Red LED 3mm	1

### MISCELLANEOUS

RY1	Single Pole Changeover Relay	1
P1	10-way PCB-mounting Terminal Block	5
P2	3-way PCB-mounting Terminal Block	1
	14-pin DIL socket	2
	8-pin DIL socket	1
		1
	Heatsink for BD646	1

**PASS TRANSISTOR PCBs****RESISTORS**

R1-R6 0.22R 5W 6

**SEMICONDUCTORS**

TIP3055 6

**MISCELLANEOUS**

3 WAY PCB Terminal block 4

PCB Pin 15

Mica Washer 6

Insulating Bush 6

**HARDWARE MISCELLANEOUS**

B1 Bridge Rectifier 1

C11,C12 4700UF 63V Electrolytic Capacitor 2

SW12 Pole Mains Rocker Switch 1

F1 20mm Panel-mounting Fuseholder 1

20mm Fuse 4A 1

Chassis-mounting Europlug 1

Europlug Lead 1

# Main PCB and Pass Transistor PCB Wiring

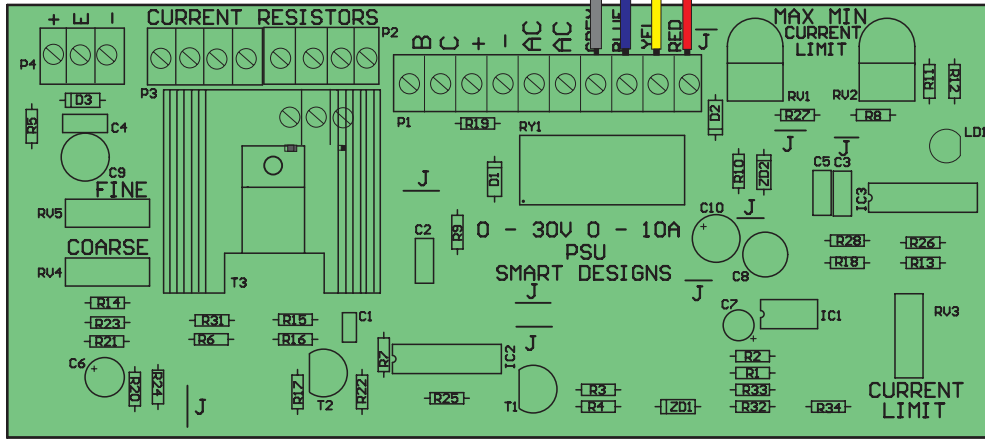
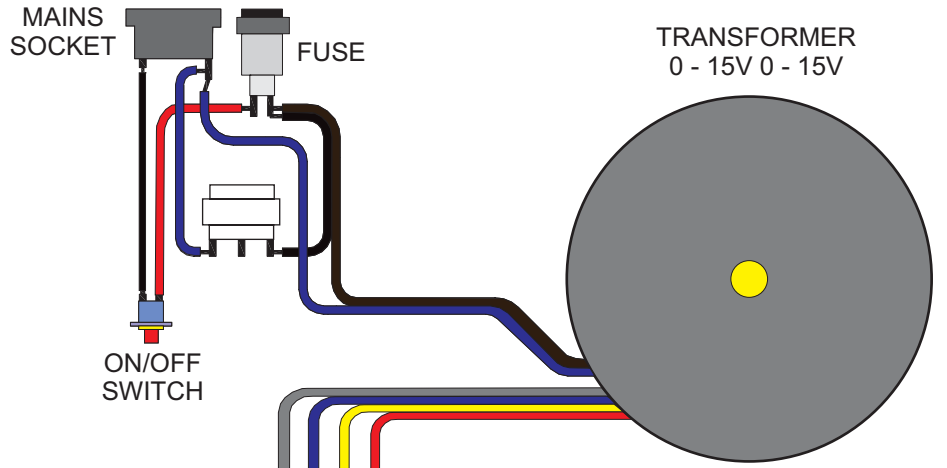

MAIN PCB

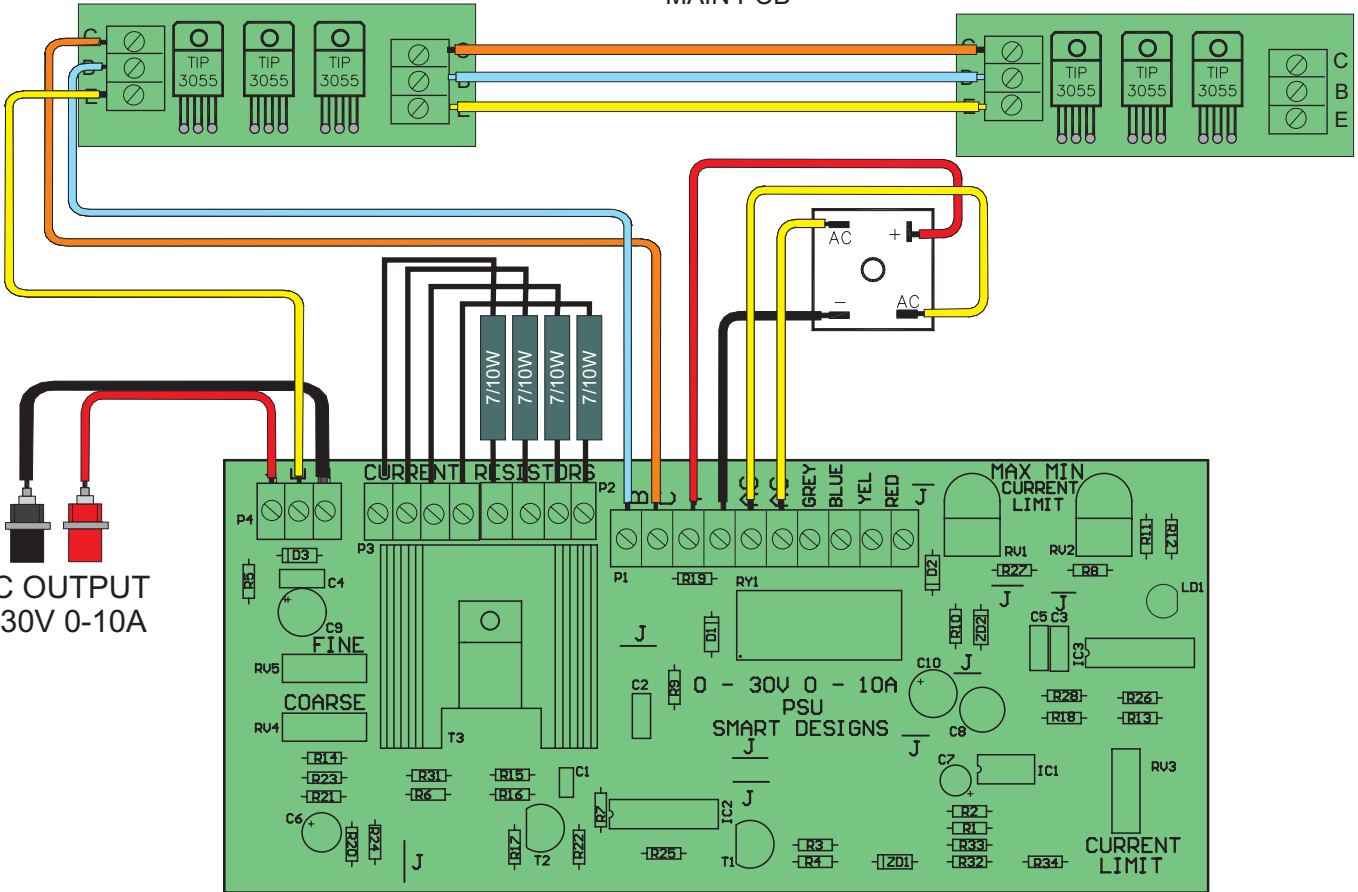

# Wiring the Capacitors

