

STEREO RECEIVER RX-397

SERVICE MANUAL

IMPORTANT NOTICE

This manual has been provided for the use of authorized YAMAHA Retailers and their service personnel. It has been assumed that basic service procedures inherent to the industry, and more specifically YAMAHA Products, are already known and understood by the users, and have therefore not been restated.

WARNING: Failure to follow appropriate service and safety procedures when servicing this product may result in personal injury, destruction of expensive components, and failure of the product to perform as specified. For these reasons, we advise all YAMAHA product owners that any service required should be performed by an authorized YAMAHA Retailer or the appointed service representative.

IMPORTANT: The presentation or sale of this manual to any individual or firm does not constitute authorization, certification or recognition of any applicable technical capabilities, or establish a principle-agent relationship of any form.

The data provided is believed to be accurate and applicable to the unit(s) indicated on the cover. The research, engineering, and service departments of YAMAHA are continually striving to improve YAMAHA products. Modifications are, therefore, inevitable and specifications are subject to change without notice or obligation to retrofit. Should any discrepancy appear to exist, please contact the distributor's Service Division.

WARNING: Static discharges can destroy expensive components. Discharge any static electricity your body may have accumulated by grounding yourself to the ground buss in the unit (heavy gauge black wires connect to this buss).

IMPORTANT: Turn the unit OFF during disassembly and part replacement. Recheck all work before you apply power to the unit.

■ CONTENTS

TO SERVICE PERSONNEL	2	AMP ADJUSTMENT	16
IMPEDANCE SELECTOR	3	IC DATA	17-18
FRONT PANEL	3	DISPLAY DATA	19
REAR PANELS	4-5	PIN CONNECTION DIAGRAM	20
REMOTE CONTROL PANEL	5	PRINTED CIRCUIT BOARD	21-27
SPECIFICATIONS	6-7	BLOCK DIAGRAM	28
INTERNAL VIEW	7	SCHEMATIC DIAGRAM	29-31
DISASSEMBLY PROCEDURES	8	REMOTE CONTROL RAX16	33
SELF DIAGNOSIS FUNCTION	9-15	PARTS LIST	34-42



このサービスマニュアルは、エコマーク認定の再生紙を使用しています。
This Service Manual uses recycled paper.

100978

© 2005 YAMAHA CORPORATION. All rights reserved.
This manual is copyrighted by YAMAHA and may not be copied or redistributed either in print or electronically without permission.



YAMAHA

YAMAHA CORPORATION
P.O.Box 1, Hamamatsu, Japan

ED01 '05.11

■ TO SERVICE PERSONNEL

- Critical Components Information**
Components having special characteristics are marked  and must be replaced with parts having specifications equal to those originally installed.
- Leakage Current Measurement (For 120V Models Only)**
When service has been completed, it is imperative to verify that all exposed conductive surfaces are properly insulated from supply circuits.
 - Meter impedance should be equivalent to 1500 ohms shunted by 0.15µF.

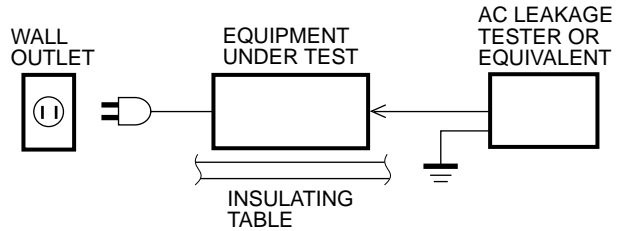

- Leakage current must not exceed 0.5mA.
- Be sure to test for leakage with the AC plug in both polarities.



“CAUTION”

“F251, F252 : FOR CONTINUED PROTECTION AGAINST RISK OF FIRE, REPLACE ONLY WITH SAME TYPE 5A, 125V FUSE.”

CAUTION

F251, F252 : REPLACE WITH SAME TYPE 5A, 125V FUSE.

ATTENTION

F251, F252 : UTILISER UN FUSIBLE DE RECHANGE DE MEME TYPE DE 5A, 125V.

WARNING: CHEMICAL CONTENT NOTICE!

The solder used in the production of this product contains LEAD. In addition, other electrical/electronic and/or plastic (where applicable) components may also contain traces of chemicals found by the California Health and Welfare Agency (and possibly other entities) to cause cancer and/or birth defects or other reproductive harm.

DO NOT PLACE SOLDER, ELECTRICAL/ELECTRONIC OR PLASTIC COMPONENTS IN YOUR MOUTH FOR ANY REASON WHATSOEVER!

Avoid prolonged, unprotected contact between solder and your skin! When soldering, do not inhale solder fumes or expose eyes to solder/flux vapor!

If you come in contact with solder or components located inside the enclosure of this product, wash your hands before handling food.

About Lead Free Solder

The P.C.B.s installed in this unit are soldered using the following solder.

	SIDE A	SIDE B
FUNCTION P.C.B.	-	Lead Free Solder
OPERATION P.C.B.	-	Lead Free Solder
MAIN P.C.B.	-	Lead Free Solder

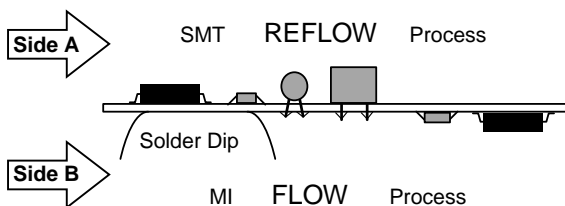

Among some types of lead free solder currently available, it is recommended to use one of the following types for the repair work.

- Sn + Ag + Cu (tin + silver + copper)
- Sn + Cu (tin + copper)
- Sn + Zn + Bi (tin + zinc + bismuth)

Caution:

- As the melting point temperature of the lead free solder is about 30°C to 40°C (50°F to 70°F) higher than that of the lead solder, be sure to use a soldering iron suitable to each solder.
- If lead solder must be used, be sure to remove lead free solder from each terminal section of the parts to be replaced and from the area around it completely before soldering, or make sure that the lead free solder and lead solder melt together fully.

■ IMPEDANCE SELECTOR

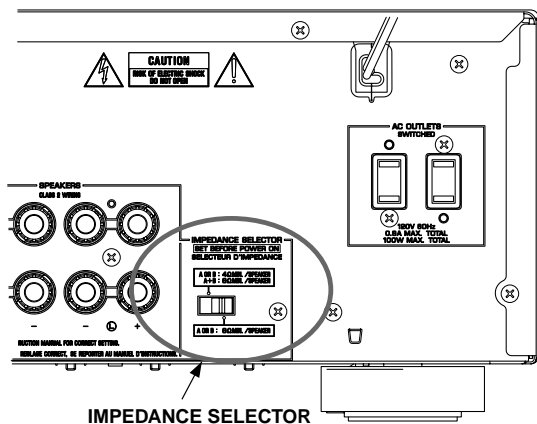

WARNING:
Do not change the setting of the IMPEDANCE SELECTOR switch when the unit power is switched on, as doing so may damage the unit.

■ FRONT PANEL

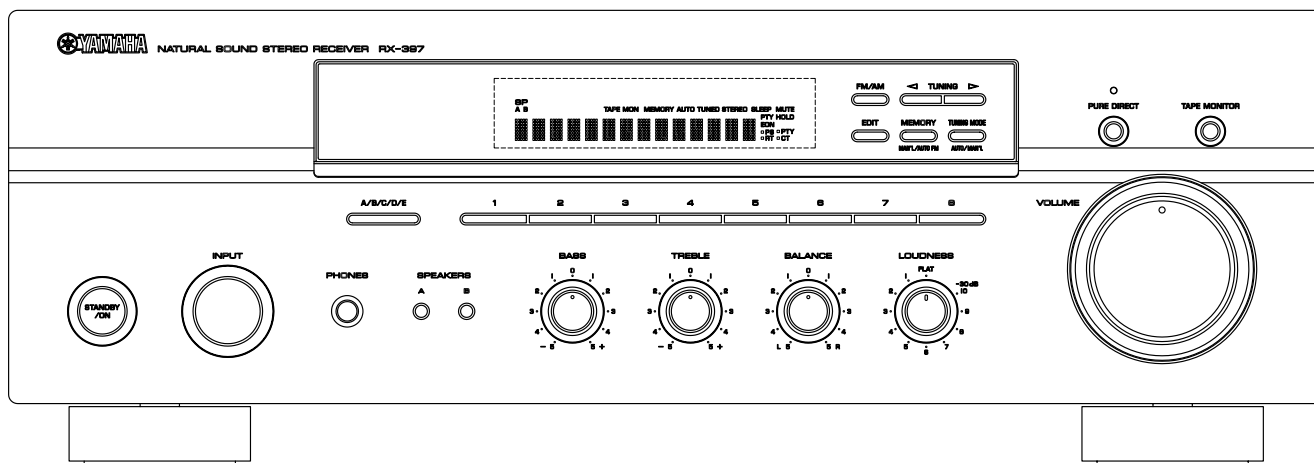

RX-397

REAR PANELS

U, C models

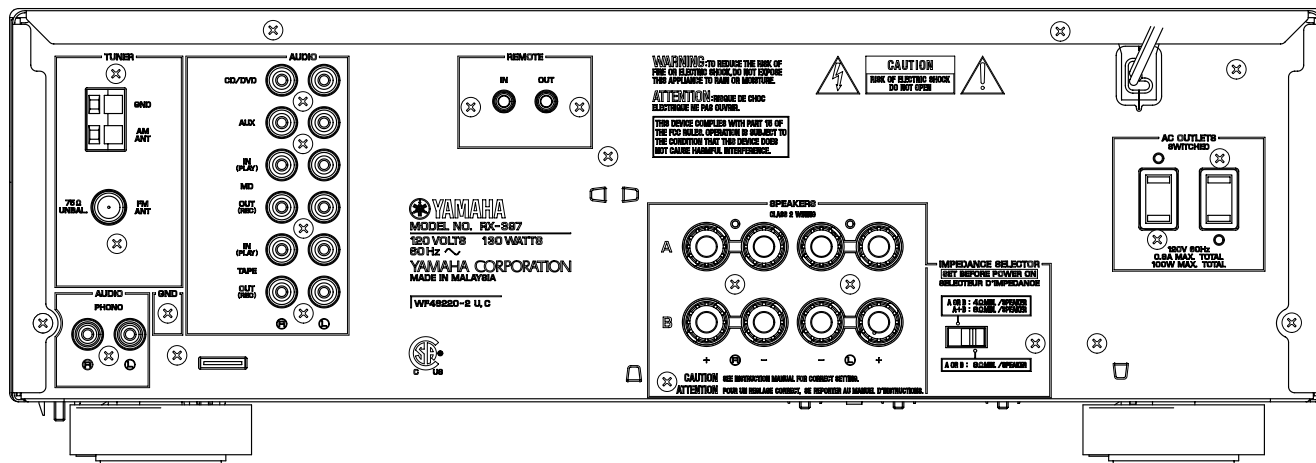

R model

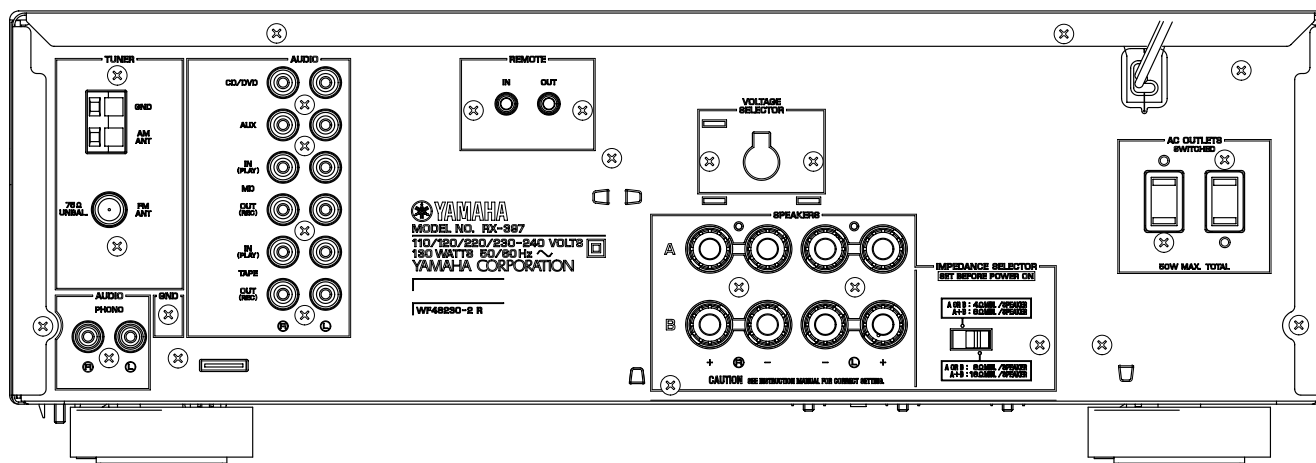

A model

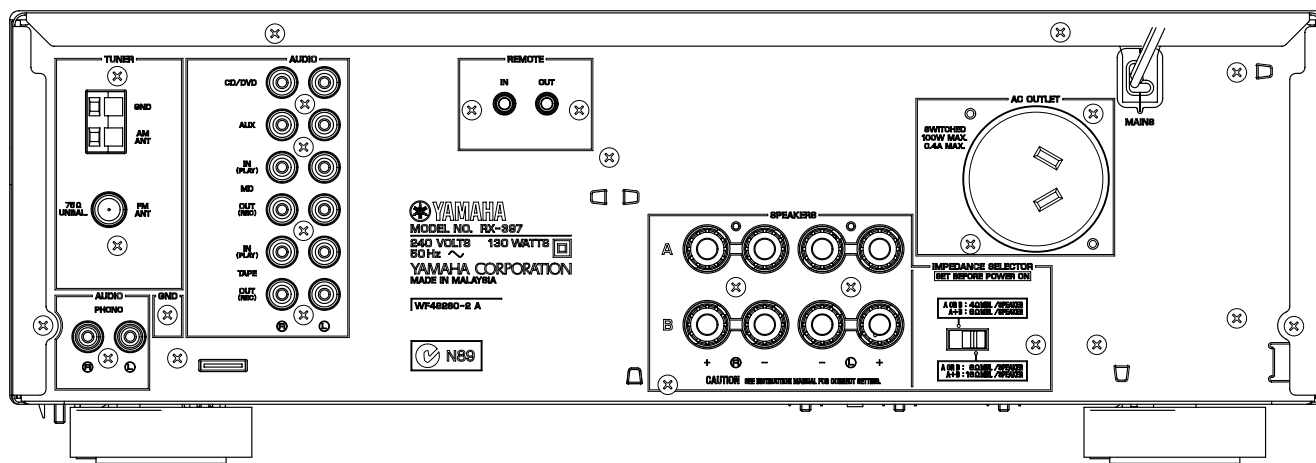

RX-397

▼ G, E models

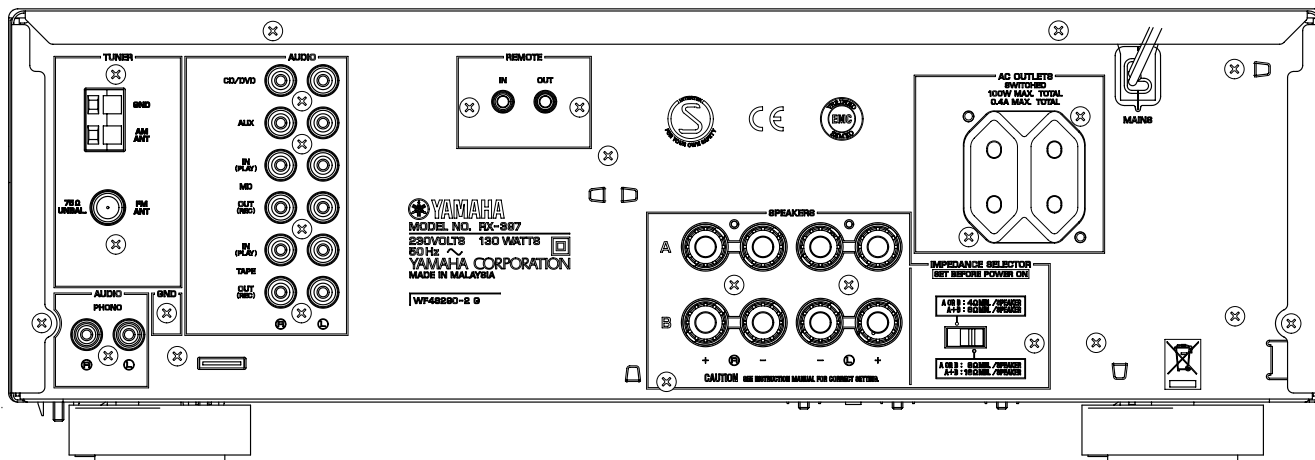

▼ L model

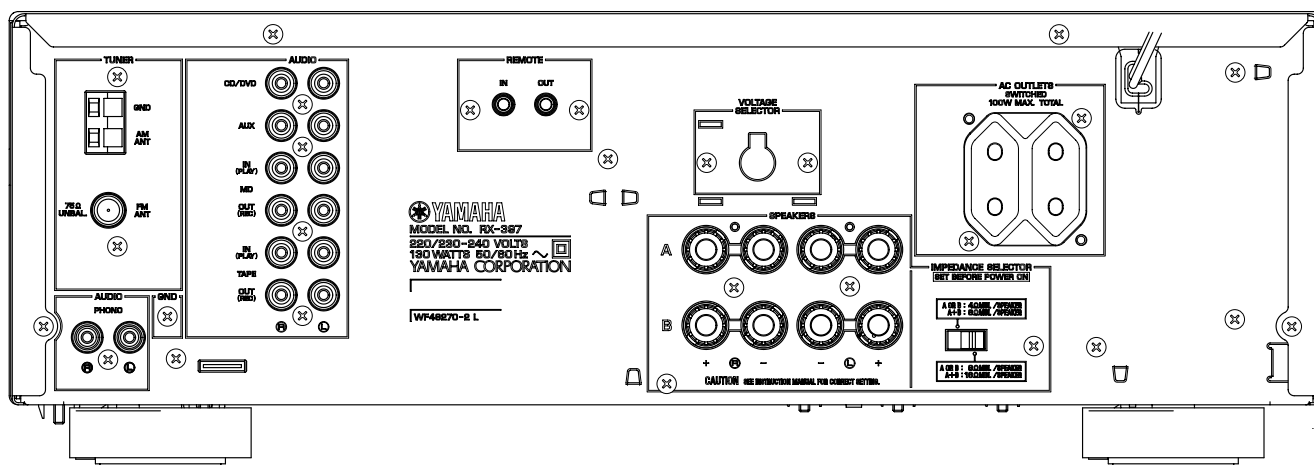

■ REMOTE CONTROL PANEL

▼ RAX16

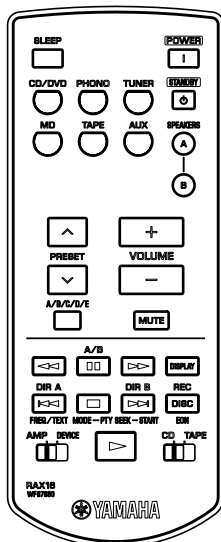

SPECIFICATIONS

AUDIO SECTION

Minimum RMS Output Power (Power Amp. Section)

L/R, 20 Hz to 20 kHz, 0.04% THD, 8 ohms 50 W + 50 W

Dynamic Power Per Channel (IHF)

8/6/4/2 ohms 70/77/89/100 W

Maximum Power Per Channel (G, E models)

1 kHz, 0.7 % THD, 4 ohms 55 W

IEC Power (G, E models)

1 kHz, 0.04% THD, 8 ohms 52 W

Maximum Power (EIAJ) (R, L models)

1 kHz, 10% THD, 8 ohms 85 W

Power Band Width

L/R, 0.08% THD, 22.5 W, 8 ohms 10 Hz to 50 kHz

Damping Factor

20 Hz to 20 kHz, SPEAKER-A, 8 ohms 150 or more

Input Sensitivity/Input Impedance

PHONO MM 2.5 mV/47 k-ohms

CD, etc. 150 mV/47 k-ohms

Maximum Input Signal

PHONO MM, 1kHz, 0.04 % THD 115 mV

CD, etc., 1kHz, 0.04 % THD 2.2 V

Output Level/Output Impedance

REC OUT 150 mV/1.2 k-ohms

Headphone Jack Rated Output/Output Impedance

CD, etc. 1 kHz, 150 mV, 8 ohms, 0.04% THD 0.47 V/330 ohms

Frequency Response

CD, etc. 20 Hz to 20 kHz 0 ± 0.5 dB

CD, etc. PURE DIRECT ON, 10 Hz to 100 kHz 0 ± 1.0 dB

RIAA Equalization Deviation

PHONO MM 0 ± 0.5 dB

Total Harmonic Distortion (20 Hz to 20 kHz)

PHONO MM to REC OUT (3 V) 0.02 % or less

CD, etc. to SP OUT (35 W/8 ohms) 0.02 % or less

Signal to Noise Ratio (IHF-A Network)

PHONO MM (Input shorted, 5 mV) 82 dB or more

CD, etc. (Input shorted, 150mV) 108 dB or more

Residual Noise (IHF-A Network)

PURE DIRECT ON 100 µV

Channel Separation

CD, etc. (Input 5.1 k-ohms shorted)

1 kHz 65 dB or more

10 kHz 50 dB or more

Tone Control Characteristics

BASS Boost/Cut (50 Hz) +10 dB/-10 dB

Turnover Frequency 350 Hz

TREBLE Boost/Cut (20 kHz) +10 dB/-10 dB

Turnover Frequency 3.5 kHz

Continuous Loudness Control

Attenuation (1 kHz) -30 dB

Gain Tracking Error

0 to -60 dB 2 dB or less

FM SECTION

Tuning Range

U, C models 87.5 to 107.9 MHz

R, L models 87.5 to 108.0/87.50 to 108.00 MHz

A, G, E models 87.50 to 108.00 MHz

50 dB Quieting Sensitivity (IHF)

1 kHz 100% MOD.

Mono 2.0 µV (17.3 dBf)

Stereo 25 µV (39.2 dBf)

Usable Sensitivity (IHF)

Mono 1.0 µV (11.2 dBf)

Selectivity

at 400 kHz 70 dB

Signal to Noise Ratio (IHF)

Mono 76 dB

Stereo 70 dB

Harmonic Distortion (1 kHz)

Mono 0.2 %

Stereo 0.3 %

Stereo Separation (1 kHz)

..... 45 dB

Frequency Response

20 Hz to 15 kHz +0.5/-2.0 dB

Antenna Input

..... 75 ohms unbalanced

AM SECTION

Tuning Range

U, C models 530 to 1710 kHz

R, L models 530 to 1710/531 to 1611 kHz

A, G, E models 531 to 1611 kHz

Usable Sensitivity

..... 300 µV/m

Antenna

..... Loop antenna

GENERAL

Power Supply

U, C models AC 120 V, 60 Hz

R model AC 110/120/220/230-240 V, 50/60 Hz

A model AC 240 V, 50 Hz

G, E models AC 230 V, 50 Hz

L model AC 220/230-240 V, 50/60 Hz

Power Consumption (reference)

..... 130 W

Standby Power Consumption

..... 0.1 W

Maximum Power Consumption (R model)

1 kHz, 8 ohms, 10% THD 300 W

AC Outlet

2 Switched Outlet

R model 50 W Max. total

U, C, G, E, L models 100 W Max. total

1 Switched Outlet

A models 100 W Max.

Dimensions (W x H x D)

..... 435 x 151 x 308 mm

(17-1/8" x 5-15/16" x 12-1/8")

Weight

..... 7.4 kg (16 lbs 5 oz)

Finish

..... Black Color (U, C, R, A, G, E, L models)

..... Titanium Color (G, E, L models)

Accessories

..... Remote Control x 1

..... Battery (AAA, R03, UM-4) x 2

..... Indoor FM Antenna x 1

..... AM Loop Antenna x 1

* Specifications subject to change without notice.

U *USA model*

C *Canadian model*

R *General model*

A *Australian model*

G *European model*

E *South European model*

L *Singapore model*

DIMENSIONS

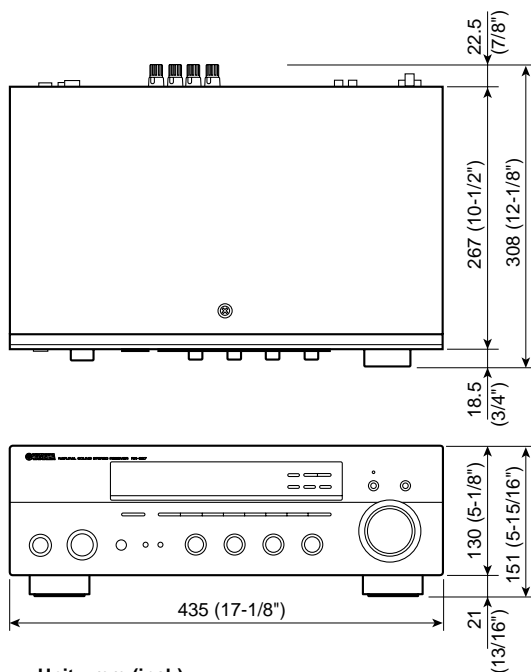

Unit : mm (inch)

INTERNAL VIEW

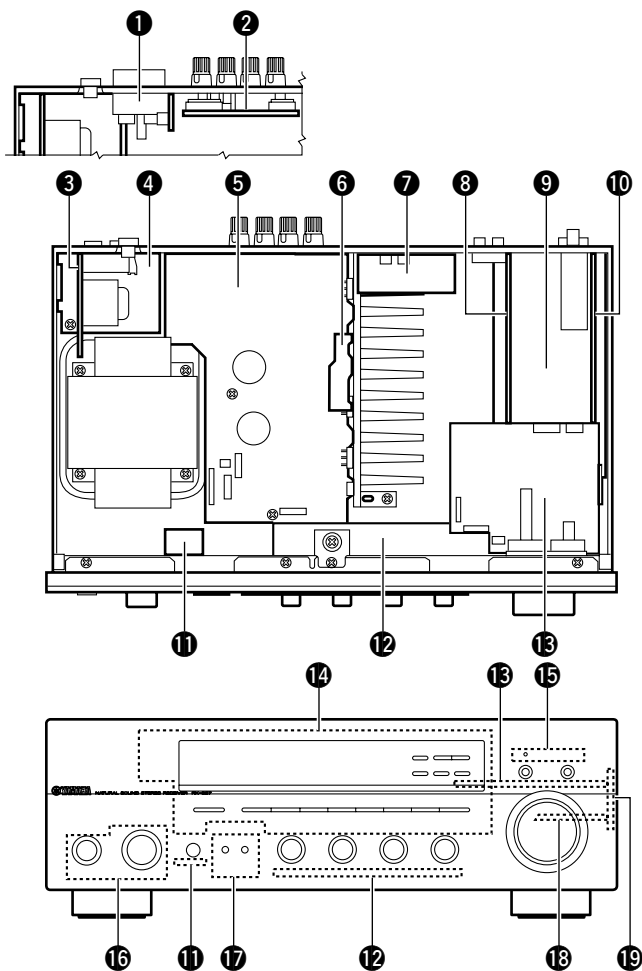

- ❶ OPERATION (12) P.C.B. (A, G, E, L models)
- ❷ MAIN (4) P.C.B. (R, L models)
- ❸ MAIN (2) P.C.B.
- ❹ MAIN (3) P.C.B.
- ❺ MAIN (1) P.C.B.
- ❻ MAIN (5) P.C.B.
- ❼ FUNCTION (4) P.C.B.
- ❽ FUNCTION (1) P.C.B.
- ❾ FUNCTION (2) P.C.B.
- ❿ OPERATION (13) P.C.B.
- ⓫ OPERATION (10) P.C.B.
- ⓬ OPERATION (3) P.C.B.
- ⓭ OPERATION (2) P.C.B.
- ⓮ OPERATION (1) P.C.B.
- ⓯ OPERATION (8) P.C.B.
- ⓰ OPERATION (5) P.C.B.
- ⓱ OPERATION (7) P.C.B.
- ⓲ OPERATION (4) P.C.B.
- ⓳ OPERATION (9) P.C.B.

■ DISASSEMBLY PROCEDURES

- Remove parts in disassembly order as numbered.
- Disconnect the power cable from the AC outlet.

1. Removal of Top Cover

- Remove 4 screws (①), 1 screw (②) and 4 screws (③). (Fig. 1)
- Slide the Top Cover rearward to remove it. (Fig. 1)

2. Removal of Front Panel Unit

- Remove 5 knobs (INPUT, BASS, TREBLE, BALANCE and LOUDNESS).
- Remove 1 screw (④) and then remove the Support Top. (Fig. 1)
- Remove 7 screws (⑤) and then remove the Front Panel Unit. (Fig. 1)

3. Removal of Plate Side

Remove 2 push rivets (⑥) and then remove the Plate Side L/R. (Fig. 1)

4. Removal of Sub Chassis Unit

- Remove 2 screws (⑦) and then slide the Sub Chassis Unit forward. (Fig. 1)
- Loosen the harness fixture fixing the cable.
- Remove connectors CB103, CB401, CB404, CB606 and CB611 and then remove the Sub Chassis Unit. (Fig. 1)

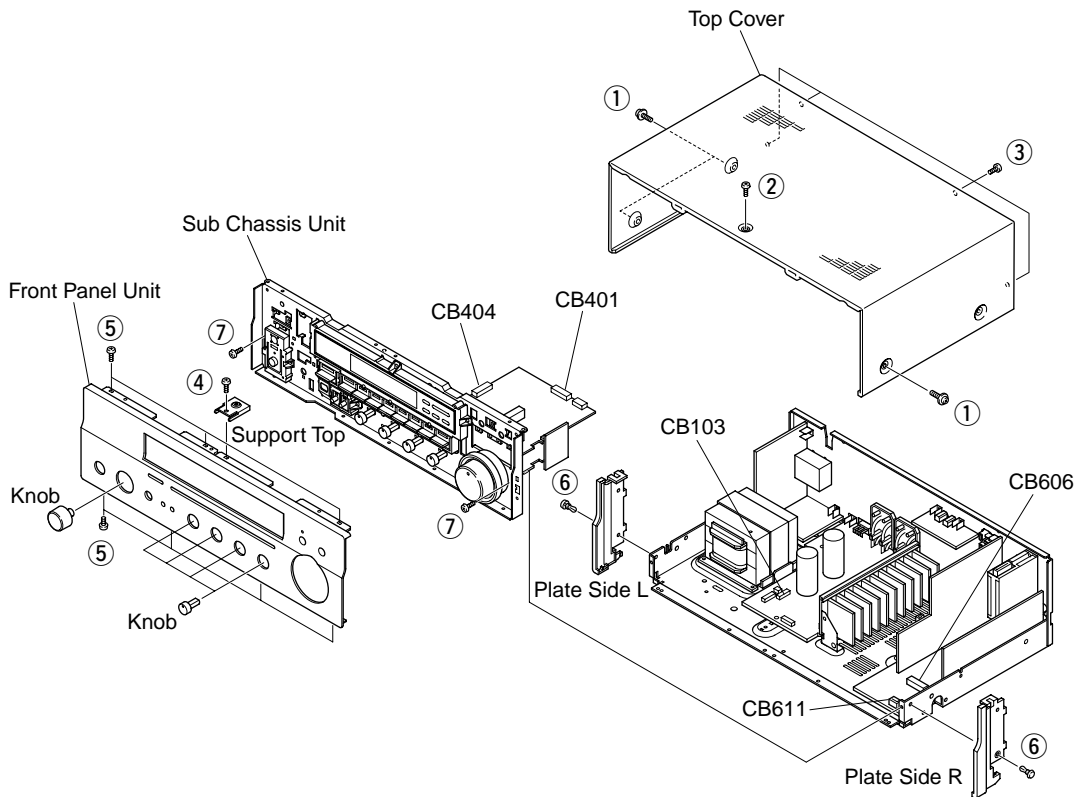

Fig. 1

■ SELF DIAGNOSIS FUNCTION

This product has a built-in self diagnosis function (DIAG) to facilitate inspection, measurement and determination of a faulty item, if any. There are 8 DIAG menu items, each having sub-menu items.

No.	DIAG menu	Sub-menu
1	DISPLAY CHECK	1. VFD CHECK (Initial display)
		2. VFD DISP OFF (All segments OFF)
		3. VFD DISP ALL (All segments ON 100%)
		4. VFD DIMMER (All segments ON 50%)
		5. CHECKED PATTERN (ON in lattice)
2	FACTORY PRESET	1. PRESET INHI (memory initialization inhibited)
		2. PRESET RSRV (memory initialized)
3	AD DATA CHECK	1. DC/PS (protection)
		2. THM L, R
		3. REC-OUT (No applied to this model)
		4. K0 / K1 (panel key)
4	XM STATUS	1. XMS1 (No applied to this model)
		2. XMS2 (No applied to this model)
5	PROTECTION SETTING	1. PS_Lo :
		2. PS_Hi :
		3. DC_Lo :
		4. DC_Hi :
		5. TEMP :
6	PROTECTION HISTORY	1. history 1
		2. history 2
		3. history 3
		4. history 4
7	SOFT SWITCH	1. SW MODE : PCB (/MODEL/FNC)
		2. MODEL SETTING : RX397 (/RX797/RX497)
		3. DESTINATION : UC (/RL/A/BG)
		4. TUNER DESTINATION : (/RL/ABG)
		5. TUNER TYPE : NRM (/RDS/XM)
		6. ZONE2 : EXIST (/NOT) (No applied to this model)
8	MICROPROCESSOR INFORMATION	1. VERSION
		2. CHECK SUM
		3. OPE / XM
		4. PORT
		5. EE SUM

● Starting DIAG

Press the "STANDBY/ON" key of the main unit while simultaneously pressing the "FM/AM" key and the "8" key to activate the DIAG function.

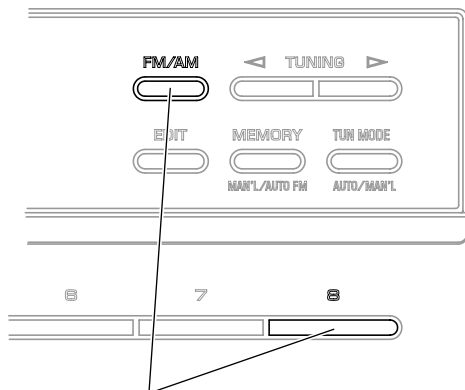

Turn on the power while pressing these keys.

● Starting DIAG in the protection cancel mode

If the protection function works and causing hindrance to trouble diagnosis, cancel the protection function as described below and it will be possible to enter the DIAG mode. (The protection functions other than the excess current detect function will be disabled.)

Press the "STANDBY/ON" key while simultaneously pressing those two keys indicated in the figure above. At this time, keep pressing those two keys for 3 seconds or longer. In this mode, the "SLEEP" segment of the FL display of the main unit flashes to indicate that the mode is DIAG mode with the protection functions disabled.

CAUTION!

Using this product with the protection function disabled may cause damage to itself. Use special care for this point when using this mode.

● Canceling DIAG

- 1 Before canceling DIAG, execute setting for PRESET of DIAG menu No.2 (Memory initialization inhibited or Memory initialized).
 - * **In order to keep the user memory stored, be sure to select PRESET INHIBITED (Memory initialization inhibited). Protection history will remain in memory.**
- 2 Turn off the power by pressing the "STANDBY/ON" key of the main unit.

● Display provided when DIAG started

On the FL display of the main unit, an opening message (including the version and the protection history) appears for a few seconds followed by the diagnostic menu display (1. VFD CHECK).

When there is no history of protection function:

Opening message

When there is no protection history.

```
NO PROTECT Z
```

Version (1 alphabet)



After a few seconds.

DIAG menu display

```
1. VFD CHECK
```

When there is a history of protection function:

The FL display appears as shown below depending on the type of the protection function.

The protection function worked due to excessive current through the amplifier. The protection function activates immediately to turn off the power, with no history display at turn-on, if the amplifier is defective.

```
I PROTECT Z
```

The protection function worked due to a defect or overload in the power supply. The abnormal voltage is displayed in % based on 5V as 100%. If the power is turned on with the abnormality unsolved, the protection function works in about 1 second to turn off the power.

```
PS PRT :000 Z
```

The protection function worked due to a DC voltage appearing at the speaker terminal.

A cause could be a defect in the amplifier. If the power is turned on with the abnormality unsolved, the protection function works in about 3 seconds to turn off the power.



DC PRT :000 Z

The protection function worked due to the temperature limit being exceeded. Causes could be poor ventilation or a defect related to the thermal sensor. The abnormal voltage is displayed in % based on 5V as 500%. If the power is turned on with the abnormality unsolved, the protection function works in about 1 second to turn off the power.



TMR PRT:000 Z

For detection of each protection function (except I-PROTECT) , refer to DIAG MENU No.3 AD DATA CHECK (p.13).

● History of protection function

When the protection function has worked, its history is stored in memory with a backup. Even if no abnormality is noted while servicing the unit, an abnormality which has occurred previously can be defined as long as the backup data has been stored.

The history of the protection function is cleared when DIAG is cancelled by selecting PRESET RESERVED (Memory initialized) of DIAG menu No.2 or when the backup data is erased.

● Display during menu operation

During the DIAG operation, the function at work is indicated on the FL indicator. The contents displayed during the function operation are described later in the “Details of DIAG menu” section.

● Operation procedure of DIAG MENU and SUB-MENU

There are 8 MENU items, each of which has some SUB-MENU items.

DIAG menu selection

Select the menu using PRESET NO keys.

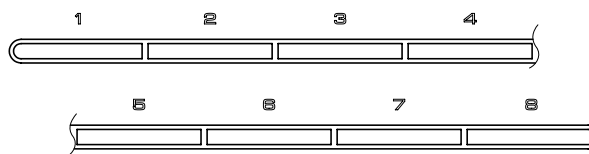

SUB-MENU selection

Select the sub-menu using ▷ (Forward) and ◁ (Reverse) keys of TUNING.

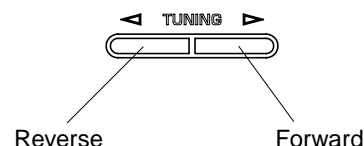

● Functions in DIAG mode

In addition to the DIAG menu items, functions as listed below are available.

- Input selection
- Muting
- Power on/off
- Master volume

* Functions related to the tuner is not available.

● Initial settings used to start DIAG

The following initial settings are used when starting DIAG. When DIAG is canceled, these settings are restored to those before starting DIAG.

- Input: DVD
- Audio mute: OFF
- DIAG menu: DISPLAY CHECK (1. VFD CHECK)

1. DISPLAY CHECK

This program is used to check the FL display section. The display condition varies as shown below according to the sub-menu operation.

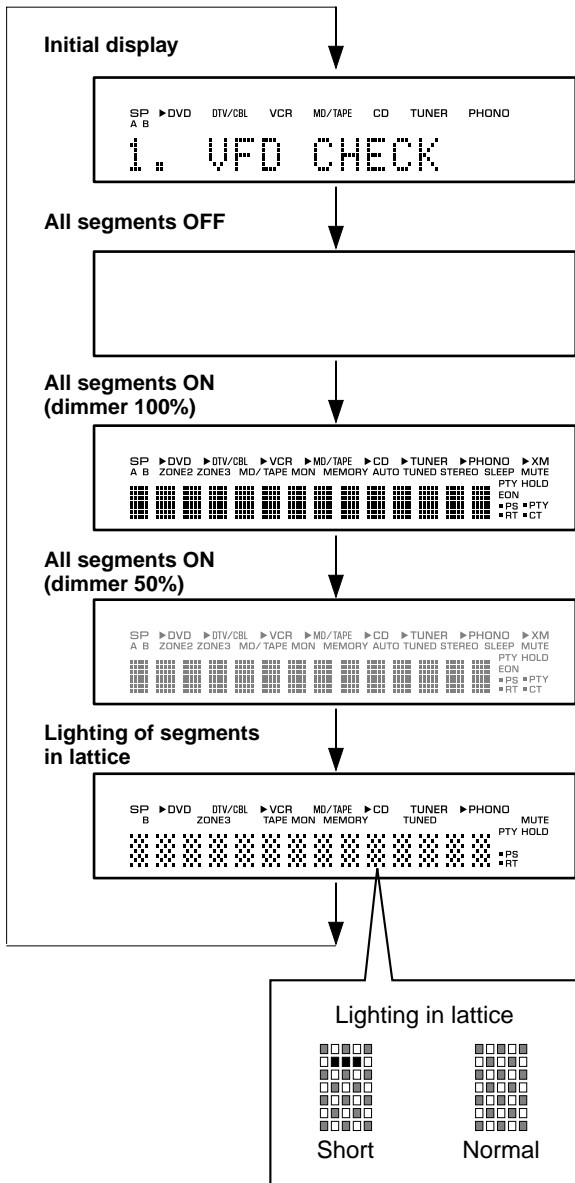

Segment conditions of the FL driver and the FL tube are checked by turning ON and OFF all segments. Next, the operation of the FL driver is checked by using the dimmer control. Then a short between segments next to each other is checked by turning ON and OFF all segments alternately (in lattice). (In the above example, the segments in the second row from the top are shorted.)

2. FACTORY PRESET

This menu is used to reserve/inhibit initialization of the back-up RAM.

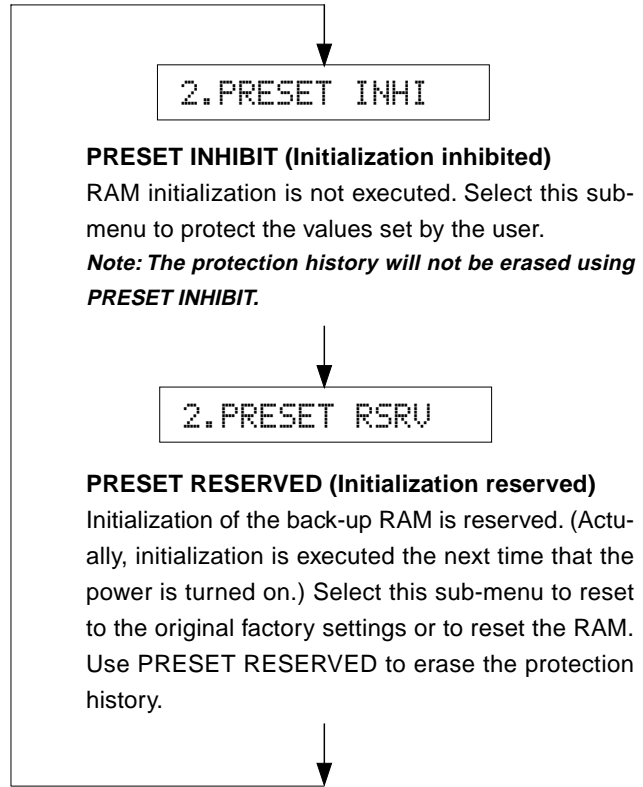

CAUTION: Before setting to the PRESET RESERVED, write down the existing preset memory content of the Tuner in a table as shown below. (This is because setting to the PRESET RESERVED will cause ALL user memory contents to be erased.)

Preset group	P1	P2	P3	P4
A				
B				
C				
D				
E				

Preset group	P5	P6	P7	P8
A				
B				
C				
D				
E				

● PRESET STATIONS

STATION		FM FACTORY PRESET DATA (MHz)	
PAGE	NO.	U, C	R, A, G, E, L
A/C/E	1	87.5	87.50
	2	90.1	90.10
	3	95.1	95.10
	4	98.1	98.10
	5	107.9	108.00
	6	88.1	88.10
	7	106.1	106.10
	8	107.9	108.00

STATION		AM FACTORY PRESET DATA (kHz)	
PAGE	NO.	U, C, R	A, G, E, L
B/D	1	630	630
	2	1080	1080
	3	1440	1440
	4	530	531
	5	1710	1611
	6	900	900
	7	1350	1350
	8	1400	1404

3. AD DATA CHECK

With this sub-menu used, the key scanning, A/D value of the voltage at the abnormality detect (protection) port, etc. are displayed. The A/D conversion value is displayed in %. The state before audio signal processing is kept.

When K0/K1 menu is selected, keys become nonoperable due to detection of the values of all keys.

However, it is possible to advance to the next sub-menu by turning the INPUT of the main unit. When using this function, note that turning the INPUT more than 2 clicks will cause the volume value to change.

** The numeric value in the diagram is for reference.*

DC/PS (protection detection)

DC: DC detect protection value

Normal value: 19 to 51 (Reference: 5V = 100%)

PS: Power supply voltage protection value

Normal value: 28 to 62 (Reference: 5V = 100%)

When the value is outside of the normal range, the protection function works to turn off the power.

DC:035 PS:035

THM (temperature detection)

When the value is outside of the normal range, the protection function works to turn off the power.

500% display of the voltage based on the temperature detected value. Reference voltage: 5V

** For RX-397, only R ch is effective.*

THM:L000 R098

REC-OUT

Not applied to this model.

REC-OUT:225

K0/K1

This is the A/D value of the panel key input ports KEY0 and KEY1 (microprocessor). The table below shows the A/D value obtained when each key is pressed. When the value is not within the standard value range, no correct operation is provided. Referring to the table below, check the value of each voltage dividing resistor of each key, solder condition, etc.

K0:100 K1:099

	%	Key0	Key1
1	0 – 4	FM/AM	P8
2	4 – 12	TUNING DOWN	P7
3	12 – 21	TUNING UP	P6
4	21 – 30	TUNING MODE	P5
5	31 – 41	MEMORY	P4
6	42 – 52	EDIT	P3
7	52 – 61		P2
8	61 – 68	SPEAKER B	P1
9	68 – 74	SPEAKER A	A/B/C/D/E
10	75 – 81		
11	81 – 89		

4. XM STATUS

Not applied to this model.

4. XM51xxxxxxxx



4. XM52xxxxxxxx

5. PROTECTION SETTING

This menu is used to change the protection setting value. The change is effective in this menu only. A set value can be specified between 0 – 255 (0V – 5V).

Operation:

Change the digit with the “EDIT” key.

UP / DOWN with the TUNING MODE / MEMORY key.

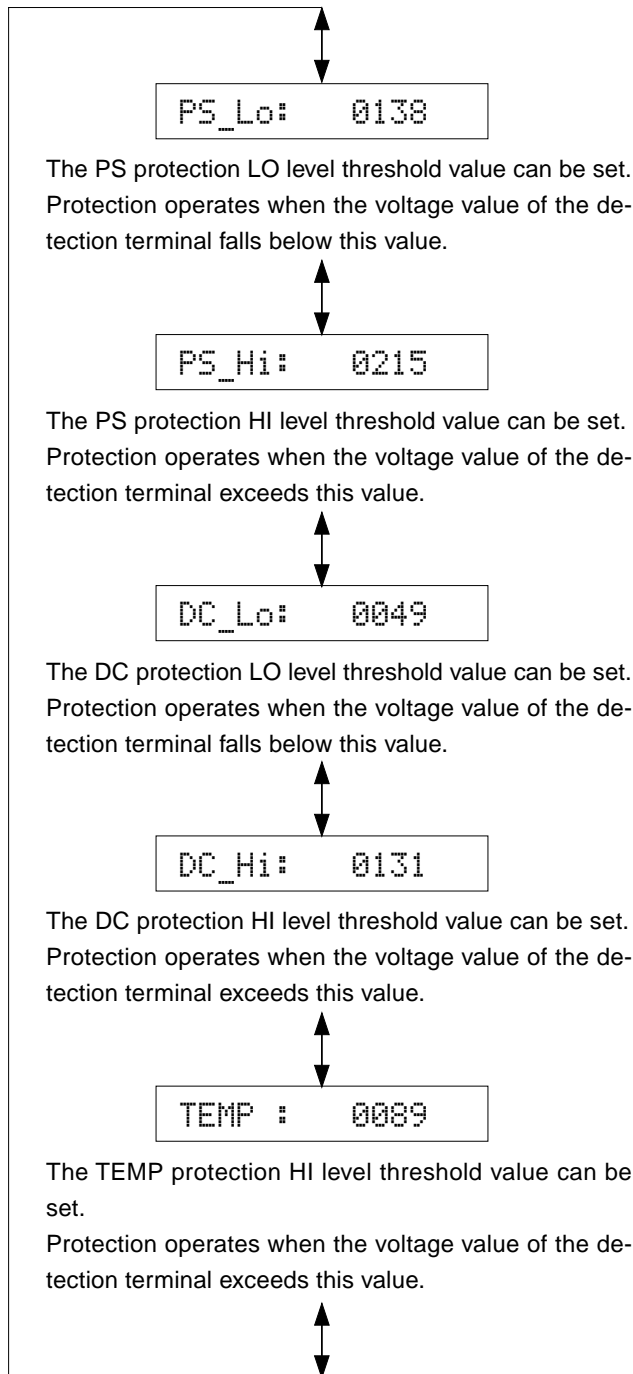

6. PROTECTION HISTORY

Four protection histories are display.

The history is cleared by the initialization reservation of DIAG menu No. 2.

When there is no history of protection function:

There is no history of protection function.

```
6-1 NoPRT
```

When there is a history of protection function:

There is a history of protection function due to excess current.

```
6-1 I PRT
```

There is a history of protection function due to abnormal voltage in the power supply section.

The abnormal voltage is displayed in % based on 5V as 100%.

```
6-2 PsPRT 069
```

There is a history of protection function due to abnormal DC output.

The abnormal voltage is displayed in % based on 5V as 100%.

```
6-3 DcPRT 059
```

There is a history of protection function excessive heatsink temperature. (R ch)

The abnormal voltage is displayed in % based on 5V as 500%.

```
6-4 TmRPRT 245
```

There is a history of protection function excessive heatsink temperature. (L ch)

Not applied to this model.

```
6-4 TmLPRT 245
```

**The numeric value in the diagram is for reference.*

7. SOFT SWITCH

Note) Changing the function setting may hinder the proper operation.

This menu is used to switch the function settings on P.C.B. through the software so as to activate the product.

The operation mode can be changed by selecting the sub-menu and then using the EDIT key.

The protection function follows the P.C.B. settings.

When connected to AC, the unit is initialized to the P.C.B. setting. Display of each function after initialization varies depending on settings on P.C.B.

SW MODE: PCB, MODEL or FNC can be selected.

7.SW :PCB

MODEL SETTING: RX797, RX497 or RX397 can be selected. (SW MODE: Selectable when MODEL has been selected.)

7.MODEL :RX397

DESTINATION: UC / RL / A or BGE can be selected. (SW MODE: Selectable when MODEL has been selected.)

7.DEST :UC

TUNER DEST INATION: UC, RL or ABGE can be selected. (SW MODE: Selectable when FNC has been selected.)

7.TuDest :UC

TUNER TYPE: NRM, RDS or XM can be selected. (SW MODE: Selectable when FNC has been selected.)

7.TuTyP :NRM

ZONE2: NOT or EXIST can be selected. (SW MODE: Selectable when FNC has been selected.)

7.ZONE2 :NOT

8. MICROPROCESSOR INFORMATION

The version, checksum and the port specified by the microprocessor are displayed. The checksum is obtained by adding the data at every 16 bits for each program area and expressing the result as a 4-figure hexadecimal data.

**The numeric value in the diagram is for reference.*

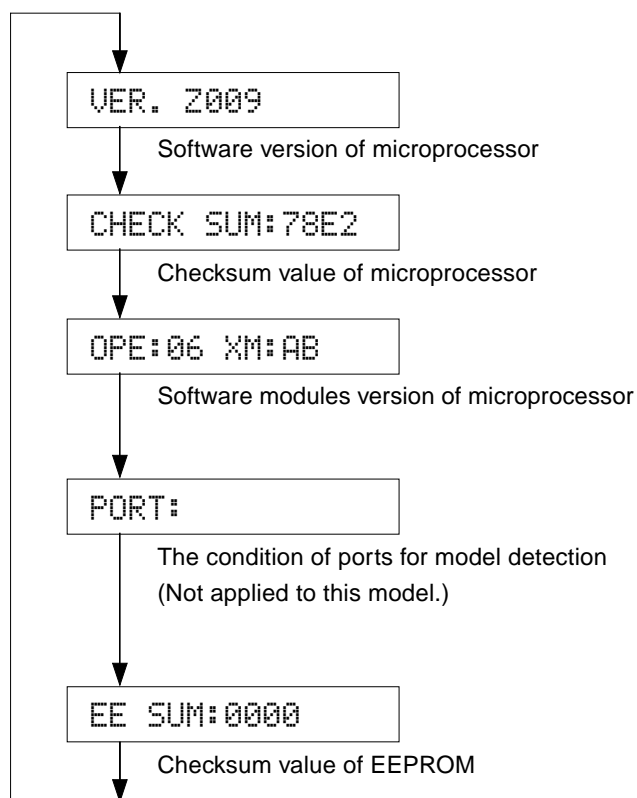

Tuner Dest	Frequency Range		Comment
	FM	AM	
UC	87.5-107.9MHz/200kHz	530-1710kHz/10kHz	
RL	87.5-108.0MHz/50kHz	531-1611kHz/9kHz	The frequency range is selected with Advanced Set Up
	87.5-108.0MHz/100kHz	530-1710kHz/10kHz	
ABG	87.5-108.0MHz/50kHz	531-1611kHz/9kHz	

■ AMP ADJUSTMENT

● CONFIRMATION OF IDLING CURRENT

1. Right after the power is turned on, confirm that the voltage across the terminals of R137 (L ch) and R138 (R ch) are between 0.1mV to 10.0mV.
2. If the measured voltage exceeds 10.0mV, open (cut off) R131 (L ch), R132 (R ch) and reconfirm the voltage.
3. Confirm that the voltage is between 0.20mV and 15.0mV after 60 minutes.

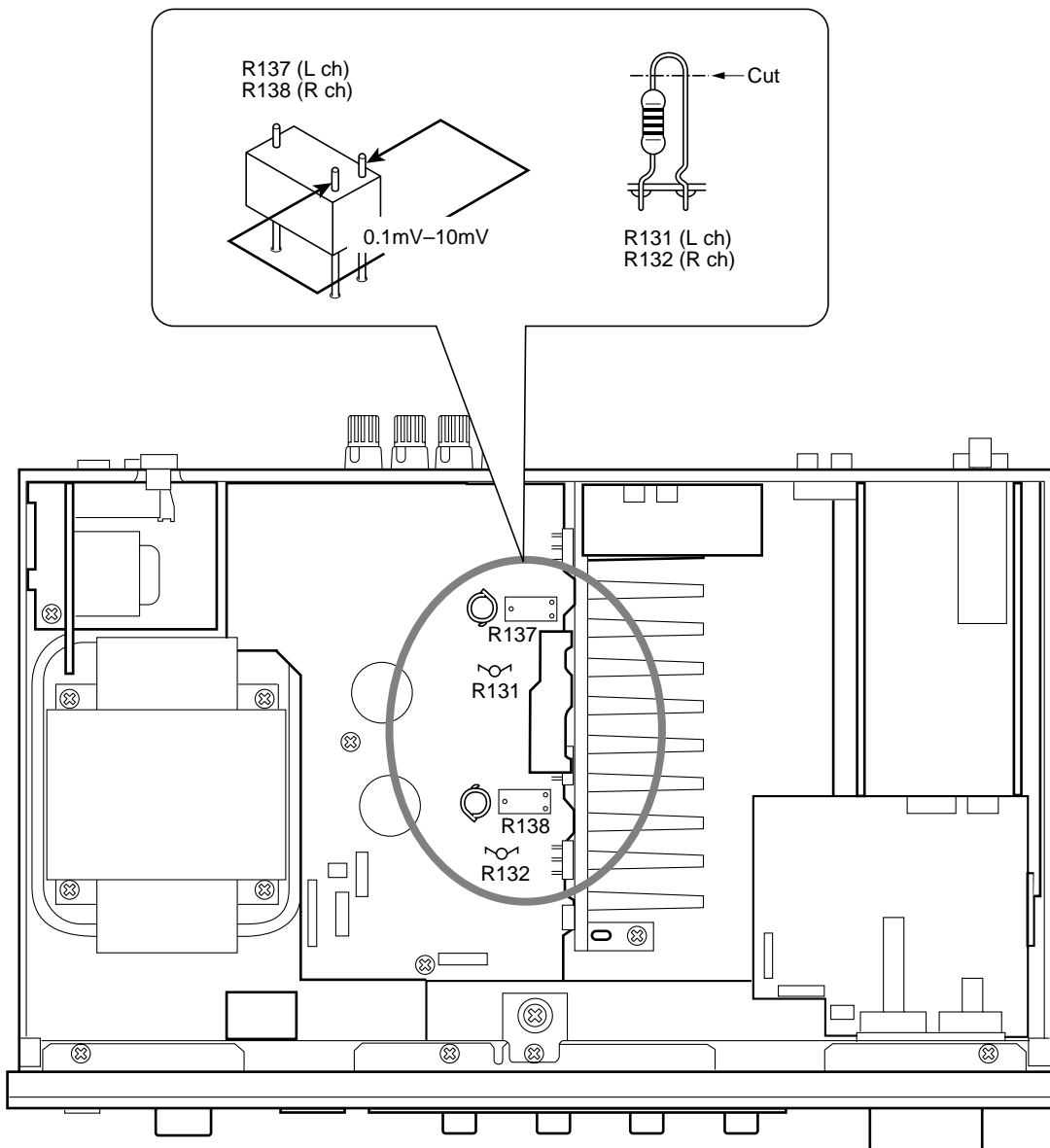

■ IC DATA

IC602 : M30626FHPFP (FUNCTION (2) P.C.B.)
16-bit Microprocessor

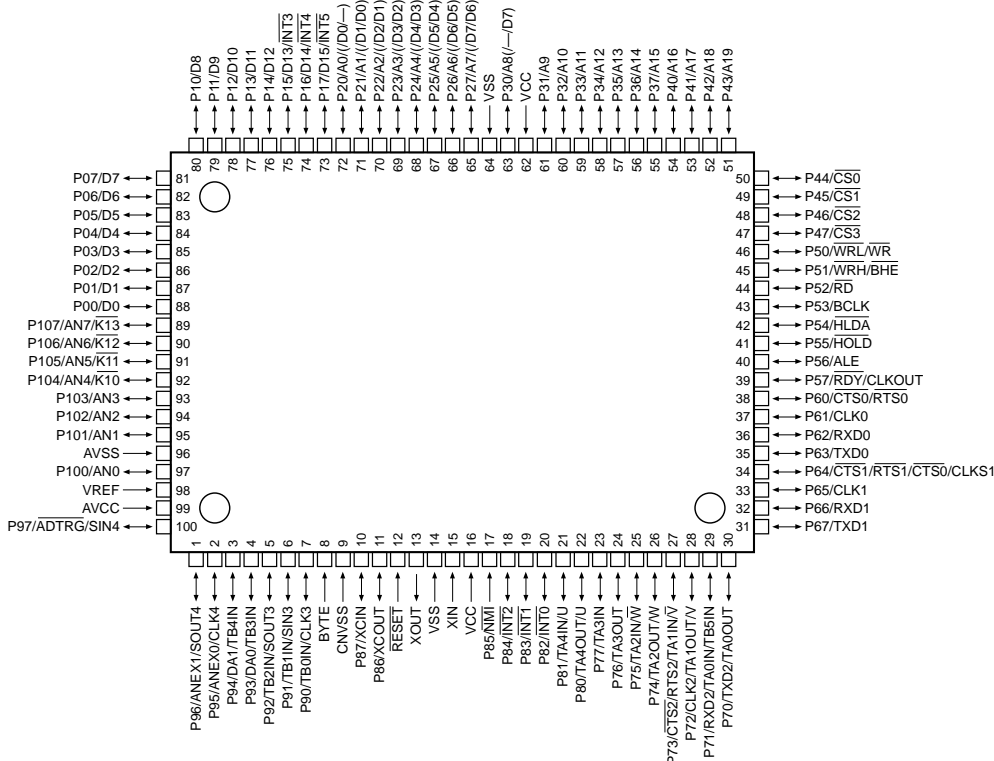

No.	Port	Name	I/O	Function
1	P96/ANEX1	DTFD	O	FL Driver Tx DATA
2	P95/ANEX0	CKFD	O	FL Driver CLOCK
3	P94		O	
4	P93	DEST1	I	Model Distinction 1
5	P92/TB2in	DEST0	I	Model Distinction 0
6	P91/TB1in	MOD1	I	Destination Distinction 1 (Reserve)
7	P90/TB0in	MOD0	I	Destination Distinction 0 (Reserve)
8	BYTE	BYTE	MCU	Vss: when single chip mode is used (Gnd)
9	CNVss	CNVss	MCU	Vss: when single chip mode is used, Vcc: when flash writing is used (PullDown)
10	P87/Xcin	/CEEEP	O	EEPROM CE
11	P86/Xcout	N.C.	O	
12	/RESET	/RESET	MCU	Reset
13	Xout	Xout	MCU	Oscillator Out
14	Vss	Vss	MCU	Ground (Gnd)
15	Xin	Xin	MCU	Oscillator In
16	Vcc1	Vcc	MCU	Power Supply, +5V (Vcc)
17	P85/NMI	NMI	I	Connect to Vcc because it is unused (PullUp)
18	P84/INT2	MPSW	IRQ	MAIN Power SW INT
19	P83/INT1	ZPSW	IRQ	Zone2 Power SW INT
20	P82/INT0	PDET	IRQ	Power Down Detect INT
21	P81	N.C.	O	(LevelConv)
22	P80	N.C.	O	(LevelConv)
23	P77	TRIG	O	Triger OUT (Unconnected)
24	P76	/POMT	O	Pre Out Mute (Unconnected)
25	P75/TA2in	/Z2MT	O	Zone2 Mute (Unconnected)
26	P74/TA2out	N.C.	O	
27	P73/CTS2/RTS2/TA1in	XMPWR	O	XM/DT BUS POWER CONTROL (Unconnected)
28	P72/CLK2/TA1out	/ICXM	O	DABIC IC Reset (Unconnected)
29	P71/RXD2/SCL2/TA0in	DRXM	SI	DABIC IC RxD (Unconnected)
30	P70/TXD2/SDA2/TA0out	DTXM	SO	DABIC IC TxD (Unconnected)
31	P67/TXD1/SDA1	DTEV	SO	Zone2Volume Tx DATA(YAC526) (Unconnected)
		TXDF	SO	Data Transmit Terminal for AF220
32	P66/RXD1/SCL1	CEEV	O	Zone2Volume CE(YAC526) (Unconnected)
		RXDF	SO	Flash ROM RxD
33	P65/CLK1	CKEV	SO	Zone2Volume CLOCK(YAC526) (Unconnected)
		CLKF	SO	Clock Transmit Terminal for AF220

**IC602 : M30626FHPFP (FUNCTION (2) P.C.B.)
16-bit Microprocessor**

No.	Port	Name	I/O	Function
34	P64/CTS1/RTS1/CTS0/CLKS1	BSY	O	AF220 BUSY Signal Output
35	P63/TXD0/SDA0	DTIS	SO	Input Selector Tx DATA
36	P62/RXD0/SCL0	CEIS	O	Input Selector CE
37	P61/CLK0	CKIS	SO	Input Selector CLOCK
38	P60/CTS0/RTS0	DTRZ	O	Rec/Zone2 selector DATA (Unconnected)
39	P57/RDY/CLKout	CKRZ	O	Rec/Zone2 selector CLOCK (Unconnected)
40	P56	N.C.	O	
41	P55	/EMP	I	For Flash Writing (LO) (PullDown)
42	P54	CER	O	RDS CE
43	P53	SCKR	O	RDS CLOCK
44	P52	SDRR	I	RDS Rx DATA
45	P51	SDTR	O	RDS Tx DATA
46	P50	/CE	I	For Flash Writing (HI) (PullUp)
47	P47	CEP	O	TUNER CE
48	P46	SCKP	O	TUNER CLOCK
49	P45	SDTP	O	TUNER Tx DATA
50	P44	/TMU	O	TUNER MUTE
51	P43	SDRP	I+	TUNER Rx DATA
52	P42	TUNED	I+	TUNER TUNED
53	P41	/ST	I+	TUNER /ST
54	P40	N.C.	O	
55	P37	VIA	O	Video Input SelectorA (Unconnected)
56	P36	VIB	O	Video Input SelectorB (Unconnected)
57	P35	/VR	O	Video Rec Mute (Unconnected)
58	P34	VRB	O	Video Rec SelectorB (Unconnected)
59	P33	VZA	O	VIDEO Zone2 SelectorA (Unconnected)
60	P32	VZB	O	VIDEO Zone2 SelectorB (Unconnected)
61	P31	/SWMT	O	Sub Woofer Mute (Unconnected)
62	Vcc2	Vcc	MCU	Power Supply, +5V (Vcc)
63	P30	/CDMT	O	CD Direct Mute (Unconnected)
64	Vss	Vss	MCU	Ground (Gnd)
65	P27	/MIMT	O	Main IN Mute
66	P26	PDon	I+	Pure Direct ON Detect
67	P25	CDon	I+	Tape Monitor Key
68	P24	PLED	O	Pure Direct LED
69	P23	CLED	O	CD Direct/TapeMonitor LED
70	P22	PRY	O	Power Relay
71	P21	N.C.	O	
72	P20	HPRY	O	Head Phone Relay
73	P17	PDET	IRQ	Power Down Detect INT (Unconnected)
74	P16	SPSW	IRQ	SYSTEM Power SW INT(MasterPower)
75	P15	REM	IRQ	Remote Controler INT
76	P14	FBRY	O	Front B Speaker Relay
77	P13	FARY	O	Front A Speaker Relay
78	P12	VRup	O	Volume Up
79	P11	VRdn	O	Volume Down
80	P10	PRI	I	I Protection
81	P07	/PSV	O	Power save mode
82	P06	N.C.	O	
83	P05	/BLK	O	FL Driver /BLK
84	P04	ISA	I	Input Selector A (PullUp)
85	P03	ISB	I	Input Selector B (PullUp)
86	P02	LSBY	O	StandBy LED (Unconnected)
87	P01	N.C.	O	
88	P00	N.C.	O	
89	P107/AN7/K13	REC	AD	Rec/Zone2 selector (Unconnected)
90	P106/AN6/K12	PRV	AD	PS Protection (PullUp)
91	P105/AN5/K11	PRD	AD	DC Protection (PullUp)
92	P104/AN4/K10	THML	AD	THM L Protection (Unconnected)
93	P103/AN3	THMR	AD	THM R Protection (PullUp)
94	P102/AN2	KEY0	AD	AD Key 0
95	P101/AN1	KEY1	AD	AD Key 1
96	Avss	Avss	MCU	AD Ground (Gnd)
97	P100/AN0	DEST	AD	Destination Detect
98	Vref	Vref	MCU	AD Reference (Vcc)
99	Avcc	Avcc	MCU	AD Power Supply (Vcc)
100	P97/Adtrg	CEFD	O	FL Driver CE

■ DISPLAY DATA

V801 : 15-BT-105GNK (WF519900)

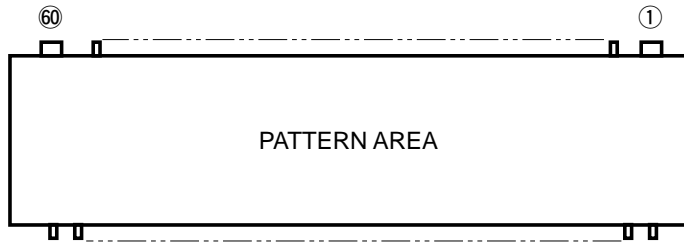

● PIN CONNECTION

PIN NO.	544444444433333333332222222222111111111111111111
CONNECTION	P N N 5 4 3 2 1 0 9 8 7 6 5 4 3 2 1 0 9 8 7 6 5 4 3 2 1 N N N F

PIN NO.	65555555
CONNECTION	F N N N N P P P P P P 2 X P P 1 2 3 4 5 6

- Note 1) F1, F2 Filament
- 2) NP No Pin
- 3) NX No Extend Pin
- 4) P1~P35 Datum Line
- 5) 1G~15G Grid

● GRID ASSIGNMENT

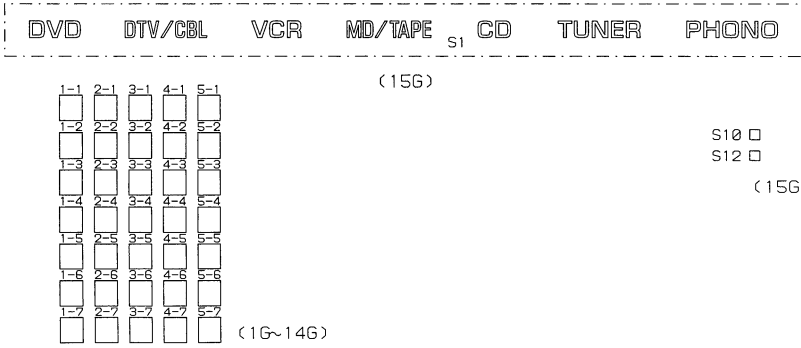
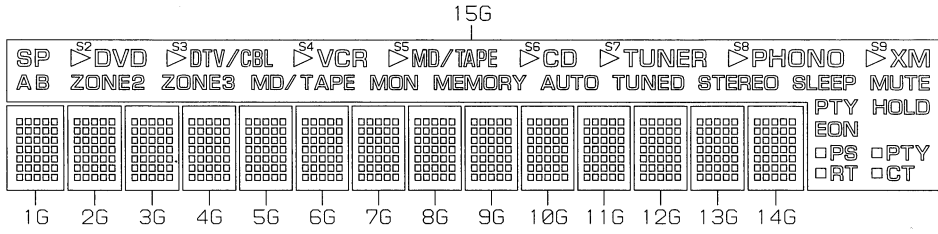

● ANODE CONNECTION

	1G~14G	15G
P1	1-1	SP
P2	2-1	A
P3	3-1	B
P4	4-1	ZONE2
P5	5-1	ZONE3
P6	1-2	MD/
P7	2-2	TAPE MON
P8	3-2	AUTO
P9	4-2	TUNED
P10	5-2	STEREO
P11	1-3	MEMORY
P12	2-3	SLEEP
P13	3-3	PTY HOLD
P14	4-3	EON
P15	5-3	S10
P16	1-4	S11
P17	2-4	S12
P18	3-4	S13
P19	4-4	PS
P20	5-4	PTY
P21	1-5	RT
P22	2-5	CT
P23	3-5	S2
P24	4-5	S3
P25	5-5	S4
P26	1-6	S5
P27	2-6	S6
P28	3-6	S7
P29	4-6	S8
P30	5-6	S9
P31	1-7	S1
P32	2-7	XM
P33	3-7	MUTE
P34	4-7	-
P35	5-7	-

PIN CONNECTION DIAGRAM

ICs

LM61CIZ

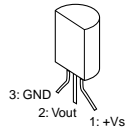

NJU7201L55

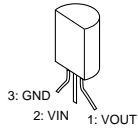

TLP421

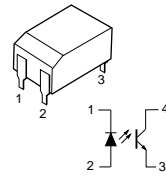

TC4013BP

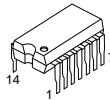

NJM2068MD

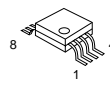

LC72722PM

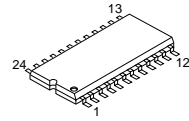

NJU7313AM

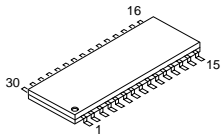

LB1641

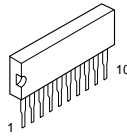

M66003-0131FP

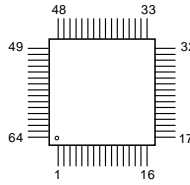

M30626FHPPF

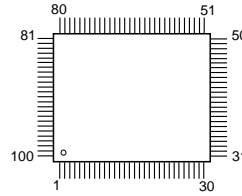

Diodes

- 1SS355
- 1SS380
- MA8056-M
- MA8051-M
- MA8120-H
- UDZS5.1BTE-17
- UDZS3.0BTE-17
- UDZS22BTE-17

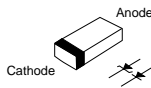

- 1SS133
- 1SS270A
- 1SR139
- 1T2
- MTZJ16A
- MTZJ6.8B
- MTZJ10B
- MTZJ9.1B
- MTZJ6.2B
- MTZJ3.0A
- MTZJ27B

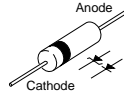

- S1NB20
- S1NB60

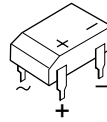

- S4VB20

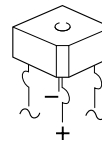

Transistors

- 2SC2412K (Q, R, S)
- DTC144EKA
- 2SA1037K (Q, R, S)
- 2SD1938F (S, T)



- 2SA1708 (S, T)
- 2SC4488 (S, T)

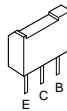

- 2SC1740S (Q, R, S)
- DTC144ESA-TP

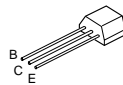

- 2SA1015 (Y)
- 2SC1815 (Y)
- 2N5401C-AT
- 2N5551C-AT
- 2SC2229 (O, Y)
- 2SA970 (GR, BL)
- 2SB647 (C, D)

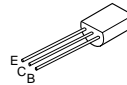

- 2SD2375 (Q, P)



- 2SC4495

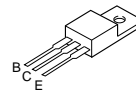

Transistors

- 2SA1695 (O, P, Y)
- 2SC4468 (O, P, Y)

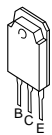

FETs

- 2SK30ATM
- 2SK3850



RX-397

■ PRINTED CIRCUIT BOARD

1

FUNCTION (1) P.C.B. (Side A)

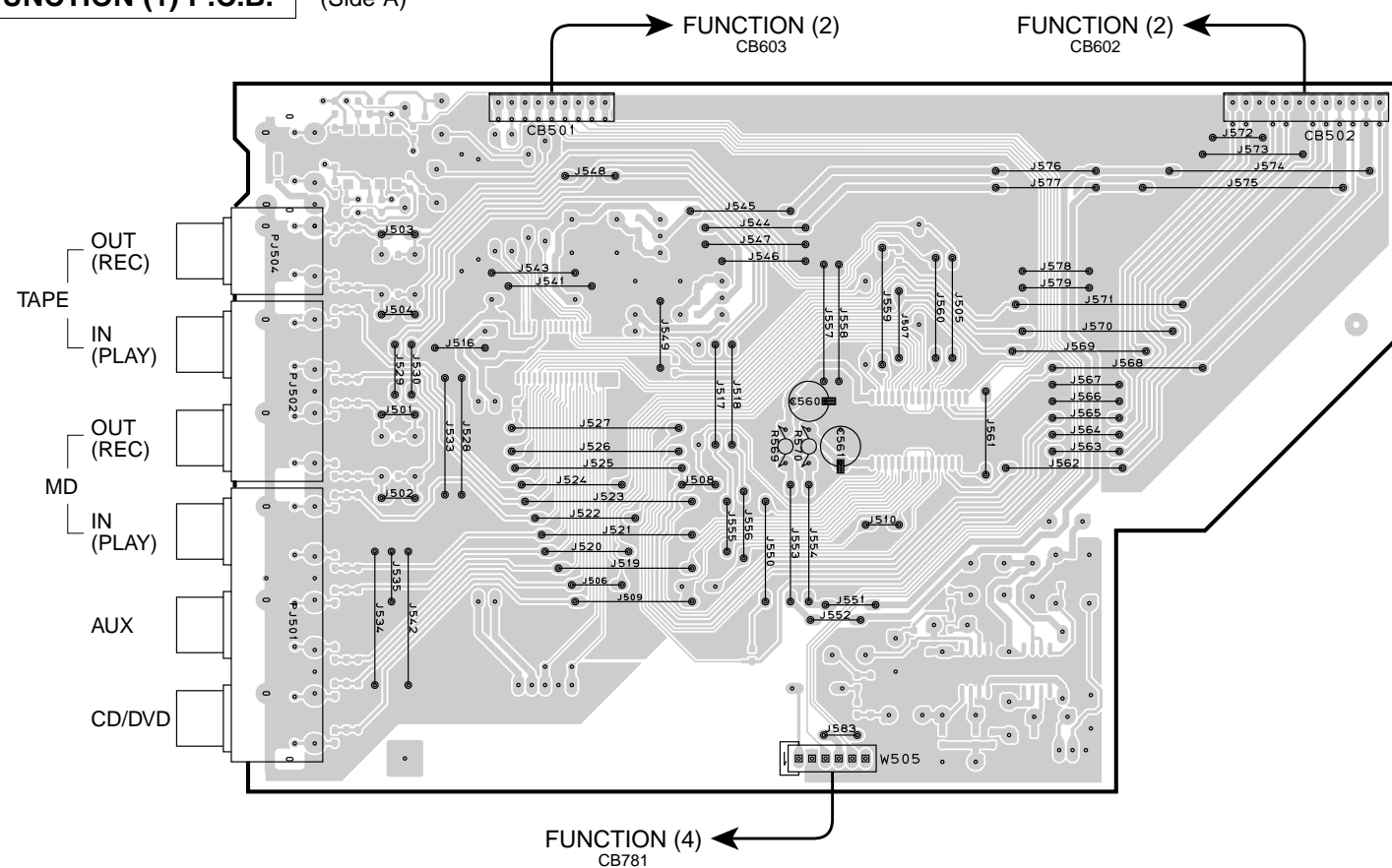

2

3

FUNCTION (1) P.C.B. (Side B) Lead Free Solder Used

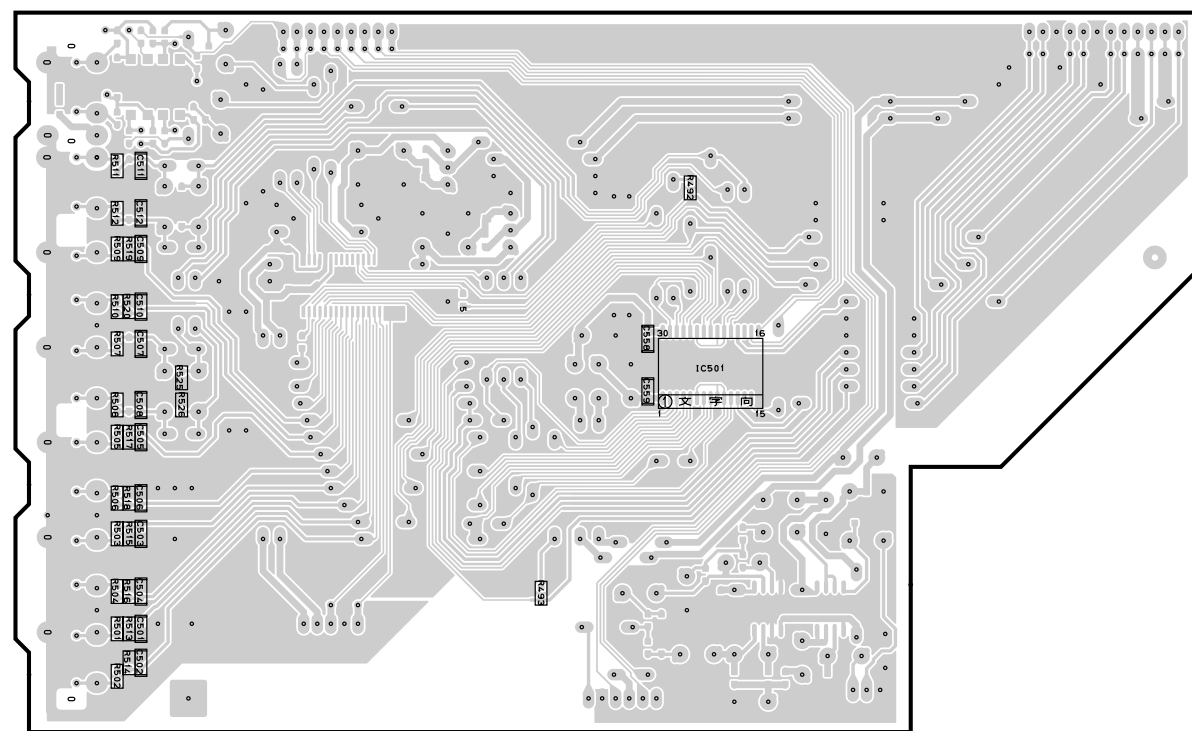

4

5

6

FUNCTION (4) P.C.B. (Side A)

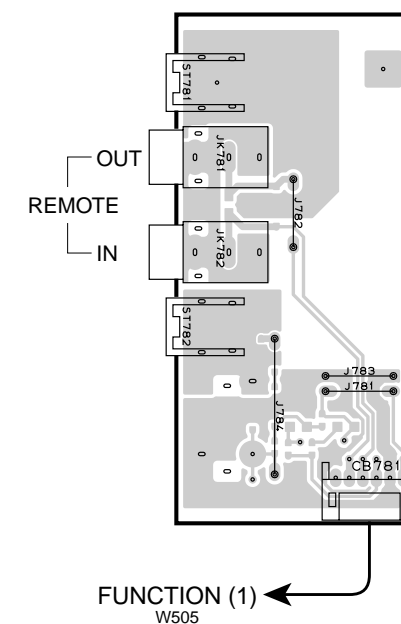

FUNCTION (1) W505

FUNCTION (4) P.C.B. (Side B) Lead Free Solder Used

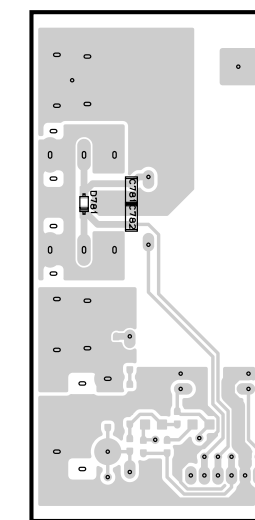

PRINTED CIRCUIT BOARD

FUNCTION (2) P.C.B. (Side A)

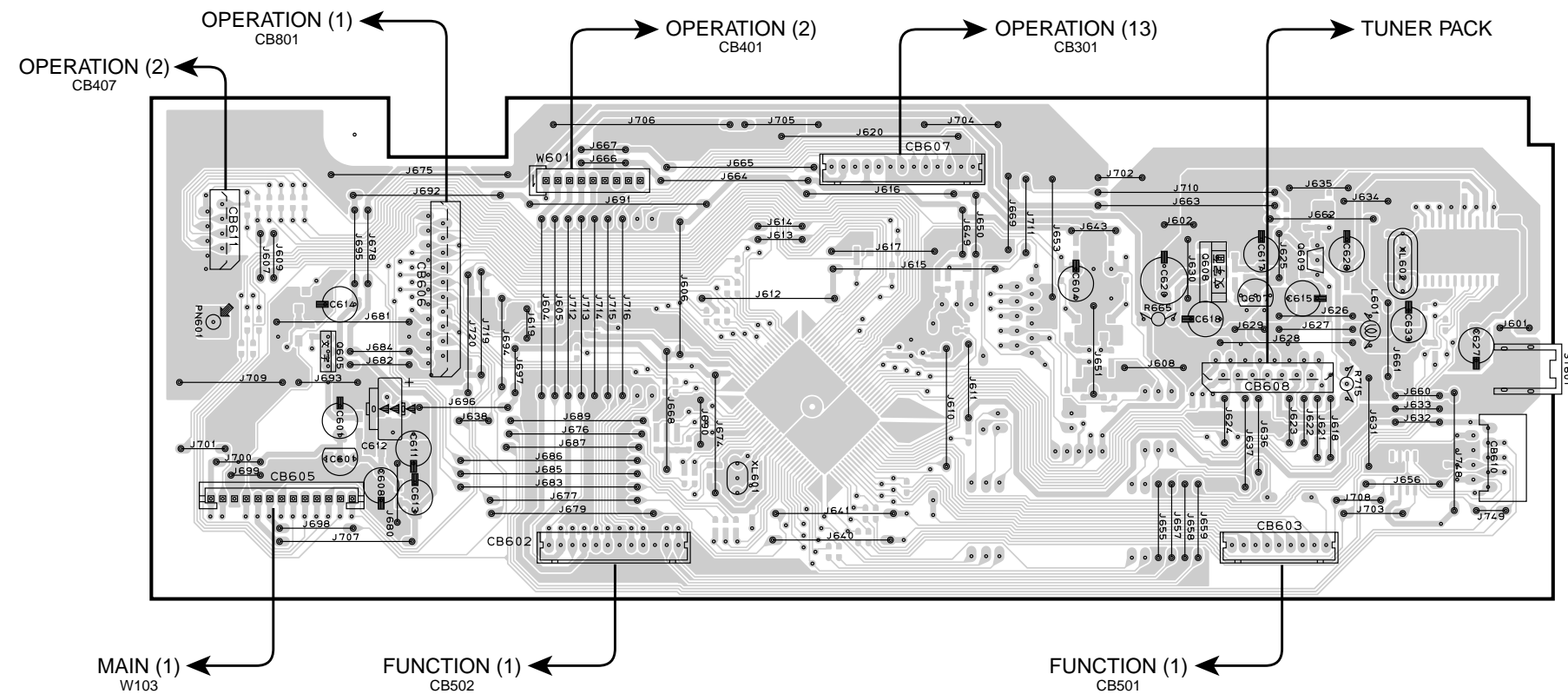

FUNCTION (2)

Circuit No.	U, C	R, L	A	G, E
R613	O	O	O	X
IC603	X	X	X	O
XL602	X	X	X	O
C630, 632	X	X	X	O
C622, 623	X	X	X	O
C629	X	X	X	O
C621, 631	X	X	X	O
C627, 628, 633	X	X	X	O
R698	X	X	X	O
R710, 711	X	X	X	O
R684	X	X	X	O
R714, 717	X	X	X	O
R688	X	X	X	O
R678	X	X	X	O
R677	X	X	X	O
L601	X	X	X	O
Q609	X	X	X	O

X: NOT USED
O: USED/APPLICABLE

FUNCTION (2) P.C.B. (Side B) Lead Free Solder Used

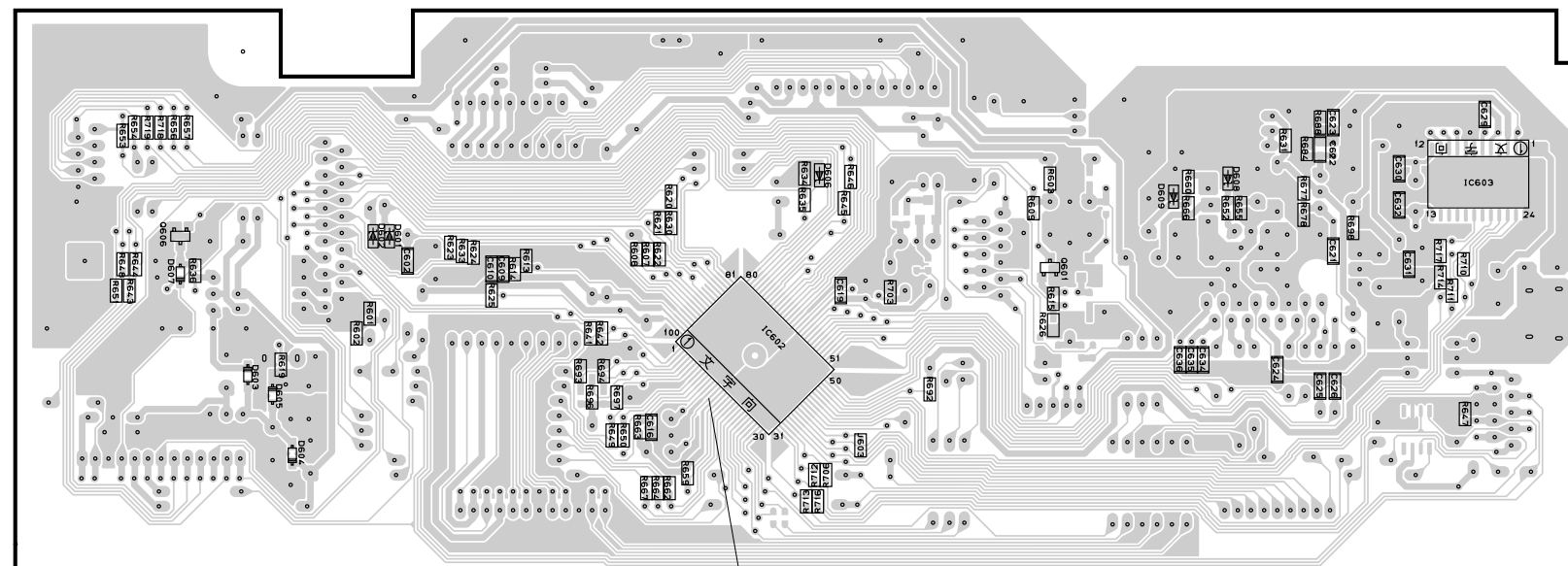

Point ① (Pin 13 of IC602)

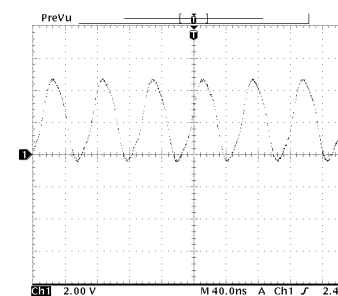

■ PRINTED CIRCUIT BOARD

1

OPERATION (1) P.C.B. (Side A)

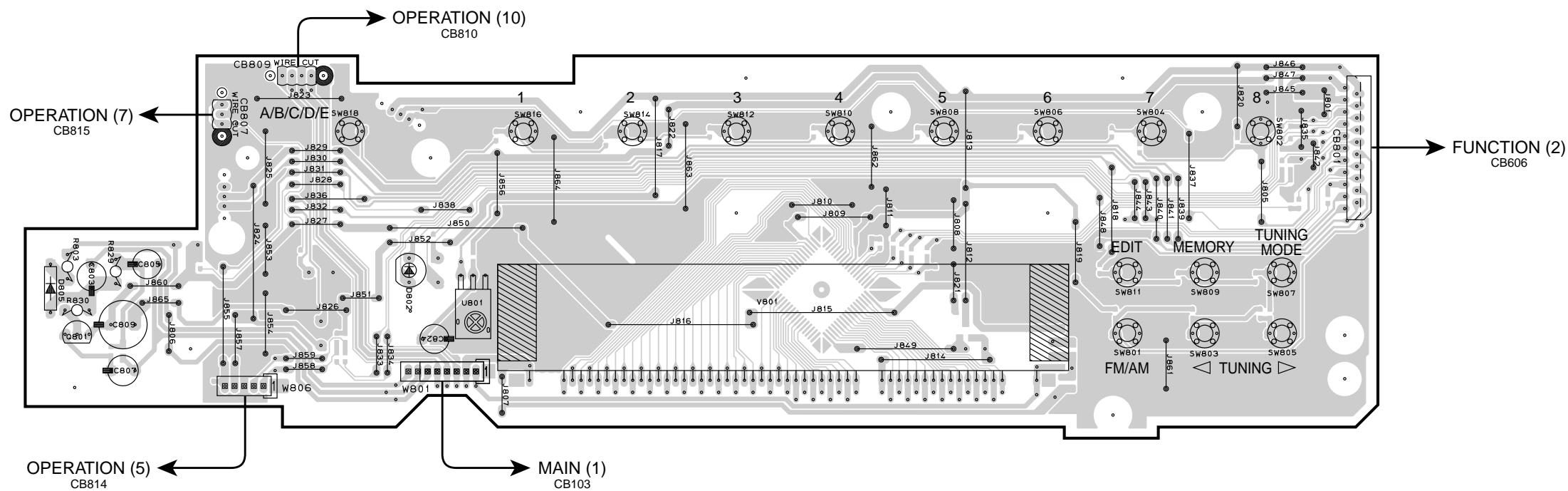

2

3

OPERATION (1) P.C.B. (Side B) Lead Free Solder Used

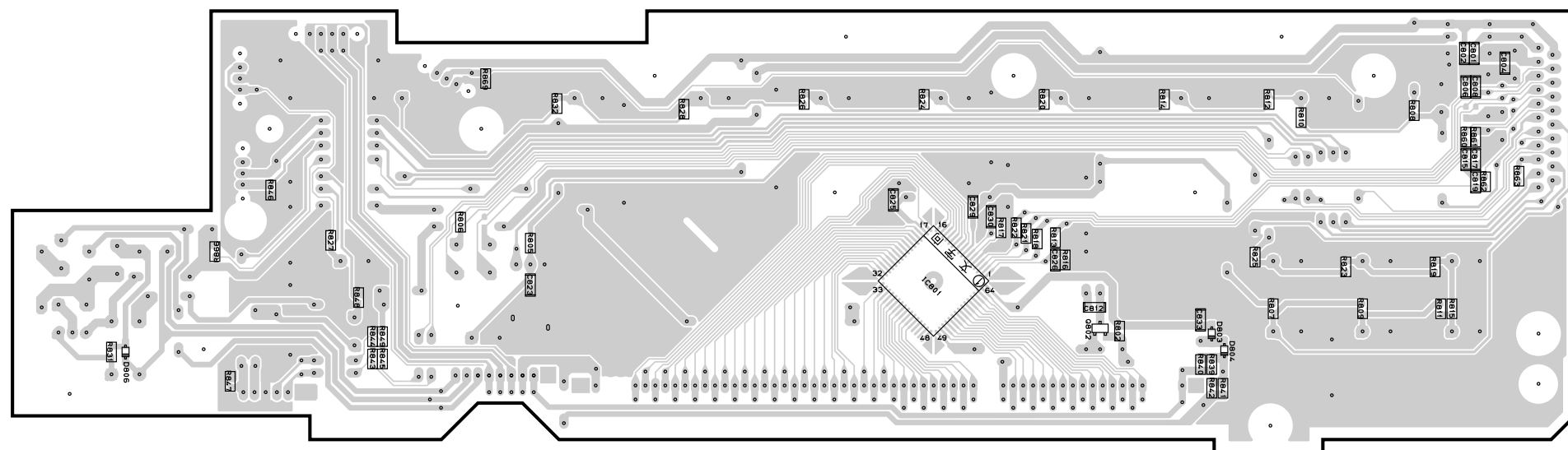

4

5

6

PRINTED CIRCUIT BOARD

OPERATION (2) P.C.B. (Side A)

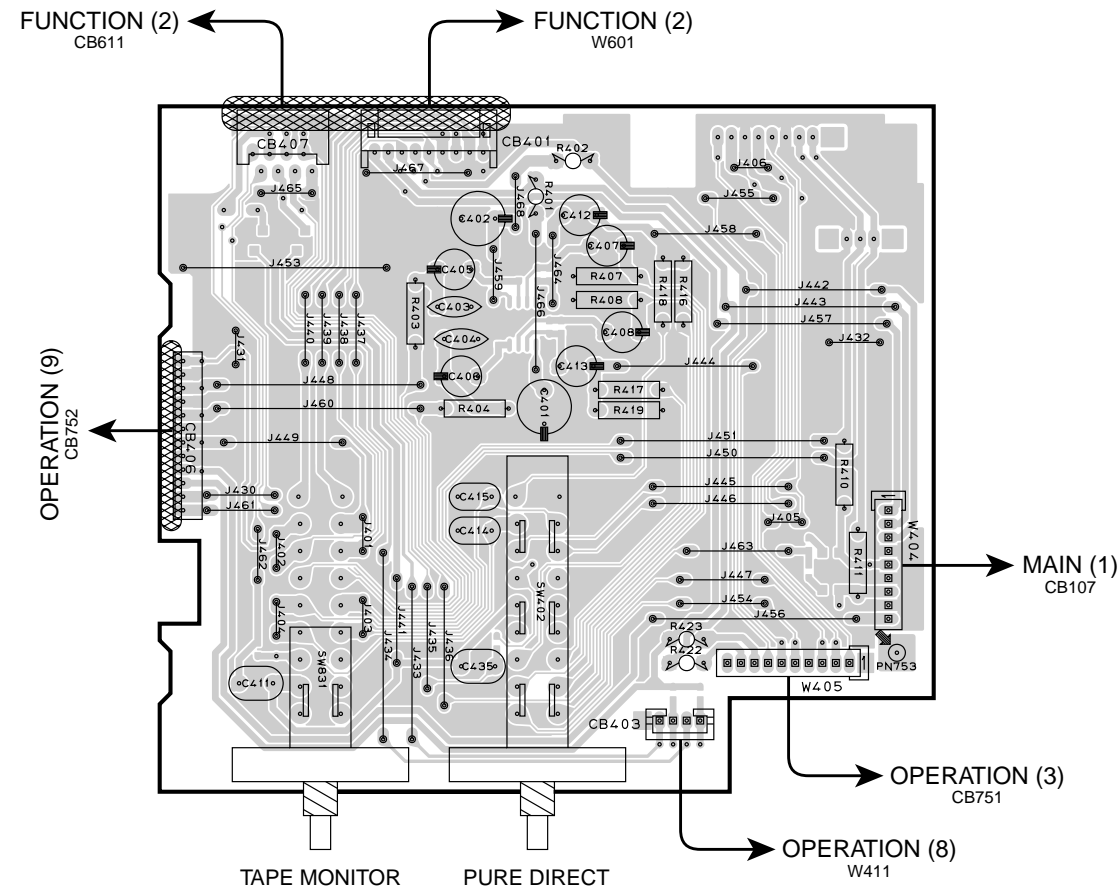

OPERATION (3) P.C.B. (Side A)

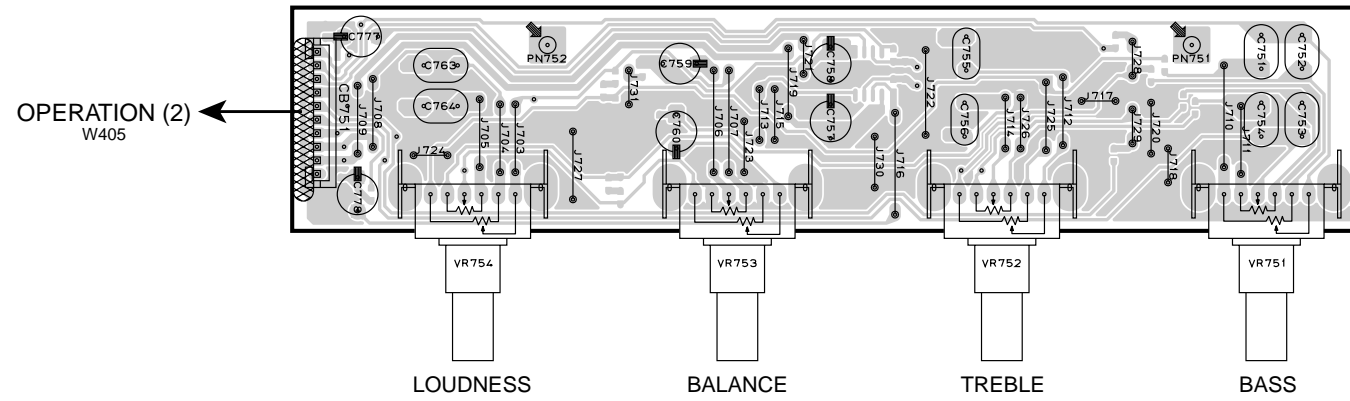

OPERATION (3) P.C.B. (Side B) Lead Free Solder Used

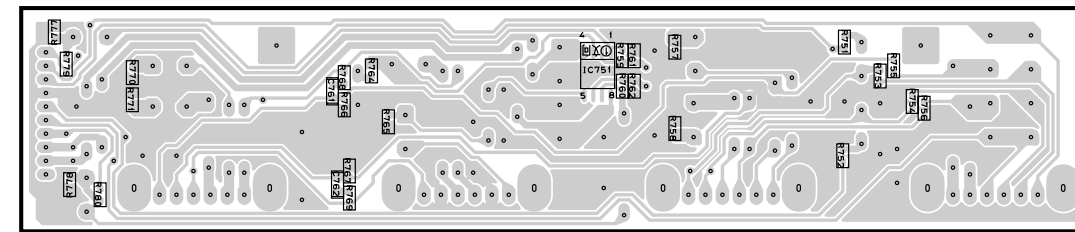

OPERATION (2) P.C.B. (Side B) Lead Free Solder Used

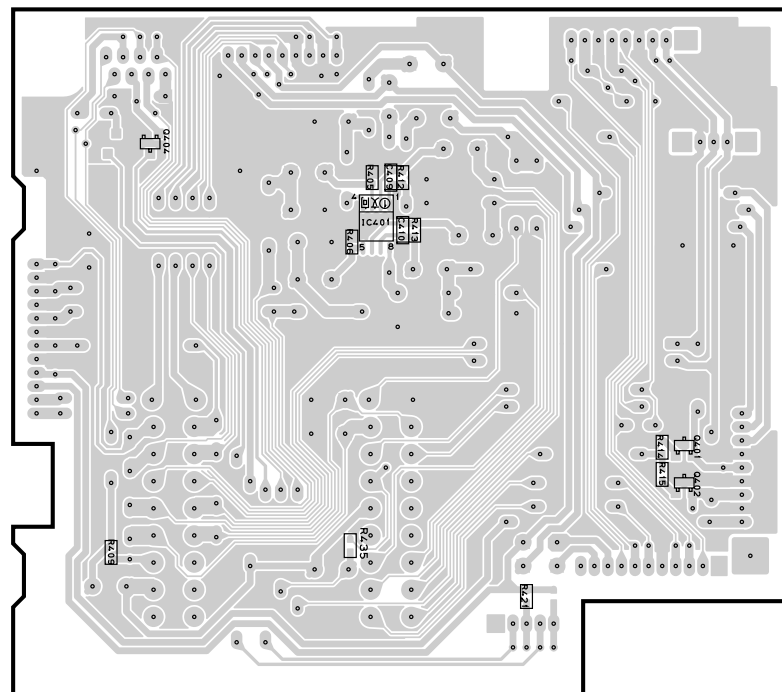

OPERATION (4) P.C.B. (Side A)

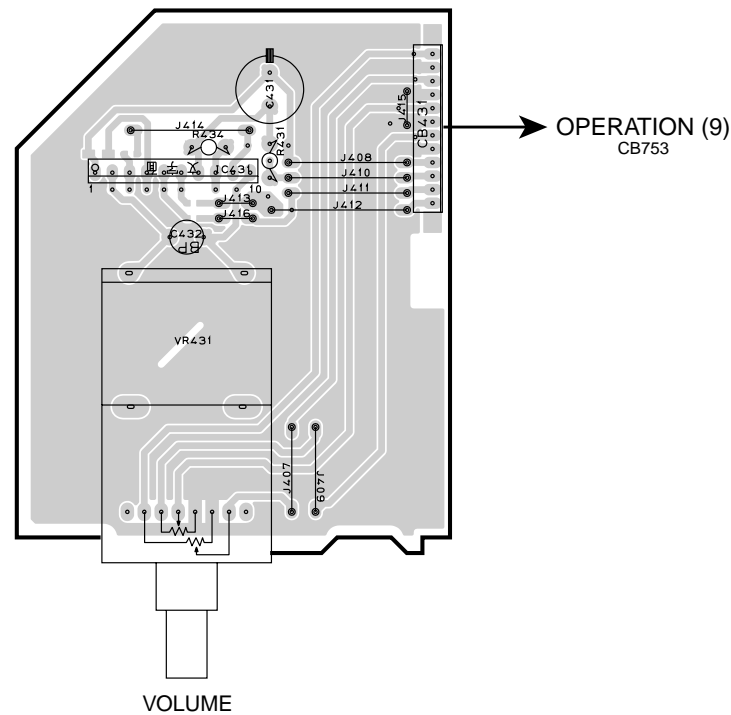

OPERATION (4) P.C.B. (Side B) Lead Free Solder Used

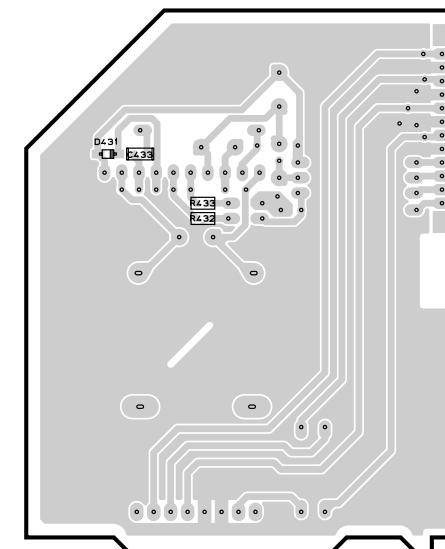

■ PRINTED CIRCUIT BOARD

1
2
3
4
5
6

OPERATION (5) P.C.B.

(Side A)

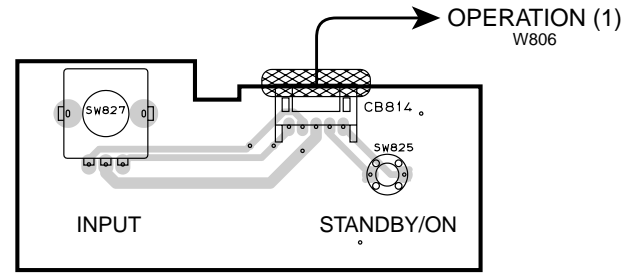

OPERATION (7) P.C.B.

(Side A)

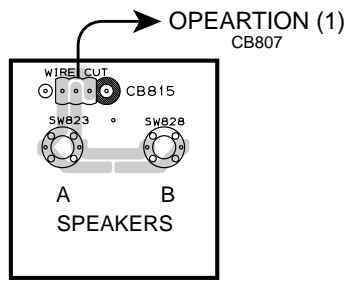

OPERATION (8) P.C.B.

(Side A)

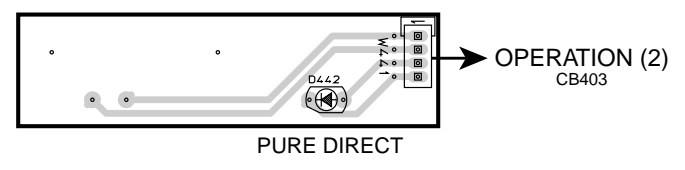

OPERATION (9) P.C.B.

(Side A)

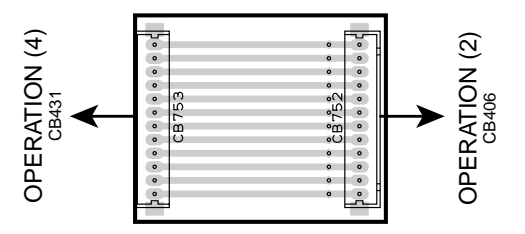

OPERATION (7) P.C.B.

(Side B) Lead Free Solder Used

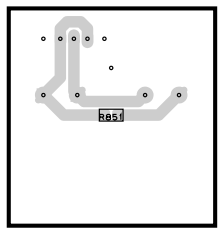

OPERATION (13) P.C.B.

(Side A)

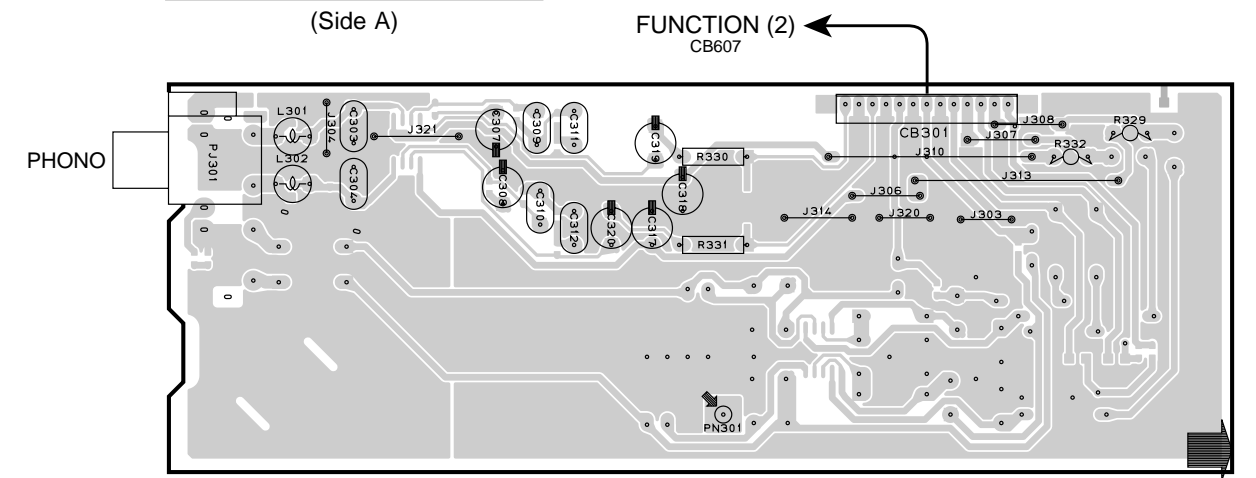

OPERATION (10) P.C.B.

(Side A)

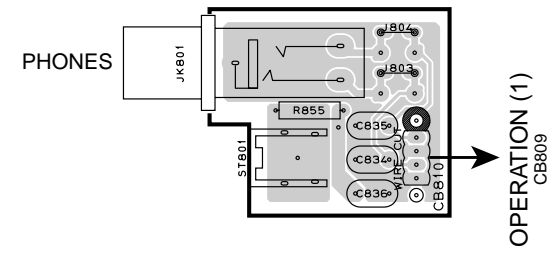

OPERATION (12) P.C.B.

(Side A)

A, G, E, L models

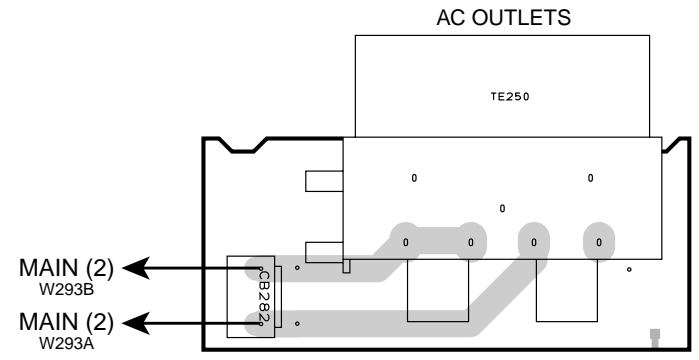

OPERATION (13) P.C.B.

(Side B) Lead Free Solder Used

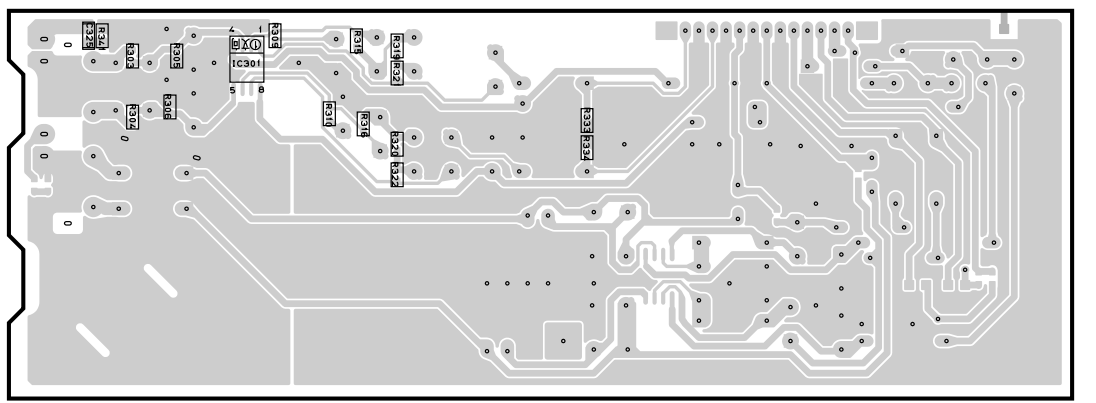

PRINTED CIRCUIT BOARD Lead Free Solder Used

MAIN (1) P.C.B.

(Side A)

MAIN (5) P.C.B.

(Side A)

MAIN (1)

Circuit No.	A, G, E, L	U, C, R
C156-159, 161, 162	O	X

X: NOT USED
O: USED/APPLICABLE

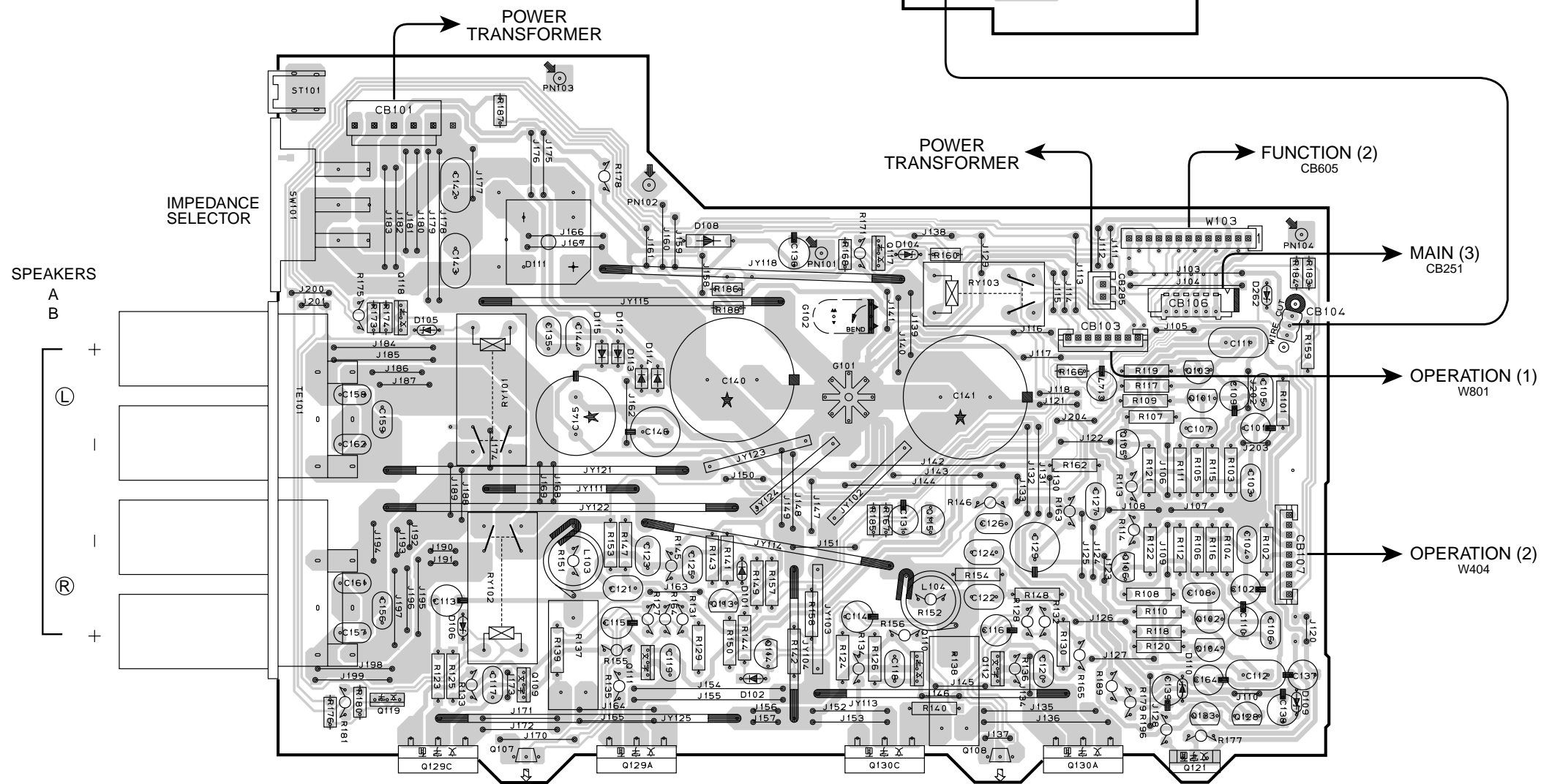

1
2
3
4
5
6

PRINTED CIRCUIT BOARD Lead Free Solder Used

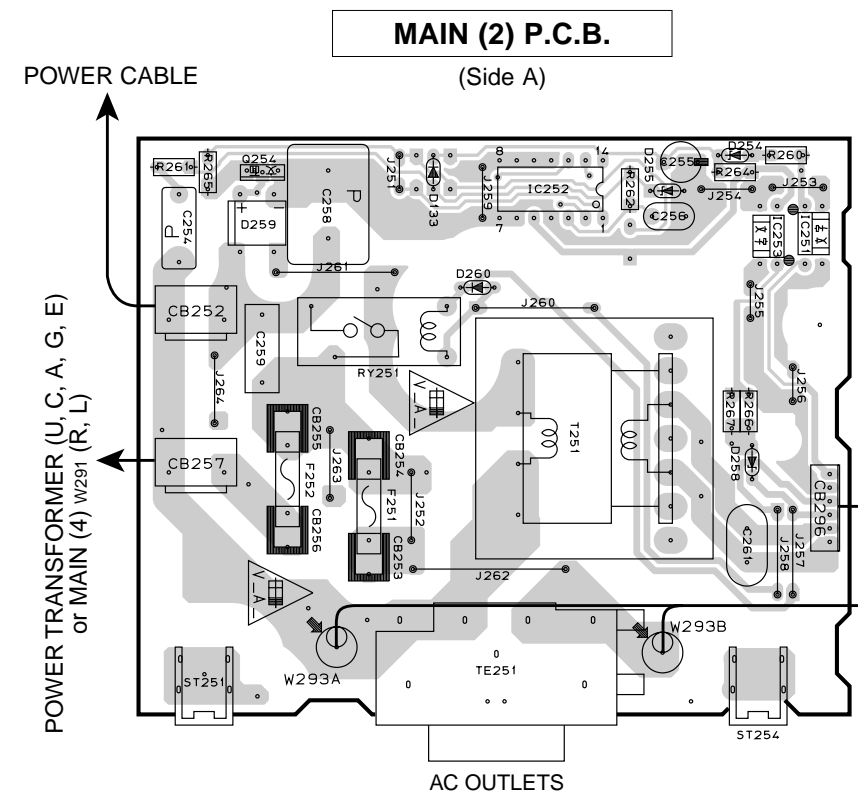

MAIN (2)

Circuit No.	U, C	R	A	G, E	L
J252	X	O	O	X	O
CB253, 254	O	X	X	O	X
F251	O	X	X	O	X
TE251	O	O	X	X	X
W293	X	X	O	O	O
ST254	X	X	O	O	O

X: NOT USED
O: USED/APPLICABLE

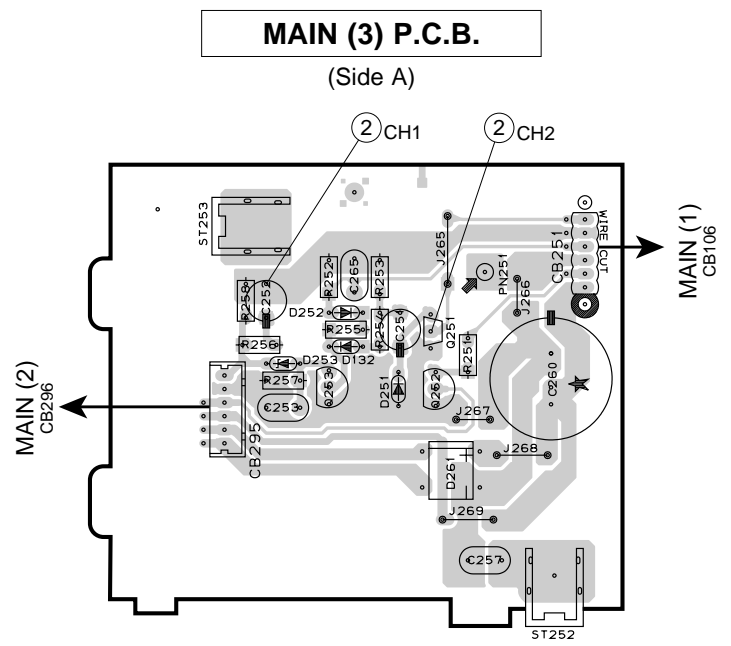

Point ②
 CH 1 : (+) of C252
 CH 2 : Collector of Q251

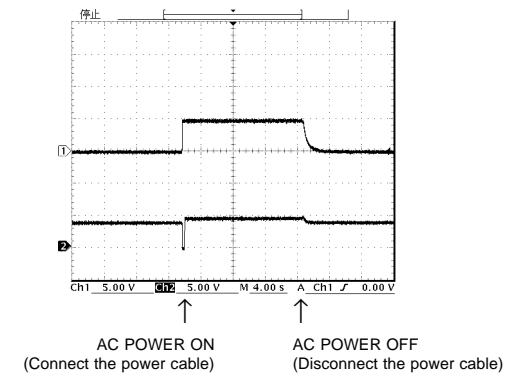

MAIN (4) P.C.B. (Side A)
 R, L models

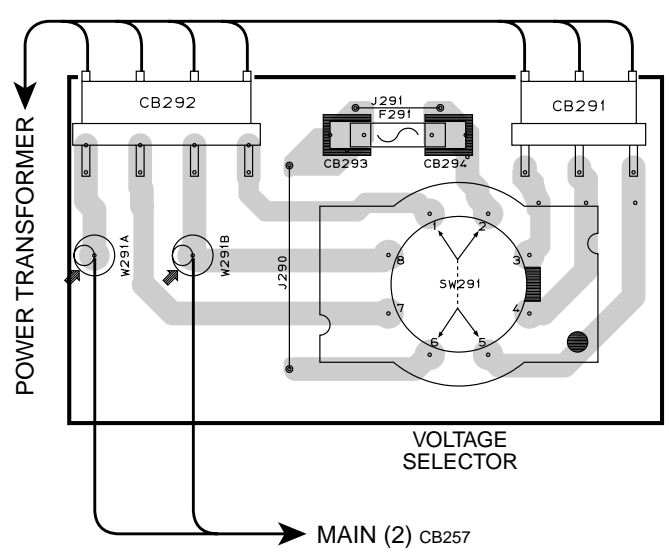

MAIN (4)

Circuit No.	R	L
CB293, 294	O	X
F291	O	X
J291	X	O

X: NOT USED
O: USED/APPLICABLE

VOLTAGE SELECTOR SW291

240V	1-2/5-6
220V	2-3/6-7
110V	3-4/7-8
120V	4-5/8-1

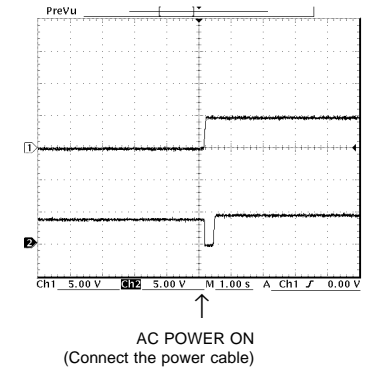

■ BLOCK DIAGRAM

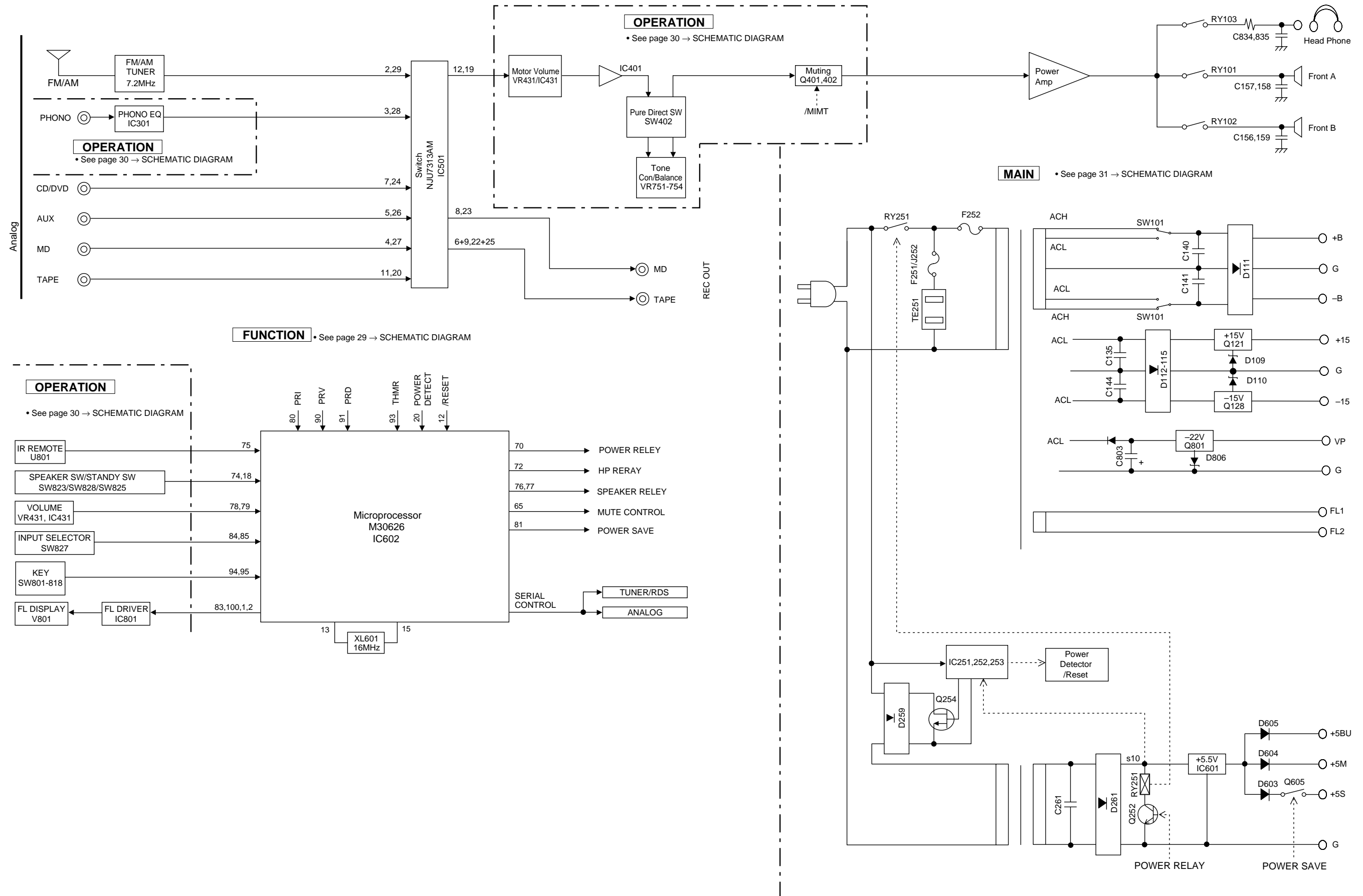

SCHEMATIC DIAGRAM (FUNCTION)

NOTICE (mode1)
(U)..... U.S.A
(C)..... CANADA
(R)..... GENERAL
(T)..... CHINA
(K)..... KOREA
(A)..... AUSTRALIA
(B)..... BRITISH
(G)..... EUROPE
(L)..... SINGAPORE
(E)..... SOUTH EUROPE
(V)..... TAIWAN

Table with 2 columns: REMARKS, PARTS NAME. Lists various resistor types like CARBON FILM RESISTOR, METAL OXIDE FILM RESISTOR, etc.

Table with 2 columns: REMARKS, PARTS NAME. Lists various capacitor types like ELECTROLYTIC CAPACITOR, TANTALUM CAPACITOR, etc.

Table with 6 columns: Mark, Reference Parts Number, Parts Name, and others. Lists interchangeable parts at manufacture-stage.

Table with 3 columns: Mark, Reference Parts Number, Parts Name. Lists interchangeable parts at manufacture-stage.

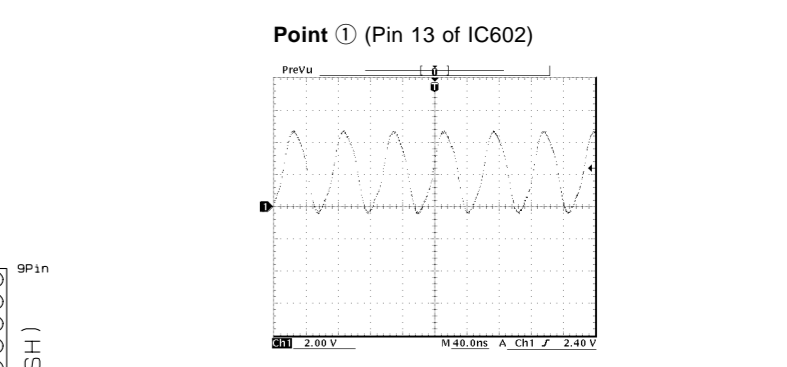
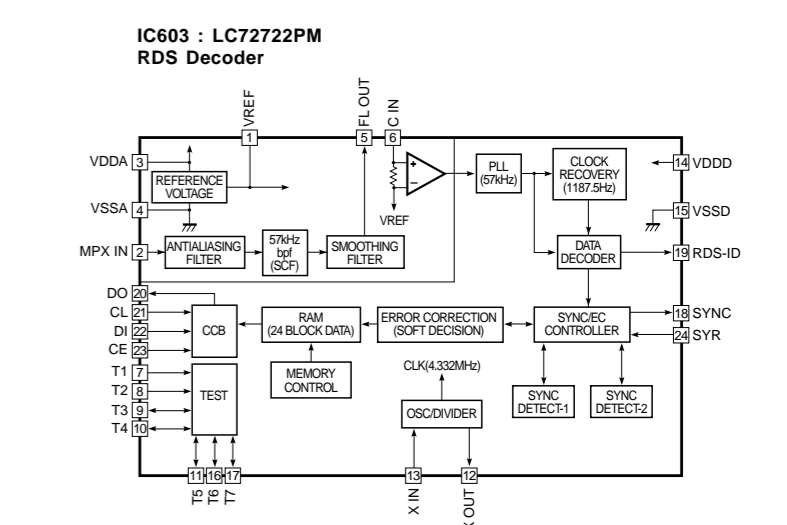

* All voltages are measured with a 10MΩ/V DC electronic volt meter.
* Components having special characteristics are marked Δ, and must be replaced with parts having specifications equal to those originally installed.
* Schematic diagram is subject to change without notice.

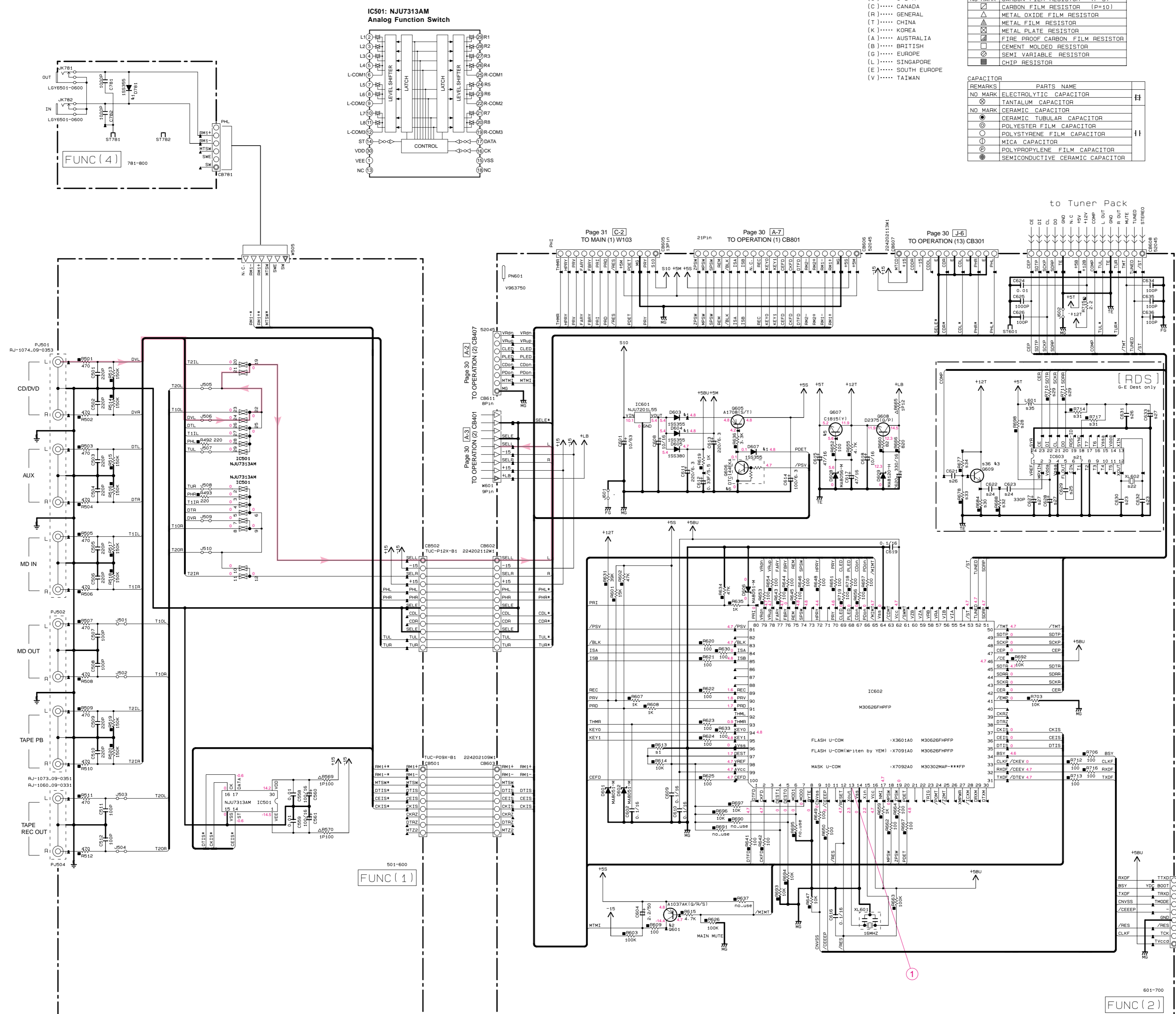

1
2
3
4
5
6
7
8

601-700
FUNC (2)

SCHEMATIC DIAGRAM (OPERATION)

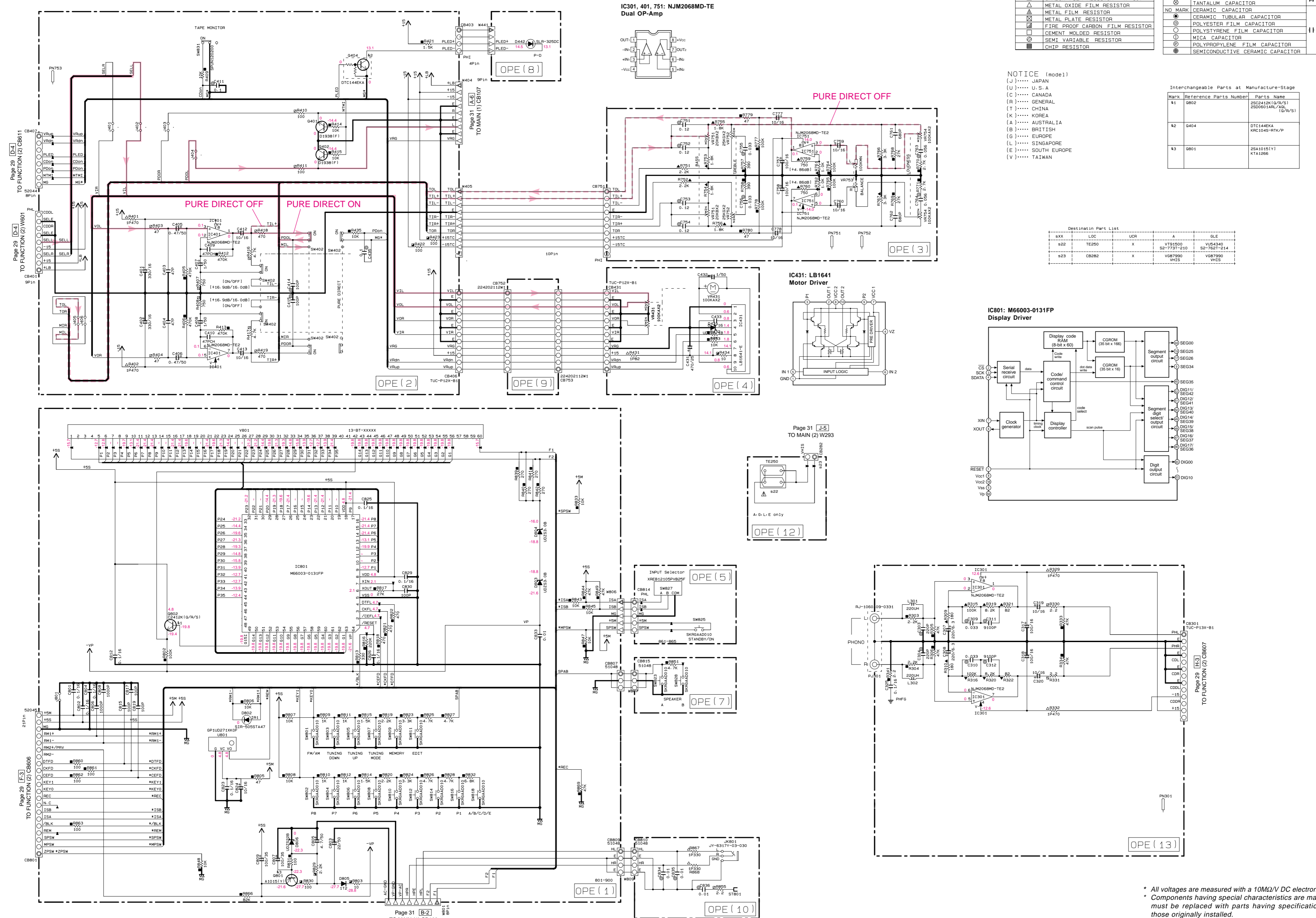

RESISTOR		CAPACITOR	
REMARKS	PARTS NAME	REMARKS	PARTS NAME
NO MARK	CARBON FILM RESISTOR (P=5)	NO MARK	ELECTROLYTIC CAPACITOR
△	CARBON FILM RESISTOR (P=10)	⊗	TANTALUM CAPACITOR
□	METAL OXIDE FILM RESISTOR	⊙	CERAMIC CAPACITOR
▲	METAL FILM RESISTOR	○	CERAMIC TUBULAR CAPACITOR
△	METAL PLATE RESISTOR	○	POLYESTER FILM CAPACITOR
□	FIRE PROOF CARBON FILM RESISTOR	○	POLYSTYRENE FILM CAPACITOR
□	CEMENT MOLDED RESISTOR	○	MICA CAPACITOR
□	SEMI VARIABLE RESISTOR	○	POLYPROPYLENE FILM CAPACITOR
■	CHIP RESISTOR	○	SEMICONDUCTIVE CERAMIC CAPACITOR

NOTICE (model)

(J)..... JAPAN
 (U)..... U.S.A
 (C)..... CANADA
 (R)..... GENERAL
 (T)..... CHINA
 (K)..... KOREA
 (A)..... AUSTRALIA
 (B)..... BRITISH
 (G)..... EUROPE
 (L)..... SINGAPORE
 (E)..... SOUTH EUROPE
 (V)..... TAIWAN

Interchangeable Parts at Manufacture-Stage

Mark	Reference Parts Number	Parts Name
△1	0802	2SC2412K (I/R/S) 2SD0601AR (A/R/S) (I/R/S)
△2	0404	DTC144EKA KRC1045-RTK/P
△3	0801	2SA10151Y1 KTA1266

Destination Part List

SXX	LOC	UCR	A	GLE
920	TE250	X	V91500 S2-7731-210	VU54340 S2-7521-214
923	CB282	X	V687990 VW15	V687990 VW15

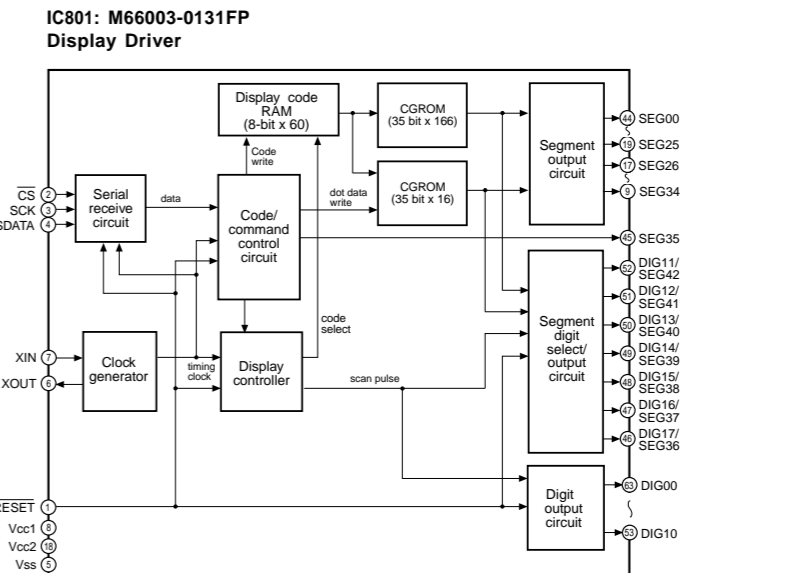

* All voltages are measured with a 10MΩ/V DC electronic volt meter.
 * Components having special characteristics are marked △ and must be replaced with parts having specifications equal to those originally installed.
 * Schematic diagram is subject to change without notice.

SCHEMATIC DIAGRAM (MAIN)

NOTICE [mode1]
(J)..... JAPAN
(U)..... U. S. A
(C)..... CANADA
(R)..... GENERAL
(T)..... CHINA
(K)..... KOREA
(A)..... AUSTRALIA
(B)..... BRITISH
(G)..... EUROPE
(L)..... SINGAPORE
(E)..... SOUTH EUROPE
(V)..... TAIWAN

Table with 2 columns: REMARKS, PARTS NAME. Lists resistor types like CARBON FILM RESISTOR, METAL OXIDE FILM RESISTOR, etc.

Table with 7 columns: Reference No, U-C, R, A, B, G-E, L. Lists various electronic components and their specifications.

Table with 2 columns: REMARKS, PARTS NAME. Lists capacitor types like ELECTROLYTIC CAPACITOR, TANTALUM CAPACITOR, etc.

Table with 2 columns: Mark, Reference Parts Number, Parts Name. Lists interchangeable parts for the main circuit.

Point ②
CH 1 : (+) of C252
CH 2 : Collector of Q251

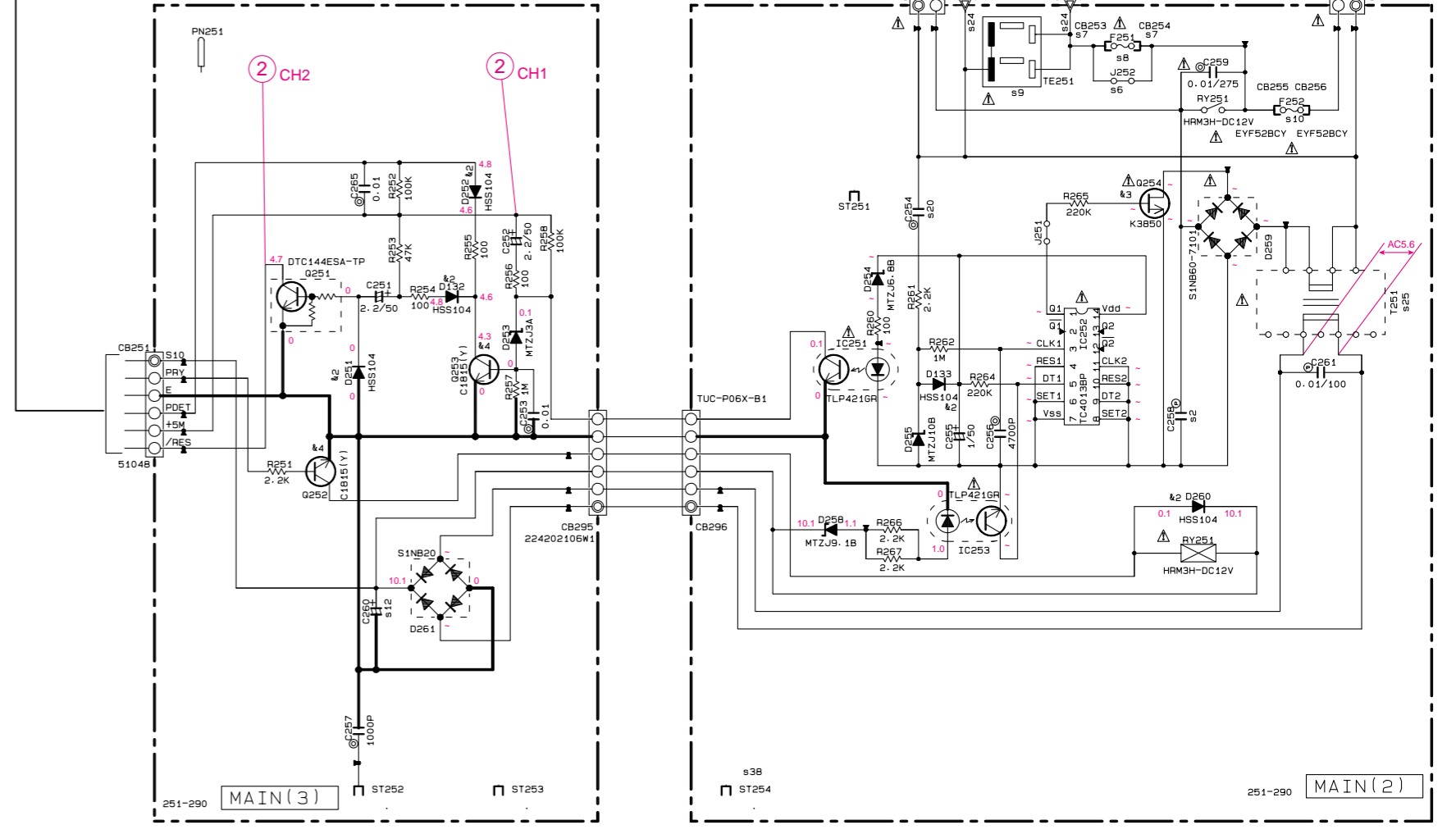
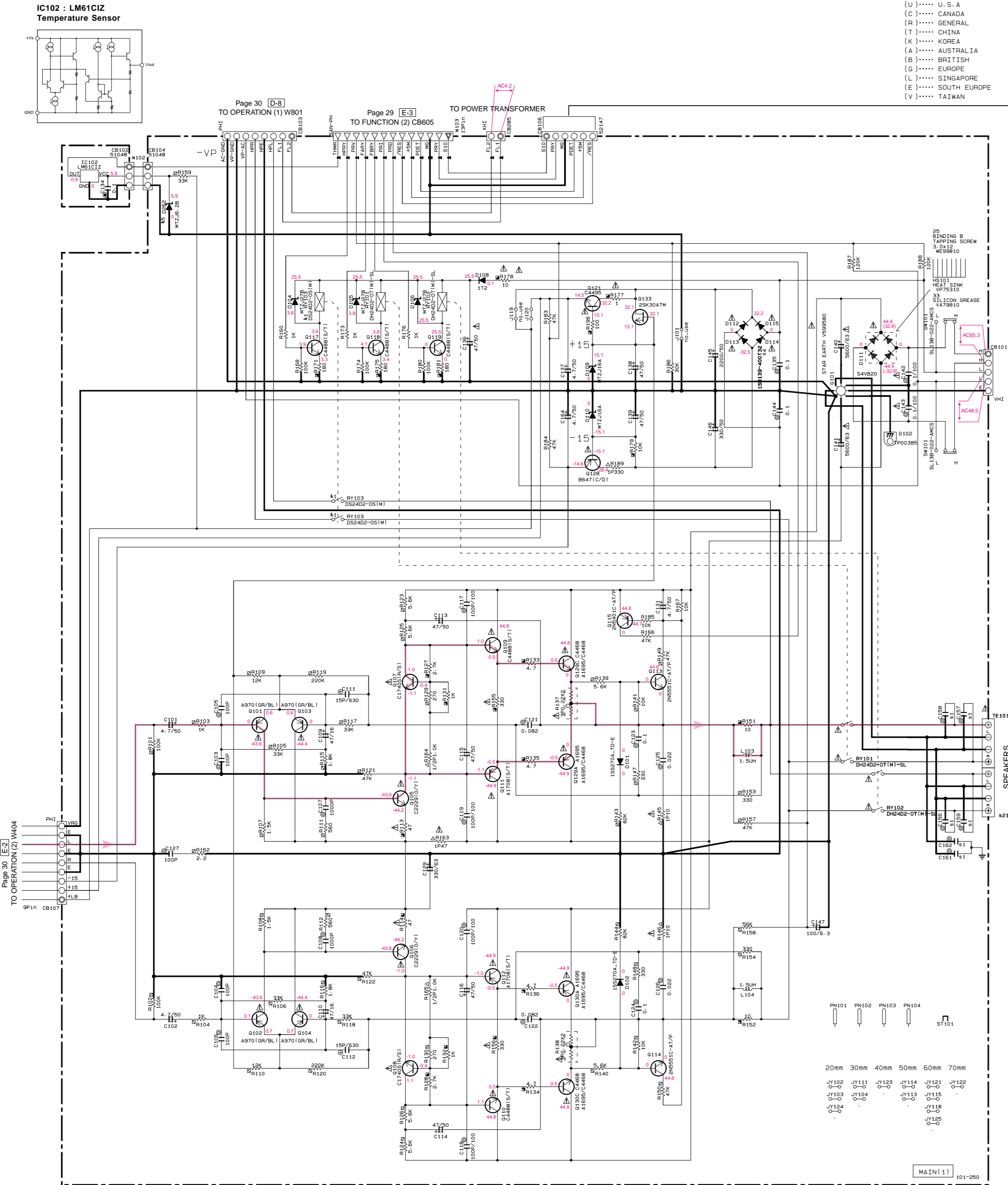
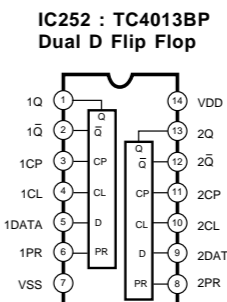
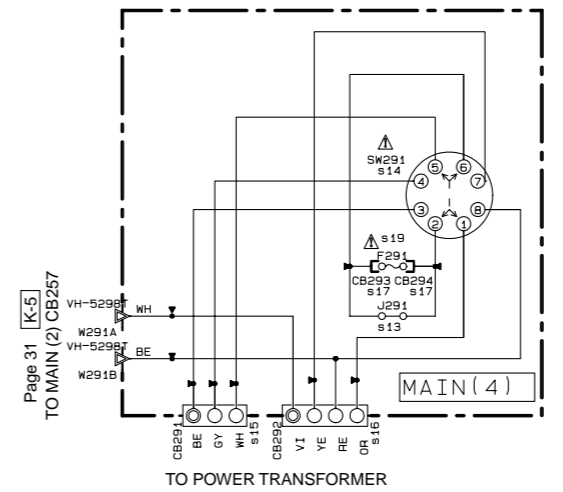
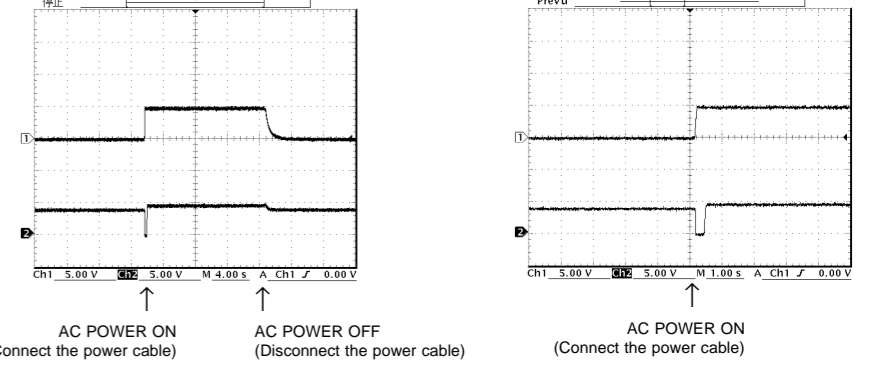

* All voltages are measured with a 10MΩ/V DC electronic volt meter.
* Components having special characteristics are marked Δ and must be replaced with parts having specifications equal to those originally installed.
* Schematic diagram is subject to change without notice.

REMOTE CONTROL RAX16

■ SCHEMATIC DIAGRAM

KEY NO. LAYOUT

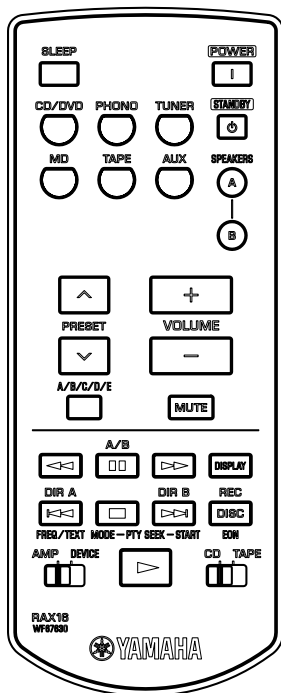
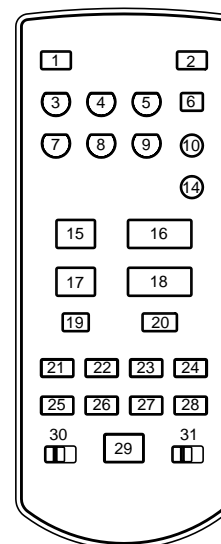
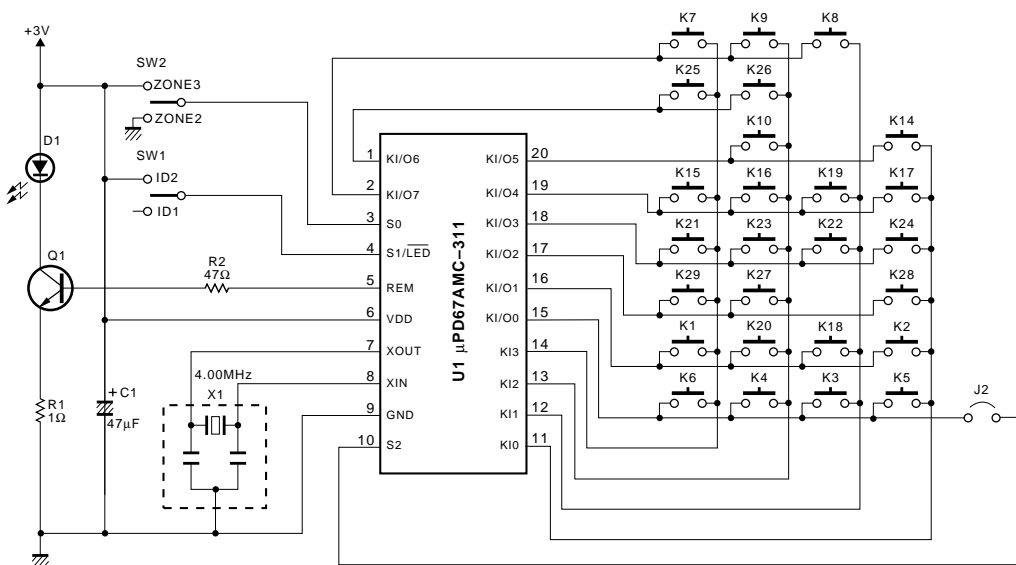

YAMAHA RAX16 IR CODE TABLE

Key No.	Key Name	Code (ID2)			
		AMP (RDS)	CD	DEVICE	
1	SLEEP		7D-93		
2	POWER		7D-B2		
3	CD/DVD		7D-87		
4	PHONO		7D-88		
5	TUNER		7D-89		
6	STANDBY		7D-B1		
7	MD		7D-86		
8	TAPE		7D-8B		
9	AUX		7D-8A		
10	SPEAKERS-A		7D-E7		
11	(no key)		(no code)		
12	(no key)		(no code)		
13	(no key)		(no code)		
14	SPEAKERS-B		7D-E8		
15	PRESET (+)		7D-F5		
16	VOLUME (+)		7D-8D		
17	PRESET (-)		7D-F6		
18	VOLUME (-)		7D-8E		
19	A/B/C/D/E		7D-F7		
20	MUTE		7D-94		
21	Device	(no code)	REW	7A-0D	REW 7A-01
22	Device	(no code)	PAUSE	7A-09	A/B 7A-06
23	Device	(no code)	FF	7A-0C	FF 7A-02
24	Device	(no code)	DISPLAY	79-0A	(no code)
25	Device	FREQ/TEXT	7D-23	SKIP (-)	7A-0B DIR A 7A-07
26	Device	MODE-PTY	7D-25	STOP	7A-09 STOP 7A-03
27	Device	SEEK-START	7D-26	SKIP (+)	7A-0A DIR B 7A-40
28	Device	EON	7D-24	DISC SKIP	7A-4F REC 7A-04
29	Device	(no code)	PLAY	7A-08	PLAY 7A-00
30	AMP/DEVICE				
31	CD/TAPE				

PARTS LIST

■ ELECTRICAL PARTS

■ WARNING

Components having special characteristics are marked \triangle and must be replaced with parts having specifications equal to those originally installed.

ABBREVIATIONS IN THIS LIST ARE AS FOLLOWS :

C.A.EL.CHP	: CHIP ALUMI. ELECTROLYTIC CAP	L.EMIT	: LIGHT EMITTING MODULE
C.CE	: CERAMIC CAP	LED.DSPLY	: LED DISPLAY
C.CE.ARRAY	: CERAMIC CAP ARRAY	LED.INFRD	: LED, INFRARED
C.CE.CHP	: CHIP CERAMIC CAP	MODUL.RF	: MODULATOR, RF
C.CE.ML	: MULTILAYER CERAMIC CAP	PHOT.CPL	: PHOTO COUPLER
C.CE.M.CHP	: CHIP MULTILAYER CERAMIC CAP	PHOT.INTR	: PHOTO INTERRUPTER
C.CE.SAFTY	: RECOGNIZED CERAMIC CAP	PHOT.RFLCT	: PHOTO REFLECTOR
C.CE.TUBLR	: CERAMIC TUBULAR CAP	PIN.TEST	: PIN, TEST POINT
C.CE.SMI	: SEMI CONDUCTIVE CERAMIC CAP	PLST.RIVET	: PLASTIC RIVET
C.EL	: ELECTROLYTIC CAP	R.ARRAY	: RESISTOR ARRAY
C.MICA	: MICA CAP	R.CAR	: CARBON RESISTOR
C.ML.FLM	: MULTILAYER FILM CAP	R.CAR.CHP	: CHIP RESISTOR
C.MP	: METALLIZED PAPER CAP	R.CAR.FP	: FLAME PROOF CARBON RESISTOR
C.MYLAR	: MYLAR FILM CAP	R.CEMENT	: CEMENT RESISTOR
C.MYLAR.ML	: MULTILAYER MYLAR FILM CAP	R.FUS	: FUSABLE RESISTOR
C.PAPER	: PAPER CAPACITOR	R.MTL.CHP	: CHIP METAL FILM RESISTOR
C.PLS	: POLYSTYRENE FILM CAP	R.MTL.FLM	: METAL FILM RESISTOR
C.POL	: POLYESTER FILM CAP	R.MTL.OXD	: METAL OXIDE FILM RESISTOR
C.POLY	: POLYETHYLENE FILM CAP	R.MTL.PLAT	: METAL PLATE RESISTOR
C.PP	: POLYPROPYLENE FILM CAP	RSNR.CE	: CERAMIC RESONATOR
C.TNTL	: TANTALUM CAP	RSNR.CRYS	: CRYSTAL RESONATOR
C.TNTL.CHP	: CHIP TANTALUM CAP	R.TW.CEM	: TWIN CEMENT FIXED RESISTOR
C.TRIM	: TRIMMER CAP	SCR.BND.HD	: BIND HEAD B-TITE SCREW
CN	: CONNECTOR	SCR.BW.HD	: BW HEAD TAPPING SCREW
CN.BS.PIN	: CONNECTOR, BASE PIN	SCR.CUP	: CUP TITE SCREW
CN.CANNON	: CONNECTOR, CANNON	SCR.TERM	: SCREW TERMINAL
CN.DIN	: CONNECTOR, DIN	SCR.TR	: SCREW, TRANSISTOR
CN.FLAT	: CONNECTOR, FLAT CABLE	SUPRT.PCB	: SUPPORT, P.C.B.
CN.POST	: CONNECTOR, BASE POST	SURG.PRTCT	: SURGE PROTECTOR
COIL.MX.AM	: COIL, AM MIX	SW.TACT	: TACT SWITCH
COIL.AT.FM	: COIL, FM ANTENNA	SW.LEAF	: LEAF SWITCH
COIL.DT.FM	: COIL, FM DETECT	SW.LEVER	: LEVER SWITCH
COIL.MX.FM	: COIL, FM MIX	SW.MICRO	: MICRO SWITCH
COIL.OUTPT	: OUTPUT COIL	SW.PUSH	: PUSH SWITCH
DIOD.ARRAY	: DIODE ARRAY	SW.RT.ENC	: ROTARY ENCODER
DIODE.BRG	: DIODE BRIDGE	SW.RT.MTR	: ROTARY SWITCH WITH MOTOR
DIODE.CHP	: CHIP DIODE	SW.RT	: ROTARY SWITCH
DIODE.SHOT	: SCHOTTKY BARRIER DIODE	SW.SLIDE	: SLIDE SWITCH
DIODE.VAR	: VARACTOR DIODE	TERM.SP	: SPEAKER TERMINAL
DIOD.Z.CHP	: CHIP ZENER DIODE	TERM.WRAP	: WRAPPING TERMINAL
DIODE.ZENR	: ZENER DIODE	THRMST.CHP	: CHIP THERMISTOR
DSCR.CE	: CERAMIC DISCRIMINATOR	TR.CHP	: CHIP TRANSISTOR
FER.BEAD	: FERRITE BEADS	TR.DGT	: DIGITAL TRANSISTOR
FER.CORE	: FERRITE CORE	TR.DGT.CHP	: CHIP DIGITAL TRANSISTOR
FET.CHP	: CHIP FET	TRANS	: TRANSFORMER
FL.DSPLY	: FLUORESCENT DISPLAY	TRANS.PULS	: PULSE TRANSFORMER
FLTR.CE	: CERAMIC FILTER	TRANS.PWR	: POWER TRANSFORMER ASS'y
FLTR.COMB	: COMB FILTER MODULE	TUNER.AM	: TUNER PACK, AM
FLTR.LC.RF	: LC FILTER, EMI	TUNER.FM	: TUNER PACK, FM
GND.MTL	: GROUND PLATE	TUNER.PK	: FRONT-END TUNER PACK
GND.TERM	: GROUND TERMINAL	VR	: ROTARY POTENTIOMETER
HOLDER.FUS	: FUSE HOLDER	VR.MTR	: POTENTIOMETER WITH MOTOR
IC.PRTCT	: IC PROTECTOR	VR.SW	: POTENTIOMETER WITH ROTARY SW
JUMPER.CN	: JUMPER CONNECTOR	VR.SLIDE	: SLIDE POTENTIOMETER
JUMPER.TST	: JUMPER, TEST POINT	VR.TRIM	: TRIMMER POTENTIOMETER
L.DTCT	: LIGHT DETECTING MODULE		

Note) Those parts marked with “#” are not included in the P.C.B. ass'y.

P.C.B. FUNCTION & OPERATION
--

Ref No.	Part No.	Description	Market
*	WG054100	P. C. B.	UC
*	WG054200	P. C. B.	RL
*	WG054300	P. C. B.	A
*	WG054400	P. C. B.	GE
CB501	V7827600	SOCKET	9P SE TUC SERIES
CB502	V7827900	SOCKET	12P TE TUC SERIES
CB602	V7826200	CN	12P TE TUC SERIES
CB603	V7825900	CN	9P TE TUC SERIES
CB605	VF283100	CN.BS.PIN	13P
CB606	VQ047600	CN.BS.PIN	21P
CB607	V7826300	CN	13P TE TUC SERIES
CB608	VM859600	CN.BS.PIN	15P
CB610	VQ044400	CN.BS.PIN	9P
CB611	VP682200	CN.BS.PIN	8P
CB781	VB858500	CN.BS.PIN	6P
C501-506	US062220	C. CE. CHP	220pF 50V B
C507-508	US062100	C. CE. CHP	100pF 50V B
C509-510	US062220	C. CE. CHP	220pF 50V B
C511-512	US062100	C. CE. CHP	100pF 50V B
C558-559	US064100	C. CE. CHP	0.01uF 50V B
C560-561	UR838100	C. EL	100uF 16V
C601	UR877100	C. EL	10uF 63V
C602	US135100	C. CE. CHP	0.1uF 16V
C604	UR866220	C. EL	2.2uF 50V
C608	UR837100	C. EL	10uF 16V
C609-610	US135100	C. CE. CHP	0.1uF 16V
C611	UR818220	C. EL	220uF 6.3V
C612	WB165500	C. EL	0.33F 5.5V
C613	UR818220	C. EL	220uF 6.3V
C614	UR818100	C. EL	100uF 6.3V
C615	UR837470	C. EL	47uF 16V
C616	US135100	C. CE. CHP	0.1uF 16V
C617	UR837470	C. EL	47uF 16V
C618	UR837100	C. EL	10uF 16V
C619	US135100	C. CE. CHP	0.1uF 16V
C620	UR838330	C. EL	330uF 16V
C621	US135100	C. CE. CHP	0.1uF 16V
C622-623	US062330	C. CE. CHP	330pF 50V B
C624	US064100	C. CE. CHP	0.01uF 50V B
C625	US063100	C. CE. CHP	1000pF 50V B
C626	US062100	C. CE. CHP	100pF 50V B
C627-628	UR837470	C. EL	47uF 16V
C629	US062560	C. CE. CHP	560pF 50V B
C630	US061270	C. CE. CHP	27pF 50V B
C631	US135100	C. CE. CHP	0.1uF 16V
C632	US061270	C. CE. CHP	27pF 50V B
C633	UR837470	C. EL	47uF 16V
C634-636	US062100	C. CE. CHP	100pF 50V B
C781-782	US063100	C. CE. CHP	1000pF 50V B
D601-602	VU992600	DIODE.ZENR	MA8051-M 5.1V
D603-604	VT332900	DIODE	1SS355
D605	VV833200	DIODE	1SS380
D606	VU992600	DIODE.ZENR	MA8051-M 5.1V

* New Parts

Ref No.	Part No.	Description	Market
D607	VT332900	DIODE	1SS355
D608	VU993000	DIODE.ZENR	MA8056-M 5.6V
D609	VU996300	DIODE.ZENR	MA8120-H 12.3V
D781	VT332900	DIODE	1SS355
IC501	X5043A00	IC	NJU7313AM
IC601	X5041A00	IC	NJU7201L55 5.5V
* IC602	X7092A00	IC.CPU	CPU MASK ROM
IC603	X0082A00	IC	LC72722PM
JK781-782	VJ726800	JACK.MNI	LGY6501-0600C
* PJ501	WD195400	JACK.PIN	6P
PJ502	WD195200	JACK.PIN	4P
* PJ504	WD195100	JACK.PIN	2P
PN601	V9637500	PIN	L=70 #18
Q601	VV556500	TR	2SA1037K Q,R,S
Q605	VP872600	TR	2SA1708 S,T
Q606	VV655700	TR.DGT	DTC144EKA
Q607	iC181510	TR	2SC1815 Y
Q608	VS826900	TR	2SD2375 Q,P
Q609	iC174020	TR	2SC1740S QRS
R569-570	VP940400	R.MTL.OXD	100 1W
R613		R.CHP	33K 1/16W J UC
R613		R.CHP	68K 1/16W J RL
R613		R.CHP	120K 1/16W J A
R665	VY893200	R.MTL.OXD	12 1W
R677		R.CHP	100K 1/16W J GE
R678		R.CHP	33K 1/16W J GE
R684		R.CHP	3.3K 1/16W J GE
R688		R.CHP	22K 1/16W J GE
R698		R.CHP	100 1/16W J GE
R710-711		R.CHP	470 1/16W J GE
R714		R.CHP	10K 1/16W J GE
R715	HV753220	R.CAR.FP	2.2 1/4W
R717		R.CHP	10K 1/16W J GE
ST601	V4040500	SCR.TERM	M3
ST781-782	V4040500	SCR.TERM	M3
XL601	WA674700	RSNR.CE	16MHz CSTLS16MOX51
XL602	V3930900	RSNR.CRYS	4.332MHz
*	WG054900	P. C. B.	OPERATION UCR
*	WG055000	P. C. B.	OPERATION A
*	WG055100	P. C. B.	OPERATION GEL
CB282	VG879900	CN.BS.PIN	2P
CB301	V7828000	SOCKET	13P SE TUC SERIES
CB401	VB858800	CN.BS.PIN	9P
CB403	VB390000	CN.BS.PIN	4P
CB406	V7827900	SOCKET	12P TE TUC SERIES
CB407	VP682300	CN.BS.PIN	8P
CB431	V7827900	SOCKET	12P TE TUC SERIES
CB751	VB390600	CN.BS.PIN	10P
CB752-753	V7826200	CN	12P TE TUC SERIES
CB801	VQ047600	CN.BS.PIN	21P

* New Parts

P.C.B. OPERATION

Ref No.	Part No.	Description	Market
CB814	VB858400	CN. BS . PIN	5P
C303-304	UA652220	C. MYLAR	220pF 50V J
C307-308	UU318220	C. EL	220uF 6.3V
C309-310	UA654330	C. MYLAR	0.033uF 50V J
C311-312	UA653910	C. MYLAR	9100pF 50V J
C317-318	UU338100	C. EL	100uF 16V
C319-320	UU337100	C. EL	10uF 16V
C325	US135100	C. CE. CHP	0.1uF 16V
C401-402	UU338330	C. EL	330uF 16V
C403-404	FG651470	C. CE	47pF 50V
C405-406	UU365470	C. EL	0.47uF 50V
* C407-408	UU366100	C. EL	1uF 50V
C409-410	US061470	C. CE. CHP	47pF 50V B
C411	UA655100	C. MYLAR	0.1uF 50V J
C412-413	UU337100	C. EL	10uF 16V
C414-415	UA652100	C. MYLAR	100pF 50V J
C431	UR848470	C. EL	470uF 25V
C432	UN866100	C. EL	1uF 50V
C433	US135100	C. CE. CHP	0.1uF 16V
C435	UA655100	C. MYLAR	0.1uF 50V J
C751-754	UA655120	C. MYLAR	0.12uF 50V J
C755-756	UA654330	C. MYLAR	0.033uF 50V J
C757-758	UU338100	C. EL	100uF 16V
C759-760	UU337100	C. EL	10uF 16V
C761-762	US062680	C. CE. CHP	680pF 50V B
C763-764	UA654560	C. MYLAR	0.056uF 50V J
C777-778	UU337100	C. EL	10uF 16V
C801-802	US135100	C. CE. CHP	0.1uF 16V
C803	UR867220	C. EL	22uF 50V
C804	US135100	C. CE. CHP	0.1uF 16V
C805	URO66470	C. EL	4.7uF 50V
C806	US063100	C. CE. CHP	1000pF 50V B
C807	URO58100	C. EL	100uF 35V
C808	US063100	C. CE. CHP	1000pF 50V B
C809	UR858100	C. EL	100uF 35V
C812	US135100	C. CE. CHP	0.1uF 16V
C815	US062100	C. CE. CHP	100pF 50V B
C817	US062100	C. CE. CHP	100pF 50V B
C819	US062100	C. CE. CHP	100pF 50V B
C823	US135100	C. CE. CHP	0.1uF 16V
C824	UM397100	C. EL	10uF 16V
C825-826	US135100	C. CE. CHP	0.1uF 16V
C829	US135100	C. CE. CHP	0.1uF 16V
C830	US062100	C. CE. CHP	100pF 50V B
C833	US064100	C. CE. CHP	0.01uF 50V B
C834-836	UA654100	C. MYLAR	0.01uF 50V J
D431	VU171900	DIODE. ZENR	UDZ5.1B 5.1V
D442	VR711500	LED(or)	SLR-325DC
D802	V2598200	LED	SIR-505ST
* D803-804	VU171300	DIODE. ZENR	UDZS3.0BTE-17 3.0V
D805	VS997800	DIODE	1T2
* D806	VU173400	DIODE. ZENR	UDZS22B TE-17 22V
IC301	X3505A00	IC	NJM2068MD-TE2

* New Parts

Ref No.	Part No.	Description	Market
IC401	X3505A00	IC	NJM2068MD-TE2
IC431	XF494A00	IC	LB1641
IC751	X3505A00	IC	NJM2068MD-TE2
IC801	X6386A00	IC	M66003-0131FP
JK801	V4478300	JACK. PHONE	JY-6317Y-03-030
* PJ301	WD195100	JACK. PIN	2P
PN301	V9637500	PIN	L=70 #18
PN751-753	V9637500	PIN	L=70 #18
Q401-402	VZ725900	TR	2SD1938F S,T
Q404	V655700	TR. DGT	DTC144EKA
Q801	iA101510	TR	2SA1015 Y
Q802	VV556400	TR	2SC2412K Q,R,S
R329	VP940800	R. MTL. OXD	470 1W
R332	VP940800	R. MTL. OXD	470 1W
R401-402	VP940800	R. MTL. OXD	470 1W
R422-423	HV755100	R. CAR. FP	100 1/4W
R431	VS267200	R. MTL. OXD	82 1W
R434	HV754100	R. CAR. FP	10 1/4W
R803	HV754100	R. CAR. FP	10 1/4W
R829	HV756220	R. CAR. FP	2.2K 1/4W
R830	HV755100	R. CAR. FP	100 1/4W
R867-868	VP940700	R. MTL. OXD	330 1W
ST801	V4040500	SCR. TERM	M3
SW402	VV399800	SW. PUSH	SPUN12
SW801-812	WD483100	SW. TACT	SKRGAAD010
SW814	WD483100	SW. TACT	SKRGAAD010
SW816	WD483100	SW. TACT	SKRGAAD010
SW818	WD483100	SW. TACT	SKRGAAD010
SW823	WD483100	SW. TACT	SKRGAAD010
SW825	WD483100	SW. TACT	SKRGAAD010
SW827	V9266400	SW. RT. ENC	XREB12105PVB25F
SW828	WD483100	SW. TACT	SKRGAAD010
SW831	V3573100	SW. PUSH	SPUN120200
TE250	VT915000	OUTLET. AC	1P
TE250	VU543400	OUTLET. AC	2P
TE250	VU543400	OUTLET. AC	2P
U801	V8210200	L. DTCT	GP1UD271XK
* V801	WF519900	FL. DSPLY	
VR431	VR710500	VR. MTR	A100K
VR751	VP741800	VR	B20K
VR752	VP741900	VR	G25K
VR753	VP742000	VR	MN100K
VR754	WF774500	VR	A100K
* WG083700		SHEET	
VR380100		SPACER	FL-T6

* New Parts

P.C.B. MAIN

Ref No.	Part No.	Description	Market
* * * * *	WG052800	P.C.B. MAIN	UC
	WG052900	P.C.B. MAIN	R
	WG053000	P.C.B. MAIN	A
	WG053100	P.C.B. MAIN	GE
	WG053200	P.C.B. MAIN	L
	CB101	LB932050 CN.BS.PIN	5P
	CB103	VB390400 CN.BS.PIN	8P
	CB106	VF728300 CN	6P
	CB107	VB390500 CN.BS.PIN	9P
△	CB252	VG879900 CN.BS.PIN	2P
	CB253-254	WC050700 CLIP.FUSE	EYF-52BCY
	CB255-256	WC050700 CLIP.FUSE	EYF-52BCY
△	CB257	VG879900 CN.BS.PIN	2P
	CB285	LB918020 CN.BS.PIN	2P
*	CB291	V9377800 CN.BS.PIN	3P SE VH SERIES
*	CB292	V9377900 CN.BS.PIN	4P SE VH SERIES
	CB293-294	WC050700 CLIP.FUSE	EYF-52BCY
	CB295	V7825600 CN	6P TE TUC SERIES
	CB296	V7827300 SOCKET	6P TE TUC SERIES
	C101-102	UR866470 C.EL	4.7uF 50V
	C103-106	UA652100 C.MYLAR	100pF 50V J
	C107-108	UA653100 C.MYLAR	1000pF 50V J
	C109-110	UR837470 C.EL	47uF 16V
	C111-112	WE100100 C.PP	15pF 630V
	C113-114	UR867470 C.EL	47uF 50V
	C115-116	UU367470 C.EL	47uF 50V
	C117-120	VR325000 C.MYLAR	100pF 100V
	C121-122	UA654820 C.MYLAR	0.082uF 50V J
	C123-124	UA655100 C.MYLAR	0.1uF 50V J
	C125-126	UA654220 C.MYLAR	0.022uF 50V J
	C127	UA652100 C.MYLAR	100pF 50V J
	C129	UR778330 C.EL	330uF 63V
	C131	UR866470 C.EL	4.7uF 50V
	C134	VJ599100 C.CE.TUBLR	0.1uF 50V
	C135	UA655100 C.MYLAR	0.1uF 50V J
△	C136	UR867470 C.EL	47uF 50V
	C137	UR866470 C.EL	4.7uF 50V
	C138-139	UR867470 C.EL	47uF 50V
△ *	C140-141	WG399700 C.EL	5600uF 56V
△	C142-143	VR324900 C.MYLAR	0.1uF 100V
	C144	UA655100 C.MYLAR	0.1uF 50V J
	C145	UR769220 C.EL	2200uF 50V
	C146	UR868330 C.EL	330uF 50V
	C147	UR818100 C.EL	100uF 6.3V
	C156-159	UA654100 C.MYLAR	0.01uF 50V J
	C161-162	UA654100 C.MYLAR	0.01uF 50V J
	C164	UR866470 C.EL	4.7uF 50V
	C251-252	UR866220 C.EL	2.2uF 50V
	C253	UA654100 C.MYLAR	0.01uF 50V J
*	C254	WD054200 C.POL.MTL	0.047uF 630V
	C254	WC041600 C.PP	0.022uF 630V
	C255	UM416100 C.EL	1uF 50V
	C256	UA653470 C.MYLAR	4700pF 50V J
	C257	UA653100 C.MYLAR	1000pF 50V J
	C258	WB696300 C.POL.MTL	0.1uF 400V
	C258	WF081500 C.PP	0.047uF 630V J
	C258	WF081500 C.PP	0.047uF 630V J
△	C259	V6185300 C.CE.SAFETY	0.01uF 275V
	C260	UR039330 C.EL	3300uF 16V
	C260	UR069330 C.EL	3300uF 50V
	C261	WE102900 C.PP	0.01uF 100V
	C265	UA654100 C.MYLAR	0.01uF 50V J
	D101-102	VN008700 DIODE	1SS270A
	D104-106	VG442900 DIODE.ZENR	MTZJ27B 27V
	D108	VS997800 DIODE	1T2
	D109-110	VG441000 DIODE.ZENR	MTZJ16A 16V
△	D111	iH001090 DIODE.BRG	S4VB20 2.6A 200V
△	D112-115	VU264100 DIODE	1SR139,400
	D132-133	VD631600 DIODE	1SS133,176
	D251-252	VD631600 DIODE	1SS133,176
	D253	VG435800 DIODE.ZENR	MTZJ3.0A 3.0V
	D254	VG438300 DIODE.ZENR	MTZJ6.8B 6.8V
	D255	VG439500 DIODE.ZENR	MTZJ10B 10V
	D258	VG439200 DIODE.ZENR	MTZJ9.1B 9.1V
△	D259	V4756800 DIODE	S1NB60 1.0A 600V
	D260	VD631600 DIODE	1SS133,176
	D261	VR253700 DIODE.BRG	S1NB20 1A 200V
	D262	VG438000 DIODE.ZENR	MTZJ6.2B 6.2V
△	F251	WG410400 FUSE	5A 125V
△	F251	VT942900 FUSE	T2.5A 250V
△	F252	WG410400 FUSE	5A 125V
△	F252	KB000690 FUSE	T2.5A 250V
△	F291	KB000690 FUSE	T2.5A 250V
	G101	V5995800 PLATE.GND	
	IC102	X0515A00 IC	LM61CIZ THERMAL
△	IC251	V8100500 PHOT.CPL	TLP421 GR
△	IC252	iG001180 IC	TC4013BP FF
△	IC253	V8100500 PHOT.CPL	TLP421 GR
	PN101-104	V9637500 PIN	L=70 #18
	PN251	V9637500 PIN	L=70 #18
△	Q101-104	iA097030 TR	2SA970 GR,BL
△	Q105-106	VR325600 TR	2SC2229 0,Y
△	Q107-108	iC174020 TR	2SC1740S QRS
△	Q109-110	VP872700 TR	2SC4488 S,T
△	Q111-112	VP872600 TR	2SA1708 S,T
	Q113-114	WC398400 TR	2SC2N5551C-AT
	Q115	WC397700 TR	2SA2N5401C-AT
	Q117-119	VP872700 TR	2SC4488 S,T
△	Q121	VN996900 TR	2SC4495
△	Q128	VR402300 TR	2SB647 C,D
△	Q129A	iX630850 TR	2SA1695 OPY
△	Q129C	iX630860 TR	2SC4468 OPY
△	Q130A	iX630850 TR	2SA1695 OPY
△	Q130C	iX630860 TR	2SC4468 OPY
*	Q133	WF730900 FET	2SK30ATM GR TP
	Q251	VV912300 TR.DGT	DTC144ESA-TP

* New Parts

* New Parts

P.C.B. MAIN & CHIP RESISTORS

Ref No.	Part No.	Description	Market
Q252-253	iC181510	TR	2SC1815 Y
△ Q254	WC741200	FET	2SK3850
△ R113-114	HV754470	R. CAR. FP	47 1/4W
R127-128	HV756270	R. CAR. FP	2.7K 1/4W
R131-132	HV756100	R. CAR. FP	1K 1/4W
R133-136	HV753470	R. CAR. FP	4.7 1/4W
△ R137-138	V3873200	R. CEMENT	0.22 3W
△ R145-146	VP939800	R. MTL. OXD	10 1W
R151-152	HV754100	R. CAR. FP	10 1/4W
△ R155-156	HV755330	R. CAR. FP	330 1/4W
△ R163	VP940200	R. MTL. OXD	47 1W
R164-165	HLO06100	R. MTL. OXD	1K 1/2W
R171	HV755180	R. CAR. FP	180 1/4W
R175	HV755180	R. CAR. FP	180 1/4W
△ R177	HV753100	R. CAR. FP	1 1/4W
△ R178	HV754100	R. CAR. FP	10 1/4W
R179	HV757100	R. CAR. FP	10K 1/4W
R181	HV755180	R. CAR. FP	180 1/4W
R189	VP940700	R. MTL. OXD	330 1W
R196	HV755100	R. CAR. FP	100 1/4W
△ RY101-102	V6322600	RELAY	DC DH24D2-OT(M)-SL
RY103	V5966300	RELAY	DS24D2-OS(M)
△ RY251	WE513800	RELAY	DC HRM3H-DC12V
ST101	V4040500	SCR. TERM	M3
ST251-254	V4040500	SCR. TERM	M3
ST254	V4040500	SCR. TERM	M3
SW101	V4104200	SW. SLIDE	SL13B-022-AMCS
△ * SW291	WB493700	VOLT. SELCT	R8140246
△ SW291	WD073700	VOLT. SELCT	R8140254
△ * T251	XW606A00	TRANS. PWR	
△ T251	X6351A00	TRANS. PWR	
△ * T251	XW608A00	TRANS. PWR	
△ TE101	VC313700	TERM. SP	8P
△ TE101	V4811400	TERM. SP	8P
△ TE251	VU543100	OUTLET. AC	2P
△ TE251	V5867400	OUTLET. AC	2P AC-182-GB-11V
*	WE998100	SCR. BND. HD	3x12 MFZN2B3

* New Parts

Ref No.	Part No.	Description	Market
		R. CHP	0 1/16W J
		R. CHP	2.2 1/16W J
		R. CHP	47 1/16W J
		R. CHP	82 1/16W J
		R. CHP	100 1/16W J
		R. CHP	220 1/16W J
		R. CHP	270 1/16W J
		R. CHP	330 1/16W J
		R. CHP	390 1/16W J
		R. CHP	470 1/16W J
		R. CHP	820 1/16W J
		R. CHP	1K 1/16W J
		R. CHP	1.5K 1/16W J
		R. CHP	2.2K 1/16W J
		R. CHP	2.7K 1/16W J
		R. CHP	3.3K 1/16W J
		R. CHP	4.7K 1/16W J
		R. CHP	6.8K 1/16W J
		R. CHP	10K 1/16W J
		R. CHP	15K 1/16W J
		R. CHP	22K 1/16W J
		R. CHP	27K 1/16W J
		R. CHP	33K 1/16W J
		R. CHP	39K 1/16W J
		R. CHP	47K 1/16W J
		R. CHP	68K 1/16W J
		R. CHP	82K 1/16W J
		R. CHP	100K 1/16W J
		R. CHP	120K 1/16W J
		R. CHP	150K 1/16W J
		R. CHP	220K 1/16W J
		R. CHP	470K 1/16W J
		R. MTL. CHP	82 1/16W D
		R. MTL. CHP	180 1/16W D
		R. MTL. CHP	750 1/16W D
		R. MTL. CHP	1.0K 1/16W D
		R. MTL. CHP	1.8K 1/16W D
		R. MTL. CHP	2.2K 1/16W D
		R. MTL. CHP	3.3K 1/16W D
		R. MTL. CHP	8.2K 1/16W D
		R. MTL. CHP	100K 1/16W D

NOTE

- The chip resistor is not supplied as a replacement part.
- When a chip resistor is necessary, use the following part.
AAX60720: CHIP RESISTOR SAMPLE BOOK

* New Parts

RX-397

Parts List for Carbon Resistors

Value	1/4W Type Part No.	1/6W Type Part No.	Value	1/4W Type Part No.	1/6W Type Part No.
1.0 Ω	HJ35 3100	HF85 3100	10 kΩ	HF45 7100	HF45 7100
1.8 Ω	HJ35 3180	*	11 kΩ	HF45 7110	HF45 7110
2.2 Ω	HJ35 3220	HF85 3220	12 kΩ	HJ35 7120	HF85 7120
3.3 Ω	HJ35 3330	HF85 3330	13 kΩ	HF45 7130	HF45 7130
4.7 Ω	HJ35 3470	HF85 3470	15 kΩ	HF45 7150	HF45 7150
5.6 Ω	HJ35 3560	HF85 3560	18 kΩ	HF45 7180	HF45 7180
10 Ω	HF45 4100	HF45 4100	22 kΩ	HF45 7220	HF45 7220
15 Ω	HJ35 4150	HF85 4150	24 kΩ	HF45 7240	HF45 7240
22 Ω	HF45 4220	HF45 4220	27 kΩ	HJ35 7270	HF85 7270
27 Ω	HJ35 4270	HF85 4270	30 kΩ	HF45 7300	HF45 7300
33 Ω	HF45 4330	HF45 4330	33 kΩ	HF45 7330	HF45 7330
39 Ω	HJ35 4470	HF85 4390	36 kΩ	HF45 7360	HF45 7360
47 Ω	HF45 4470	HF45 4470	39 kΩ	HF45 7390	HF45 7390
56 Ω	HF45 4560	HF45 4560	47 kΩ	HF45 7470	HF45 7470
68 Ω	HF45 4680	HF45 4680	51 kΩ	HF45 7510	HF45 7510
75 Ω	HF45 4750	HF45 4750	56 kΩ	HF45 7560	HF45 7560
82 Ω	HF45 4820	HF45 4820	62 kΩ	HF45 7620	HF45 7620
91 Ω	HF45 4910	HF45 4910	68 kΩ	HF45 7680	HF45 7680
100 Ω	HF45 5100	HF45 5100	82 kΩ	HF45 7820	HF45 7820
110 Ω	HJ35 5110	HF85 5110	91 kΩ	HF45 7910	HF45 7910
120 Ω	HF45 5120	HF45 5120	100 kΩ	HF45 8100	HF45 8100
150 Ω	HF45 5150	HF45 5150	110 kΩ	HF45 8110	HF45 8110
160 Ω	HJ35 5160	*	120 kΩ	HF45 8120	HF45 8120
180 Ω	HF45 5180	HF45 5180	150 kΩ	HF45 8150	HF45 8150
200 Ω	HF45 5200	HF45 5200	180 kΩ	HF45 8180	HF45 8180
220 Ω	HF45 5220	HF45 5220	220 kΩ	HJ35 8220	HF85 8220
270 Ω	HF45 5270	HF45 5270	270 kΩ	HF45 8270	HF45 8270
330 Ω	HF45 5330	HF45 5330	300 kΩ	HF45 8300	HF45 8300
390 Ω	HF45 5390	HF45 5390	330 kΩ	HF45 8330	HF45 8330
430 Ω	HF45 5430	HF45 5430	390 kΩ	HJ35 8390	HF85 8390
470 Ω	HF45 5470	HF45 5470	470 kΩ	HF45 8470	HF45 8470
510 Ω	HF45 5510	HF45 5510	560 kΩ	HJ35 8560	HF85 8560
560 Ω	HF45 5560	HF45 5560	680 kΩ	HJ35 8680	HF85 8680
680 Ω	HF45 5680	HF45 5680	820 kΩ	HJ35 8820	HF85 8820
820 Ω	HF45 5820	HF45 5820	1.0 MΩ	HF45 9100	HF45 9100
910 Ω	HF45 5910	HF45 5910	1.2 MΩ	HJ35 9120	*
1.0 kΩ	HF45 6100	HF45 6100	1.5 MΩ	HJ35 9150	HF85 9150
1.2 kΩ	HF45 6120	HF45 6120	1.8 MΩ	HJ35 9180	HF85 9180
1.5 kΩ	HF45 6150	HF45 6150	2.2 MΩ	HJ35 9220	HF85 9220
1.8 kΩ	HF45 6180	HF45 6180	3.3 MΩ	HJ35 9330	HF85 9330
2.0 kΩ	HJ35 6200	HF85 6200	3.9 MΩ	HJ35 9390	*
2.2 kΩ	HF45 6220	HF45 6220	4.7 MΩ	HJ35 9470	HF85 9470
2.4 kΩ	HJ35 6240	HF85 6240			
2.7 kΩ	HF45 6270	HF45 6270			
3.0 kΩ	HF45 6300	HF45 6300			
3.3 kΩ	HF45 6330	HF45 6330			
3.6 kΩ	HJ35 6360	HF85 6360			
3.9 kΩ	HF45 6390	HF45 6390			
4.7 kΩ	HF45 6470	HF45 6470			
5.1 kΩ	HF45 6510	HF45 6510			
5.6 kΩ	HF45 6560	HF45 6560			
6.8 kΩ	HF45 6680	HF45 6680			
8.2 kΩ	HF45 6820	HF45 6820			
9.1 kΩ	HF45 6910	HF45 6910			

1/4W Type

HJ35 ○○○○

10mm

1/6W Type

HF45 ○○○○

5mm

RX-397

EXPLODED VIEW

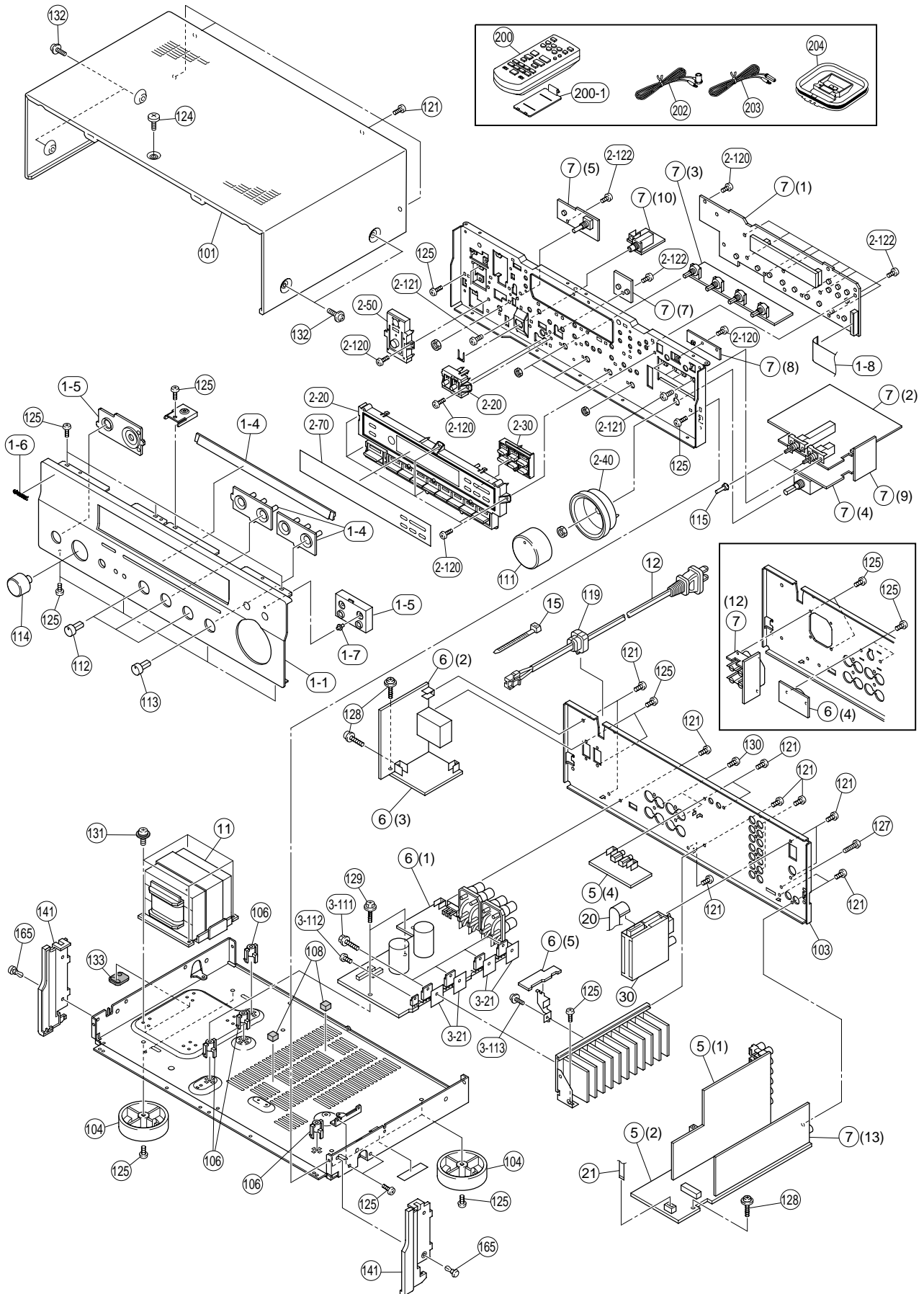

MECHANICAL PARTS

Ref. No.	Part No.	Description	Remarks	Markets
* 1-1	WF478400	FRONT PANEL		BL
* 1-1	WF478600	FRONT PANEL		TI
* 1-4	WF486800	ESCUTCHEON R		BL
* 1-4	WF487000	ESCUTCHEON R		TI
1-5	WF628900	ESCUTCHEON		BL
1-5	WF629100	ESCUTCHEON		TI
1-6	V6034100	EMBLEM		
1-7	V4598900	LENS, 1P		
* 1-8	MF121250	FLEXIBLE FLAT CABLE	21P 250mm P=1.25	
* 2-20	WF484100	BUTTON CASE		BL
* 2-20	WF484300	BUTTON CASE		TI
* 2-30	WF485100	BUTTON TUNER		
2-40	WF486500	ESCUTCHEON VOL		BL
2-40	WF486700	ESCUTCHEON VOL		TI
2-50	WF485300	BUTTON STANDBY		BL
2-50	WF485500	BUTTON STANDBY		TI
* 2-70	WF487900	SHEET WINDOW R		
2-120	WE774300	BIND HEAD B-TIGHT SCREW	3x8 MFZN2W3	
2-121	WE774000	BIND HEAD SCREW	3x6 MFZN2W3	
2-122	WE774800	BIND HEAD P-TIGHT SCREW	3x8 MFZN2W3	
3-21	VV849300	RADIATION SHEET	19x24	
3-111	VK173200	SCREW, TRANSISTOR	3x15 SP MFC2	
3-112	WE774300	BIND HEAD B-TIGHT SCREW	3x8 MFZN2W3	
3-113	VT669300	PW HEAD B-TIGHT SCREW	3x8-8 MFC2	
* 5	WG054100	P.C.B. ASS'Y	FUNCTION	UC
* 5	WG054200	P.C.B. ASS'Y	FUNCTION	RL
* 5	WG054300	P.C.B. ASS'Y	FUNCTION	A
* 5	WG054400	P.C.B. ASS'Y	FUNCTION	GE
* 6	WG052800	P.C.B. ASS'Y	MAIN	UC
* 6	WG052900	P.C.B. ASS'Y	MAIN	R
* 6	WG053000	P.C.B. ASS'Y	MAIN	A
* 6	WG053100	P.C.B. ASS'Y	MAIN	GE
* 6	WG053200	P.C.B. ASS'Y	MAIN	L
* 7	WG054900	P.C.B. ASS'Y	OPERATION	UCR
* 7	WG055000	P.C.B. ASS'Y	OPERATION	A
* 7	WG055100	P.C.B. ASS'Y	OPERATION	GEL
△* 11	X7069A00	POWER TRANSFORMER		UC
△* 11	X7070A00	POWER TRANSFORMER		RL
△* 11	X7071A00	POWER TRANSFORMER		A
△* 11	X7072A00	POWER TRANSFORMER		GE
△* 12	V2727500	POWER CABLE	2m	UC
△* 12	WC992700	POWER CABLE	2m	R
△* 12	WC743700	POWER CABLE	2m	A
△* 12	VN363600	POWER CABLE	2m	GEL
15	VU590000	BINDING TIE	CBTD001B	
20	MF115140	FLEXIBLE FLAT CABLE	15P 140mm P=1.25	
* 21	MF108160	FLEXIBLE FLAT CABLE	8P 160mm P=1.25	
30	V6782300	AM/FM TUNER	TFCE1U115A	UCRL
* 30	V6782400	AM/FM TUNER	TFCE1E317A	AGE
* 101	WF480500	TOP COVER		BL
* 101	WF480700	TOP COVER		TI
* 103	WF482200	REAR PANEL		UC
* 103	WF482300	REAR PANEL		R

* New Parts

Ref. No.	Part No.	Description	Remarks	Markets
* 103	WF482600	REAR PANEL		A
* 103	WF482700	REAR PANEL		L
* 103	WF482900	REAR PANEL		GE
104	VS025000	LEG	D60xH21	
106	VR264400	SPACER	H8	
108	VQ366100	DAMPER, PCB		
111	WF817400	KNOB D48		BL
111	WF817600	KNOB D48		TI
* 112	WF485600	KNOB		BL
* 112	WF485800	KNOB		TI
* 113	WF485900	KNOB D14L		BL
* 113	WF486100	KNOB D14L		TI
114	WC560500	KNOB D23		BL
114	WC560700	KNOB D23		TI
115	V6876100	BUTTON/D5		BL
115	V8540300	BUTTON/D5		TI
119	V2438700	CORD STOPPER	10P1	
121	WE774100	BIND HEAD BONDING B-T. SCREW	3x8 MFZN2B3	
124	WE200400	DISH HEAD B-TIGHT SCREW	3x6 MFN133	TI
124	WE200500	DISH HEAD B-TIGHT SCREW	3x6 MFN13BL	BL
125	WE774300	BIND HEAD B-TIGHT SCREW	3x8 MFZN2W3	
127	VS997700	BIND HEAD S-TIGHT SCREW	3x10 MFN133	
128	VT669300	PW HEAD B-TIGHT SCREW	3x8-8 MFC2	
129	WE774600	SCREW IC	3x18 MFZN2W3	
130	VY731200	BONDING HEAD TAPPING SCREW	3x10 MFN133	
131	WE774700	BIND HEAD S-TIGHT SCREW	4x10 MFZN2W3	
132	VD069600	PW HEAD S-TIGHT SCREW	4x8-10 MFN133	BL
132	VH313200	PW HEAD S-TIGHT SCREW	4x8-10 MFN13BL	TI
133	VY731400	DAMPER	HOLE	
141	WF487600	PLATE SIDE		BL
141	WF487800	PLATE SIDE		TI
165	VQ368600	PUSH RIVET	P3555-B	
		ACCESSORIES		
* 200	WF676300	REMOTE CONTROL	RAX16	
200-1	AAX70730	BATTERY COVER		CG-8912
202	V6267000	INDOOR FM ANTENNA	1.4m 1pc	UCRL
203	VQ147100	INDOOR FM ANTENNA	1.4m 1pc	AGE
204	VQ307400	AM LOOP ANTENNA	81-653-645-110	
		BATTERY, MANGANESE DRY	UM-4E 2pcs	

* New Parts

RX-397