

# QSC™

# Technical Service Manual

## RMX™ Series

### 2RU models

- ▲ RMX 850
- ▲ RMX 1450
- ▲ RMX 1850HD
- ▲ RMX 2450

**QSC™**

QSC Audio Products, LLC  
Costa Mesa, CA 92626 USA  
[www.qscaudio.com](http://www.qscaudio.com)



TD-000098-00  
Rev. C



# RMX Series

## Technical Service Manual

**RMX 850**  
**RMX 1450**  
**RMX 1850HD**  
**RMX 2450**



### **QSC Audio Products, LLC**

#### **Technical Services Group**

Phone: 1-800 QSC AUDIO (1-800-772-2834) USA only  
+1 (714) 957-7150

Fax: +1 (714) 754-6173

Postal: 1665 MacArthur Blvd.  
Costa Mesa, California 92626 USA

E-mail: [tech\\_support@qscaudio.com](mailto:tech_support@qscaudio.com)

Web: <http://www.qscaudio.com> (product information and support)  
<http://www.qscstore.com> (parts and accessory sales)

Copyright 2001, 2002, 2005, 2008 QSC Audio Products, LLC All rights reserved.

Document # TD-000098-00, Rev. C. Released June 2008.

# RMX Series Performance Specifications

	RMX 850	RMX 1450	RMX 1850HD	RMX 2450
<b>OUTPUT POWER in watts</b>				
<i>FTC: 20 Hz–20 kHz @ 0.1% THD, both channels driven</i>				
8Ω per channel	185	260	350	450
4Ω per channel	280	400	550	650
<i>EIA: 1 kHz @ 0.1% THD, both channels driven</i>				
8Ω per channel	200	280	360	500
4Ω per channel	300	450	600	750
<i>1 kHz @ 1% THD, typical, both channels driven</i>				
2Ω per channel	430	700	900	1200
<i>Bridge Mono:</i>				
8Ω, 20 Hz–20 kHz, 0.1% THD	530	800		1300
8Ω, 1 kHz, 0.1% THD	600	900	1200	1500
4Ω, 1 kHz, 1% THD, typical	830	1400	1800	2400
<b>DYNAMIC HEADROOM</b>	2 dB @ 4Ω			
<b>DISTORTION</b>				
SMPTE-IM	< 0.01%	< 0.01%	< 0.02%	< 0.02%
<b>FREQUENCY RESPONSE</b>				
(at 10 dB below rated output power)	20 Hz–20 kHz, +0/-1 dB -3 dB points: 5 Hz and 50 kHz			
<b>DAMPING FACTOR</b>				
	> 300 @ 8Ω			
<b>NOISE</b> (unweighted 20 Hz to 20 kHz, below rated output)	100 dB	100 dB	100 dB	100 dB
<b>VOLTAGE GAIN</b>	31.6x (30 dB)	40x (32 dB)	46x (33 dB)	50x (34 dB)
<b>INPUT SENSITIVITY, V RMS</b>				
full rated power @ 8Ω	1.15v (+3.4 dBu)	1.15v (+3.4 dBu)	1.16v (+3.5 dBu)	1.23v (+4.0 dBu)
<b>INPUT IMPEDANCE</b>				
	10 kΩ unbalanced 20 kΩ balanced			
<b>CONTROLS</b>				
	Front: AC switch, Ch. 1 and Ch. 2 gain Rear: 10-position DIP switch			
<b>INDICATORS</b>				
POWER:	Green LED		CLIP:	Red LED, 1 per channel
SIGNAL:	Yellow LED, 1 per channel			
<b>CONNECTORS</b>				
Input:	Active balanced; XLR and ¼" (6.3 mm) TRS, tip and pin 2 positive, and barrier strip			
Output:	"Touch-Proof" binding posts and Neutrik Speakon™			
<b>COOLING</b>				
	Continuously variable speed fan, back-to-front air flow			
<b>AMPLIFIER PROTECTION</b>				
	Full short circuit, open circuit, thermal, ultrasonic, and RF protection Stable into reactive or mismatched loads			
<b>LOAD PROTECTION</b>				
	Turn-on/turn-off muting (all models)			
AC coupling	AC coupling		Triac crowbar (each channel)	Triac crowbar (each channel)
<b>OUTPUT CIRCUIT TYPE</b>				
AB	AB	H	H	
AB: Class AB+B complementary linear output H: Class AB+B complementary linear output with Class H 2-step high efficiency circuit				
<b>DIMENSIONS</b>				
	19.0" (48.3 cm) wide, 3.5" (8.9 cm) tall (2 rack spaces) 15.9" (40 cm) deep (rack mounting to rear support ears)			
<b>WEIGHT</b> Shipping:	41 lb. (18.6 kg)	46 lb. (20.9 kg)	50.5 lb. (23 kg)	50.5 lb. (23 kg)
Net:	35 lb. (15.9 kg)	40 lb. (18.2 kg)	44.5 lb. (20.2 kg)	44.5 lb. (20.2 kg)
<b>POWER REQUIREMENTS</b>				
Available for 120 or 220–240 VAC, 50/60 Hz				

## POWER CONSUMPTION @ 120 VAC (both channels driven)

Multiply currents by 0.5 for 230V units

	Typical <sup>1</sup>	Full <sup>2</sup>	Max <sup>3</sup>		Typical <sup>1</sup>	Full <sup>2</sup>	Max <sup>3</sup>		Typical <sup>1</sup>	Full <sup>2</sup>	Max <sup>3</sup>		Typical <sup>1</sup>	Full <sup>2</sup>	Max <sup>3</sup>
<i>Idle</i>	0.5 A			<i>Idle</i>	0.5 A			<i>Idle</i>	0.8 A			<i>Idle</i>	0.6 A		
<b>8Ω</b>	3 A	4.1 A	7.4 A	<b>8Ω</b>	3.7 A	5.4 A	10 A	<b>8Ω</b>	3.9 A	6.9 A	12.6 A	<b>8Ω</b>	4 A	9.7 A	16.4 A
<b>4Ω</b>	4.5 A	6.6 A	11.5 A	<b>4Ω</b>	6 A	9.6 A	16 A	<b>4Ω</b>	6.1 A	11.2 A	20.7 A	<b>4Ω</b>	6.3 A	15.6 A	27 A
<b>2Ω</b>	6.5 A	9.5 A*	17 A*	<b>2Ω</b>	9.3 A	14.7 A*	25 A*	<b>2Ω</b>	8.7 A	16.6 A*	32 A*	<b>2Ω</b>	9.2 A	23 A*	41 A*

**1. Typical**—Measured with pink noise signal on all channels at 1/8 of full average power. Producing peaks that occasionally reach the amp's clipping point, this level approximates the maximum operating level before clipping affects sound quality. These data would be the amp's typical worst-case current.

**2. Full**—Measured with pink noise signal on all channels at 1/3 of full average power. Music at this level would typically produce massive clipping. In a class B amplifier, this would be the approximate point of maximum heat production.

**3. Max**—Measured with continuous sine wave signal on all channels at a point of slight clipping (1% THD). This represents a "test bench" scenario and does not resemble any real-world usage.

US patents pending

**SPECIFICATIONS SUBJECT TO CHANGE WITHOUT NOTICE**

# Table of Contents

<b>RMX Series Performance Specifications .....</b>	<b>2</b>
<b>1. Introduction .....</b>	<b>5</b>
1.1 Restriction of Hazardous Substances Directive (RoHS) .....	5
1.2 QSC serial numbers .....	5
1.3 Service bulletins .....	5
1.4 The well-equipped service bench .....	6
1.5 Working with surface-mount components .....	6
1.6 Series description .....	8
1.7 Technical descriptions and theory of operation .....	8
<b>2. Component identification and pinout .....</b>	<b>11</b>
<b>3. Troubleshooting: Symptoms, causes, &amp; remedies .....</b>	<b>13</b>
3.1 Excessive current draw .....	13
3.2 Protection, muting, and turn-on/turn-off delay problems .....	13
3.3 Faults with signal present .....	14
3.4 Instability .....	14
3.5 Power supply and rail balancing problems .....	15
<b>4. RMX calibration procedures .....</b>	<b>16</b>
4.1 Setting bias .....	16
4.2 Setting positive and negative current limits .....	16
<b>5. Servicing RMX amplifiers .....</b>	<b>18</b>
5.1 Mechanical disassembly and re-assembly .....	18
<b>6. Replacement parts .....</b>	<b>19</b>
6.1 RMX850 Replacement Parts .....	19
6.2 RMX1450 Replacement Parts .....	22
6.3 RMX1850HD Replacement Parts .....	25
6.4 RMX2450 Replacement Parts .....	29
<b>7. Schematics and diagrams .....</b>	<b>33</b>
7.1 RMX Assembly/Disassembly Diagram 1 of 2 (All models) .....	33
7.2 RMX Assembly/Disassembly Diagram 2 of 2 (All models) .....	34
7.3 RMX 850 Schematic Diagram 1 of 3 Channel 1 .....	35
7.4 RMX 850 Schematic Diagram 2 of 3 Channel 2 .....	36
7.5 RMX 850 Schematic Diagram 3 of 3 Power Supply .....	37
7.6 RMX 1450 Schematic Diagram 1 of 3 Channel 1 .....	38
7.7 RMX 1450 Schematic Diagram 2 of 3 Channel 2 .....	39
7.8 RMX 1450 Schematic Diagram 3 of 3 Power Supply .....	40
7.9 RMX 1850HD Schematic Diagram 1 of 3 Channel 1 .....	41
7.10 RMX 1850HD Schematic Diagram 2 of 3 Channel 2 .....	42
7.11 RMX 1850HD Schematic Diagram 3 of 3 Power Supply .....	43
7.12 RMX 2450 Schematic Diagram 1 of 4 Channel 1 .....	44

## Table of Contents (continued)

7.13 RMX 2450 Schematic Diagram 2 of 4 Channel 2 .....	45
7.14 RMX 2450 Schematic Diagram 3 of 4 Power Supply .....	46
7.15 RMX 2450 Schematic Diagram 4 of 4 Power Supply Revision .....	47
7.16 RMX Power Transformer Configurations March 2007 and later .....	48
7.17 RMX 850 Chassis Wiring Diagram .....	49
7.18 RMX 1450 Chassis Wiring Diagram .....	50
7.19 RMX 1850HD and RMX 2450 Chassis Wiring Diagram .....	51

# 1. Introduction

## 1.1 Restriction of Hazardous Substances Directive (RoHS)

Since April 2006, all RMX Series amplifiers are manufactured to conform to the European Union's RoHS Directive, which reduces the amount of hazardous substances allowed in products for sale within its member nations. In electronic equipment such as audio power amplifiers, this applies primarily to certain toxic heavy metals, such as lead, which may be present in electronic components, solder, and other parts.

### RoHS-compliant materials

When servicing RoHS-compliant amplifiers, it is important for the service technician to use only RoHS-compliant components and solder (lead-free). All replacement parts provided by QSC for RoHS-compliant products are certified as RoHS compliant.

### RoHS-compliant tools

Soldering irons and desoldering apparatus used on RoHS-compliant products must also not be contaminated by hazardous substances, such as lead. Therefore, you cannot use the same soldering and desoldering tools for RoHS-compliant products and solder as you do for non-compliant products and solder. You must either use separate soldering irons, desoldering tools and braid, etc., or at the very least designate separate tips and braids and use only the appropriate ones. If you contaminate a tip or braid, even inadvertently, by using it on a non-compliant product or solder, you should no longer use it with RoHS-compliant products or solder.

## 1.2 QSC serial numbers

Serial numbers on QSC RMX series amplifiers are nine digits long. The first four digits are a manufacturing date code in *mmyy* format; the last five digits are the sequential identifying number for each individual amplifier. For example, a serial number of 0807xxxx would indicate that the amplifier was built in 08/2007, or August 2007. The date code is important for determining whether an amplifier is subject to a service bulletin, covered by a warranty (in the absence of original purchase records), etc.

The amplifier's serial number can be found on a label on the rear panel. The label also indicates the model number, power rating, 4 $\Omega$  current draw, and the AC mains voltage the amplifier was made for.

Certain design changes that the RMX amplifiers have undergone commenced with a particular date code; for example, the RMX amplifiers with a date code of 0406 or later conform to the European Union's RoHS Directive and must be serviced only with lead-free solder and soldering irons that are not contaminated with lead or other heavy metals covered by the directive.

## 1.3 Service bulletins

Contact QSC Technical Services to make sure you have the most up-to-date service bulletins for RMX Series amplifiers. Service bulletins may be distributed in hard copy, via fax, and electronically (Adobe Acrobat PDF) via CD-ROMs, FTP from the QSC web site ([www.qscaudio.com](http://www.qscaudio.com)), and e-mail.

These service bulletins had been issued at the time this manual was printed:

- **RMX0001**, "Q205 Lead Stress" (RMX2450 only)
- **RMX0002**, "RMX Turn-on Delay" (all RMX models)
- **RMX0003**, "RMX2450 Turn-off Mute" (RMX2450)
- **RMX0004**, "RMX2450 AC Wire Routing" (RMX 2450)
- **RMX0005**, "RMX2450 AC Wire Replacement" (RMX2450)
- **RMX0006**, "RMX2450 IRFZ44N Field Effect Transistors (RMX2450)



Figure 1.1. The label displays two vital pieces of information: the amplifier's serial number and operating voltage

## 1.4 The well-equipped service bench

To properly service RMX amplifiers, a technician needs the right tools. The technician's service bench should have the following equipment:

- Digital multimeter with RMS AC voltage and current
- Digital clamp-on ammeter
- Dual-trace oscilloscope
- Audio distortion analyzer
- Non-inductive load resistors, configurable as 8 ohms (min. 500 watts capacity), as 4 ohms (min. 750 watts capacity), and 2 ohms (min. 1200 watts capacity); see Figure 1.2 and Table 1.1.
- Variable AC voltage source, such as a Variac or Powerstat variable transformer, with a rated current capacity of up to 25A (for 120V models) or 12A (for 230V models)
- Low-distortion audio sine wave generator
- Philips and flat screwdrivers
- Soldering iron with a fine tip, 25–60W recommended (if you service both RoHS-compliant and non-compliant amplifiers, you will need separate soldering and desoldering equipment for each)
- Appropriate rosin-core solder (use only RoHS compliant lead-free solder for RoHS-compliant amplifiers; for non-RoHS amplifiers, use a 60/40 or 63/37 Pb/Sn alloy)
- Long-nose pliers
- Diagonal cutters
- Wire strippers

Automated test equipment, such as an Audio Precision workstation, is very useful for servicing RMX amplifiers. Contact QSC Technical Services to obtain applicable AP test files.

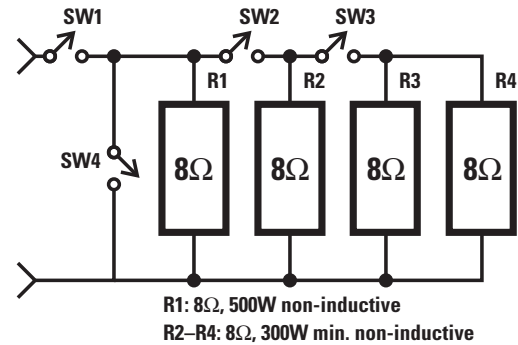

Figure 1.2. Load resistor bank

Table 1.1. Load resistor bank switch truth table

	SW1	SW2	SW3	SW4
$\infty\Omega$ (no load)	OFF	•	•	•
$8\Omega$	ON	OFF	OFF	OFF
$4\Omega$	ON	ON	OFF	OFF
$2\Omega$	ON	ON	ON	OFF
$0\Omega$ (short circuit)	ON	•	•	ON

## 1.5 Working with surface-mount components

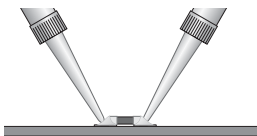

Figure 1.3.

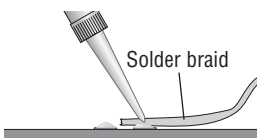

Figure 1.4.



Figure 1.5.

RMX amplifiers, like many modern electronic products, use surface-mount technology (SMT) components where appropriate in order to make high-density circuitry that is reliable and economical to manufacture.

SMT components in the RMX amps are used in the small-signal and control circuits, so they do not handle significant amounts of power; therefore, they are subject to very little stress and should seldom fail.

Sometimes they do fail, or they require replacement for a performance upgrade or modification. Thus, it is important to know how to work with SMT components.

Specialized tools and equipment exist for soldering, unsoldering, and removing SMT components quickly and efficiently, but they are often expensive. Most SMT repairs, though, can be handled reasonably well with common tools and equipment, such as tweezers, solder braid, and fine-tip soldering irons. The original factory components are tacked to the board with a spot of glue, so you might have to apply some force to break the adhesive.

### Two-terminal components (resistors, capacitors, diodes, etc.)

#### Removal

- 1 Use two soldering irons, preferably about 25 to 40 watts, with fine tips.
- 2 With a soldering iron in each hand, hold one tip on the solder at one end of the component and the other tip on the other end (Figure 1.3).
- 3 Once the solder melts on both ends, grip the component between the two tips and lift it from the circuit board.
- 4 Use solder braid and a soldering iron to remove the solder from the two pads (Figure 1.4).



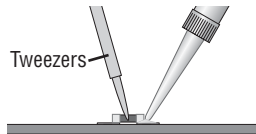

Figure 1.6.

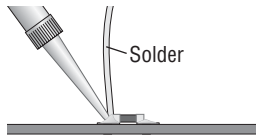

Figure 1.7.

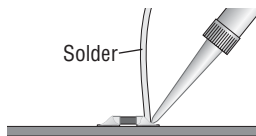

Figure 1.8.

### Insertion

- 1 With a soldering iron and appropriate solder, melt just enough solder onto one pad to create a small mound (Figure 1.5).
- 2 Grasp the component in the middle with tweezers. Melt the small mound of solder with the iron and place the component across the two pads (in the correct orientation, if the component is sensitive to direction) and press it flat against the circuit board, with one end of the component immersed in the melted solder (Figure 1.6).
- 3 Hold the component in place and take the soldering iron away. Let the solder harden to tack the component in place.
- 4 Fully solder the other end of the component to its pad. Let the solder harden (Figure 1.7).
- 5 Fully solder the tacked end of the component to its pad (Figure 1.8).

### Three-terminal components (transistors, etc.)

#### Removal

- 1 With a soldering iron and solder braid, remove as much solder as possible from the middle terminal of the component.
- 2 With a soldering iron in each hand, hold one tip on the solder at the terminal at one end of the component and the other tip on the terminal at the other end.
- 3 When the solder on both ends melts, grip the component between the two tips and lift it from the circuit board. You might need to quickly touch the pad on the middle terminal with a soldering iron to melt any remaining solder that might be holding the component down.
- 4 Use solder braid and a soldering iron to remove the solder from the three pads.

#### Insertion

- 1 With a soldering iron and appropriate solder, melt just enough solder onto one pad to create a small mound of solder.
- 2 Grasp the component with tweezers. Melt the small mound of solder with the iron and place the component in the correct orientation across the three pads and press it flat against the circuit board, with one terminal of the component pressed into the melted solder.
- 3 Hold the component in place and take the soldering iron away. Let the solder harden to tack the component in place.
- 4 Fully solder the other terminals of the component to their pads. Let the solder harden.
- 5 Fully solder the tacked terminal of the component to its pad.

### Multi-pin components (ICs, etc.)

#### Removal

Removing a multi-pin SMT component is a delicate procedure. Ideally, you should use a soldering iron with an attachment that allows you to heat all the pins simultaneously.

If such a soldering device is not available, use this procedure:

- 1 Use a soldering iron and solder braid to remove as much solder as possible from the pins of the component.
- 2 With fine tweezers, carefully try to lift each pin to see if it's free. If it's not, touch it with the tip of the soldering iron and if necessary, use the solder braid to remove the remaining solder.
- 3 Repeat the process until all the pins are free and you can remove the component.

#### Insertion

- 1 With a soldering iron and appropriate solder, melt just enough solder onto one pad to create a small mound of solder. It is usually easiest to use a pad that corresponds to one of the end or corner pins of the component.
- 2 Grasp the component with tweezers. Melt the small mound of solder with the iron and place the component in the correct orientation upon its pads and gently press it flat against the circuit board, with the appropriate terminal of the component pressed into the melted solder.
- 3 Hold the component in place and take the soldering iron away. Let the solder harden to tack the component in place.
- 4 Fully solder the other terminals of the component to their pads. Let the solder harden.
- 5 Fully solder the tacked terminal of the component to its pad.

## 1.6 Series description

QSC's RMX Series amplifiers are entry-level professional audio products, designed for good, basic performance and reliability at low price. The series comprises six two-channel models; this manual covers the four two-rack-space models: the RMX850, RMX1450, RMX1850HD and RMX2450. See page 2 for complete

specifications. The three-rack-space models—the RMX4050HD and the RMX5050—are covered by another service manual.

The RMX850 and RMX1450 have single-sided printed circuit boards. The RMX1850HD and RMX2450 use double-sided boards.

## 1.7 Technical descriptions and theory of operation

Note: Some of these descriptions concern circuitry that is duplicated in the amplifier's two channels. For the sake of simplicity, the descriptions are of Channel 1 only. Components in Channel 1 have a 3-digit designation with "1" as the first digit; their equivalents in Channel 2 have a "2" as the first digit, followed by the same two numerals. For example, R122 and R222 have identical functions in their respective channels.

### Power supplies

Unlike other recent QSC amplifiers, the RMX line uses strictly conventional power supplies, with large transformers that operate at the 50 or 60 Hz frequency of the AC line. The electrical current in the secondary circuitry is converted to DC through a full-wave bridge rectifier. The resulting 100 or 120 Hz ripple is filtered out by large capacitors that also serve as current reservoirs for short-term, transient demands.

The supply provides a bipolar set of supply rails for each channel, with equal quiescent positive and negative voltages, as shown in Figure 1.9. Note that unlike many bipolar supplies for complementary transistor arrangements, the secondary windings are not connected to ground at the center.

This is because the output transistors are directly mounted to the heat sink, metal-to-metal, to maximize heat transfer; this grounds the collectors, requiring somewhat different output and power supply arrangements. The grounded-collector concept is described later in this chapter.

In the RMX1850HD and RMX2450, the secondaries are tapped to provide an

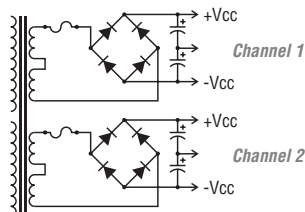

Figure 1.9

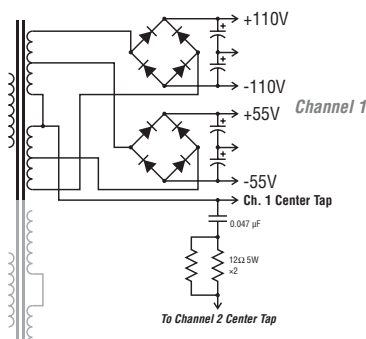

Figure 1.10

intermediate set of bipolar rails for the Class H output circuitry. Figure 1.10 shows one channel. Class H operation is described later in this chapter.

The 24-volt cooling fan is driven by a separate DC supply that is powered by a 20-volt tap on the transformer primary. To minimize fan noise, the fan speed is controlled by varying its actual DC voltage in response to the amplifier's heat sink temperatures. An optocoupler isolates the fan control circuitry from the thermal sensors.

### Audio circuitry

The audio inputs are balanced to offer a reasonably high amount of common-mode noise rejection. The input balancing is done using a single op amp (one half of an NE5532 dual op amp) arranged as a differential amplifier. The degree of common-mode rejection is dependent on a close match between the input resistors (R100 and R101 in Figure 1.11) and between the feedback resistor and the shunt resistor (R105 and R106). The circuitry uses 1% precision resistors to ensure at least 40 dB of common-mode rejection.

The feedback and shunt capacitors, C101 and C103, add a first-order high-frequency roll-off, down 3 dB at 88.4 kHz (over two octaves above the high end of the audio spectrum). This makes the amplifier less susceptible to RF interference, high-frequency oscillations, etc.

Also in this stage, the feedback loop contains one half of an NE5517 (equivalent to the more familiar LM13600) dual operational transconductance amplifier (Figure 1.12). The OTA is part of the clip limiter circuitry; when the clip limiter is activated, a control voltage increases the transconductance of the OTA, which essentially decreases the impedance of the feedback loop and reduces the gain of the stage in order to reduce the amount of clipping.

The gain control uses a linear potentiometer, but the impedances loading the wiper to ground make the pot approximate an audio taper over most of its rotation. After the wiper, RC networks roll off the low end, if the LF filter is set for that channel, at either 30 or 50 Hz, depending on the DIP switch setting on the rear panel.

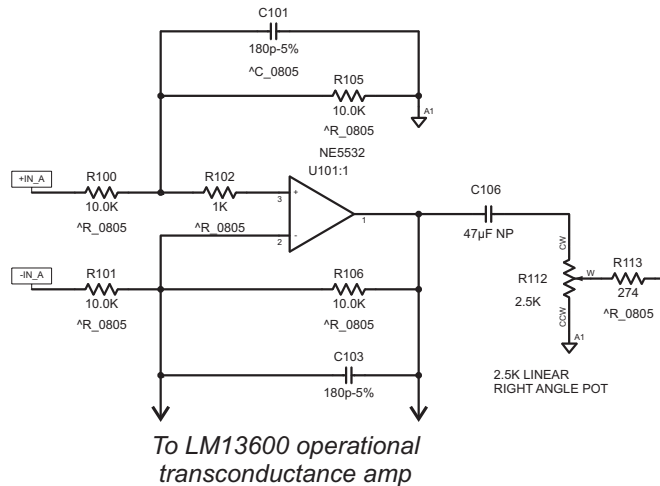

Figure 1.11

The next active device is another 5532 op amp, U101:2. Its output drives the driver transistors, which in turn drive the output transistors. The output section has a Class AB+B configuration; the drivers (a complementary pair, Q105 and Q106, comprising an NPN MJE15032 and a PNP MJE 15033) are class AB. A series network of two diodes and a 100-ohm trimpot provide the small amount of forward bias on the transistor pair to keep crossover distortion minimal. In parallel with the trimpot is a 50-ohm thermistor with a negative temperature coefficient; as the circuitry warms, its resistance decreases. This reduces  $V_{BE}$  on both Q105 and Q106, decreasing the bias current to reduce the threat of thermal runaway. The base of each driver transistor is tied to ground through a diode and a 2.2 kΩ trimpot in series; these set the current limiting threshold for their respective signal polarities.

The collector of each driver transistor directly drives the bases of its output transistors, which are the main power-handling signal devices. If you're not familiar with the grounded-collector scheme,

the arrangement of the output transistors might look somewhat backwards: PNP transistors connected to the positive voltage rail, and NPN on the negative rail. Not only that, but the transistors attached to the positive rail are for pulling the output voltage negative, and the ones on the negative rail swing the output positive. The collectors all connect to ground, which allows them to be mounted directly to the heat sink—metal-to-metal, without insulators in between—for the best possible transfer of heat away from the transistors. The emitters of the PNP and NPN transistors are coupled through resistors to the positive and negative supply rails, respectively, forming banks of common-emitter circuits driving the supply rails. Consequently, the devices drive the rails with the audio signal, which rides atop the DC. The output to the speaker load is taken from the point between the positive and negative reservoir capacitors; this is also where the negative feedback is taken from. The nature of this arrangement, with audio signal riding on the supply rails, is why the power supply has no ground reference.

Another unusual characteristic of the grounded-collector output section is that the signal at the output to the speaker is actually opposite in polarity to the signal at the op amp output. This is why the negative feedback resistor, R122, connects to the op amp's non-inverting input instead of the inverting input.

The output point of the circuit couples to the output connector through an RLC network (R160, R161, R162, L100, and C124) that serves as a high-frequency snubber and also helps keep the amp circuitry stable when driving capacitive loads.

### Clip detection

The output of the op amp also drives a group of four diodes (D102, D103, D105, and D106) arranged as a full-wave rectifier. Normally, the op amp's output signal level is about 1 volt or less, which is all it takes to drive the driver transistors.

But because this point is within the overall feedback loop, when clipping occurs, the op amp approaches full open-loop gain and puts out a much higher signal voltage to try to make the output signal track the input. The four diodes rectify the voltage to drive the clip indicator LED, LD100. The current exiting the full-wave rectifier passes to ground through R127 and also drives the base of transistor Q100 through R115. If the clip limiter is switched on, Q100's emitter is grounded, and when the voltage across R127 goes sufficiently negative to forward-bias Q100, which sends current through R111 and R103 into the amplifier bias input of the operational transconductance amplifier (OTA), U101:1. The OTA is in the negative feedback loop of U101:1, and increasing its transconductance essentially reduces the impedance of the feedback loop, which reduces the gain of the op amp stage. This reduces the signal level until the amount of clipping is minimal. When the clipping stops, Q100 is no longer forward-biased, and the gain returns to normal.

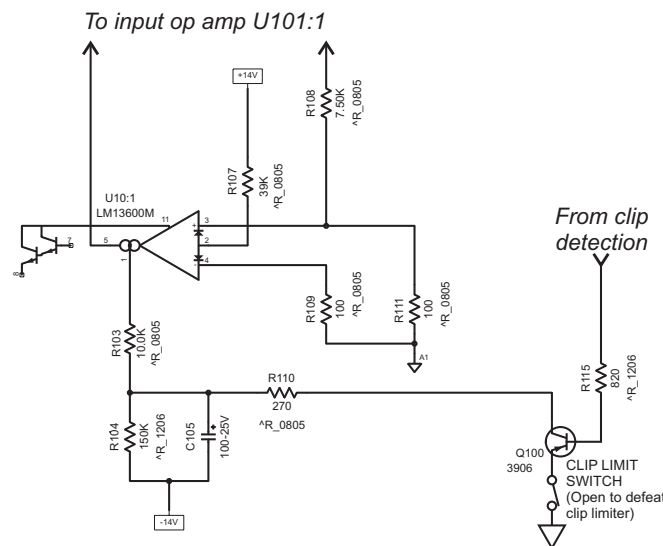

Figure 1.12

## DC protection

The RMX1850HD and RMX2450 have a crowbar circuit, based on a triac and two silicon controlled rectifiers, on the output to protect against DC faults. If an amp channel puts out a DC voltage, which could be the result of a component or circuit failure, it will first trigger either D119 or D120, depending on the polarity of the voltage. The triggered SCR will in turn trigger triac Q113, shorting the output to ground through fuse F100. The fuse will blow, safeguarding the speaker load from the DC fault.

The output sections of the RMX850 and RMX1450 are AC coupled.

## Class H

The RMX1850HD and RMX2450 utilize a two-step Class H output section. It is essentially a Class AB+B circuit but with two sets of bipolar supply rails. On both the positive and the negative sets of rails, a comparator circuit, called a "step driver," compares the audio signal to the lower rail voltage. When necessary to fully reproduce the signal's voltage swing—just before the instantaneous signal voltage reaches the lower rail voltage—the step driver turns on a TMOS power FET to pull the output transistors' supply rail up from the lower voltage to the higher one, and then back down again when the signal allows. By keeping the transistors' supply rails low whenever possible, the devices dissipate less unused power and generate less waste heat, making the amplifier more efficient than a straight class AB amplifier with the same power points (Figure 1.13).

The comparators are 311-type ICs: U170 on the positive step and U171 on the negative. Each one drives a high-gain complementary transistor pair (2N3904 + 2N3906), which drive the gate of their respective MOSFET.

## Bridged mono operation and protection

When the amplifier is operated in bridged mono, its two channels work in tandem to produce up to twice the voltage swing that a single channel is capable of. To do this, Channel 2 produces a signal identical to Channel 1's, but opposite in polarity—in other words, a mirror image.

Channel 2's signal feed (bus BR\_MONO\_FEED) is an attenuated version of the signal on Channel 1's speaker bus. Closing DIP switch #6 (set to "BRIDGE MONO ON"), connects the BR\_MONO\_FEED bus on Channel 1 to the BR\_RET bus on Channel 2. The BR\_RET bus drives the non-inverting input of op amp U201:2 directly.

With two channels operating as one, but each having its own feedback and protection circuitry, it is vital to keep both running as mirror images. A protection circuit monitors the balance between Channel 1's and Channel 2's signals. Resistors R22 and R23 (R22A, R22B, R23A, and R23B on the RMX2450) are equal in value and

form a voltage divider between the two channel outputs. If the output signals are mirror images, the voltage at the junction of the resistors (bus BR\_BAL) will be zero. If the signals are not mirror images—for example, one channel is defunct, distorting, or reduced in gain—a voltage will appear on BR\_BAL. Through DIP switch 7, the BR\_BAL bus becomes bus BR\_CUT and feeds the bases of transistors Q8 and Q6, which are part of a 4-transistor circuit across the +15V and -15V rails that supply the op amps and the input circuitry. If the voltage on BR\_CUT goes positive enough to forward-bias Q8, the transistor's collector will collapse the +15V rail. At the same time, the emitter current from Q8 will flow

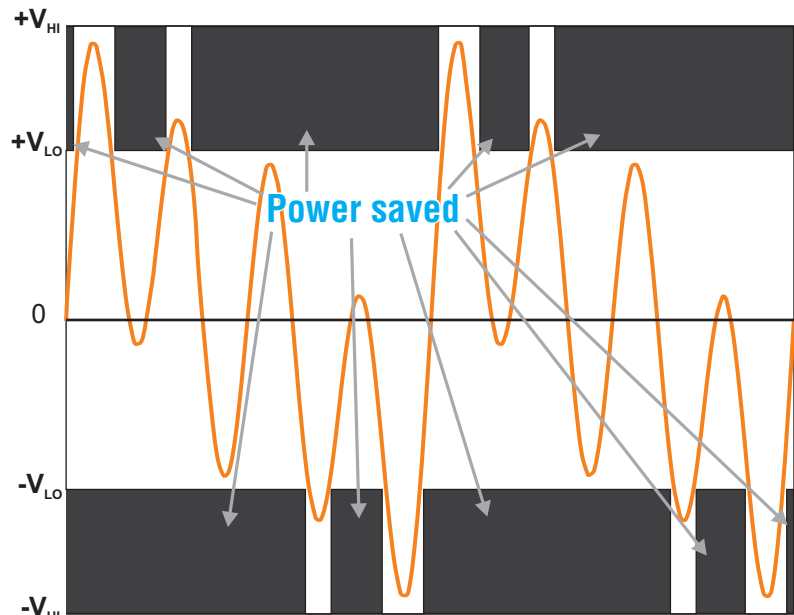

Figure 1.13. A two-tier class H amplifier circuit operates on the lower voltage rails until the signal amplitude requires the higher voltage.

through R25 and into the emitter of Q7, forward-biasing it, too. The collector of Q7 will then collapse the -15V rail.

Similarly, if BR\_BAL goes sufficiently negative, it will forward-bias Q6, in turn forward-biasing Q9, and these will collapse the  $\pm 15V$  rails.

With the rails collapsed, the op amp and the input circuitry will not function, which will mute the audio.

# 2. Component identification and pinout

## NE5532AN Dual operational amplifier

(part number IC-000211-GP; was 3130-2430-0)

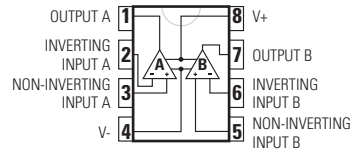

## NE5517D Dual operational transconductance amplifier (may be substituted by LM13600 or LM13700)

(part number IC-000212-GP; was 3131-9730-0)

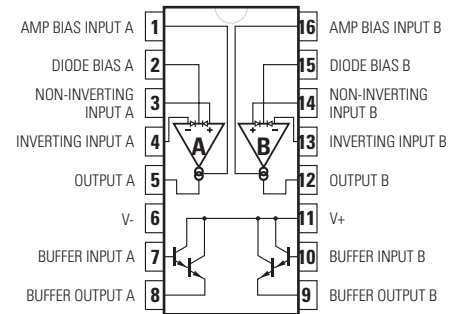

## LM311 Voltage comparator

(part number IC-000214-GP; was 3130-9240-0)

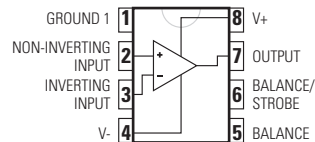

## 2N5064 Sensitive gate thyristor

(part number QD-000350-10; was 4860-5250-5)

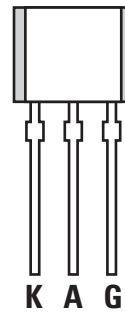

## 4N29 Opto-isolator

(part number IC-000213-GP; was 3130-9270-0)

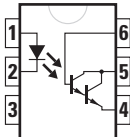

## IRFZ44 TMOS power field effect transistor

(part number QD-000347-GP; was 490F-Z440-5)

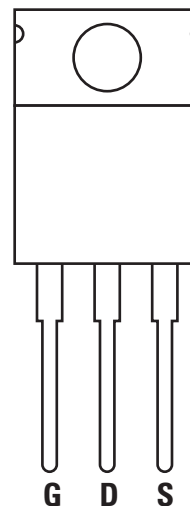

## 2N3904 (NPN) Small-signal transistor

(part number QD-000204-GP; was 4860-0640-3)

## 2N3906 (PNP) Small-signal transistor

(part number QD-000205-GP; was 4853-9060-3)

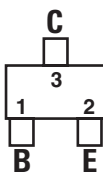

**MAC224 Triac (discontinued; see BTA41 triac below)**

(part number QD-000221-GP; was 8910-0482-0)

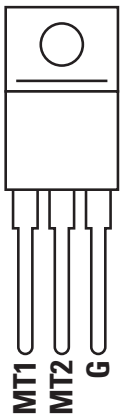

**MJE15032 (NPN) Driver transistor**

(part number QD-000207-GP; was 4860-5020-5)

**MJE15033 (PNP) Driver transistor**

(part number QD-000210-GP; was 4860-5030-5)

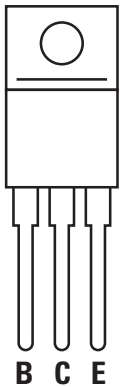

**2SC5200 (PNP) Power transistor**

(part number QD-000209-GP; was 4860-5050-5)

**2SA1943 (NPN) Power transistor**

(part number QD-000208-GP; was 4860-5060-5)

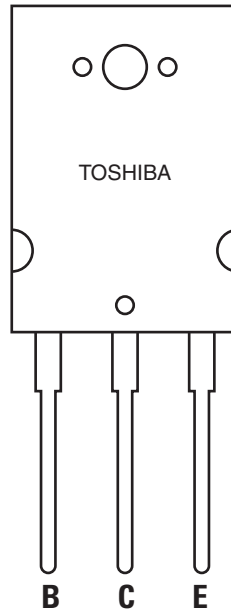

**BTA41 Triac**

(part number QD-000261-GP; replaces discontinued MAC224 Triac)

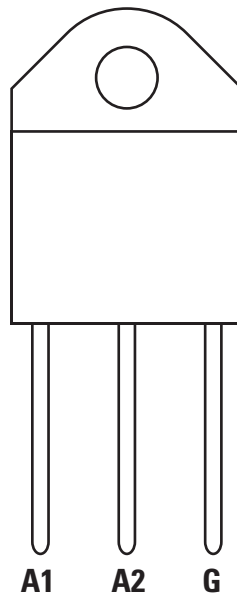

**10 kΩ Potentiometer (gain control)**

(part number PT-310006-GP; was 4750-6200-0; used April 2002 and earlier with 10 μF C106)

**2.5 kΩ Potentiometer (gain control)**

(part number PT-225000-GP; was 4751-0420-0; used May 2002 and later with 47 μF C106)

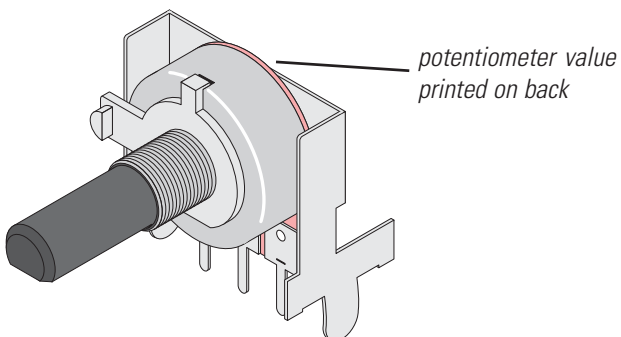

*Note: To install the BTA41 Triac on a channel module circuit board that originally held a MAC224 Triac, first mount it to an adapter (QSC part number SR-000117-00) and then solder the adapter to the circuit board. See Service Bulletin RMX0008 for more information. The Triac and adapter are available together as a kit, QSC part number SG-000522-00.*

# 3. Troubleshooting: Symptoms, causes, & remedies

When first checking the operation of an amplifier on the bench, always turn your variable transformer down to zero before plugging the amplifier in. After you turn the amplifier on, gradually turn up the AC voltage as you observe the amplifier's behavior and its current draw; this will help you determine what, if anything, is wrong with it. If you see or smell smoke, flames, or any other signs of short circuits or excessive current draw, quickly turn the AC back down to zero. If no such problems occur, it is usually safe to turn the AC up to the amplifier's full operating voltage for further testing.

## 3.1 Excessive current draw

The customer complains of blowing circuit breakers or fuses, or burning smell or smoke.

### Symptoms covered:

- Fuses blow immediately
- The amplifier quickly gets very hot
- Line circuit breakers trip at turn-on
- The amplifier hums loudly and the chassis vibrates
- The amplifier emits smoke
- The amplifier gives off a burning smell

If the symptoms indicate a possible problem in the channel circuits or output sections, you can isolate either channel module from the power supply by pulling its fuses from the AC board.

### Possible situations:

#### Excessive current with no signal present

If the amplifier seems to run hot and draws higher-than-normal current when idling at full AC voltage, the cause could be bias misadjustments in the output circuitry of one or both channels. See the calibration procedures in the next section. In the RMX2450, the cause might also be blown step FETs; see service bulletin RMX0006.

#### Fast increase in current draw (current increases rapidly at only a few volts AC)

- The main bridge rectifiers BR100 and/or BR200 (all models) and BR101 and/or BR201 (RMX2450) is reversed or shorted.
- Supply clamp diode pairs D117 and D118 and/or D217 and D218 is reversed or shorted.
- The drivers and/or power transistors is shorted on both polarities (NPN and PNP) on one or both channels.

#### Moderate increase in current draw (current increases slowly, doesn't become excessive until about ¼ of the amplifier's full AC operating voltage)

- One polarity's drivers and/or power transistors (NPN or PNP) is shorted, on one or both channels.
- Individual supply clamp diodes D117, D118, D217, or D218 is reversed or shorted.
- Bias diodes D108, D109, D208, or D209 or bias trimpots R131 or R231 is open.

#### Slow increase in current draw (current doesn't become excessive until about half of the amplifier's full AC operating voltage; amplifier may pass signal)

- The bias is severely misadjusted, or bias diodes D108, D109, D208, or D209 is defective.
- An oscillation is causing excessive current demand.

#### Runaway current draw (current increases sharply at about 25 to 33% of the amplifier's full AC operating voltage)

One or more reservoir capacitors is reversed. **CAUTION: the gas buildup in a reversed electrolytic capacitor can cause it to vent explosively.** Immediately turn off power and let the capacitor cool down before replacing it.

## 3.2 Protection, muting, and turn-on/turn-off delay problems

The customer complains of amplifier locking up, or not turning on and off correctly.

### Symptoms covered:

- Both channels do not come out of protect
- Amplifier will not thermally shut down when it should
- Power LED doesn't light
- Too little or too much muting delay
- No clip limiting
- Fan doesn't run, or runs always at high speed

### Possible situations:

#### Both channels stay in protect after turn-on

- Q4 or Q5 is shorted base-to-emitter.
- Voltage across D8 should be 14 to 15 volts DC. If it is low, check D8 and R10; also, C7 and C8 is leaky.
- D9, R4, and/or R7 is open.

### **The amplifier will not thermally shut down when it overheats**

Check for shorted D9, R4, or R7; check also for open LD1 (“POWER” LED), R2, or R5.

### **Too much or too little muting delay**

- Excessive delay at turn-on: check for open LD1, R2, or R5; check for incorrect R10 or R15; check for shorted D9; also see service bulletin RMX0002.
- Too short at turn-on (amplifier unmutes before the circuits stabilize, causing a thump): check for incorrect or bad C7, C8, or R10.
- Amplifier doesn’t stay muted at turn-off: see service bulletin RMX0003

### **Power LED doesn’t light**

Check for open or shorted LD1; check R2.

### **No clip limiting**

- U10 is defective.
- DIP switches SW1:1 or SW1:10 is defective.

### **Fan doesn’t run**

- The fan is defective.
- Check the fan connection to the AC board.
- Check R1 and BR1 on the AC board.

### **Fan runs always on high speed**

- Q3 and/or U2 are shorted.
- Check PTC thermistors R4 and R7.

## **3.3 Faults with signal present**

The customer complains that the amplifier passes a signal but doesn’t run correctly.

### **Symptoms covered:**

- The output signal breaks up or is distorted
- “Ringing” sound in loudspeaker when no audio signal is present
- The output signal collapses when driving a normal speaker load
- Supply rails OK with no signal, but collapse when a signal passes
- The amplifier gets too hot
- One channel clips prematurely
- Excessive hum in loudspeaker when no audio signal is present

### **Possible situations:**

#### **The output signal breaks up or is distorted**

- (RMX850 and RMX1450) Check the hum-null resistors R118, R119, R218, and R219.
- Check the ground traces for continuity among speaker ground, input ground, and AC ground.

#### **“Ringing” sound in loudspeaker when no audio signal is present**

- Check C114, C124, C214 and C224.
- Check or replace dual op amp U101 or U201.

### **The output signal collapses when driving a normal speaker load**

- R139, R140, R239, and/or R240 is misadjusted.
- Check R118, R119, R218, and R219.

### **The supply rails are OK with no signal but collapse with a signal**

- C112, C113, C212, and/or C213 is leaky.
- Check C114, C124, C214, and C224.

### **The amplifier gets too hot with no load**

- Bias trim pots R131 or R231 are misadjusted, burned, or open.
- Bias diodes D108, D109, D208 and/or D209 are incorrect (should be 1N4934).
- If the amplifier is producing high-frequency oscillations, check C114, C124, C214, and C224.
- Check resistors R136, R137, R236, and R237.
- Op amp U101 or U201 is unstable.

### **One channel clips prematurely**

- R146 or R147 (Channel 1) or R246 or R247 (Channel 2) are open.
- R139 or R140 (Channel 1) or R239 or R240 (Channel 2) are misadjusted.
- Check R157, R158, R198 (RMX1850HD and RMX2450 only), D115, and D116 (Channel 1) or R157, R258, R298 (RMX1850HD and RMX2450 only), D215, and D216 (Channel 2).
- (RMX850 and RMX1450) Check R118 and R119 (Channel 1) or R218 and R219 (Channel 2).
- R130 or R132 (Channel 1) or R230 or R232 (Channel 2) is open.

### **Excessive hum in loudspeaker when no signal is present (RMX850 and RMX1450)**

Check R118, R119, R218, and R219.

### **Excessive current draw with signal present (RMX1850HD and RMX2450)**

- Check triacs Q113 and Q213.
- Check D119, D120, D219 and D220.

## **3.4 Instability**

The customer complains of gain problems, spurious noises, or oscillations.

### **Symptoms covered:**

- General output distortion
- “Ringing” sound in loudspeaker trailing an audio signal
- Excessive crossover distortion
- The output waveform appears fuzzy on an oscilloscope

Distinguish among the different symptoms of fuzziness (instability), ringing (momentary instability after a transition), crossover distortion (often causing ringing), or general distortion.

### **Possible situations:**

#### **General distortion in the output signal**

- Severe distortion, at any load, often with abnormally high current draw: check the slew rate capacitors C114, C115, and



C116 (Channel 1) or C214, C215, and C216 (Channel 2).

- Moderate distortion, especially with light loading: stability capacitors C124 and C126 (Channel 1) or C224 and C226 is too high in capacitance; also check the slew rate capacitors C114, C115, and C116 (Channel 1) or C214, C215, and C216 (Channel 2), and the output filter resistors R161, R162, R154, and R155 (Channel 1) or R261, R262, R254, or R255 (Channel 2).
- Distortion with low gain: check the feedback shunt components R120, R138, and C125 (Channel 1) or R220, R238, or C225 (Channel 2); also check for broken circuit traces around the components; U101 (Channel 1) or U201 (Channel 2) is defective or its socket is contaminated.

#### **Ringling sound trailing the audio signal**

- This usually indicates marginal instability and is usually triggered by the signal passing through zero volts (the crossover point). Check the stability components and output filters.
- With a sine wave test signal, use an oscilloscope to check for excessive crossover notch at the output signal's zero crossings.

#### **Excessive crossover distortion (unbalanced, asymmetrical, or excessively large crossover notch)**

- Severe crossover discontinuity: bias diodes D108 or D109 (Channel 1) or D208 or D209 (Channel 2) are shorted.
- Moderate discontinuity: bias diodes D108 or D109 (Channel 1) or D208 or D209 (Channel 2) are out of spec.
- R131 (Channel 1) or R231 (Channel 2) is defective.
- Base resistors R136 or R137 (Channel 1) or R236 or R237 (Channel 2) are open. Also check the NTC thermistors R134 (Channel 1) or R234 (Channel 2).

## **3.5 Power supply and rail balancing problems**

### **Symptoms covered:**

- Insufficient or excessive current limiting into a shorted load
- Op amp rails too high with a shorted load
- Uneven voltages on supply rails

A channel's output current should remain unaffected when driving resistive loads as low as 2 ohms per channel. When driving a short circuit, the current limiting circuit should collapse the output to a lower current. This is done by dropping the op amp's supply rails from a normal  $\pm 14$ – $15$  volts down to about  $\pm 5$ – $6$  volts. Normally, the output signal helps replenish the op amp supply rails through D115 and D116 (Channel 1) and D215 and D216 (Channel 2), but a short circuit or excessively low load impedance prevents the replenishment, and the op amp rails collapse because they can't supply enough current to let the op amp drive both the clip LED and the driver transistors. The current limit trimpots R139, R140, R239, and R240 permit adjustment of the current limit thresholds. See the RMX calibration section of this manual for adjustment procedures.

### **Possible situations:**

#### **Excessive current into short (insufficient limiting)**

- If the op amp rails are dropping to  $\pm 5$  to 6 volts as they should: the 5.6V zener diodes D107 and/or D110 (Channel 1) or D207 and/or D210 (Channel 2) are reversed or shorted.
- If high crossover distortion is present: bias diodes D108 or D109 (Channel 1) or D208 or D209 (Channel 2) are shorted.

#### **Excessive current into short (op amp rails are not dropping)**

- The op amp U101 (Channel 1) or U201 (Channel 2) is defective, with insufficient output current.
- Clip LED LD100 (Channel 1) or LD200 (Channel 2) and/or its rectifying diodes (Channel 1: D102, D103, D105, D106; Channel 2: D202, D203, D205, D206) are open.
- When driving a short circuit, the output section's positive and negative supply rail voltages should be equal, within 3 volts. If they aren't, check D107, D110, R146, and R147 (Channel 1) or D207, D210, R246, and R247 (Channel 2).

#### **Weak current into 2 $\Omega$ or short (excessive or premature limiting)**

- Bias resistors R130 and R132 (Channel 1) or R230 and R232 (Channel 2) are too high.
- Driver transistors (Channel 1: Q105, Q106; Channel 2: Q205, Q206) have very low gain.
- One or more emitter resistors in the output section are open.

#### **Current OK at 2 $\Omega$ , weak into short**

- LD100, D102, D103, D105, or D106 (Channel 1), or LD200, D202, D203, D205, or D206 (Channel 2), are shorted.
- Zener voltage of diodes D107 or D110 (Channel 1), or D207 or D210 (Channel 2), is too high.

#### **Current limits properly into short, but current is weak at 2 $\Omega$**

- If the op amp rails are low ( $< 14$ – $15$  volts) when driving a 2-ohm load *without* clipping, check the resistors R157 and R158 (Channel 1, all models), R198 (Channel 1, RMX1850HD and RMX2450 only) and diodes D115 and D116 (Channel 1, all models), or R257 and R258 (Channel 2, all models), R298 (Channel 2, RMX1850HD and RMX2450 only) and diodes D215 and D216 (Channel 2, all models).
- If the op amp rails are normal ( $14$ – $15$  volts) when driving a 2-ohm load *without* clipping, usually the output section gain is too low: weak driver transistors, open output transistors, or open emitter resistors. Check the value of the driver transistors' emitter resistors, too: R146 and R147 (Channel 1) or R246 and R247 (Channel 2).

#### **Rail voltages unequal**

The balance between the positive and negative rail voltages is set by a voltage divider comprising resistors R118 and R119 (Channel 1) and R218 and R219 (Channel 2). If the amplifier channel passes a signal but clips unevenly due to unequal rail voltages, this voltage divider is the likely culprit.

# 4. RMX calibration procedures

## 4.1 Setting bias

Always set the bias

- after replacing any output or driver transistor.
- after replacing any diode or resistor in the driver/output circuitry.
- if the amplifier seems to run too hot at idle.
- if the amplifier exhibits crossover distortion.

The bias network sets the quiescent base current in the NPN and PNP driver transistors, which in turn sets the quiescent current in the output transistors. The driver transistors should both be slightly “on” at idle so that the transitions of the signal voltage between positive and negative are smooth and free of gaps or glitches. Too much bias current will cause the amplifier to run hotter than it should, especially at idle, while too little will cause noticeable crossover distortion, especially at low signal levels.

The amplifier circuitry must be cool, or at least within a couple degrees of ambient air temperature, and the top cover must be removed. If the driver and output transistors are significantly warmer than the ambient air, leave the amplifier off and let it cool before proceeding.

Before turning the amplifier on to set bias on one or both channels, familiarize yourself with the locations of the trimpots (R131 and R231) and the voltage measuring points so you can work quickly but thoroughly. If the amplifier warms up before you finish setting the bias, you will need to shut the amplifier off and let it cool down before you resume.

### Tools and resources you will need:

- Small flat screwdriver (non-conductive) for adjusting trimpots
- DC voltmeter
- AC power

### Procedure

1. Turn the amplifier’s gain controls all the way down. No test signal is needed.
2. Plug the amplifier into an appropriate AC source. Turn the amplifier on.
3. Channel 1: While measuring the DC voltage across resistor R146, adjust trimpot R131 to obtain the voltage listed in Table 1.
4. Channel 2: While measuring the DC voltage across resistor R246, adjust trimpot R231 to obtain the voltage listed in Table 1.

After setting the bias, calibrate the positive and negative current limiting; instructions for the procedure follow below.

## 4.2 Setting positive and negative current limits

### Tools and resources you will need

- Oscilloscope
- 2-ohm resistive load (rated for at least 1200 watts)
- Shorting connector for amplifier output
- Variable AC transformer (e.g., Variac, Powerstat, etc.) rated for 25A (120V) or 12A (230V). Make sure the AC supply is appropriate for the amplifier.
- 1 kHz audio sine wave generator
- Digital multimeter
- Clamp-on digital current meter (e.g., Fluke 30 Clamp Meter)
- Small flat screwdriver (non-conductive) for adjusting trimpots

### Procedure

1. Set the audio sine generator to 1 kHz at 1 volt RMS and connect it to Channel 1’s input. Connect a 2-ohm load and the oscilloscope probe across Channel 1’s output.
2. Turn up Channel 1’s gain control partway. On the oscilloscope you should see the amplitude of the sine wave increase accordingly.
3. Turn the gain control back down and apply a short circuit across the output terminals of Channel 1. Clamp a current probe either onto one of the brown wires running to the AC switch or onto the gray output wire from channel 1’s module.
4. Turn the gain control all the way up. Adjust trimpots R139 and R140 equally until the current measured falls within the range shown in Table 1.
5. Turn the gain control all the way down and remove the short circuit so the channel drives the 2-ohm load. Turn the gain control back up until the output clips. The voltage at which the signal starts to clip should fall within the range shown in Table 1. If the clipping is asymmetrical, that is, the signal clips on either the positive or negative side first, adjust R139 to make it symmetrical.
6. Turn the gain control down. If the amp has begun to warm up shut it off and let it cool a few minutes before proceeding with Channel 2.
7. Repeat steps 1 through 5 for Channel 2. Use trimpots R239 and R240 to adjust the current limiting in steps 11 and 12.
8. Turn both channels’ gain controls all the way down. Clamp the ammeter onto one of the amp’s AC wires and check the amp’s idle current. If the amplifier is still at about room temperature, the idle current should match the value shown in Table 1.

**Table 1: Bias and current limit adjustments**

Calibrations	Adjust	RMX850	RMX1450	RMX1850HD	RMX2450
Channel 1 bias: DC voltage across R146	R131	0.16 V	0.14 V	0.07 V	0.07 V
Channel 2 bias: DC voltage across R246	R231	0.16 V	0.14 V	0.07 V	0.07 V
Output current into shorted load	Channel 1: R139 & R140 Channel 2: R239 & R240	4–4.5 A	4–5 A	7.5–8.5 A	8.5–9 A
AC current when driving shorted load*	Channel 1: R139 & R140 Channel 2: R239 & R240	3.75–4.5 A	4.5–5.5 A	4.5–5.5 A	5.5–6.5 A
Clipping voltage into 2 ohms (RMS)	Channel 1: Adjust R139 for symmetry Channel 2: Adjust R239 for symmetry	26–29 V	33.5–37.5 V	42–44 V	44–49 V
Clipping voltage into 2 ohms (peak)	Channel 1: Adjust R139 for symmetry Channel 2: Adjust R239 for symmetry	36.8–41 V	47.4–53 V	59.3–62.2 V	62.2–69.3 V
Idle AC demand* (at ambient temperature; higher when hot)		0.4 A, ±10%	0.4 A, ±10%	0.6 A, ±10%	0.6 A, ±10%

\*Figures shown are for 120V amplifiers; multiply current by 0.5 for 230V or 1.2 for 100V.

# 5. Servicing RMX amplifiers

## 5.1 Mechanical disassembly and re-assembly

Replacing components will usually require removing the channel modules and/or AC board from the amplifier chassis, especially on the RMX850 and RMX1450, which have single-side printed circuit boards. The RMX2450 has double-side boards; many of the through-hole components on the upper side of the board can be unsoldered and soldered from the top side of the board, so removing modules or boards is not always necessary.

See the fold-out assembly guides on pages 25 and 26 in this manual for assistance.

*NOTE: As viewed from the front of the amplifier, the left channel module is Channel 1 and the right is Channel 2 except in the RMX2450; its right module is Channel 1, and its left is Channel 2.*

### Removing the channel modules

1. Disconnect the amplifier from AC power and allow at least 10 minutes for internal voltages to bleed down.
2. Using a Philips screwdriver, remove the screws that fasten the top cover to the chassis. Also remove the top cover's four recessed screws that fasten it to the heat sinks. As you remove screws, set them aside, but also make note of where each type is used so you can properly re-assemble the amplifier.
3. Lift the top cover up at the rear and carefully pull it toward the back, removing the five hooks on the front edge from their slots in the chassis.
4. Pull the gain control knobs straight off from the potentiometer shafts.
5. Tip the amplifier up on its side and remove the four screws that fasten the heat sinks to the chassis.
6. Set the amplifier back down and remove the screws that mount the channel modules to the chassis standoffs. There are six screws in the left module and five in the right one.
7. Remove the four screws that fasten the fan, fan shroud, and fan guard to the chassis. Lift the fan shroud out from the chassis; this will give you room to properly remove the modules from the chassis.
8. Disconnect the wire and cable connections to the channel modules. All of the connections are either detachable headers or ¼-inch quick-connect tabs that are disconnected by pulling them straight up. No unsoldering is necessary.

9. Slide the channel modules toward the back so the potentiometer shafts and front panel LEDs are clear of their holes in the front panel. Lift the channel modules out from the chassis.
10. Re-assembly is the opposite of disassembly.

### Removing the AC board

The AC board provides AC voltage selection, rectification of the transformer secondary current, and a regulated DC supply for the cooling fan. It seldom needs to be replaced unless it is physically damaged itself. Most failures involving the AC board can be repaired through replacement of individual components.

**WARNING:** Regulatory agencies require that any operating voltage conversions from 120 volts to any other voltage be done *only* by QSC's factory service. Any other operating voltage conversions may be done only by a QSC-authorized service center or international distributor.

1. Disconnect the amplifier from AC power and allow at least 10 minutes for internal voltages to bleed down.
2. Remove the four screws that fasten the fan, fan shroud, and fan guard to the chassis. Lift the fan shroud out from the chassis.
3. Disconnect the wires that connect to the channel modules. All of the large single wires attach to the channel modules with ¼-inch quick-connect tabs that are detached by pulling them straight up. The remaining three black wires disconnect at the left channel module with a detachable header.  
  
If you are planning to replace the AC board with another, carefully cut each of the transformer wires connecting to the board just above its solder tab. You must leave enough slack to allow connection to the new AC board. Remove the old heat shrink tubing from the wires and strip the wire ends about 0.25 inch or 6.3 mm.
4. Remove the five screws that attach the AC board to the chassis standoffs. Lift the board out from the chassis.
5. Re-assembly is the opposite of disassembly. If you're using a new AC board, slide new pieces of heat shrink tubing over the transformer wires before you solder them to the appropriate tabs on the board; after soldering, cover the joints with the tubing and use a heat gun or other heat source to shrink them tightly.

# 6. Replacement parts

## 6.1 RMX850 Replacement Parts

QSC part #	Old QSC part #	Description	Qty.	Notes or Component Reference
<b>Misc.</b>				
CH-000198-GP	4134-8432-0	RACK-MOUNT BRACKET	2	
CO-000211-GP	2113-1144-0	AC INLET, 250V 15A	1	
MS-000138-GP	8900-9050-1	DC FAN 24V 80X80 (+5V)	1	
PL-000147-GP	2444-1001-1	KNOB RMX PLASTIC BLACK	2	
SW-000086-GP	5200-3532-0	CIRCUIT BREAKER 10A	1	For 120V models
SW-000088-GP	5200-4717-0	ROCKER POWER SWITCH	1	
SW-000093-GP	5200-4730-0	CIRCUIT BREAKER 5A	1	For 230V models
WC-000181-GP	7010-9640-0	AC CORD 15A, 14 AWG, ISA	1	For 120V models
WC-000213-GP	7009-8620-0	AC CORD SET CE	1	For 230V models
*XF-000117-GP	1806-2505-0	POWER TRANSFORMER RMX850 120V/230V	1	Discontinued; replaced by XF-000314-GP and XF-000315-GP
XF-000314-GP	1806-3983+0000	TRANSFORMER, 230V, RMX850	1	For 230V models
XF-000315-GP	1806-3982+0000	TRANSFORMER, 120V, RMX850	1	For 120V models

### WP-008502-00 AC Board Assembly (was PCB-QZ010C-PSU)

CA-422005-GP	153R-224K-5-Y1	CM 250V 0.22uF 10% RL	2	C127, C227
CA-810006-GP	157Q-108M-5-X9E	1000UF 35V 20% ELECTROLYTIC	1	C6
HW-000020-GP	4134-8851-0	FUSE HOLDER 6.3MM	4	REF: F100, F200
IC-000213-GP	3130-9270-0	IC 4N29	1	U2
MS-000126-GP	5400-0831-0	HEATSINK, BRIDGE RECTIFIER	1	REF: Q3
MS-000129-GP	5100-1030-3A	FUSE T10A 125V/250V	2	F100, F200
QD-000200-GP	4840-1760-0	DIODE RECT 1A 200V DB103	1	BR1
QD-000214-GP	4860-2620-5	TR TIP31C SAMSUNG	1	Q3
QD-000227-GP	4840-2150-0	BRIDGE RECTIFIER 400V 25A	2	BR100, BR200
RE-000005-GP	8910-0273-0	POLY SWITCH 1.1A 0.15 OHM 1.5W	1	R1
RE-000270-GP	8910-0275-0	THERMAL NTC 30A 1 OHM	1	R21
RE-012004-GP	4719-121J-1-X	RMF 2W 120 OHM 5%	1	R17
RE-120003-GP	4701-202J-C	RCF 1/8W 2K 5% ATS	1	R13
RE-168002-GP	4701-682J-C	RCF 1/8W 6.8K 5% ATS	2	R9, R14
	4701-474J-C	RCF 1/8W 470K 5% ATS	1	R12

### WP-008503-00 Channel 1 Module Assembly (left) (was PCB-QZ010C-PWR1)

CA-233004-GP	153F-332J-5-KW	CM 50V .0033UF 5% RL	2	C117, C118
CA-322006-GP	153F-223J-5-LQ	CM 50V 0.022UF 5% RL	2	C116, C119
CA-368004-GP	153R-683J-5-WMM	0.068UF 5% 250V FILM DIPPED	1	C124
CA-547008-GP	157R-475M-5-0V	4.7UF 20% 250V ELECTRO RAD	1	C7
CA-647005-GP	157F-476M-5-LU	CE 50V 47UF 20% RL	1	C8
CA-847001-GP	8910-0062-0	CE 80V 4700U 20% RL 25X	2	C120, C121
PT-110002-GP	4756-1016-3-06	TRIM POT, 100, 20 PCNT, 0.15W, ,	1	R131
QD-000198-GP	3700-4531-G	LED 4.7MM GRN W/STAND	1	LD1
QD-000202-GP	4804-0040-1	DIODE IN4004 AL	5	D1, D11, D12, D117, D118
QD-000203-GP	4838-15V6-2	DIOD ZNR 15V 1W SILICON EPIT	2	D8, D15
QD-000206-GP	4804-9340-2	DIOD RECT FAST, IN4934 AT	2	D108, D109
QD-000207-GP	4860-5020-5	XISTOR NPN 250V 0.5A MJE15032	1	Q105
QD-000208-GP	4860-5060-5	TR 2SA1943 TO-3P (L)	3	Q103, Q107, Q109
QD-000209-GP	4860-5050-5	TR 2SC5200 TO-3P (L)	3	Q108, Q110, Q112
QD-000210-GP	4860-5030-5	XISTOR PNP 250V MJE15033	1	Q106
QD-000211-GP	4860-8890-0	TR MPSA06 VCE 80V NS	1	Q5
*QD-000212-GP	4837-5B10-2	DIODE ZENER 1/2W 5.5-5.8V	2	D107, D110 (December 2003 and earlier)
*QD-000269-GP	*	DIODE ZENER 5.1V 5% .25W DO-35	2	D107, D110 (January 2004 and later)
RE-.02201-GP	471A-022K-5-N	0.22 OHM 5% 3W THK FLM	6	R142, R148, R149, R152, R153, R159
RE-.56006-GP	4719-5R6J-1-X	RMF 2W 5.6 OHM 5%	1	R160
RE-.68001-GP	4718-6R8J-1-X	RMF 1W 6.8 OHM 5%	2	R146, R147
RE-000250-GP	8910-0488-0	NTC RES 50 OHM	1	R134

## RMX850 Channel 1 Module Assembly (continued)

QSC part #	Old QSC part #	Description	Qty.	Notes or Component Reference
RE-000260-GP	8910-0274-0	THERMAL PTC 60C 100 OHM	1	R7
RE-001201-GP	471B-120J-1-X	12 5% 5W METAL OXIDE FILM	2	R161, R162
RE-002202-GP	4718-220J-2-P	RMF 1W 22R 5% AT FP	2	R136, R137
RE-082005-GP	471B-821J-1-X	RMF 5W 820 OHM 5% AL METAL	2	R157, R158
RE-120007-GP	471B-202J-1-X	RMF 5W 2K 5% AL METAL	2	R133, R135
RE-122006-GP	4756-2226-3-06	SVR 2.2K H3 7X7	2	R139, R140
RE-215006-GP	4719-153J-1-X	RMF 2W 15K 5% AL METAL	2	R2, R5
XF-000190-GP	1804-1030-0	SPRING COIL 2uH	1	L100

### Channel 1 SMT parts

CA-210011-GP	150H-102J-6-CF	CC 100V 0.001U 5% 1206	1	C114
CA-222007-GP	150F-222K-6-CF	50V .0022UF 10% 1206 1	1	C115
QD-000201-GP	4804-1480-3	DIODE LL4148 SM	15	D2-D7, D9, D14, D104, D111-D116
QD-000204-GP	4860-0640-3	XISTOR NPN 60V 200MA 3904 SOT-23	4	Q8, Q9, Q101, Q102
QD-000205-GP	4853-9060-3	XISTOR PNP 40V 0.2A TR3906 SOT-23	3	Q4, Q6, Q7
QD-000213-GP	4860-5110-3	TR KST42	1	Q1
RE-004702-GP	4720-470J-J	RMG 1/10W 47 OHM 5% 0805	2	R25, R124
RE-082003-GP	4721-821J-6	RMG 1/8W 820 OHM 5% 1206	2	R130, R132
RE-115004-GP	4720-152J-J	RMG 1/10W 1.5K 5% 0805	1	R129
RE-120004-GP	4720-202J-J	RMG 1/10W 2K 5% 0805	1	R8
RE-168002-GP	4721-682J-6	RCF 1/8W 6.8K 5% ATS	1	R19
RE-210006-GP	4720-103J-J	RMG 1/10W 10K 5% 0805	1	R128
RE-247004-GP	4721-473J-6	RMG 1/8W 47K 5% 1206	1	R125
RE-315003-GP	4721-154J-6	RMG 1/8W 150K 5% 1206	1	R10
RE-322001-GP	4721-224J-6	RMG 1/8W 220K 5% 1206	2	R18, R27
RE-322002-GP	4720-224J-J	RMG 1/10W 220K 5% 0805	1	R26
RE-347002-GP	4721-474J-6	RMF 1/8W 470K 5% ATS	1	R15
RE-410002-GP	4721-105J-6	RMG 1/8W 1M 5% 1206	2	R3, R6

## WP-008504-00 Channel 2 Module Assembly (right) (was PCB-QZ010C-PWR2)

CA-233004-GP	153F-332J-5-KW	CM 50V .0033UF 5% RL	2	C217, C218
CA-322006-GP	153F-223J-5-LQ	CM 50V .022UF 5% RL	2	C216, C219
CA-368004-GP	153R-683J-5-WMM	0.068UF 5% 250V FILM DIPPED	1	C224
CA-415004-GP	153F-154J-5-NLM	0.15UF, 5%, 50V, CM, ,RBT, 7.5X	4	C108, C109, C208, C209
CA-422006-GP	153F-224J-5-NLM	CM 50V 0.22UF 5% RL	2	C107, C207
CA-610020-GP	157F-106M-5-LUN	CE 50V 10UF 20% RLT 5 X 11	2	C106, C206
CA-710009-GP	157E-107M-5-KW	CE 25V 100UF 20% RL	2	C105, C205
CA-722006-GP	157E-227M-5-PU	CE 25V 220UF 20% RL	4	C112, C113, C212, C213
CA-847001-GP	8910-0062-0	CE 80V 4700UF 20% RL 25X	2	C220, C221
CO-000222-GP	2101-1991-0	8-PIN IC SOCKET	2	REF: U101, U201
IC-000211-GP	3130-2430-0	IC NE5532 OP AMP	2	U101, U201
PT-110002-GP	4756-1016-3-06	TRIM POT, 100, 20 PCNT, 0.15W, ,	1	R231
*PT-225000-GP	*4751-0110-0	RES VAR 2.5K RT ANGLE PCB	2	R112, R212 (May 2002 and later)
*PT-310006-GP	*4750-6200-0	VR V012CPH, D-SHAFT 10K	2	R112, R212 (April 2002 and earlier)
QD-000197-GP	3700-4529-R	LED 4.7MM RED W/STAND	2	LD100, LD200
QD-000199-GP	3700-4530-Y	LED 4.7MM W/STAND YELLOW	2	LD101, LD201
QD-000202-GP	4804-0040-1	DIODE IN4004 AL	4	D10, D13, D217, D218
QD-000203-GP	4838-15V6-2	DIOD ZNR 15V 1W SILICON EPIT	4	D100, D101, D200, D201
QD-000206-GP	4804-9340-2	DIOD RECT FAST, IN4934 AT	2	D208, D209
QD-000207-GP	4860-5020-5	XISTOR NPN 250V 0.5A MJE15032	1	Q205
QD-000208-GP	4860-5060-5	TR 2SA1943 TO-3P (L)	3	Q203, Q207, Q209
QD-000209-GP	4860-5050-5	TR 2SC5200 TO-3P (L)	3	Q208, Q210, Q212
QD-000210-GP	4860-5030-5	XISTOR PNP 250V MJE15033	1	Q206
*QD-000212-GP	4837-5B10-2	DIODE ZENER 1/2W 5.5-5.8V	2	D207, D210 (December 2003 and earlier)
*QD-000269-GP	*	DIODE ZENER 5.1V 5% .25W DO-35	2	D207, D210 (January 2004 and later)
RE-.02201-GP	471A-022K-5-N	0.22 OHM 5% 3W THK FLM	6	R242, R248, R249, R252, R253, R259
RE-.56006-GP	4719-5R6J-1-X	RMF 2W 5.6 OHM 5%	1	R260
RE-.68001-GP	4718-6R8J-1-X	RMF 1W 6.8 OHM 5%	3	R20, R246, R247
RE-000250-GP	8910-0488-0	NTC RES 50 OHM	1	R234
RE-000260-GP	8910-0274-0	THERMAL PTC 60C 100 OHM	1	R4
RE-001201-GP	471B-120J-1-X	12 5% 5W METAL OXIDE FILM	2	R261, R262

## RMX850 Channel 2 module (continued)

QSC part #	Old QSC part #	Description	Qty.	Notes or Component Reference
RE-002202-GP	4718-220J-2-P	RMF 1W 22 5% AT FP	2	R236, R237
RE-082005-GP	471B-821J-1-X	RMF 5W 820 OHM 5% AL METAL	2	R257, R258
RE-120007-GP	471B-202J-1-X	RMF 5W 2K 5% AL METAL	2	R233, R235
RE-122006-GP	4756-2226-3-06	SVR 2.2K H3 7X7	2	R239, R240
RE-190903-GP	4717-9091-2	RMF 1/2W 9.09K 1% AT	1	R123
RE-210010-GP	4717-103A-2	RMF 1/2W 10.0K 1% AT	2	R122, R222
XF-000190-GP	1804-1030-0	SPRING COIL 2uH	1	L200

### Channel 2 SMT parts

CA-056001-GP	150F-560K-J-BD	CC 50V 56PF 10% 0805	2	C110, C210
CA-056002-GP	15CG-560J-6-CF	CTC 0/30 56P 5% 1206	2	C111, C211
CA-118000-GP	150F-181K-J-BD	CC 50V 180PF 5% 0805	4	C101, C103, C201, C203
CA-210011-GP	150H-102J-6-CF	CC 100V 0.001μF 5% 1206	1	C214
CA-222007-GP	150F-222K-6-CF	50V .0022UF 10% 1206	1	C215
CA-410013-GP	150F-104K-6-CF	CER 2 1206 10% 50V .1UF	3	C100, C102, C104
IC-000212-GP	3131-9730-0	IC NE5517D	1	U10
QD-000201-GP	4804-1480-3	DIODE LL4148 SM	15	D102, D103, D105, D106, D202-D206, D211-D216
QD-000204-GP	4860-0640-3	XISTOR NPN 60V 200MA 3904 SOT-23	2	Q201, Q202
QD-000205-GP	4853-9060-3	XISTOR PNP 40V 0.2A TR3906 SOT-23	2	Q100, Q200
RE-004702-GP	4720-470J-J	RMG 1/10W 47 OHM 5% 0805	1	R224
RE-010006-GP	4720-101J-J	RMG 1/10W 100 5%	6	R109, R110, R127, R209, R211, R227
RE-027003-GP	4720-271J-J	RMG 1/10W 270 OHM 5%	6	R111, R113, R120, R210, R213, R220
RE-082003-GP	4721-821J-6	RMG 1/8W 820 OHM 5% 1206	4	R115, R215, R230, R232
RE-110012-GP	4720-102J-J	RMG 1/10W 1K 5% 0805	3	R102, R126, R202
RE-115004-GP	4720-152J-J	RMG 1/10W 1.5K 5% 0805	1	R229
RE-133007-GP	4720-332J-J	RMG 1/10W 3.3K 5% 0805	1	R24
RE-147001-GP	4720-472J-J	RMG 1/10W 4.7K 5% 0805	2	R114, R214
RE-175003-GP	4720-752J-J	RMG 1/10W 7.5K 5% 0805	2	R108, R208
RE-210006-GP	4720-103J-J	RMG 1/10W 10K 5% 0805	3	R103, R203, R228
RE-210007-GP	4720-103A-J	10K 1% 1/10W THK FLM 0805	8	R100, R101, R105, R106, R200, R201, R205, R206
RE-220005-GP	4720-203A-J	RMG 1/10W 20K 1% 0805	4	R117, R121, R217, R221
RE-233001-GP	4721-333J-6	RMG 1/8W 33K 1% 1206	2	R22, R23
RE-239001-GP	4720-393J-J	RMG 1/10W 39K 5% 0805	2	R107, R207
RE-247004-GP	4721-473J-6	RMG 1/8W 47K 5% 1206	1	R225
RE-315003-GP	4721-154J-6	RMG 1/8W 150K 5% 1206	2	R104, R204
RE-315004-GP	4721-154A-6	RMG 1/8W 150K 1% 1206	4	R118, R119, R218, R219
RE-339001-GP	4721-394J-6	RMG 1/8W 390K 5% 1206	2	R116, R216

### Input Board Assembly (was PCB-QZ010C-INP)

CA-147006-GP	150F-471J-5-0F	470PF 5% 50V CER NPO	4	C1-C4
CO-000204-GP	2113-1337-1	CONN XLR F VERT PLASTIC	2	J101, J201
CO-000234-GP	2113-1335-0	5 POLE INPUT TERMINAL BLOCK	1	J5
CO-000235-GP	2113-1652-0	PHONE JACK 06.4	2	J102, J202
SW-000089-GP	5200-4713-0	10 POLE DIP SWITCH	1	SW1
WC-000194-GP	7010-9860-0	RIBBON CABLE 26 PIN IEC	1	J1

### Output Board Assembly (was PCB-QZ010C-OUT)

CO-000236-GP	2113-1336-1	SPEAKON NEUTRIK 4 WIRE	2	J100, J200
PA-000043-00	2113-1338-0	PLATE ASSY, PLX/RMX, OUTPUT,,	1	J103
PL-000055-00	4154-2111-0	OUTPUT POST PLUG FOR CE (RED)	2	For European models only
PL-000056-00	4154-2121-0	OUTPUT POST PLUG FOR CE (BLACK)	2	For European models only

## 6.2 RMX1450 Replacement Parts

QSC part #	Old QSC part #	Description	Qty.	Notes or Component Reference
<b>Misc.</b>				
CH-000194-GP	4134-9101-0	FAN SHROUD RMX	1	
CO-000211-GP	2113-1144-0	AC INLET 250V 15A	1	
MS-000137-GP	4154-0361-0	FAN GUARD WIRE 76MM RMX	1	
MS-000138-GP	8900-9050-1	DC FAN 24V 80X80 (+5V)	1	
SW-000088-GP	5200-4717-0	ROCKER POWER SWITCH	1	
SW-000091-GP	5200-3531-0	CIRCUIT BREAKER 15A	1	For 120V models
SW-000094-GP	5200-4731-0	CIRCUIT BREAKER 8A	1	For 230V models
WC-000181-GP	7010-9640-0	AC CORD 15A, 14 AWG, ISA	1	For 120V models
WC-000213-GP	7009-8620-0	AC CORD SET CE	1	For 230V models
*XF-000116-GP	1806-2506-0	POWER TRANSFORMER, RMX 1450	1	Discontinued; replaced by XF-000316-GP and XF-000317-GP
XF-000316-GP	1806-3985+0000	TRANSFORMER, 240V, RMX1450	1	For 230V models
XF-000317-GP	1806-3984+0000	TRANSFORMER, 120V, RMX1450	1	For 120V models

### WP-008502-00 AC Board Assembly (was PCB-QZ020C-PSU)

CA-422005-GP	153R-224K-5-Y1	CM 250V .22UF 10% RL	2	C127, C227
CA-810006-GP	157Q-108M-5-X9E	1000UF 35V 20% ELECTROLYTIC	1	C6
HW-000020-GP	4134-8851-0	FUSE HOLDER 6.3MM	4	REF: F100, F200
IC-000213-GP	3130-9270-0	IC 4N29	1	U2
MS-000124-GP	5120-0061-0	FUSE 12A 250V 6.3 X 32MM	2	F100, F200
MS-000126-GP	5400-0831-0	HEATSINK, BRIDGE RECTIFIER	1	REF: Q3
QD-000200-GP	4840-1760-0	DIODE RECT 1A 200V DB103	1	BR1
QD-000214-GP	4860-2620-5	TR TIP31C SAMSUNG	1	Q3
QD-000227-GP	4840-2150-0	BRIDGE RECT 400V 25A	2	BR100, BR200
RE-000005-GP	8910-0273-0	POLYSWITCH 1.1A 0.15 OHM 1.5W	1	R1
RE-000270-GP	8910-0275-0	NTC 30A 1 OHM	1	R21
RE-012004-GP	4719-121J-1-X	RMF 2W 120 OHM 5%	1	R17
RE-120003-GP	4701-202J-C	RCF 1/8W 2K 5% ATS	1	R13
RE-168002-GP	4701-682J-C	RCF 1/8W 6.8K 5% ATS	2	R9, R14
	4701-474J-C	RCF 1/8W 470K 5% ATS	1	R12

### WP-014502-00 Channel 1 Module Assembly (left) (was PCB-QZ020C-PWR1)

CA-233004-GP	153F-332J-5-KW	CM 50V .0033UF 5% RL	2	C117, C118
CA-322006-GP	153F-223J-5-LQ	CM 50V .022UF 5% RL	2	C116, C119
CA-368004-GP	153R-683J-5-WMM	0.068UF 5% 250V FILM DIPPED	1	C124
CA-547008-GP	157R-475M-5-0V	4.7UF 20% 250V ELECTRO RAD	1	C7
CA-647005-GP	157F-476M-5-LU	CE 50V 47uF 20% RL	1	C8
CA-833002-GP	8910-0272-0	3300UF 20% 100V ELECT RAD	4	C120-C123
PT-110002-GP	4756-1016-3-06	TRIM POT,100,20 PCNT,0.15W,,	1	R131
QD-000198-GP	3700-4531-G	LED 4.7MM GRN W/STAND	1	LD1
QD-000202-GP	4804-0040-1	DIODE IN4004 AL	5	D1, D11, D12, D117, D118
QD-000203-GP	4838-15V6-2	DIOD ZNR 15V 1W SILICON EPIT	2	D8, D15
QD-000206-GP	4804-9340-2	DIOD RECT FAST, IN4934 AT	2	D108, D109
QD-000207-GP	4860-5020-5	XISTOR NPN 250V 0.5A MJE15032	1	Q105
QD-000208-GP	4860-5060-5	TR 2SA1943 TO-3P (L)	3	Q103, Q107, Q109, Q111
QD-000209-GP	4860-5050-5	TR 2SC5200 TO-3P (L)	3	Q104, Q108, Q110, Q112
QD-000210-GP	4860-5030-5	XISTOR PNP 250V MJE15033	1	Q106
QD-000211-GP	4860-8890-0	TR MPS A06VCE 80V NS	1	Q5
QD-000212-GP	4837-5B10-2	DIODE ZENER 1/2W 5.5-5.8V	2	D107, D110 (December 2003 and earlier)
QD-000269-GP	*	DIODE ZENER 5.1V 5% .25W DO-35	2	D107, D110 (January 2004 and later)
RE-.02201-GP	471A-022K-5-N	0.22 OHM 5% 3W THK FLM	8	R142, R143, R148, R149, R152, R153, R156, R159
RE-.56006-GP	4719-5R6J-1-X	RMF 2W 5.6 OHM 5%	1	R160
RE-.68001-GP	4718-6R8J-1-X	RMF 1W 6.8 OHM 5%	2	R146, R147
RE-000250-GP	8910-0488-0	NTC RES 50 OHM	1	R134
RE-000260-GP	8910-0274-0	THERMAL PTC 60C 100 OHM	1	R7
RE-001201-GP	471B-120J-1-X	12 5% 5W METAL OXIDE FILM	2	R161, R162
RE-002202-GP	4718-220J-2-P	RMF 1W 22 5% AT FP	2	R136, R137
RE-110011-GP	471B-102J-1-X	RMF 5W 1K 5%	2	R157, R158
RE-122006-GP	4756-2226-3-06	SVR 2.2K H3 7X7	2	R139, R140



## RMX1450 Channel 1 module (continued)

QSC part #	Old QSC part #	Description	Qty.	Notes or Component Reference
RE-130003-GP	471B-302J-1-X	RMF 5W 3K 5% METAL	2	R133, R135
RE-215006-GP	4719-153J-1-X	RMF 2W 15K 5% AL METAL	2	R2, R5
XF-000190-GP	1804-1040-0	SPRING COIL 2UH (14GA WIRE)	1	L100

### Channel 1 SMT parts

CA-210011-GP	150H-102J-6-CF	CC 100V 0.001U 5% 1206	1	C114
CA-222007-GP	150F-222K-6-CF	50V .0022UF 10% 1206	1	C115
QD-000201-GP	4804-1480-3	DIODE LL4148 SM	15	D2-D7, D9, D14, D104, D111-D116
QD-000204-GP	4860-0640-3	XISTOR NPN 60V 200MA 3904 SOT-23	4	Q8, Q9, Q101, Q102
QD-000205-GP	4853-9060-3	XISTOR PNP 40V 0.2A TR3906 SOT-23	3	Q4, Q6, Q7
QD-000213-GP	4860-5110-3	TR KST42	1	Q1
RE-004702-GP	4720-470J-J	RMG 1/10W 47 OHM 5% 0805	2	R25, R124
RE-082003-GP	4721-821J-6	RMG 1/8W 820 OHM 5% 1206	2	R130, R132
RE-115004-GP	4720-152J-J	RMG 1/10W 1.5K 5% 0805	1	R129
RE-120004-GP	4720-202J-J	RMG 1/10W 2K 1% 0805 [here]	1	R8
RE-168002-GP	4721-682J-6	RCF 1/8W 6.8K 5% ATS	1	R19
RE-210006-GP	4720-103J-J	RMG 1/10W 10K 5% 0805	1	R128
RE-247004-GP	4721-473J-6	RMG 1/8W 47K 5% 1206	1	R125
RE-315003-GP	4721-154J-6	RMG 1/8W 150K 5% 1206	1	R10
RE-322001-GP	4721-224J-6	RMG 1/8W 220K 5% 1206	2	R18, R27
RE-322002-GP	4720-224J-J	RMG 1/10W 220K 5% 0805	1	R26
RE-347002-GP	4721-474J-6	RMF 1/8W 470K 5% ATS	1	R15
RE-410002-GP	4721-105J-6	RMG 1/8W 1M 5% 1206	2	R3, R6

## WP-014503-00 Channel 2 Module Assembly (right) (was PCB-QZ020C-PWR2)

CA-233004-GP	153F-332J-5-KW	CM 50V .0033UF 5% RL	2	C217, C218
CA-322006-GP	153F-223J-5-LQ	CM 50V .022UF 5% RL	2	C216, C219
CA-368004-GP	153R-683J-5-WMM	0.068UF 5% 250V FILM DIPPED	1	C224
CA-415004-GP	153F-154J-5-NLM	0.15U,5%,50V,CM,,RBT,7.5X	4	C108, C109, C208, C209
CA-422006-GP	153F-224J-5-NLM	CM 50V 0.22UF 5% RL	2	C107, C207
CA-610020-GP	157F-106M-5-LUN	CE 50V 10UF 20% RLT 5 X 11	2	C106, C206
CA-710009-GP	157E-107M-5-KW	CE 25V 100UF 20% RL	2	C105, C205
CA-722006-GP	157E-227M-5-PU	CE 25V 220uF 20% RL	4	C112, C113, C212, C213
CA-833002-GP	8910-0272-0	3300UF 20% 100V ELECT RAD	4	C220-C223
CO-000222-GP	2101-1991-0	8-PIN IC SOCKET	2	REF: U101, U201
IC-000211-GP	3130-2430-0	IC NE5532 OP AMP	2	U101, U201
PT-110002-GP	4756-1016-3-06	TRIM POT,100,20 PCNT,0.15W,,	1	R231
*PT-225000-GP	*4751-0110-0	RES VAR 2.5K RT ANGLE PCB	2	R112, R212 (May 2002 and later)
*PT-310006-GP	*4750-6200-0	VR V012CPH, D-SHAFT 10K	2	R112, R212 (April 2002 and earlier)
QD-000197-GP	3700-4529-R	LED 4.7MM RED W/STAND	2	LD100, LD200
QD-000199-GP	3700-4530-Y	LED 4.7MM W/STAND YELLOW	2	LD101, LD201
QD-000202-GP	4804-0040-1	DIODE IN4004 AL	4	D10, D13, D217, D218
QD-000203-GP	4838-15V6-2	DIOD ZNR 15V 1W SILICON EPIT	4	D100, D101, D200, D201
QD-000206-GP	4804-9340-2	DIOD RECT FAST, IN4934 AT	2	D208, D209
QD-000207-GP	4860-5020-5	XISTOR NPN 250V 0.5A MJE15032	1	Q205
QD-000208-GP	4860-5060-5	TR 2SA1943 T0-3P (L)	3	Q203, Q207, Q209, Q211
QD-000209-GP	4860-5050-5	TR 2SC5200 T0-3P (L)	3	Q204, Q208, Q210, Q212
QD-000210-GP	4860-5030-5	XISTOR PNP 250V MJE15033	1	Q206
QD-000212-GP	4837-5B10-2	DIODE ZENER 1/2W 5.5-5.8V	2	D207, D210 (December 2003 and earlier)
QD-000269-GP	*	DIODE ZENER 5.1V 5% .25W DO-35	2	D207, D210 (January 2004 and later)
RE-.02201-GP	471A-022K-5-N	0.22 OHM 5% 3W THK FLM	8	R242, R243, R248, R249, R252, R253, R256, R259
RE-.56006-GP	4719-5R6J-1-X	RMF 2W 5.6 OHM 5%	1	R260
RE-.68001-GP	4718-6R8J-1-X	RMF 1W 6.8 OHM 5%	3	R20, R246, R247
RE-000250-GP	8910-0488-0	NTC RES 50 OHM	1	R234
RE-000260-GP	8910-0274-0	THERMAL PTC 60C 100 OHM	1	R4
RE-001201-GP	471B-120J-1-X	12 5% 5W METAL OXIDE FILM	2	R261, R262
RE-002202-GP	4718-220J-2-P	RMF 1W 22 5% AT FP	2	R236, R237
RE-110011-GP	471B-102J-1-X	RMF 5W 1K 5%	2	R257, R258
RE-122006-GP	4756-2226-3-06	SVR 2.2K H3 7X7	2	R239, R240
RE-130003-GP	471B-302J-1-X	RMF 5W 3K 5% METAL	2	R233, R235
RE-211304-GP	4717-1132-2	RMF 1/2W 11.3K 1% AT	1	R123

## RMX1450 Channel 2 module (continued)

QSC part #	Old QSC part #	Description	Qty.	Notes or Component Reference
RE-213304-GP	4717-1332-2	RMF 1/2W 13.3K 1% AT	2	R122, R222
XF-000190-GP	1804-1040-0	SPRING COIL 2UH (14GA WIRE)	1	L200

### Channel 2 SMT Parts

CA-056001-GP	150F-560K-J-BD	CC 50V 56PF 10% 0805	2	C110, C210
CA-056002-GP	15CG-560J-6-CF	CTC 0/30 56P 5% 1206	2	C111, C211
CA-118000-GP	150F-181K-J-BD	CC 50V 180PF 5% 0805	4	C101, C103, C201, C203
CA-210011-GP	150H-102J-6-CF	CC 100V 0.001U 5% 1206	1	C214
CA-222007-GP	150F-222K-6-CF	50V .0022UF 10% 1206	1	C215
CA-410013-GP	150F-104K-6-CF	CER 2 1206 10% 50V .1UF	3	C100, C102, C104
IC-000212-GP	3131-9730-0	IC NE5517D	1	U10
QD-000201-GP	4804-1480-3	DIODE LL4148 SM	15	D102, D103, D105, D106, D202-D206, D211-D216
QD-000204-GP	4860-0640-3	XISTOR NPN 60V 200MA 3904 SOT-23	2	Q201, Q202
QD-000205-GP	4853-9060-3	XISTOR PNP 40V 0.2A TR3906 SOT-23	2	Q100, Q200
RE-004702-GP	4720-470J-J	RMG 1/10W 47 OHM 5% 0805	1	R224
RE-010006-GP	4720-101J-J	RMG 1/10W 100 5%	6	R109, R110, R127, R209, R211, R227
RE-027003-GP	4720-271J-J	RMG 1/10W 270 OHM 5%	6	R111, R113, R120, R210, R213, R220
RE-082003-GP	4721-821J-6	RMG 1/8W 820 OHM 5% 1206	4	R115, R215, R230, R232
RE-110012-GP	4720-102J-J	RMG 1/10W 1K 5% 0805	3	R102, R126, R202
RE-115004-GP	4720-152J-J	RMG 1/10W 1.5K 5% 0805	1	R229
RE-133007-GP	4720-332J-J	RMG 1/10W 3.3K 5% 0805	1	R24
RE-147001-GP	4720-472J-J	RMG 1/10W 4.7K 5% 0805	2	R114, R214
RE-175003-GP	4720-752J-J	RMG 1/10W 7.5K 5% 0805	2	R108, R208
RE-210006-GP	4720-103J-J	RMG 1/10W 10K 5% 0805	3	R103, R203, R228
RE-210007-GP	4720-103A-J	10K 1% 1/10W THK FLM 0805	8	R100, R101, R105, R106, R200, R201, R205, R206
RE-220005-GP	4720-203A-J	RMG 1/10W 20K 1% 0805	4	R117, R121, R217, R221
RE-233001-GP	4721-333J-6	RMG 1/8W 33K 1% 1206 [here]	2	R22, R23
RE-239001-GP	4720-393J-J	RMG 1/10W 39K 5% 0805	2	R107, R207
RE-247004-GP	4721-473J-6	RMG 1/8W 47K 5% 1206	1	R225
RE-315004-GP	4721-154A-6	RMG 1/8W 150K 1% 1206	4	R118, R119, R218, R219
RE-315003-GP	4721-154J-6	RMG 1/8W 150K 5% 1206	2	R104, R204
RE-349901-GP	4721-4993-6	499K 1% 1/8W THICK FILM 1206	2	R116, R216

### Input Board Assembly (was PCB-QZ020C-INP)

CA-147006-GP	150F-471J-5-OF	470PF 5% 50V CER NPO	4	C1, C2, C3, C4
CO-000204-GP	2113-1337-1	CONN XLR F VERT PLASTIC	2	J101, J201
CO-000235-GP	2113-1652-0	PHONE JACK 06.4	2	J102, J202
SW-000089-GP	5200-4713-0	10 POLE DIP SWITCH	1	SW1
WC-000194-GP	7010-9860-0	RIBBON CABLE 26 PIN IEC	1	J1

### Output Board Assembly (was PCB-QZ020C-OUT)

CO-000236-GP	2113-1336-1	SPEAKON NEUTRIK 4 WIRE	2	J100, J200
PA-000043-00	2113-1338-0	PLATE ASSY, PLX/RMX, OUTPUT,,	1	J103
PL-000055-00	4154-2111-0	OUTPUT POST PLUG FOR CE (RED)	2	For European models only
PL-000056-00	4154-2121-0	OUTPUT POST PLUG FOR CE (BLACK)	2	For European models only

## 6.3 RMX1850HD Replacement Parts

QSC part #	Old QSC part #	Description	Qty.	Notes or Component Reference
<b>Misc.</b>				
CH-000194-GP	4134-9101-0	FAN SHROUD RMX	1	
CO-000211-GP	2113-1144-0	AC INLET 250V 15A	1	
MS-000137-GP	4154-0361-0	FAN GUARD WIRE 76MM RMX	1	
MS-000138-GP	8900-9050-1	DC FAN 24V 80X80 (+5V)	1	
SW-000088-GP	5200-4717-0	ROCKER POWER SWITCH	1	
SW-000091-GP	5200-3531-0	CIRCUIT BREAKER 15A	1	For 120V models
SW-000094-GP	5200-4731-0	CIRCUIT BREAKER 8A	1	For 230V models
WC-000181-GP	7010-9640-0	AC CORD 15A, 14 AWG, ISA	1	For 120V models
WC-000213-GP	7009-8620-0	AC CORD 8A, CE	1	For 230V models
*XF-000105-GP	1806-2440-0	XFMR RMX 1850	1	Discontinued; replaced by XF-000320-GP and XF-000321-GP
XF-000320-GP	1806-3989+0000	TRANSFORMER, 240V, RMX1850HD	1	For 230V models
XF-000321-GP	1806-3988+0000	TRANSFORMER, 120V, RMX1850HD	1	For 120V models

### AC Board Assembly (was PCB-QZ101C-PSU)

CA-422005-GP	153R-224K-5-Y1	CM 250V .22UF 10% RL	4	C127, C128, C227, C228
CA-810006-GP	157Q-108M-5-X9E	1000UF 35V 20% ELECTROLYTIC	1	C6
	153T-473K-5-WS	CM 400V 0.047UF 10% RL	1	C10
IC-000213-GP	3130-9270-0	IC 4N29	1	U2
MS-000125-GP	5400-1831-1	HEATSINK FOR RECTIFIER	4	REF: BR100, BR101, BR200, BR201
MS-000126-GP	5400-0831-0	HEATSINK, BRIDGE RECTIFIER	1	REF: Q3
QD-000200-GP	4840-1760-0	DIODE RECT 1A 200V DB103	1	BR1
QD-000214-GP	4860-2620-5	TR TIP31C SAMSUNG	1	Q3
QD-000227-GP	4840-2150-0	BRIDGE RECT 400V 25A	4	BR100, BR101, BR200, BR201
RE-000005-GP	8910-0273-0	POLYSWITCH 1.1A 0.15 OHM 1.5W	1	R1
RE-000270-GP	8910-0275-0	NTC 30A 1 OHM	1	R21
RE-001201-GP	471B-120J-1-X	12 5% 5W METAL OXIDE FILM	2	R28, R29
RE-012004-GP	4719-121J-1-X	RMF 2W 120 OHM 5%	1	R17
RE-120003-GP	4701-202J-C	RCF 1/8W 2K 5% ATS	1	R13
RE-168002-GP	4701-682J-C	RCF 1/8W 6.8K 5% ATS	2	R9, R14
	4701-474J-C	RCF 1/8W 470K 5% ATS	1	R12

### WP-018504-00 Channel 1 Module Assembly (right) (was PCB-QZ100C-PWR2)

CA-210012-GP	153H-102J-5-IQ	CM 100V .001UF 5% RL 5X	2	C131, C231
CA-215004-GP	153R-152J-5-XQ	CM 250V .0015UF 5% RL	1	C114
CA-233004-GP	153F-332J-5-KW	CM 50V .0033UF 5% RL	2	C172, C179
CA-322006-GP	153F-223J-5-LQ	CM 50V .022UF 5% RL	2	C116, C119
CA-368004-GP	153R-683J-5-WMM	0.068UF 5% 250V FILM DIPPED	2	C124, C126
CA-410018-GP	153R-104J-5-YRM	CM 250V .1UF 5% RL	2	C174, C175
CA-415004-GP	153F-154J-5-NLM	0.15U,5%,50V,CM,,RBT,7.5X	4	C108, C109, C208, C209
CA-422006-GP	153F-224J-5-NLM	CM 50V 0.22UF 5% RL	2	C107, C207
CA-610009-GP	157Q-106M-5-IU	CE 35V 10UF 20% RL 5 X 11	1	C171
CA-622007-GP	157E-226M-5-IUN	CE 25NP 22UF 20% RL 5X11	1	C129
CA-647006-GP	157D-476M-5-LUN	CE 16NP 47UF 20% RL	2	C106, C206
CA-710009-GP	157E-107M-5-KW	CE 25V 100UF 20% RL	4	C105, C173, C180, C205
CA-710010-GP	157D-107M-5-OUN	CE 16NP 100UF 20% RL 8X11	2	C125, C225
CA-722006-GP	157E-227M-5-PU	CE 25V 220uF 20% RL	4	C112, C113, C212, C213
CA-912001-GP	8910-0494-0	12000UF,20 PCNT,63V,CE,RL,,	4	C120-C123
CO-000217-GP	2102-130S-003	CONN 13 PIN STRAIGHT WAFER	1	J104
CO-000222-GP	2101-1991-0	8-PIN IC SOCKET	2	REF: U101, U201
CO-000223-GP	2101-2081-0	26-PIN DUAL ROW IEC	1	J103
HW-000020-GP	4134-8851-0	FUSE HOLDER 6.3MM	2	F100
IC-000211-GP	3130-2430-0	IC NE5532 OP AMP	2	U101, U201
MS-000127-GP	5120-0501-0	FUSE T20A/125V 6.4X32MM	1	F100
PT-110002-GP	4756-1016-3-06	TRIM POT,100,20 PCNT,0.15W,,	1	R131
PT-225000-GP	4751-0110-0	RES VAR 2.5K RT ANGLE PCB	2	R112, R212
QD-000197-GP	3700-4529-R	LED 4.7MM RED W/STAND	2	LD100, LD200
QD-000199-GP	3700-4530-Y	LED 4.7MM W/STAND YELLOW	2	LD101, LD201

## RMX1850HD Channel 1 module (continued)

QSC part #	Old QSC part #	Description	Qty.	Notes or Component Reference
QD-000202-GP	4804-0040-1	DIODE IN4004 AL	4	D10, D12, D117, D118
QD-000203-GP	4838-15V6-2	DIOD ZNR 15V 1W SILICON EPIT	4	D100, D101, D200, D201
QD-000206-GP	4804-9340-2	DIOD RECT FAST, IN4934 AT	2	D108, D109
QD-000207-GP	4860-5020-5	XISTOR NPN 250V 0.5A MJE15032	1	Q105
QD-000208-GP	4860-5060-5	TR 2SA1943 T0-3P (L)	3	Q103, Q107, Q109, Q111
QD-000209-GP	4860-5050-5	TR 2SC5200 T0-3P (L)	3	Q104, Q108, Q110, Q112
QD-000210-GP	4860-5030-5	XISTOR PNP 250V MJE15033	1	Q106
*QD-000212-GP	4837-5B10-2	DIODE ZENER 1/2W 5.5-5.8	2	D107, D110 (December 2003 and earlier)
QD-000215-GP	4840-2190-0	DIODE MUR1520 15A 200V	2	D175, D176
QD-000218-GP	4837-3B20-2	DIOD ZNR 3.8-4.0V 1/2 HZ SER	1	D170
QD-000219-GP	4838-10V6-2	DIODE ZENER 1.3W 10V TEMIC	1	D174
QD-000220-GP	4838-12V6-2	DIODE ZENER 1W 12V AT TEMIC	1	D178
*QD-000221-GP	8910-0482-0	SRV-TRIAC 600V 40A MAC224 A8	1	Q113 (replaced by SG-000522-00 kit)
*QD-000261-GP	*	TRIAC 600V 40A BTA41-600B, TOP3	1	Q113 (part of SG-000522-00 kit for replacing MAC224 triac)
*QD-000269-GP	*	DIODE ZENER 5.1V 5% .25W DO-35	2	D107, D110 (January 2004 and later)
QD-000347-GP	490F-Z440-5	FETN, 60V, 50A, 150W, , ,	2	Q170, Q174
QD-000350-10	4860-5250-5	TR 2N5064 SCR	2	D119, D120
RE-.02201-GP	471A-022K-5-N	0.22 OHM 5% 3W THK FLM	8	R142, R143, R148, R149, R152, R153, R156, R159
RE-.15003-GP	4719-1R5J-1-X	1.5 OHM 5% 2W THK FLM	2	R181, R182
RE-.33001-GP	4718-3R3J-1-X	RMF 1W 3.3 OHM 5%	3	R146, R147, R20
RE-.56006-GP	4719-5R6J-1-X	RMF 2W 5.6 OHM 5%	1	R160
RE-000250-GP	8910-0488-0	NTC RES 50 OHM	1	R134
RE-000260-GP	8910-0274-0	THERMAL PTC 60C 100 OHM	1	R4
RE-001005-GP	4715-100J-2	RMF 1/4W 10 OHM 5%	1	R163
RE-001201-GP	471B-120J-1-X	12 5% 5W METAL OXIDE FILM	4	R154, R155, R161, R162
RE-002202-GP	4718-220J-2-P	RMF 1W 22 5% AT FP	2	R136, R137
RE-010008-GP	4715-101J-2	RMF 1/4W 100 OHM 5%	1	R164
RE-122006-GP	4756-2226-3-06	SVR 2.2K H3 7X7	2	R139, R140
RE-122008-GP	471B-222J-1-X	RMF 5W 2.2K 5% METAL	3	R157, R158, R198
RE-151003-GP	471B-512J-1-X	RMF 5W 5.1K 5% AL METAL	2	R180, R188
RE-182002-GP	471B-822J-1-X	RMF 5W 8.2K 5% AL METAL	4	R118, R119, R133, R135
RE-212002-GP	4718-123J-2-X	RMF 1W 12K 5% AT METAL	2	R177, R194
RE-215007-GP	4718-153J-2-X	RMF 1W 15K 5% METAL	1	R165
RE-223202-GP	4717-2322-2	RMF 1/2W 23.2K 1% AT	3	R122, R123, R222
XF-000190-GP	1804-1040-0	SPRING COIL 2UH (14GA WIRE)	1	L100

## Channel 1 SMT parts

CA-047005-GP	150F-470J-J-BD	CC 50V 47PF 5% 0805	5	C110, C170, C176, C177, C210
CA-110004-GP	150F-101K-J-BD	CC 50V 100P 10% 0805	1	C132
CA-110005-GP	150F-101J-J-BD	CC 50V 100PF 5% 0805 1.2	1	C130
CA-118000-GP	150F-181K-J-BD	CC 50V 180PF 5% 0805	4	C101, C103, C201, C203
CA-222007-GP	150F-222K-6-CF	50V .0022UF 10% 1206	1	C115
CA-310009-GP	150F-103M-J-BD	CC 50V 0.01uF 20% 0805 1	1	C181
CA-410016-GP	150F-104M-6-CF	CC 50V 0.1uF 20% 1206 1.	2	C104, C178
	15CG-270J-6-CF	CTC 0/30 27P 5% 1206	2	C111, C211
IC-000212-GP	3131-9730-0	IC NE5517D	1	U10
IC-000214-GP	3130-9240-0	LM311M VOLTAGE	2	U170, U171
QD-000201-GP	4804-1480-3	DIODE LL4148 SM	18	D102-D106, D111-D116, D171, D173, D177, D202, D203, D205, D206
QD-000204-GP	4860-0640-3	XISTOR NPN 60V 200MA 3904 SOT-23	4	Q101, Q102, Q171, Q173
QD-000205-GP	4853-9060-3	XISTOR PNP 40V 0.2A TR3906 SOT-23	4	Q100, Q172, Q175, Q200
RE-004702-GP	4720-470J-J	RMG 1/10W 47 OHM 5% 0805	2	R170, R189
RE-007506-GP	4720-750J-J	RMG 1/10W 75 OHM 5% 0805	1	R124
RE-010006-GP	4720-101J-J	RMG 1/10W 100 5%	6	R109, R110, R127, R209, R210, R227
RE-027003-GP	4720-271J-J	RMG 1/10W 270 OHM 5%	4	R113, R196, R213, R296
RE-039001-GP	4720-391J-J	RMG 1/10W 390R 5% 0805	2	R120, R220
RE-082003-GP	4721-821J-6	RMG 1/8W 820 OHM 5% 1206	4	R115, R130, R132, R215
RE-082004-GP	4720-821J-J	RMG 1/10W 820R 5% 0805	2	R111, R211
RE-110012-GP	4720-102J-J	RMG 1/10W 1K 5% 0805	3	R102, R126, R202
RE-115004-GP	4720-152J-J	RMG 1/10W 1.5K 5% 0805	1	R129

## RMX1850HD Channel 1 module (continued)

QSC part #	Old QSC part #	Description	Qty.	Notes or Component Reference
RE-120004-GP	4720-202J-J	RMG 1/10W 2K 1% 0805	2	R190, R195
RE-122007-GP	4720-222J-J	RMG 1/10W 2.2K 5% 0805	1	R191
RE-130103-GP	4720-3011-J	RMG 1/10W 3.01K 1% 0805	2	R24, R175
RE-147001-GP	4720-472J-J	RMG 1/10W 4.7K 5% 0805	8	R114, R138, R174, R179, R187, R193, R214, R238
RE-159003-GP	4720-592A-J	5.9K 1% 1/10W THK FLM 0805	2	R171, R184
RE-175003-GP	4720-752J-J	RMG 1/10W 7.5K 5% 0805	2	R108, R208
RE-210006-GP	4720-103J-J	RMG 1/10W 10K 5% 0805	3	R103, R128, R203
RE-210007-GP	4720-103A-J	10K 1% 1/10W THK FLM 0805	8	R100, R101, R105, R106, R200, R201, R205, R206
RE-212001-GP	4720-123J-J	RMG 1/10W 12K 5% 0805	1	R176
RE-224001-GP	4720-243J-J	24.0K 1% 1/10W THK FLM 0805	4	R117, R121, R217, R221
RE-239001-GP	4720-393J-J	RMG 1/10W 39K 5% 0805	2	R107, R207
RE-247004-GP	4721-473J-6	RMG 1/8W 47K 5% 1206	1	R125
RE-247005-GP	4720-473J-J	RMG 1/10W 47K 5% 0805	1	R183
RE-268003-GP	4721-683A-6	RMG 1/8W 68K 1% 1206	4	R22A, R22B, R23A, R23B
RE-315003-GP	4721-154J-6	RMG 1/8W 150K 5% 1206	6	R104, R173, R178, R186, R192, R204
RE-346401-GP	4721-4643-6	464K 1% 1/8W THK FLM 1206	3	R166, R167, R266
RE-347003-GP	4720-474J-J	RMG 1/10W 470K 5% 0805	2	R172, R185
	4721-101J-6	RMG 1/8W 100R 5% 1206	1	R197
	4721-824J-6	RMG 1/8W 820K 5% 1206	2	R116, R216

## WP-018503-00 Channel 2 Module Assembly (left) (was PCB-QZ100C-PWR1)

CA-215004-GP	153R-152J-5-XQ	CM 250V .0015UF 5% RL	1	C214
CA-233004-GP	153F-332J-5-KW	CM 50V .0033UF 5% RL	2	C272, C279
CA-322006-GP	153F-223J-5-LQ	CM 50V .022UF 5% RL	2	C216, C219
CA-368004-GP	153R-683J-5-WMM	0.068UF 5% 250V FILM DIPPED	2	C224, C226
CA-410018-GP	153R-104J-5-YRM	CM 250V .1UF 5% RL	2	C274, C275
CA-622007-GP	157E-226M-5-IUN	CE 25NP 22UF 20% RL 5X11	1	C229
CA-647005-GP	157F-476M-5-LU	CE 50V 47UF 20% RL	1	C8
CA-610009-GP	157Q-106M-5-IU	CE 35V 10UF 20% RL 5 X 11	1	C271
CA-710009-GP	157E-107M-5-KW	CE 25V 100UF 20% RL	2	C273, C280
CA-547008-GP	157R-475M-5-OV	4.7UF 20% 250V ELECTRO RAD	1	C7
CA-912001-GP	8910-0494-0	12000UF, 20 PCNT, 63V, CE, RL, ,	4	C220-C223
CO-000214-GP	2102-031S-004	CONN 3 PIN STRAIGHT WAFER	1	J257
CO-000217-GP	2102-130S-003	CONN 13 PIN STRAIGHT WAFER	1	J204
HW-000020-GP	4134-8851-0	FUSE HOLDER 6.3MM	2	REF: F200
MS-000127-GP	5120-0501-0	FUSE T20A/125V 6.4X32MM	1	F200
PT-110002-GP	4756-1016-3-06	TRIM POT, 100, 20 PCNT, 0.15W, ,	1	R231
QD-000198-GP	3700-4531-G	LED 4.7MM GRN W/STAND	1	LD1
QD-000202-GP	4804-0040-1	DIODE IN4004 AL	5	D1, D11, D13, D217, D218
QD-000203-GP	4838-15V6-2	DIOD ZNR 15V 1W SILICON EPIT	2	D8, D15
QD-000206-GP	4804-9340-2	DIOD RECT FAST, IN4934 AT	2	D208, D209
QD-000207-GP	4860-5020-5	XISTOR NPN 250V 0.5A MJE15032	1	Q205
QD-000208-GP	4860-5060-5	TR 2SA1943 TO-3P (L)	3	Q203, Q207, Q209, Q211
QD-000209-GP	4860-5050-5	TR 2SC5200 TO-3P (L)	3	Q204, Q208, Q210, Q212
QD-000210-GP	4860-5030-5	XISTOR PNP 250V MJE15033	1	Q206
QD-000211-GP	4860-8890-0	TR MPS A06VCE 80V NS	1	Q5
*QD-000212-GP	4837-5B10-2	DIODE ZENER 1/2W 5.5-5.8V	2	D207, D210 (December 2003 and earlier)
QD-000215-GP	4840-2190-0	DIODE MUR1520 15A 200V	2	D275, D276
QD-000218-GP	4837-3B20-2	DIOD ZNR 3.8-4.0V 1/2 HZ SER	1	D270
QD-000219-GP	4838-10V6-2	DIODE ZENER 1.3W 10V TEMIC	1	D274
QD-000220-GP	4838-12V6-2	DIODE ZENER 1W 12V AT TEMIC	1	D278
*QD-000221-GP	8910-0482-0	SRV-TRIAC 600V 40A MAC224 A8	1	Q213 (replaced by SG-000522-00 kit)
*QD-000269-GP	*	DIODE ZENER 5.1V 5% .25W DO-35	2	D207, D210 (January 2004 and later)
QD-000347-GP	490F-Z440-5	FETN, 60V, 50A, 150W, , ,	2	Q270, Q274
QD-000350-10	4860-5250-5	TR 2N5064 SCR	2	D219, D220
RE-.02201-GP	471A-022K-5-N	0.22 OHM 5% 3W THK FLM	8	R242, R243, R248, R249, R252, R253, R256, R259
RE-.15003-GP	4719-1R5J-1-X	1.5 OHM 5% 2W THK FLM	2	R281, R282
RE-.33001-GP	4718-3R3J-1-X	RMF 1W 3.3 OHM 5%	2	R246, R247
RE-.56006-GP	4719-5R6J-1-X	RMF 2W 5.6 OHM 5%	1	R260
RE-000250-GP	8910-0488-0	NTC RES 50 OHM	1	R234
RE-000260-GP	8910-0274-0	THERMAL PTC 60C 100 OHM	1	R7

**RMX1850HD Channel 2 module (continued)**

QSC part #	Old QSC part #	Description	Qty.	Notes or Component Reference
RE-001201-GP	471B-120J-1-X	12 5% 5W METAL OXIDE FILM	4	R254, R255, R261, R262
RE-002202-GP	4718-220J-2-P	RMF 1W 22 5% AT FP	2	R236, R237
RE-001005-GP	4715-100J-2	RMF 1/4W 10 OHM 5%	1	R263
RE-010008-GP	4715-101J-2	RMF 1/4W 100 OHM 5%	1	R264
RE-122006-GP	4756-2226-3-06	SVR 2.2K H3 7X7	2	R239, R240
RE-122008-GP	471B-222J-1-X	RMF 5W 2.2K 5% METAL	3	R257, R258, R298
RE-151003-GP	471B-512J-1-X	RMF 5W 5.1K 5% AL METAL	2	R280, R288
RE-182002-GP	471B-822J-1-X	RMF 5W 8.2K 5% AL METAL	4	R218, R219, R233, R235
RE-212002-GP	4718-123J-2-X	RMF 1W 12K 5% AT METAL	2	R277, R294
RE-215007-GP	4718-153J-2-X	RMF 1W 15K 5% METAL	1	R265
RE-233002-GP	4719-333J-2-X	RMF 2W 33K 5% METAL	2	R2, R5
XF-000190-GP	1804-1040-0	SPRING COIL 2UH (14GA WIRE)	1	L200

**Channel 2 SMT Parts**

CA-047005-GP	150F-470J-J-BD	CC 50V 47PF 5% 0805	3	C270, C276, C277
CA-110004-GP	150F-101K-J-BD	CC 50V 100P 10% 0805	1	C9
CA-222007-GP	150F-222K-6-CF	50V .0022UF 10% 1206	1	C215
CA-310009-GP	150F-103M-J-BD	CC 50V 0.01uF 20% 0805 1	1	C281
CA-410014-GP	150F-104M-J-BD	0.1UF 10% 50V CER X7R 0805	1	C11
CA-410016-GP	150F-104M-6-CF	CC 50V 0.1uF 20% 1206 1.	1	C278
IC-000214-GP	3130-9240-0	LM311M VOLTAGE	2	U270, U271
QD-000201-GP	4804-1480-3	DIODE LL4148 SM	18	D2-D7, D9, D14, D204, D211-D216, D271, D273, D277
QD-000204-GP	4860-0640-3	XISTOR NPN 60V 200MA 3904 SOT-23	6	Q8, Q9, Q201, Q202, Q271, Q273
QD-000205-GP	4853-9060-3	XISTOR PNP 40V 0.2A TR3906 SOT-23	5	Q4, Q6, Q7, Q272, Q275
QD-000213-GP	4860-5110-3	TR KST42	1	Q1
RE-004702-GP	4720-470J-J	RMG 1/10W 47 OHM 5% 0805	3	R25, R270, R289
RE-007506-GP	4720-750J-J	RMG 1/10W 75 OHM 5% 0805	1	R224
RE-082003-GP	4721-821J-6	RMG 1/8W 820 OHM 5% 1206	2	R230, R232
RE-115004-GP	4720-152J-J	RMG 1/10W 1.5K 5% 0805	1	R229
RE-120004-GP	4720-202J-J	RMG 1/10W 2K 1% 0805	3	R8, R290, R295
RE-122007-GP	4720-222J-J	RMG 1/10W 2.2K 5% 0805	1	R291
RE-130103-GP	4720-3011-J	RMG 1/10W 3.01K 1% 0805	1	R275
RE-147001-GP	4720-472J-J	RMG 1/10W 4.7K 5% 0805	4	R274, R279, R287, R293
RE-159003-GP	4720-592A-J	5.9K 1% 1/10W THK FLM 0805	2	R271, R284
RE-168002-GP	4721-682J-6	RCF 1/8W 6.8K 5% ATS	1	R19
RE-210006-GP	4720-103J-J	RMG 1/10W 10K 5% 0805	1	R228
RE-212001-GP	4720-123J-J	RMG 1/10W 12K 5% 0805	1	R276
RE-247004-GP	4721-473J-6	RMG 1/8W 47K 5% 1206	1	R225
RE-247005-GP	4720-473J-J	RMG 1/10W 47K 5% 0805	1	R283
RE-315003-GP	4721-154J-6	RMG 1/8W 150K 5% 1206	5	R10, R273, R278, R286, R292
RE-322001-GP	4721-224J-6	RMG 1/8W 220K 5% 1206	2	R18, R26
RE-330001-GP	4721-334J-6	RMG 1/8W 330K 5% 1206	1	R27
RE-346401-GP	4721-4643-6	464K 1% 1/8W THK FLM 1206	1	R15
RE-347003-GP	4720-474J-J	RMG 1/10W 470K 5% 0805	2	R272, R285
RE-410002-GP	4721-105J-6	RMG 1/8W 1M 5% 1206	2	R3, R6
	4721-101J-6	RMG 1/8W 100R 5% 1206	1	R30

**WP-002455-00 Input Board Assembly (was PCB-QZ100C-INP)**

CA-147006-GP	150F-471J-5-0F	470PF 5% 50V CER NPO	4	C1, C2, C3, C4
CO-000204-GP	2113-1337-1	CONN XLR F VERT PLASTIC	2	J101, J201
CO-000235-GP	2113-1652-0	PHONE JACK 06.4	2	J102, J202
SW-000089-GP	5200-4713-0	10 POLE DIP SWITCH	1	SW1
WC-000194-GP	7010-9860-0	RIBBON CABLE 26 PIN IEC	1	J1

**WP-002452-00 Output Board Assembly (was PCB-QZ100C-OUT)**

CO-000236-GP	2113-1336-1	SPEAKON NEUTRIK 4 WIRE	2	J100, J200
PA-000043-00	2113-1338-0	PLATE ASSY,PLX/RMX,OUTPUT,,	1	J103
PL-000055-00	4154-2111-0	OUTPUT POST PLUG FOR CE (RED)	2	For European models only
PL-000056-00	4154-2121-0	OUTPUT POST PLUG FOR CE (BLACK)	2	For European models only

## 6.4 RMX2450 Replacement Parts

QSC part #	Old QSC part #	Description	Qty.	Notes or Component Reference
<b>Misc.</b>				
CO-000211-GP	2113-1144-0	IEC POWER INLET	1	
CH-000194-GP	4134-9101-0	METAL WIND GUIDE	1	
MS-000137-GP	4154-0361-0	FAN GUIDE	1	
MS-000138-GP	8900-9050-1	DC FAN 24V 80X80 (+5V)	1	
SW-000088-GP	5200-4717-0	ROCKER POWER SWITCH	1	
SW-000091-GP	5200-3531-0	CIRCUIT BREAKER 15A	1	For 120V models
SW-000094-GP	5200-4731-0	CIRCUIT BREAKER 8A	1	For 230V models
WC-000181-GP	7010-9640-0	AC CORD SET 15A	1	For 120V models
WC-000213-GP	7009-8620-0	PWR CORD, 230V (EURO)	1	For 230V models
*XF-000115-GP	1806-2507-0	XFMR RMX 2450	1	Discontinued; replaced by XF-000318-GP and XF-000319-GP
XF-000318-GP	1806-3987+0000	TRANSFORMER, 240V, RMX2450	1	For 230V models
XF-000319-GP	1806-3986+0000	TRANSFORMER, 120V, RMX2450	1	For 120V models
<b>AC Board Assembly (was PCB-QZ030C-PSU)</b>				
CA-422005-GP	153R-224K-5-Y1	CM 250V .22UF 10% RL	4	C127, C128, C227, C228
CA-810006-GP	157Q-108M-5-X9E	1000UF 35V 20% ELECTROLYTIC	1	C6
	153T-473K-5-W5	CM 400V 0.047UF 10% RL	1	C10
IC-000213-GP	3130-9270-0	IC 4N29	1	U2
MS-000125-GP	5400-1831-1	HEATSINK FOR RECTIFIER	4	REF: BR100, BR101, BR200, BR201
MS-000126-GP	5400-0831-0	HEATSINK, BRIDGE RECTIFIER	1	REF: Q3
QD-000200-GP	4840-1760-0	DIODE RECT 1A 200V DB103	1	BR1
QD-000214-GP	4860-2620-5	TR TIP31C SAMSUNG	1	Q3
QD-000227-GP	4840-2150-0	BRIDGE RECT 400V 25A	4	BR100, BR101, BR200, BR201
RE-000005-GP	8910-0273-0	POLYSWITCH 1.1A 0.15 OHM 1.5W	1	R1
RE-000270-GP	8910-0275-0	NTC 30A 1 OHM	1	R21
RE-001201-GP	471B-120J-1-X	12 5% 5W METAL OXIDE FILM	2	R28, R29
RE-012004-GP	4719-121J-1-X	RMF 2W 120 OHM 5%	1	R17
RE-120003-GP	4701-202J-C	RCF 1/8W 2K 5% ATS	1	R13
RE-168002-GP	4701-682J-C	RCF 1/8W 6.8K 5% ATS	2	R9, R14
RE-210006-GP	4720-103J-J	RMG 1/10W 10K 5% 0805	4	R31-R34 (January 2002 and later)
	4701-474J-C	RCF 1/8W 470K 5% ATS	1	R12
<b>WP-002454-00 Channel 1 Module Assembly (right) (was PCB-QZ030C-PWR2)</b>				
CA-210012-GP	153H-102J-5-IQ	CM 100V .001UF 5% RL 5X	2	C131, C231
CA-215004-GP	153R-152J-5-XQ	CM 250V 0.0015UF 5% RL	1	C114
CA-233004-GP	153F-332J-5-KW	CM 50V .0033UF 5% RL	2	C172, C179
CA-322006-GP	153F-223J-5-LQ	CM 50V .022UF 5% RL	2	C116, C119
CA-368004-GP	153R-683J-5-WMM	0.068UF 5% 250V FILM DIPPED	2	C124, C126
CA-410018-GP	153R-104J-5-YRM	CM 250V .1UF 5% RL	2	C174, C175
CA-415004-GP	153F-154J-5-NLM	0.15U,5%,50V,CM,,RBT,7.5X	4	C108, C109, C208, C209
CA-422006-GP	153F-224J-5-NLM	CM 50V 0.22UF 5% RL	2	C107, C207
CA-610009-GP	157Q-106M-5-IU	CE 35V 10UF 20% RL 5 X 11	1	C171
CA-622007-GP	157E-226M-5-IUN	CE 25V 22uF 20% RL 5X11	1	C129
CA-647006-GP	157D-476M-5-LUN	CE 16NP 47UF 20% RL	2	C106, C206
CA-710009-GP	157E-107M-5-KW	CE 25V 100UF 20% RL	4	C105, C173, C180, C205
CA-710010-GP	157D-107M-5-OUN	CE 16NP 100UF 20% RL 8X11	2	C125, C225
CA-722006-GP	157E-227M-5-PU	CE 25V 220UF 20% RL	4	C112, C113, C212, C213
CA-912001-GP	8910-0494-0	12000UF,20 PCNT,63V,CE,RL,,	4	C120-C123
CO-000217-GP	2102-130S-003	CONN 13 PIN STRAIGHT WAFER	1	J104
CO-000222-GP	2101-1991-0	8-PIN IC SOCKET	2	REF: U101, U201
CO-000223-GP	2101-2081-0	26-PIN DUAL ROW IEC	1	J103
HW-000020-GP	4134-8851-0	FUSE HOLDER 6.3MM	2	F100
IC-000211-GP	3130-2430-0	IC NE5532 OP AMP	2	U101, U201
MS-000127-GP	5120-0501-0	FUSE T20A/125V 6.4X32MM	1	F100
PT-110002-GP	4756-1016-3-06	TRIM POT,100,20 PCNT,0.15W,,	1	R131
*PT-225000-GP	*4751-0110-0	RES VAR 2.5K RT ANGLE PCB	2	R112, R212 (May 2002 and later)
*PT-310006-GP	*4750-6200-0	VR V012CPH, D-SHAFT 10K	2	R112, R212 (April 2002 and earlier)
QD-000197-GP	3700-4529-R	LED 4.7MM RED W/STAND	2	LD100, LD200
QD-000199-GP	3700-4530-Y	LED 4.7MM W/STAND YELLOW	2	LD101, LD201

## RMX2450 Channel 1 module (continued)

QSC part #	Revised QSC #	Description	Qty.	Notes or Component Reference
QD-000202-GP	4804-0040-1	DIODE IN4004 AL	4	D10, D12, D117, D118
QD-000203-GP	4838-15V6-2	DIOD ZNR 15V 1W SILICON EPIT	4	D100, D101, D200, D201
QD-000206-GP	4804-9340-2	DIOD RECT FAST, IN4934 AT	2	D108, D109
QD-000207-GP	4860-5020-5	XISTOR NPN 250V 0.5A MJE15032	1	Q105
QD-000208-GP	4860-5060-5	TR 2SA1943 T0-3P (L)	3	Q103, Q107, Q109, Q111
QD-000209-GP	4860-5050-5	TR 2SC5200 T0-3P (L)	3	Q104, Q108, Q110, Q112
QD-000210-GP	4860-5030-5	XISTOR PNP 250V MJE15033	1	Q106
*QD-000212-GP	*4837-5B10-2	DIODE ZENER 1/2W 5.5-5.8V	2	D107, D110 (December 2003 and earlier)
QD-000215-GP	4840-2190-0	DIODE MUR1520 15A 200V	2	D175, D176
QD-000218-GP	4837-3B20-2	DIOD ZNR 3.8-4.0V 1/2 HZ SER	1	D170
QD-000219-GP	4838-10V6-2	DIODE ZENER 1.3W 10V TEMIC	1	D174
QD-000220-GP	4838-12V6-2	DIODE ZENER 1W 12V AT TEMIC	1	D178
*QD-000221-GP	8910-0482-0	SRV-TRIAC 600V 40A MAC224 A8	1	Q113 (replaced by SG-000522-00 kit)
*QD-000261-GP	*	TRIAC 600V 40A BTA41-600B, TOP3	1	Q113 (part of SG-000522-00 kit for replacing MAC224 triac)
*QD-000269-GP	*	DIODE ZENER 5.1V 5% .25W D0-35	2	D107, D110 (January 2004 and later)
QD-000347-GP	490F-Z440-5	FETN, 60V, 50A, 150W, , ,	2	Q170, Q174
QD-000350-10	4860-5250-5	TR 2N5064 SCR	2	D119, D120
RE-.02201-GP	471A-022K-5-N	0.22 OHM 5% 3W THK FLM	8	R142, R143, R148, R149, R152, R153, R156, R159
RE-.15003-GP	4719-1R5J-1-X	1.5 OHM 5% 2W THK FLM	2	R181, R182
RE-.33001-GP	4718-3R3J-1-X	RMF 1W 3.3 OHM 5%	3	R146, R147, R20
RE-.56006-GP	4719-5R6J-1-X	RMF 2W 5.6 OHM 5%	1	R160
RE-000250-GP	8910-0488-0	NTC RES 50 OHM	1	R134
RE-000260-GP	8910-0274-0	THERMAL PTC 60C 100 OHM	1	R4
RE-001005-GP	4715-100J-2	RMF 1/4W 10 OHM 5%	1	R163
RE-001201-GP	471B-120J-1-X	12 5% 5W METAL OXIDE FILM	4	R154, R155, R161, R162
RE-002202-GP	4718-220J-2-P	RMF 1W 22 5% AT FP	2	R136, R137
RE-010008-GP	4715-101J-2	RMF 1/4W 100 OHM 5%	1	R164
RE-122006-GP	4756-2226-3-06	SVR 2.2K H3 7X7	2	R139, R140
RE-122008-GP	471B-222J-1-X	RMF 5W 2.2K 5% METAL	3	R157, R158, R198
RE-151003-GP	471B-512J-1-X	RMF 5W 5.1K 5% AL METAL	2	R180, R188
RE-182002-GP	471B-822J-1-X	RMF 5W 8.2K 5% AL METAL	4	R118, R119, R133, R135
RE-212002-GP	4718-123J-2-X	RMF 1W 12K 5% AT METAL	2	R177, R194
RE-215007-GP	4718-153J-2-X	RMF 1W 15K 5% METAL	1	R165
RE-223202-GP	4717-2322-2	RMF 1/2W 23.2K 1% AT	3	R122, R123, R222
XF-000190-GP	1804-1040-0	SPRING COIL 2UH (14GA WIRE)	1	L100
<b>Channel 1 SMT parts</b>				
CA-027003-GP	15CG-270J-6-CF	CTC 0/30 27P 5% 1206	2	C111, C211
CA-047005-GP	150F-470J-J-BD	CC 50V 47PF 5% 0805	5	C110, C170, C176, C177, C210
CA-110004-GP	150F-101K-J-BD	CC 50V 100P 10% 0805	1	C132
CA-110005-GP	150F-101J-J-BD	CC 50V 100PF 5% 0805 1.2	1	C130
CA-118000-GP	150F-181K-J-BD	CC 50V 180PF 5% 0805	4	C101, C103, C201, C203
CA-222007-GP	150F-222K-6-CF	CC 50V 2200pF 10% 1206 1	1	C115
CA-310009-GP	150F-103M-J-BD	CC 50V 0.01uF 20% 0805 1	1	C181
CA-410016-GP	150F-104M-6-CF	CC 50V 0.1uF 20% 1206 1.	2	C104, C178
IC-000212-GP	3131-9730-0	IC NE5517D	1	U10
IC-000214-GP	3130-9240-0	LM311M VOLTAGE	2	U170, U171
QD-000201-GP	4804-1480-3	DIODE LL4148 SM	18	D102-D106, D111-D116, D171, D173, D177, D202, D203, D205, D206
QD-000204-GP	4860-0640-3	XISTOR NPN 60V 200MA 3904 SOT-23	4	Q101, Q102, Q171, Q173
QD-000205-GP	4853-9060-3	XISTOR PNP 40V 0.2A TR3906 SOT-23	4	Q100, Q172, Q175, Q200
RE-004702-GP	4720-470J-J	RMG 1/10W 47 OHM 5% 0805	2	R170, R189
RE-007506-GP	4720-750J-J	RMG 1/10W 75 OHM 5% 0805	1	R124
RE-010006-GP	4720-101J-J	RMG 1/10W 100 5%	6	R109, R110, R127, R209, R210, R227
RE-027003-GP	4720-271J-J	RMG 1/10W 270 OHM 5%	4	R113, R196, R213, R296
RE-039001-GP	4720-391J-J	RMG 1/10W 390R 5% 0805	2	R120, R220
RE-082003-GP	4721-821J-6	RMG 1/8W 820 OHM 5% 1206	4	R115, R130, R132, R215
RE-082004-GP	4720-821J-J	RMG 1/10W 820R 5% 0805	2	R111, R211
RE-110012-GP	4720-102J-J	RMG 1/10W 1K 5% 0805	3	R102, R126, R202
RE-115004-GP	4720-152J-J	RMG 1/10W 1.5K 5% 0805	1	R129
RE-120004-GP	4720-202J-J	RMG 1/10W 2K 1% 0805	2	R190, R195



## RMX2450 Channel 1 module (continued)

QSC part #	Revised QSC #	Description	Qty.	Notes or Component Reference
RE-122007-GP	4720-222J-J	RMG 1/10W 2.2K 5% 0805	1	R191
RE-130103-GP	4720-3011-J	RMG 1/10W 3.01K 1% 0805	2	R24, R175
RE-147001-GP	4720-472J-J	RMG 1/10W 4.7K 5% 0805	8	R114, R138, R174, R179, R187, R193, R214, R238
RE-159003-GP	4720-592A-J	5.9K 1% 1/10W THK FLM 0805	2	R171, R184
RE-175003-GP	4720-752J-J	RMG 1/10W 7.5K 5% 0805	2	R108, R208
RE-210007-GP	4720-103A-J	10K 1% 1/10W THK FLM 0805	8	R100, R101, R105, R106, R200, R201, R205, R206
RE-210006-GP	4720-103J-J	RMG 1/10W 10K 5% 0805	3	R103, R128, R203
RE-212001-GP	4720-123J-J	RMG 1/10W 12K 5% 0805	1	R176
RE-224001-GP	4720-243J-J	24.0K 1% 1/10W THK FLM 0805	4	R117, R121, R217, R221
RE-239001-GP	4720-393J-J	RMG 1/10W 39K 5% 0805	2	R107, R207
RE-247004-GP	4721-473J-6	RMG 1/8W 47K 5% 1206	1	R125
RE-247005-GP	4720-473J-J	RMG 1/10W 47K 5% 0805	1	R183
RE-268003-GP	4721-683A-6	RMG 1/8W 68K 1% 1206	4	R22A, R22B, R23A, R23B
RE-315003-GP	4721-154J-6	RMG 1/8W 150K 5% 1206	6	R104, R173, R178, R186, R192, R204
RE-346401-GP	4721-4643-6	464K 1% 1/8W THK FLM 1206	3	R166, R167, R266
RE-347003-GP	4720-474J-J	RMG 1/10W 470K 5% 0805	2	R172, R185
	4721-101J-6	RMG 1/8W 100R 5% 1206	1	R197
	4721-824J-6	RMG 1/8W 820K 5% 1206	2	R116, R216

## WP-002453-00 Channel 2 Module Assembly (left) (was PCB-QZ030C-PWR1)

CA-215004-GP	153R-152J-5-XQ	CM 250V 0.0015UF 5% RL	1	C214
CA-233004-GP	153F-332J-5-KW	CM 50V 3300pF 5% RL 6x12	2	C272, C279
CA-322006-GP	153F-223J-5-LQ	CM 50V .022UF 5% RL 5% RL	2	C216, C219
CA-368004-GP	153R-683J-5-WMM	0.068UF 5% 250V FILM DIPPED	2	C224, C226
CA-410018-GP	153R-104J-5-YRM	CM 250V 0.1u 5% RL	2	C274, C275
CA-547008-GP	157R-475M-5-OV	4.7UF 20% 250V ELECTRO RAD	1	C7
CA-610009-GP	157Q-106M-5-IU	CE 35V 10UF 20% RL 5 X 11	1	C271
CA-622007-GP	157E-226M-5-IUN	CE 25NP 22UF 20% RL 5X11	1	C229
CA-647005-GP	157F-476M-5-LU	CE 50V 47UF 20% RL	1	C8
CA-710009-GP	157E-107M-5-KW	CE 25V 100UF 20% RL	2	C273, C280
CA-912001-GP	8910-0494-0	12000UF, 20 PCNT, 63V, CE, RL, ,	4	C220-C223
CO-000214-GP	2102-031S-004	CONN 3 PIN STRAIGHT WAFER	1	J257
CO-000217-GP	2102-130S-003	CONN 13 PIN STRAIGHT WAFER	1	J204
QD-000198-GP	3700-4531-G	LED 4.7MM GRN W/STAND	1	LD1
HW-000020-GP	4134-8851-0	FUSE HOLDER 6.3MM	2	REF: F200
MS-000127-GP	5120-0501-0	FUSE T20A/125V 6.4X32MM	1	F200
PT-110002-GP	4756-1016-3-06	TRIM POT, 100, 20 PCNT, 0.15W, ,	1	R231
RE-.02201-GP	471A-022K-5-N	0.22 OHM 5% 3W THK FLM	8	R242, R243, R248, R249, R252, R253, R256, R259
RE-.15003-GP	4719-1R5J-1-X	1.5 OHM 5% 2W THK FLM	2	R281, R282
RE-.33001-GP	4718-3R3J-1-X	RMF 1W 3.3 OHM 5%	2	R246, R247
RE-.56006-GP	4719-5R6J-1-X	RMF 2W 5.6 OHM 5%	1	R260
RE-000250-GP	8910-0488-0	NTC RES 50 OHM	1	R234
RE-000260-GP	8910-0274-0	THERMAL PTC 60C 100 OHM	1	R7
RE-001005-GP	4715-100J-2	RMF 1/4W 10 OHM 5%	1	R263
RE-001201-GP	471B-120J-1-X	12 5% 5W METAL OXIDE FILM	4	R254, R255, R261, R262
RE-002202-GP	4718-220J-2-P	RMF 1W 22 5% AT FP	2	R236, R237
RE-010008-GP	4715-101J-2	RMF 1/4W 100 OHM 5%	1	R264
RE-122006-GP	4756-2226-3-06	SVR 2.2K H3 7X7	2	R239, R240
RE-122008-GP	471B-222J-1-X	RMF 5W 2.2K 5% METAL	3	R257, R258, R298
RE-151003-GP	471B-512J-1-X	RMF 5W 5.1K 5% AL METAL	2	R280, R288
RE-182002-GP	471B-822J-1-X	RMF 5W 8.2K 5% AL METAL	4	R218, R219, R233, R235
RE-212002-GP	4718-123J-2-X	RMF 1W 12K 5% AT METAL	2	R277, R294
RE-215007-GP	4718-153J-2-X	RMF 1W 15K 5% METAL	1	R265
RE-233002-GP	4719-333J-2-X	RMF 2W 33K 5% METAL	2	R2, R5
QD-000202-GP	4804-0040-1	DIODE IN4004 AL	5	D1, D11, D13, D217, D218
QD-000203-GP	4838-15V6-2	DIOD ZNR 15V 1W SILICON EPIT	2	D8, D15
QD-000206-GP	4804-9340-2	DIOD RECT FAST, IN4934 AT	D208, D209	
QD-000207-GP	4860-5020-5	XISTOR NPN 250V 0.5A MJE15032	1	Q205
QD-000208-GP	4860-5060-5	TR 2SA1943 T0-3P (L)	3	Q203, Q207, Q209, Q211
QD-000209-GP	4860-5050-5	TR 2SC5200 T0-3P (L)	3	Q204, Q208, Q210, Q212
QD-000210-GP	4860-5030-5	XISTOR PNP 250V MJE15033	1	Q206

**RMX2450 Channel 2 module (continued)**

QSC part #	Revised QSC #	Description	Qty.	Notes or Component Reference
*QD-000211-GP	*4860-8890-0	TR MPS A06VCE 80V NS	1	Q5 (December 2001 and earlier)
*QD-000212-GP	*4837-5B10-2	DIODE ZENER 1/2W 5.5-5.8V	2	D207, D210 (December 2003 and earlier)
QD-000215-GP	4840-2190-0	DIODE MUR1520 15A 200V	2	D275, D276
QD-000218-GP	4837-3B20-2	DIOD ZNR 3.8-4.0V 1/2 HZ SER	1	D270
QD-000219-GP	4838-10V6-2	DIODE ZENER 1.3W 10V TEMIC	1	D274
QD-000220-GP	4838-12V6-2	DIODE ZENER 1W 12V AT TEMIC	1	D278
*QD-000221-GP	8910-0482-0	SRV-TRIAC 600V 40A MAC224 A8	1	Q213 (replaced by SG-000522-00 kit)
*QD-000269-GP	*	DIODE ZENER 5.1V 5% .25W DO-35	2	D207, D210 (January 2004 and later)
QD-000347-GP	490F-Z440-5	FETN,60V,50A,150W,, ,	2	Q270, Q274
QD-000350-10	4860-5250-5	TR 2N5064 SCR	2	D219, D220
XF-000190-GP	1804-1040-0	SPRING COIL 2UH (14GA WIRE)	1	L200

**Channel 2 SMT Parts**

CA-047005-GP	150F-470J-J-BD	CC 50V 47PF 5% 0805	3	C270, C276, C277
CA-110004-GP	150F-101K-J-BD	CC 50V 100P 10% 0805	1	C9
CA-222007-GP	150F-222K-6-CF	CC 50V 2200pF 10% 1206 1	1	C215
CA-310009-GP	150F-103M-J-BD	CC 50V 0.01uF 20% 0805 1	1	C281
CA-410014-GP	150F-104M-J-BD	0.1UF 10% 50V CER X7R 0805	1	C11
CA-410016-GP	150F-104M-6-CF	CC 50V 0.1uF 20% 1206 1.	1	C278
IC-000214-GP	3130-9240-0	LM311M VOLTAGE	2	U270, U271
QD-000201-GP	4804-1480-3	DIODE LL4148 SM	1	D14 (December 2001 and earlier)
QD-000201-GP	4804-1480-3	DIODE LL4148 SM	18	D2-D7, D9, D204, D211-D216, D271, D273, D277
QD-000201-GP	4804-1480-3	DIODE LL4148 SM	2	D16, D17 (January 2002 and later)
QD-000204-GP	4860-0640-3	XISTOR NPN 60V 200MA 3904 SOT-23	6	Q8, Q9, Q201, Q202, Q271, Q273
QD-000205-GP	4853-9060-3	XISTOR PNP 40V 0.2A TR3906 SOT-23	1	Q4 (December 2001 and earlier)
QD-000205-GP	4853-9060-3	XISTOR PNP 40V 0.2A TR3906 SOT-23	4	Q6, Q7, Q272, Q275
QD-000205-GP	4853-9060-3	XISTOR PNP 40V 0.2A TR3906 SOT-23	1	Q15 (January 2002 and later)
QD-000213-GP	4860-5110-3	TR KST42	1	Q1
RE-004702-GP	4720-470J-J	RMG 1/10W 47 OHM 5% 0805	3	R25, R270, R289
RE-007506-GP	4720-750J-J	RMG 1/10W 75 OHM 5% 0805	1	R224
RE-082003-GP	4721-821J-6	RMG 1/8W 820 OHM 5% 1206	2	R230, R232
RE-115004-GP	4720-152J-J	RMG 1/10W 1.5K 5% 0805	1	R229
RE-120004-GP	4720-202J-J	RMG 1/10W 2K 1% 0805	3	R8, R290, R295
RE-122007-GP	4720-222J-J	RMG 1/10W 2.2K 5% 0805	1	R291
RE-130103-GP	4720-3011-J	RMG 1/10W 3.01K 1% 0805	1	R275
RE-147001-GP	4720-472J-J	RMG 1/10W 4.7K 5% 0805	4	R274, R279, R287, R293
RE-159003-GP	4720-592A-J	5.9K 1% 1/10W THK FLM 0805	2	R271, R284
RE-168002-GP	4721-682J-6	RCF 1/8W 6.8K 5% ATS	1	R19
RE-210006-GP	4720-103J-J	RMG 1/10W 10K 5% 0805	1	R228
RE-212001-GP	4720-123J-J	RMG 1/10W 12K 5% 0805	1	R276
RE-247004-GP	4721-473J-6	RMG 1/8W 47K 5% 1206	1	R225
RE-247005-GP	4720-473J-J	RMG 1/10W 47K 5% 0805	1	R283
RE-315003-GP	4721-154J-6	RMG 1/8W 150K 5% 1206	5	R10, R273, R278, R286, R292
RE-322001-GP	4721-224J-6	RMG 1/8W 220K 5% 1206	2	R18, R26
RE-330001-GP	4721-334J-6	RMG 1/8W 330K 5% 1206	1	R27
RE-346401-GP	4721-4643-6	464K 1% 1/8W THK FLM 1206	1	R15
RE-347003-GP	4720-474J-J	RMG 1/10W 470K 5% 0805	2	R272, R285
RE-410002-GP	4721-105J-6	RMG 1/8W 1M 5% 1206	2	R3, R6
	4721-101J-6	RMG 1/8W 100R 5% 1206	1	R30

**WP-002455-00 Input Board Assembly (was PCB-QZ030C-INP)**

CA-147006-GP	150F-471J-5-0F	470PF 5% 50V CER NPO	4	C1, C2, C3, C4
CO-000204-GP	2113-1337-1	CONN XLR F VERT PLASTIC	2	J101, J201
CO-000235-GP	2113-1652-0	PHONE JACK 06.4	2	J102, J202
SW-000089-GP	5200-4713-0	10 POLE DIP SWITCH	1	SW1
WC-000194-GP	7010-9860-0	RIBBON CABLE 26 PIN IEC	1	J1

**WP-002452-00 Output Board Assembly (was PCB-QZ030C-OUT)**

CO-000236-GP	2113-1336-1	SPEAKON NEUTRIK 4 WIRE	2	J100, J200
PA-000043-00	2113-1338-0	PLATE ASSY,PLX/RMX,OUTPUT,,	1	J103
PL-000055-00	4154-2111-0	OUTPUT POST PLUG FOR CE (RED)	2	For European models only
PL-000056-00	4154-2121-0	OUTPUT POST PLUG FOR CE (BLACK)	2	For European models only

THIS DOCUMENT CONTAINS PROPRIETARY INFORMATION WHICH IS THE PROPERTY OF QSC AUDIO PRODUCTS. THAT MAY NOT BE DISCLOSED, REPRODUCED OR USED WITHOUT EXPRESS WRITTEN CONSENT FROM QSC AUDIO PRODUCTS.

# 7. Schematics and diagrams

REVISIONS				
REV	DESCRIPTION	EFF DATE	CHK	APPROVED DATE
A	XX			

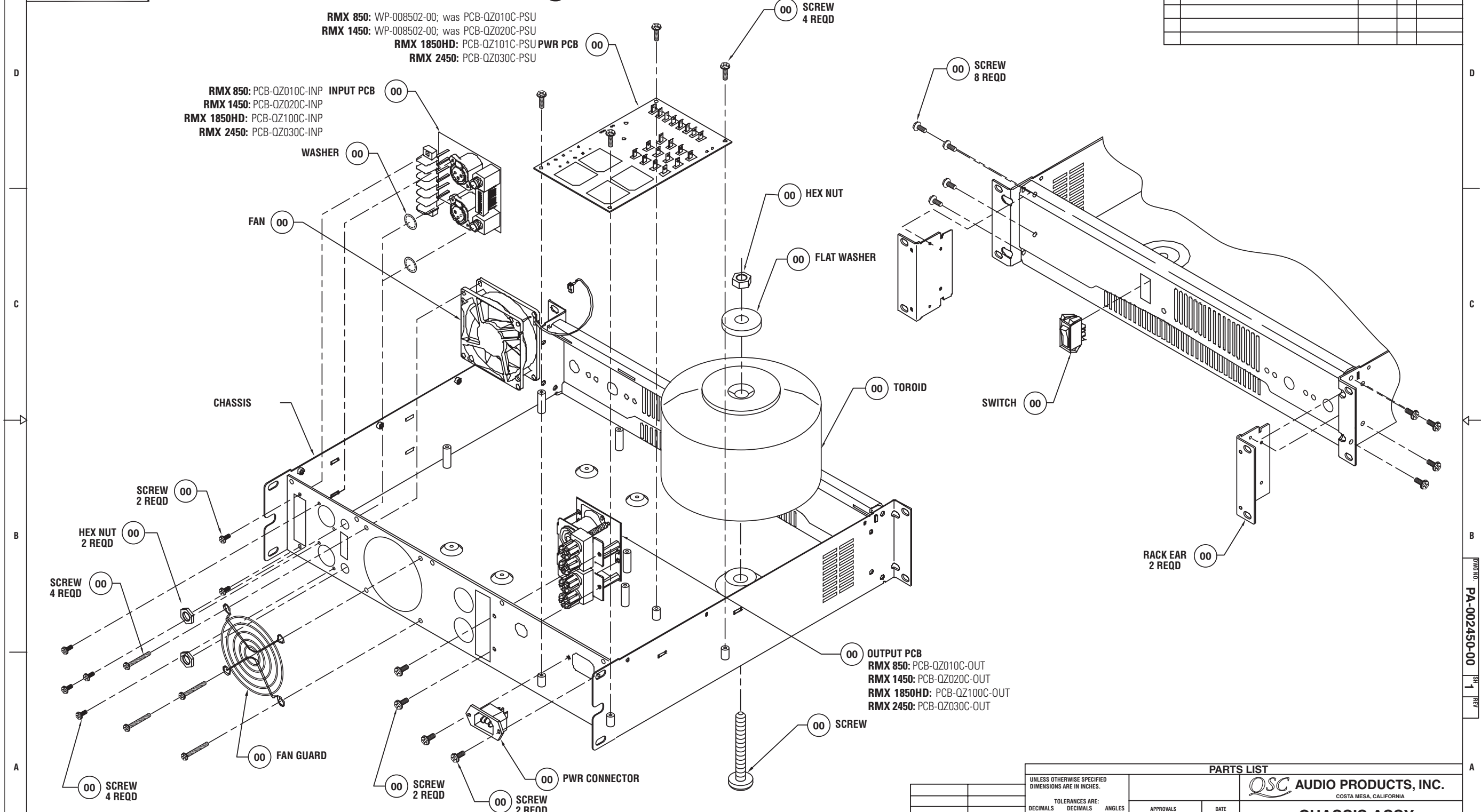

THIS DRAWING USED IN CONJUNCTION WITH SCHEMATIC DWGS MAIN PCB SH-002451, INPUT PCB XO, WIRING DIAGRAM SH-002450-00 AND FINAL ASSY PF-002450-00.  
 NOTES: UNLESS OTHERWISE SPECIFIED

**7.1 RMX Assembly/Disassembly Diagram 1 of 2**  
 (All models)

APPLICATION		PARTS LIST		QSC AUDIO PRODUCTS, INC. COSTA MESA, CALIFORNIA	
		UNLESS OTHERWISE SPECIFIED DIMENSIONS ARE IN INCHES.	APPROVALS	DATE	CHASSIS ASSY RMX 2450
		TOLERANCES ARE: DECIMALS DECIMALS ANGLES xx ± .02 xxx ± .010 ±1/2 DEBURR EDGES .XXX R MAX	MILA P.	12-07-2000	
		MATERIAL	CHECKED		D
		SEE TABULATION BLOCK	ISSUED		
X	RMX 2450	FINISH			DWG NO. PA-002450-00
	NEXT ASSY USED ON	DO NOT SCALE DRAWING			REV
					SCALE 1/2 SHEET 1 OF 2

DWG NO. PA-002450-00

THIS DOCUMENT CONTAINS PROPRIETARY INFORMATION WHICH IS THE PROPERTY OF QSC AUDIO PRODUCTS. THAT MAY NOT BE DISCLOSED, REPRODUCED OR USED WITHOUT EXPRESS WRITTEN CONSENT FROM QSC AUDIO PRODUCTS.

**CHANNEL MODULES**

- RMX 850:** WP-008504-00; was PCB-QZ010C-PWR2 (right or Channel 2)
- RMX 1450:** WP-014503-00; was PCB-QZ020C-PWR2 (right or Channel 2)
- RMX 1850HD:** WP-018503-00; was PCB-QZ100C-PWR2 (right or Channel 1)
- RMX 2450:** WP-002453-00; was PCB-QZ030C-PWR2 (right or Channel 1)

**CHANNEL MODULES**

- RMX 850:** WP-008503-00; was PCB-QZ010C-PWR1 (left or Channel 1)
- RMX 1450:** WP-014502-00; was PCB-QZ020C-PWR1 (left or Channel 1)
- RMX 1850HD:** WP-018504-00; was PCB-QZ100C-PWR1 (left or Channel 2)
- RMX 2450:** WP-002454-00; was PCB-QZ030C-PWR1 (left or Channel 2)

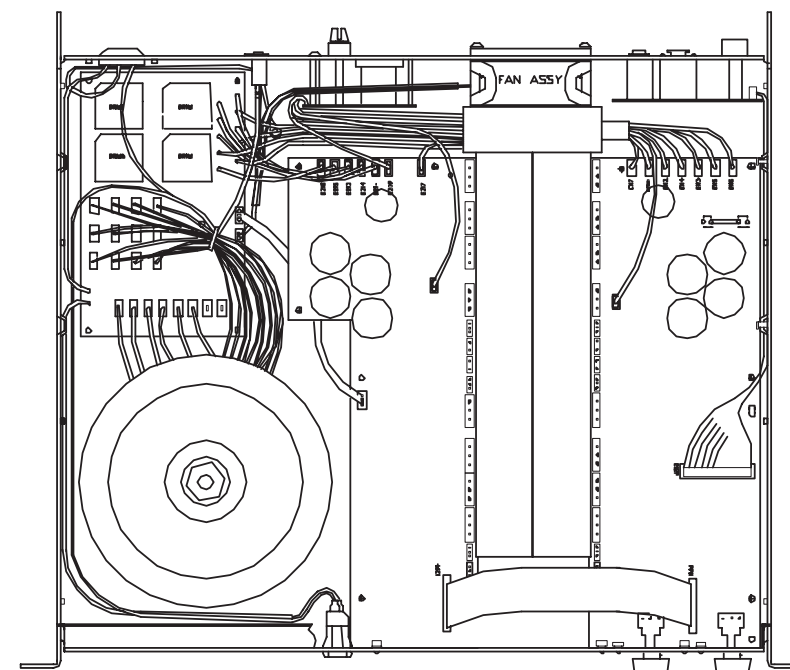
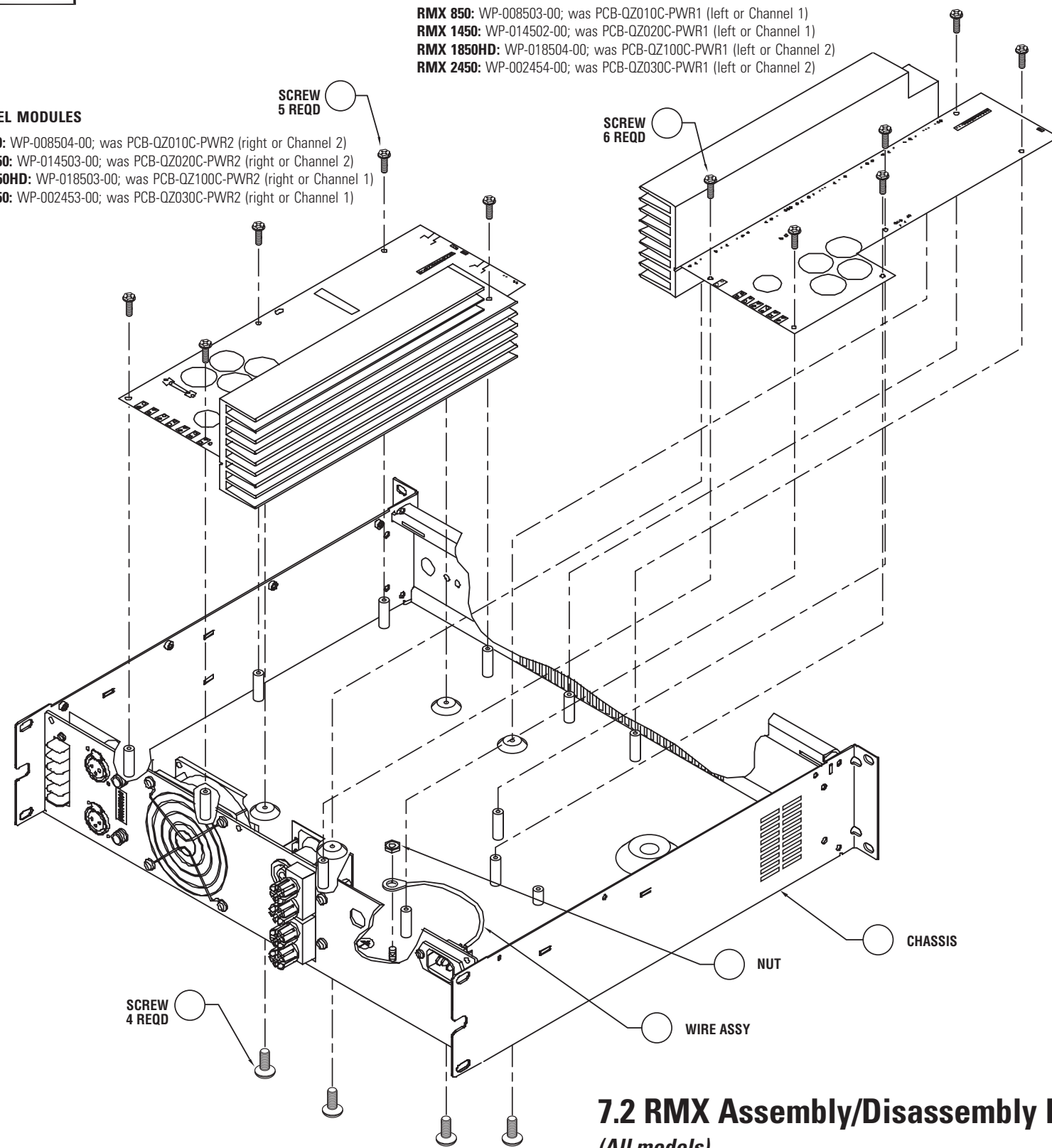

**7.2 RMX Assembly/Disassembly Diagram 2 of 2**  
(All models)

<b>D</b>	DWG NO.	PA-002450-00	REV
	SCALE	1/2	SHEET 2 OF 2

DWG NO. PA-002450-00 REV 2

THIS DOCUMENT CONTAINS PROPRIETARY INFORMATION WHICH IS THE PROPERTY OF QSC AUDIO PRODUCTS. THAT MAY NOT BE DISCLOSED, REPRODUCED OR USED WITHOUT EXPRESS WRITTEN CONSENT FROM QSC AUDIO PRODUCTS.

REVISION				
REV	DESCRIPTION	EFF DATE	CHK	APPROVED / DATE
1	PROTOTYPE RELEASE	3-01-00		
2				
3	CLEAN UP BY AA	3-10-00		

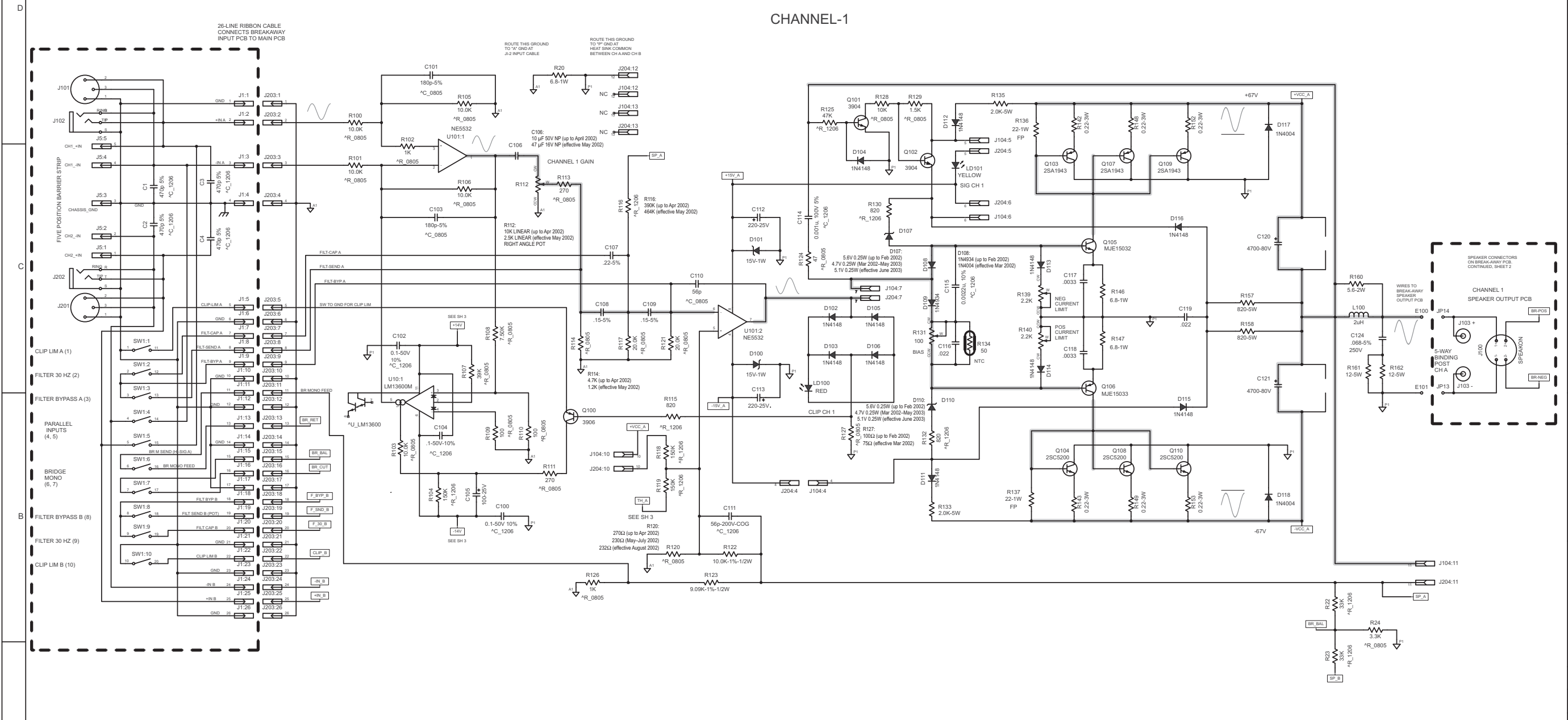

Gray shading indicates signal path

- 5. J104, J204 ARE CONNECTED PIN TO PIN BY 13-LINE RIBBON CABLE.
- 4. PART NUMBERING SCHEME  
PARTS IN COMMON TO BOTH CH: 1-99. CH 1 PARTS 101-199. CH 2 PARTS 201-299.
- 3. COMPONENTS MARKED WITH  $\Delta$  ARE SAFETY CRITICAL PARTS.
- 2. COMPONENTS WITH VALUE PREFIXED WITH A "\*" REPRESENT SMT COMPONENTS.
- 1. THIS DRAWING USED IN CONJUNCTION WITH ASSEMBLY WP-000851-00

NOTES: UNLESS OTHERWISE SPECIFIED

## 7.3 RMX850 Schematic Diagram 1 of 3

### Channel 1

QTY	ITEM NO.	PART NO.	DESCRIPTION	VENDOR
PARTS LIST				
UNLESS OTHERWISE SPECIFIED DIMENSIONS ARE IN INCHES. DIMENSIONS PER ANSI Y14.5-1982 TOLERANCES ARE: DECIMALS    DECIMALS    ANGLES xx .x    .xxx    °			CONTRACT NO.	
DEBURR EDGES XXX R MAX			APPROVALS    DATE	
MATERIAL			DRAWN    PAT QUILTER    2-25-00	
FINISH			CHECKED	
ISSUED			SIZE    FSCM NO.    DWG NO.	
NEXT ASSY    USED ON			D    SH-000850-00    3	
APPLICATION			CAD SEED FILE NO.    PLOT DATE: Thu Sep 07, 2000	
DO NOT SCALE DRAWING			SCALE    NONE    CAD FILE NO.    RMX0850-3.sch    SHEET    1 OF 3	
			PFRMXGSCRMX850    1    PLOT DATE: Thu Sep 07, 2000	

SH-000850-00 1

THIS DOCUMENT CONTAINS PROPRIETARY INFORMATION WHICH IS THE PROPERTY OF QSC AUDIO PRODUCTS. THAT MAY NOT BE DISCLOSED, REPRODUCED OR USED WITHOUT EXPRESS WRITTEN CONSENT FROM QSC AUDIO PRODUCTS.

CHANNEL-2

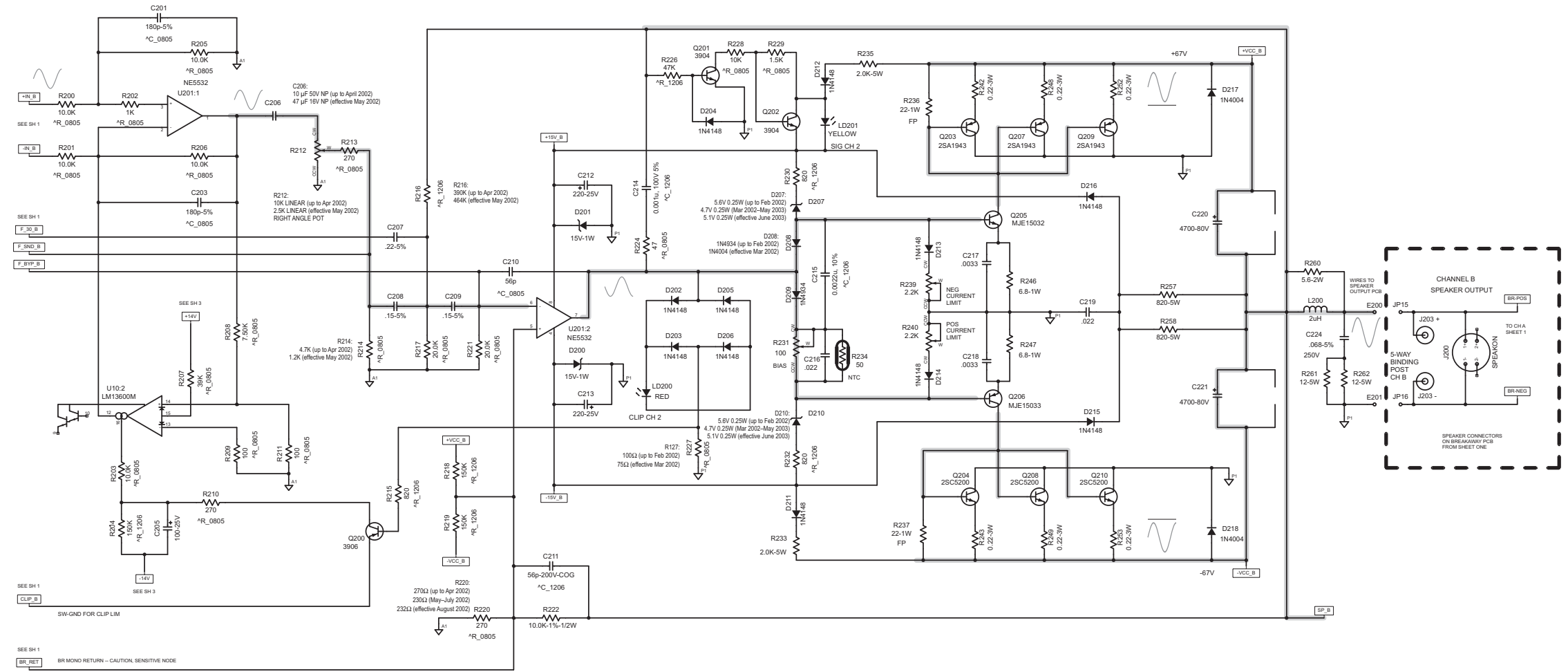

Gray shading indicates signal path

7.4 RMX850 Schematic Diagram 2 of 3  
Channel 2

NOTES: UNLESS OTHERWISE SPECIFIED

SIZE	FSCM NO.	DWG NO.	REV
D		SH-000850-00	3
SCALE	NONE	CAD FILE NO.	RMX850-3.sch
		SHEET	2 OF 3
		PLOT DATE:	Thu Sep 07, 2000

SH-000850-00  
3 2 1

THIS DOCUMENT CONTAINS PROPRIETARY INFORMATION WHICH IS THE PROPERTY OF GSC AUDIO PRODUCTS, THAT MAY NOT BE DISCLOSED, REPRODUCED OR USED WITHOUT EXPRESS WRITTEN CONSENT FROM GSC AUDIO PRODUCTS.

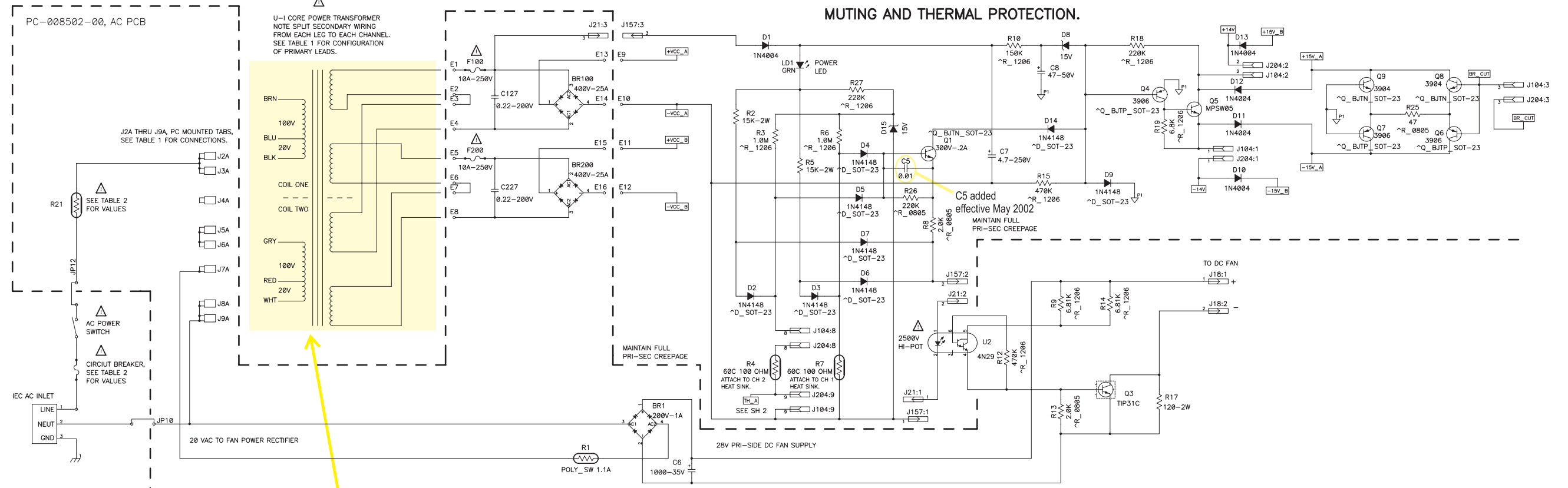

Until February 2007.  
See p. 48 for current transformer configuration.

POWER TRANSFORMER PRIMARY LEAD COLOR	AC LINE VOLTAGE			TAB
	100V	120V	240V	
BRN	BRN	BRN	BRN	J2A
GRY	GRY	-	BLU	J3A
BLK	BLU	BLU	BLU	J4A
-	-	BLK	BLK	J5A
-	-	GRY	GRY	J6A
WHT	RED	RED	RED	J7A
BLU	BLK	-	BLK	J8A
RED	WHT	WHT	WHT	J9A

CIRCUIT BREAKER	AC LINE VOLTAGE		
	100V	120V	240V
R21	1 OHM 30A	1 OHM 30A	1 OHM 30A

### 7.5 RMX850 Schematic Diagram 3 of 3

Power Supply

NOTES: UNLESS OTHERWISE SPECIFIED

SIZE	FSCM NO.	DWG NO.	REV
D		SH-008501-00	F
SCALE	CAD FILE NO.	SHEET	REV
NONE	SH8501RF.SCH	4 OF 4	
PLOT DATE:		1	
Wed Nov 23, 2005			

THIS DOCUMENT CONTAINS PROPRIETARY INFORMATION WHICH IS THE PROPERTY OF QSC AUDIO PRODUCTS. THAT MAY NOT BE DISCLOSED, REPRODUCED OR USED WITHOUT EXPRESS WRITTEN CONSENT FROM QSC AUDIO PRODUCTS.

REVISION				
REV	DESCRIPTION	EFF. DATE	CHK	APPROVED/DATE
1	PROTOTYPE RELEASE	3-01-00		
2	CLEAN UP BY PHQ	3-02-00		
3				
4	CLEAN UP BY AA	3-10-00		

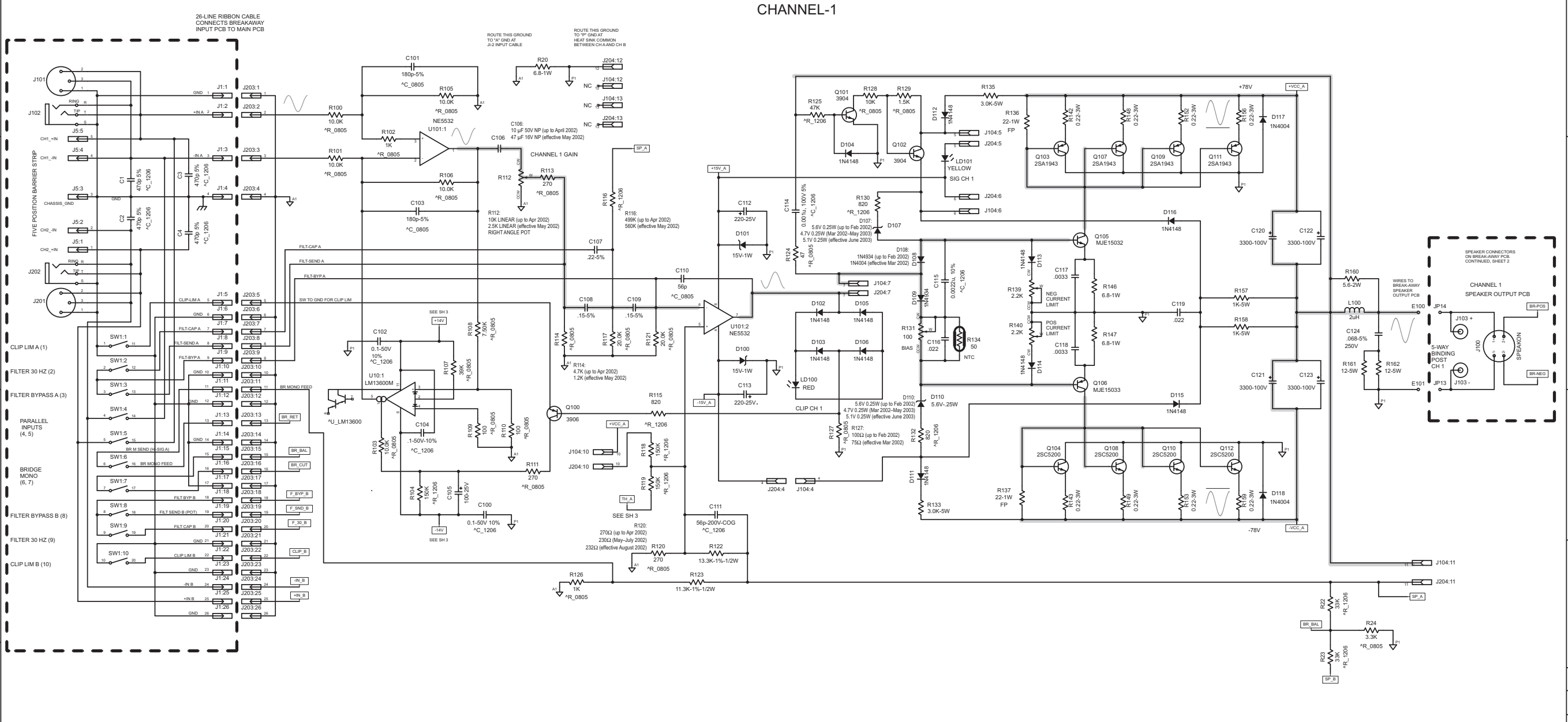

- Gray shading indicates signal path
- J104, J204 ARE CONNECTED PIN TO PIN BY 13-LINE RIBBON CABLE.
  - PART NUMBERING SCHEME  
PARTS IN COMMON TO BOTH CH: 1-99. CH 1 PARTS 101-199, CH 2 PARTS 201-299.
  - COMPONENTS MARKED WITH  $\Delta$  ARE SAFETY CRITICAL PARTS.
  - COMPONENTS WITH VALUE PREFIXED WITH A "\*" REPRESENT SMT COMPONENTS.
  - THIS DRAWING USED IN CONJUNCTION WITH ASSEMBLY WP-001451-00

## 7.6 RMX1450 Schematic Diagram 1 of 3

### Channel 1

NOTES: UNLESS OTHERWISE SPECIFIED

QTY	ITEM NO.	PART NO.	DESCRIPTION	VENDOR
PARTS LIST				
UNLESS OTHERWISE SPECIFIED: DIMENSIONS ARE IN INCHES. TOLERANCES ARE: DECIMALS    DECIMALS    ANGLES XX .    XXX .    °			CONTRACT NO.	
DRAWN: PAT QUILTER			DATE: 2-25-00	
CHECKED:			ISSUED:	
CAD SEED FILE NO.			PLOT DATE: Thu Sep 07, 2000	
SCALE: NONE			DWG NO.: RMX1450-4.sch	
APPLICATION: DO NOT SCALE DRAWING			SHEET 1 OF 3	

**QSC** AUDIO PRODUCTS, INC.  
COSTA MESA, CALIFORNIA

**SCHEMATIC DIAGRAM**  
RMX 1450

SIZE: D    FSCM NO.:    DWG NO.: RMX1450-4.sch    REV: 4

PLOT DATE: Thu Sep 07, 2000

SH-001451-00



THIS DOCUMENT CONTAINS PROPRIETARY INFORMATION WHICH IS THE PROPERTY OF CSC AUDIO PRODUCTS. THAT MAY NOT BE DISCLOSED, REPRODUCED OR USED WITHOUT EXPRESS WRITTEN CONSENT FROM CSC AUDIO PRODUCTS.

### CHANNEL-2

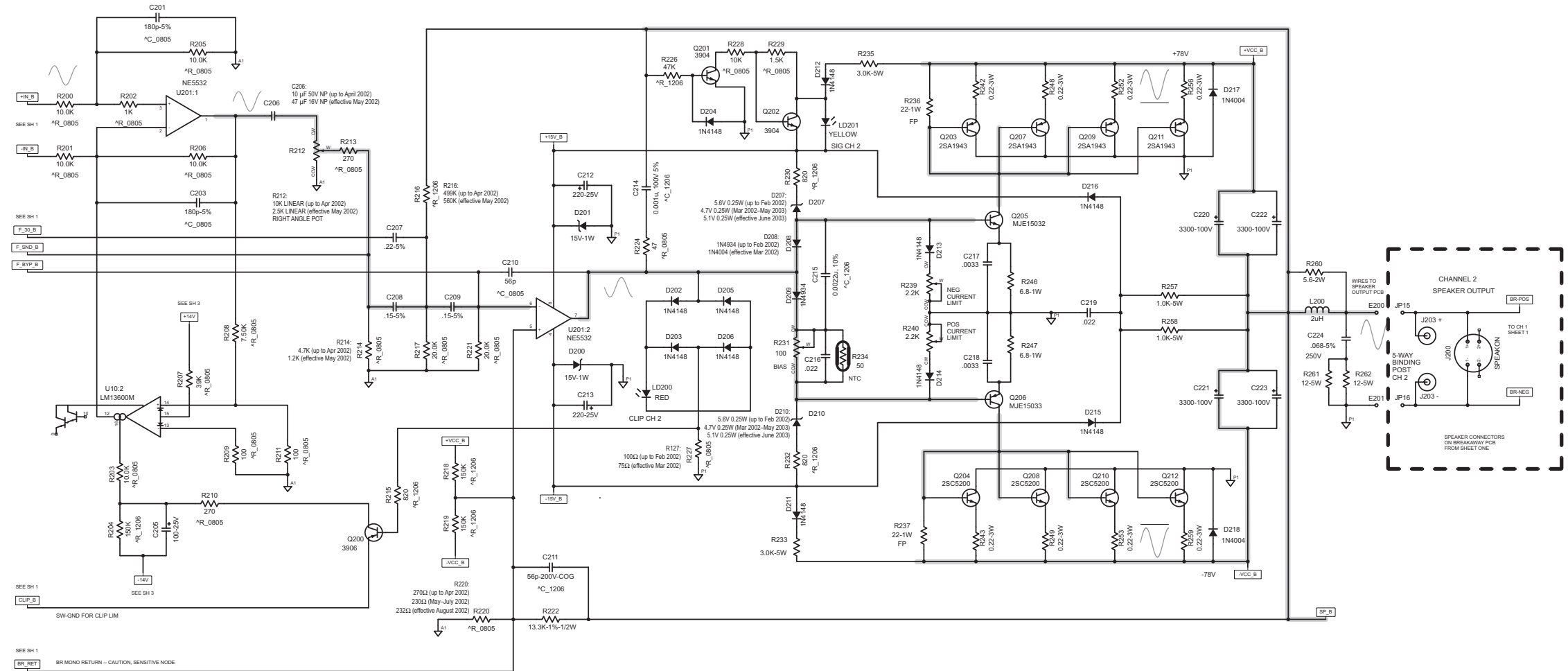

Gray shading indicates signal path

## 7.7 RMX1450 Schematic Diagram 2 of 3

### Channel 2

NOTES: UNLESS OTHERWISE SPECIFIED

SIZE	FSCM NO.	DWG NO.	REV
D		SH-001451-00	4
SCALE	NONE	CAD FILE NO. RMX1450-4.sch	SHEET 2 OF 3

PLOT DATE: Thu Sep 07, 2000

THIS DOCUMENT CONTAINS PROPRIETARY INFORMATION WHICH IS THE PROPERTY OF QSC AUDIO PRODUCTS. THAT MAY NOT BE DISCLOSED, REPRODUCED OR USED WITHOUT EXPRESS WRITTEN CONSENT FROM QSC AUDIO PRODUCTS.

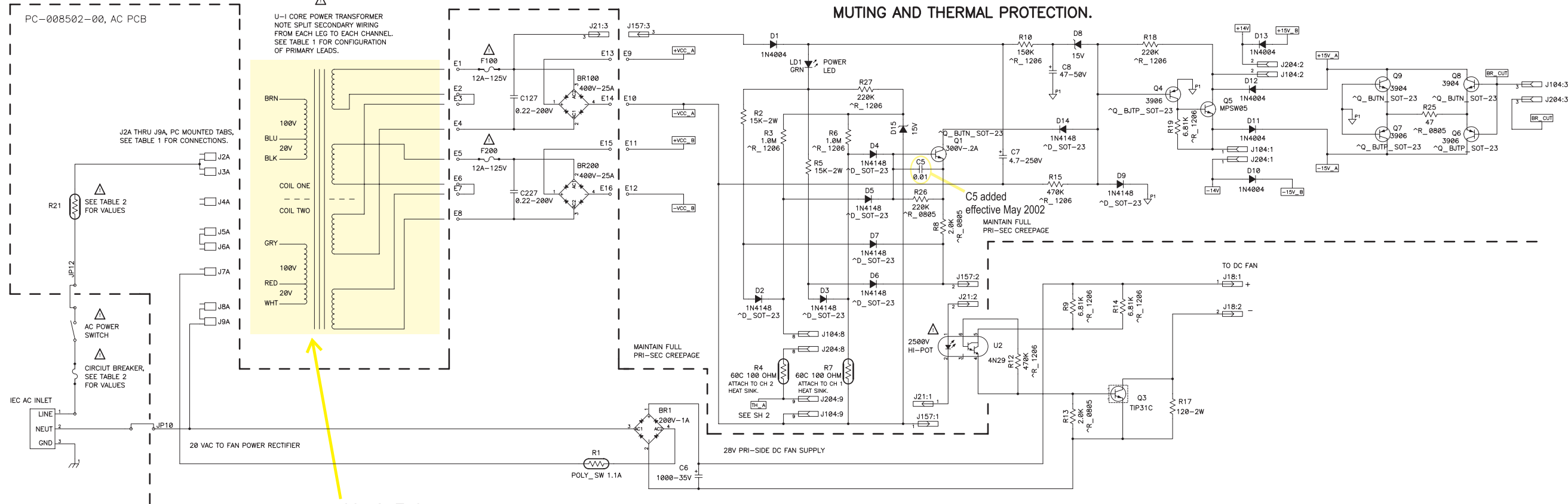

Until February 2007.  
See p. 48 for current transformer configuration.

POWER TRANSFORMER PRIMARY LEAD COLOR	AC LINE VOLTAGE			TAB
	100V	120V	240V	
BRN	BRN	BRN	BRN	J2A
GRY	GRY	-	-	J3A
BLK	BLU	BLU	BLU	J4A
-	-	BLK	BLK	J5A
-	-	GRY	GRY	J6A
WHT	RED	RED	RED	J7A
BLU	BLK	-	-	J8A
RED	WHT	WHT	WHT	J9A

CIRCUIT BREAKER	AC LINE VOLTAGE		
	100V	120V	240V
R21	1 OHM 30A	1 OHM 30A	1 OHM 30A

### 7.8 RMX1450 Schematic Diagram 3 of 3 Power Supply

NOTES: UNLESS OTHERWISE SPECIFIED

SIZE: D	FSCM NO.:	DWG NO.:	REV:
SCALE: NONE	CAD FILE NO.:	SH-014501-00	F
PLOT DATE:		SHEET 4 OF 4	
Wed Nov 23, 2005		1	

F 4 SH-014501-00

THIS DOCUMENT CONTAINS PROPRIETARY INFORMATION WHICH IS THE PROPERTY OF QSC AUDIO PRODUCTS. THAT MAY NOT BE DISCLOSED, REPRODUCED OR USED WITHOUT EXPRESS WRITTEN CONSENT FROM QSC AUDIO PRODUCTS.

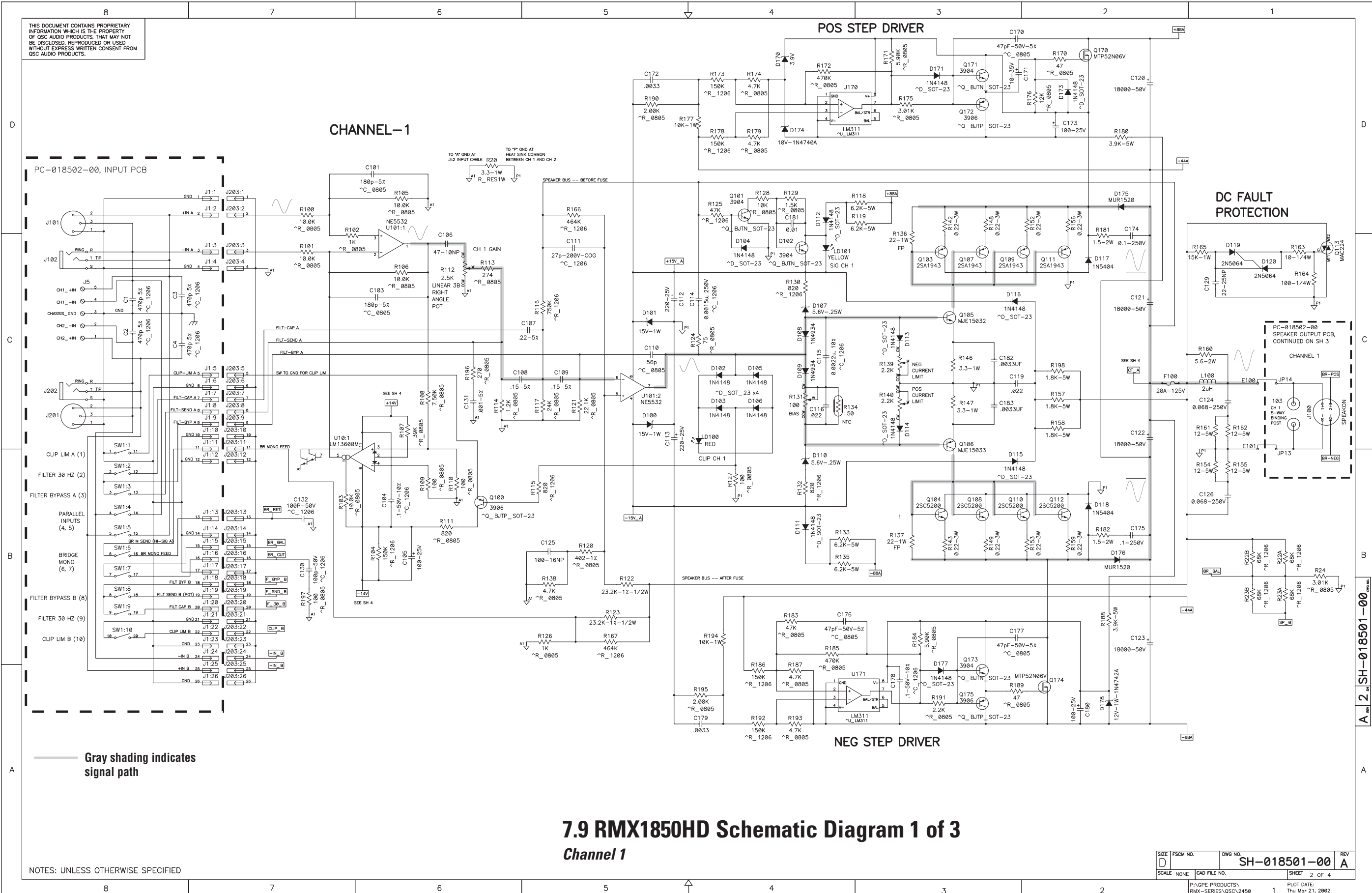

## 7.9 RMX1850HD Schematic Diagram 1 of 3

### Channel 1

SIZE	FSCM NO.	DWG NO.	REV
D		SH-018501-00	A
SCALE	NONE	CAD FILE NO.	SHEET 2 OF 4
P:\QPE PRODUCTS\RMX-SERIES\QSC\2450		PLOT DATE: Thu Mar 21, 2002	

THIS DOCUMENT CONTAINS PROPRIETARY INFORMATION WHICH IS THE PROPERTY OF QSC AUDIO PRODUCTS. THAT MAY NOT BE DISCLOSED, REPRODUCED OR USED WITHOUT EXPRESS WRITTEN CONSENT FROM QSC AUDIO PRODUCTS.

CHANNEL-2

POS STEP DRIVER

NEG STEP DRIVER

DC FAULT PROTECTION

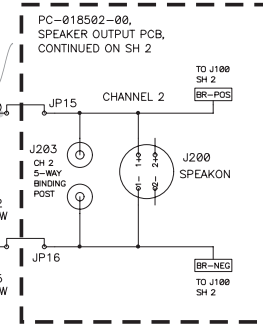

Gray shading indicates signal path

7.10 RMX1850HD Schematic Diagram 2 of 3  
Channel 2

NOTES: UNLESS OTHERWISE SPECIFIED

SIZE	FSCM NO.	DWG NO.	REV
D		SH-018501-00	A
SCALE	NONE	CAD FILE NO. SH1851RB.SCH	SHEET 3 OF 4

PLOT DATE: Thu Mar 21, 2002

THIS DOCUMENT CONTAINS PROPRIETARY INFORMATION WHICH IS THE PROPERTY OF GSC AUDIO PRODUCTS, THAT MAY NOT BE DISCLOSED, REPRODUCED OR USED WITHOUT EXPRESS WRITTEN CONSENT FROM GSC AUDIO PRODUCTS.

PC-018502-00, AC PCB

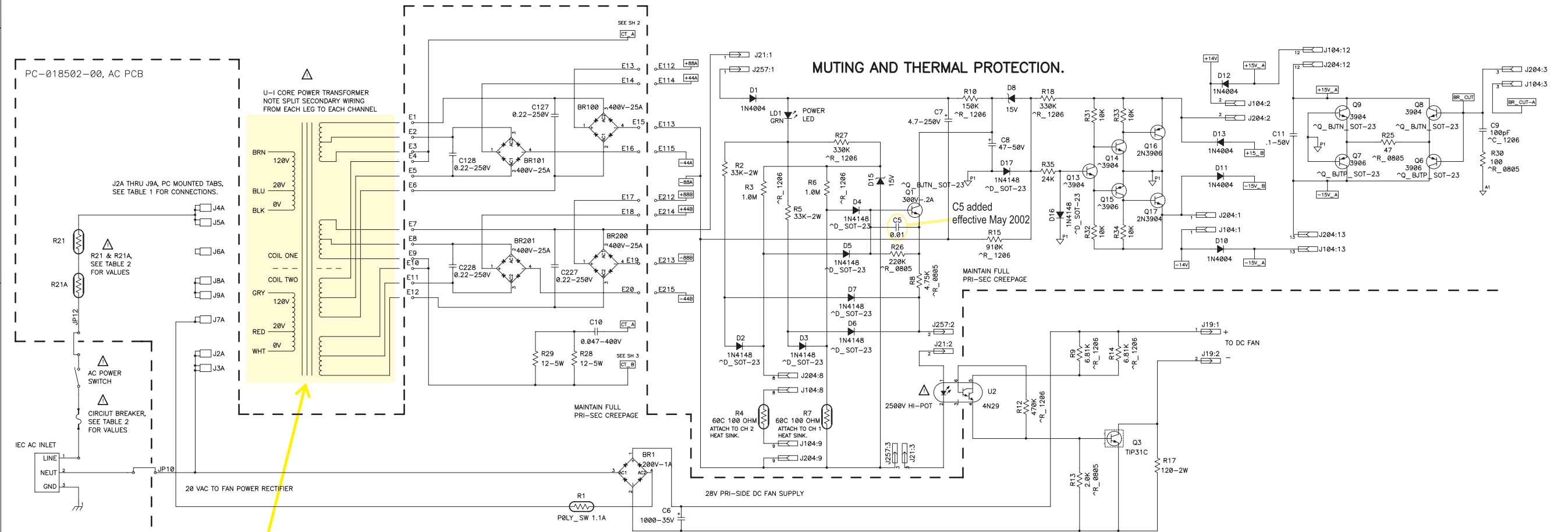

Until February 2007.  
See p. 48 for current transformer configuration.

TABLE 1

POWER TRANSFORMER PRIMARY LEAD COLOR	AC LINE VOLTAGE			TAB
	100V	120V	240V	
BRN	BRN	BRN	BRN	J4A
GRY	GRY	-	-	J5A
BLK	BLU	BLU	BLU	J6A
-	-	-	BLK	J8A
-	-	-	GRY	J9A
WHT	RED	RED	RED	J7A
BLU	BLK	-	-	J2A
RED	WHT	WHT	WHT	J3A

TABLE 2

CIRCUIT BREAKER	AC LINE VOLTAGE		
	100V	120V	240V
R21	1 OHM 30A	1 OHM 30A	4 OHM 15A
R21A	0 OHM (JUMPER)	0 OHM (JUMPER)	4 OHM 15A

### 7.11 RMX1850HD Schematic Diagram 3 of 3

#### Power Supply

NOTES: UNLESS OTHERWISE SPECIFIED

SIZE	FSCM NO.	DWG NO.	REV
D		SH-018501-00	A
SCALE	NONE	CAD FILE NO.	SH1851RB.SCH
		SHEET	4 OF 4
		PLOT DATE:	Thu Mar 21, 2002
			1

THIS DOCUMENT CONTAINS PROPRIETARY INFORMATION WHICH IS THE PROPERTY OF QSC AUDIO PRODUCTS. THAT MAY NOT BE DISCLOSED, REPRODUCED OR USED WITHOUT EXPRESS WRITTEN CONSENT FROM QSC AUDIO PRODUCTS.

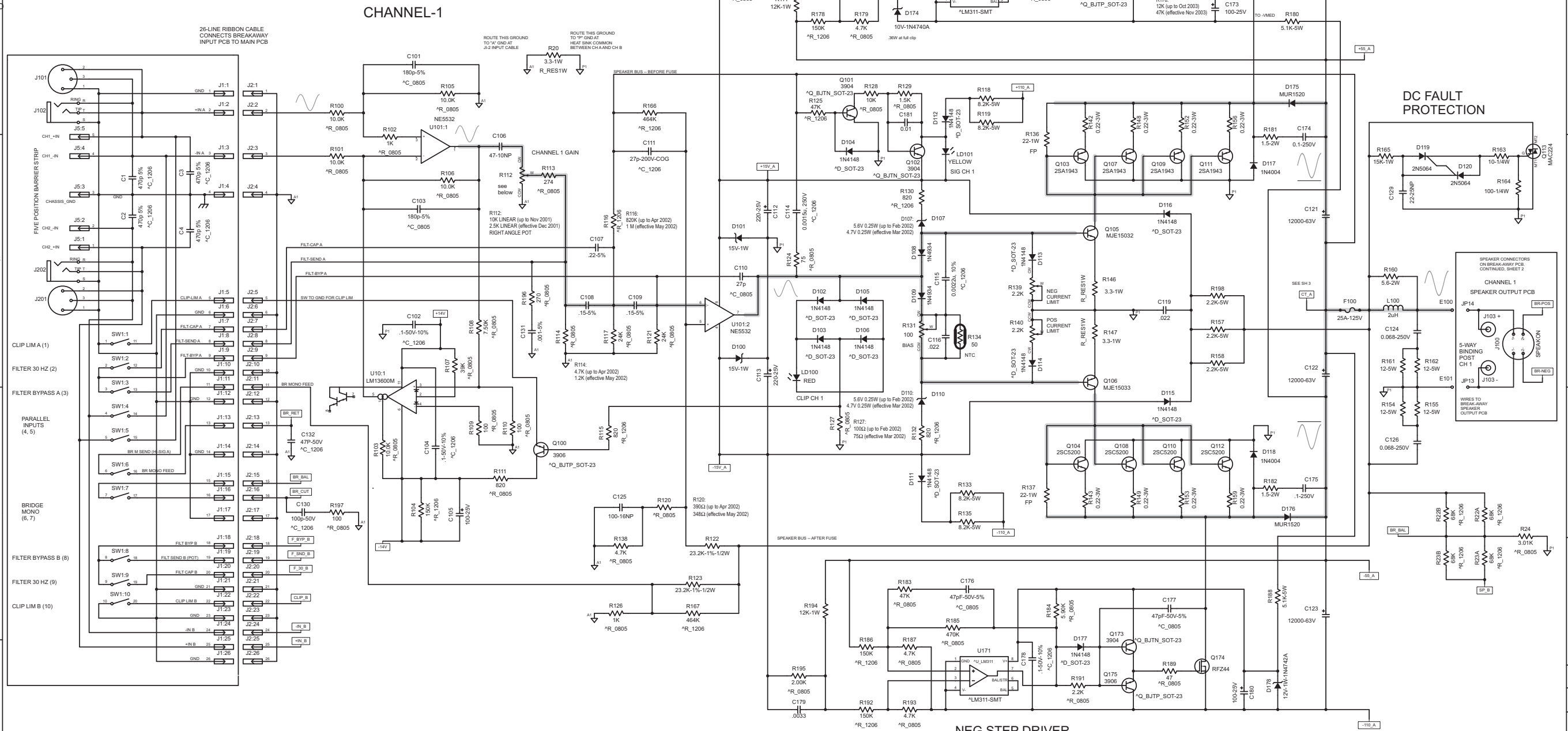

Gray shading indicates signal path

# 7.12 RMX2450 Schematic Diagram 1 of 4

## Channel 1

NOTES: UNLESS OTHERWISE SPECIFIED

SIZE	D	FSCM NO.	DWG NO.	REV
SCALE	NONE	CAD FILE NO.	SH-002451-00	4
P/PRP			1	PLT DATE:
PRODUCTS/PRMX-SERIES/QSC245			1	Thu Sep 07, 2000

SH-002451-00  
4 2

THIS DOCUMENT CONTAINS PROPRIETARY INFORMATION WHICH IS THE PROPERTY OF QSC AUDIO PRODUCTS. THAT MAY NOT BE DISCLOSED, REPRODUCED OR USED WITHOUT EXPRESS WRITTEN CONSENT FROM QSC AUDIO PRODUCTS.

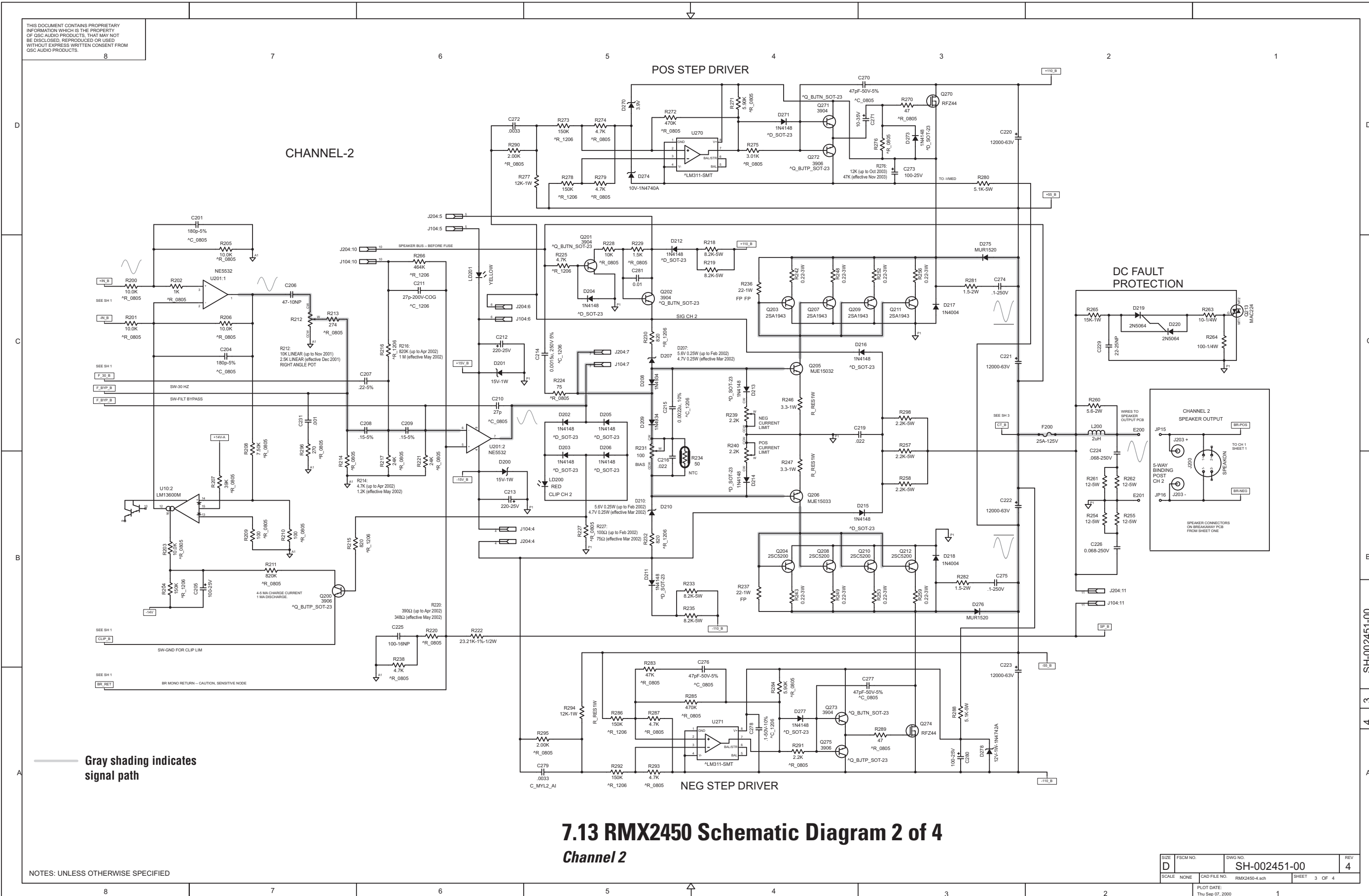

Gray shading indicates signal path

NOTES: UNLESS OTHERWISE SPECIFIED

### 7.13 RMX2450 Schematic Diagram 2 of 4 Channel 2

SIZE	FSCM NO.	DWG NO.	REV
D		SH-002451-00	4
SCALE	NONE	CAD FILE NO. RMX2450-4.sch	SHEET 3 OF 4
PLOT DATE: Thu Sep 07, 2000			1

THIS DOCUMENT CONTAINS PROPRIETARY INFORMATION WHICH IS THE PROPERTY OF QSC AUDIO PRODUCTS. THAT MAY NOT BE DISCLOSED, REPRODUCED OR USED WITHOUT EXPRESS WRITTEN CONSENT FROM QSC AUDIO PRODUCTS.

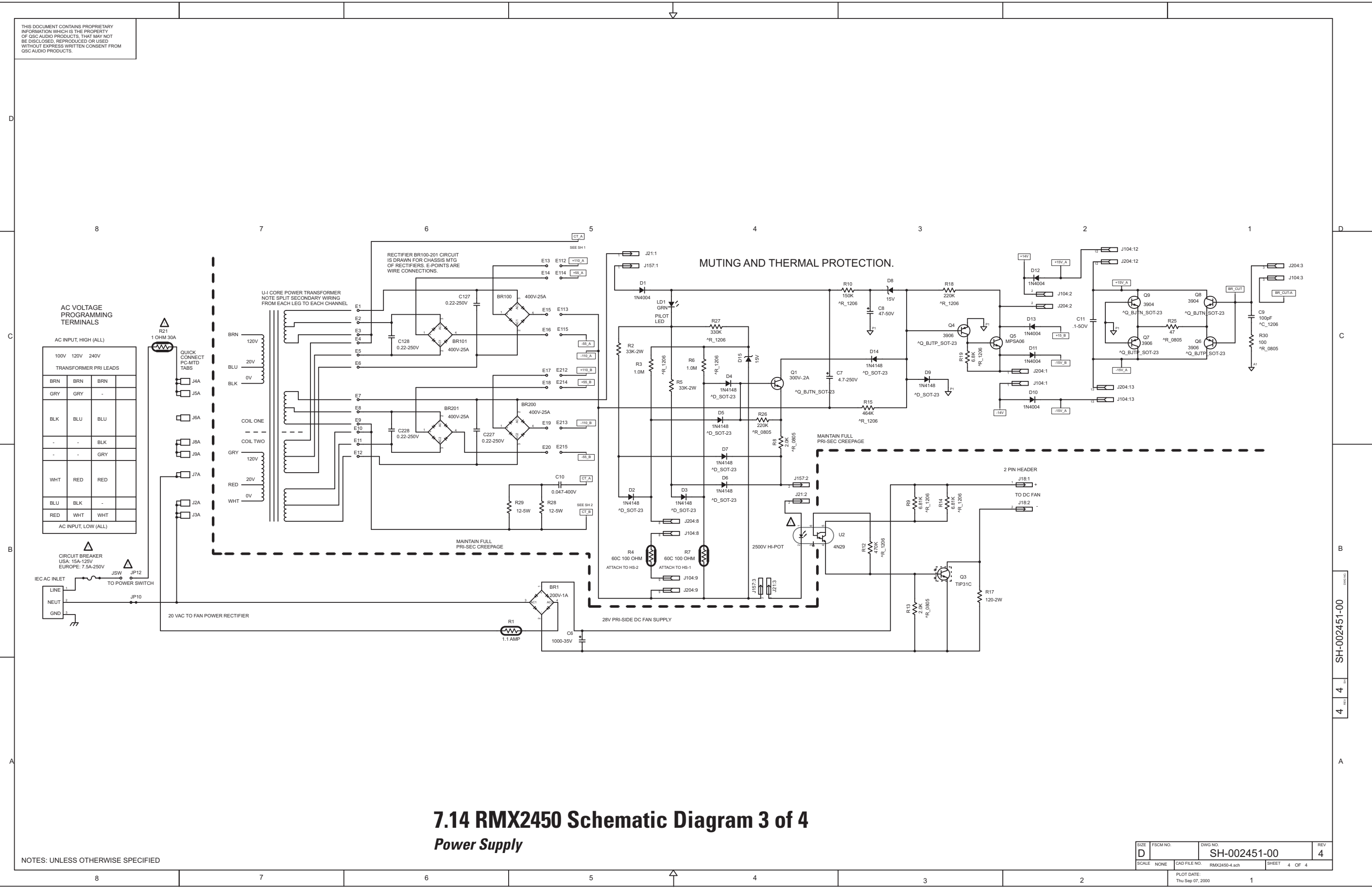

### 7.14 RMX2450 Schematic Diagram 3 of 4

#### Power Supply

NOTES: UNLESS OTHERWISE SPECIFIED

SIZE	FSCM NO.	DWG NO.	REV
D		SH-002451-00	4
SCALE	NONE	CAD FILE NO.	SHEET
		RMX2450-4.sch	4 OF 4
PLOT DATE:		1	
Thu Sep 07, 2000			

SH-002451-00 4 4



THIS DOCUMENT CONTAINS PROPRIETARY INFORMATION WHICH IS THE PROPERTY OF GSC AUDIO PRODUCTS, THAT MAY NOT BE DISCLOSED, REPRODUCED OR USED WITHOUT EXPRESS WRITTEN CONSENT FROM GSC AUDIO PRODUCTS.

PC-002452-00, AC PCB

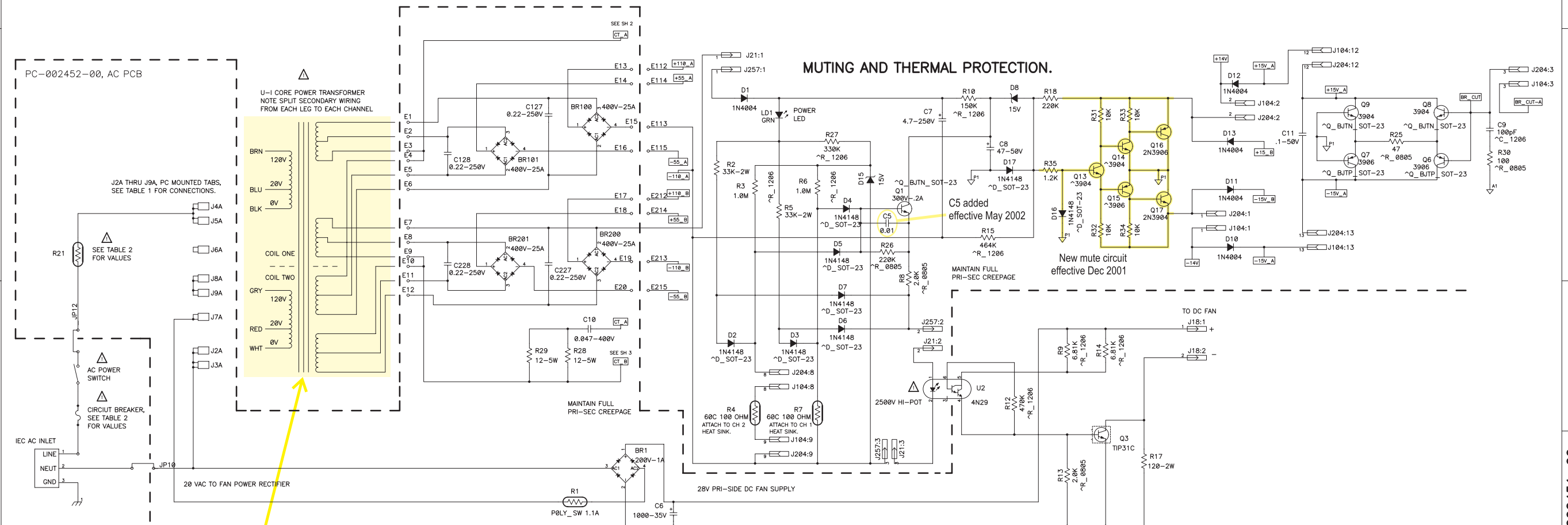

Until February 2007.  
See p. 48 for current transformer configuration.

TAB	AC LINE VOLTAGE			POWER TRANSFORMER PRIMARY LEAD COLOR
	100V	120V	240V	
J2A	BLU	BLK	--	
J3A	RED	WHT	WHT	
J4A	BRN	BRN	BRN	
J5A	GRY	GRY	--	
J6A	BLK	BLU	BLU	
J7A	WHT	RED	RED	
J8A	--	--	BLK	
J9A	--	--	GRY	

	AC LINE VOLTAGE		
	100V	120V	240V
CIRCUIT BREAKER	15A-125V	15A-125V	7.5A-250V
R21	1 OHM 30A	1 OHM 30A	1 OHM 30A

## 7.15 RMX2450 Schematic Diagram 4 of 4

### Power Supply Revision

NOTES: UNLESS OTHERWISE SPECIFIED

SIZE	FSCM NO.	DWG NO.	REV
D		SH-002451-00	F
SCALE	NONE	CAD FILE NO. SH2451F.SCH	SHEET 4 OF 4
		PLOT DATE: Tue Dec 16, 2003	1

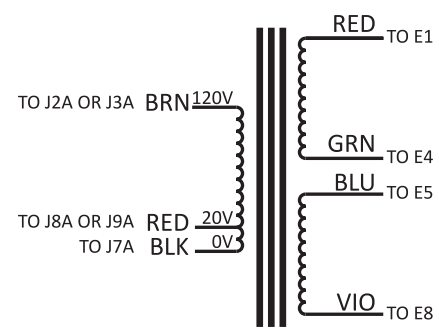

XF-000315-GP  
RMX850, 100V

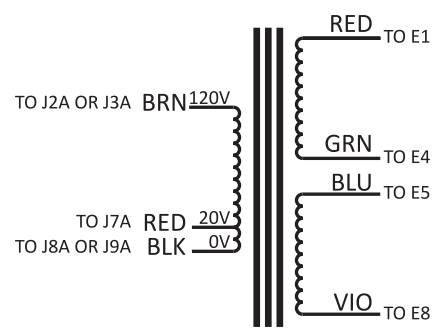

XF-000315-GP  
RMX850, 120V

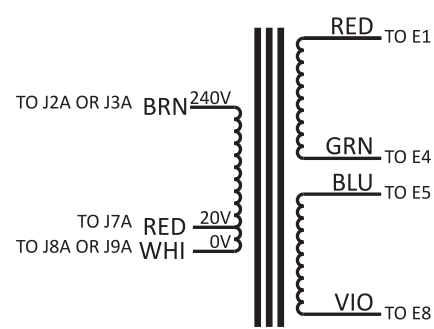

XF-000314-GP  
RMX850, 230V

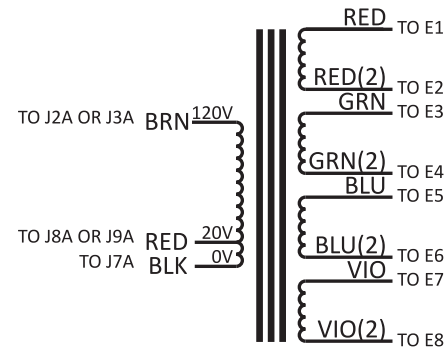

XF-000317-GP  
RMX1450, 100V

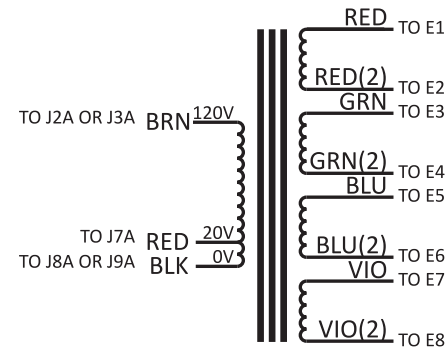

XF-000317-GP  
RMX1450, 120V

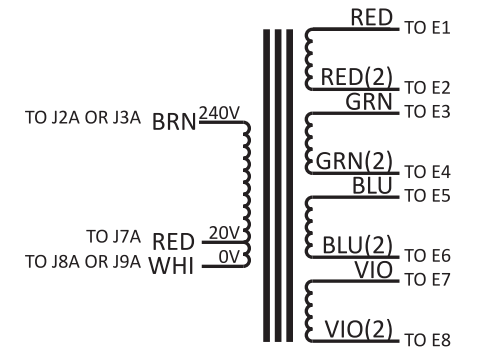

XF-000316-GP  
RMX1450, 230V

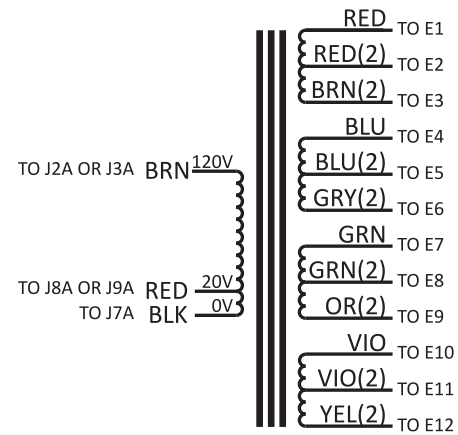

XF-000321-GP  
RMX1850HD, 100V

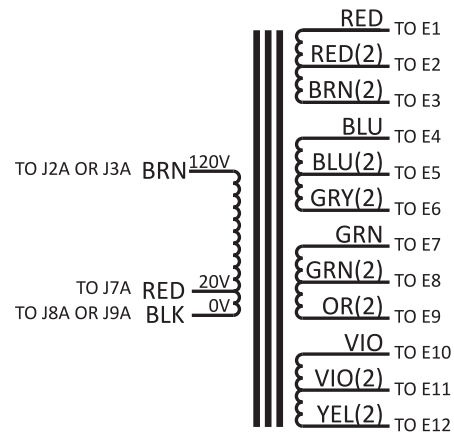

XF-000321-GP  
RMX1850HD, 120V

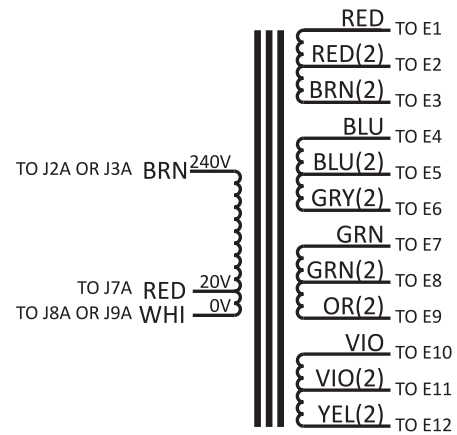

XF-000320-GP  
RMX1850HD, 230V

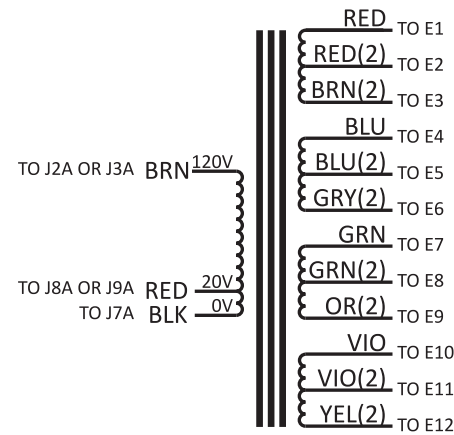

XF-000319-GP  
RMX2450, 100V

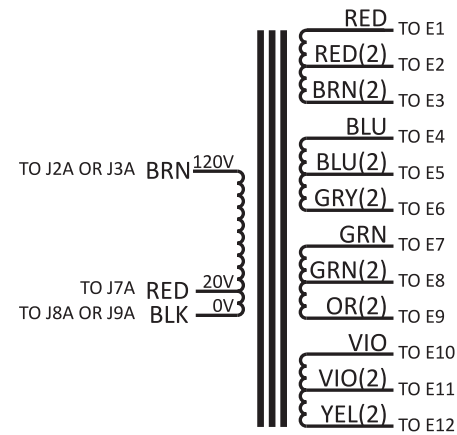

XF-000319-GP  
RMX2450, 120V

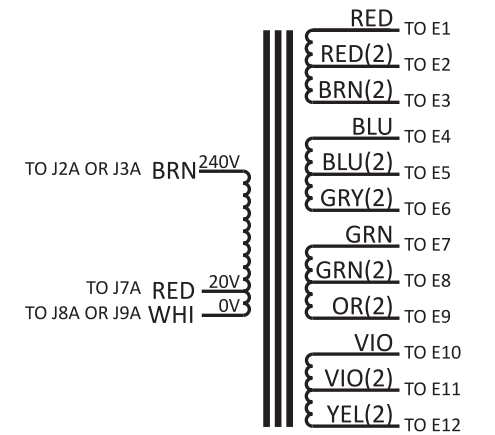

XF-000318-GP  
RMX2450, 230V

## 7.16 RMX Power Transformer Configurations

March 2007 and later

THIS DOCUMENT CONTAINS PROPRIETARY INFORMATION WHICH IS THE PROPERTY OF QSC AUDIO PRODUCTS. THAT MAY NOT BE DISCLOSED, REPRODUCED OR USED WITHOUT EXPRESS WRITTEN CONSENT FROM QSC AUDIO PRODUCTS.

REVISIONS				
REV	DESCRIPTION	EFF. DATE	CHK	APPROVED/DATE

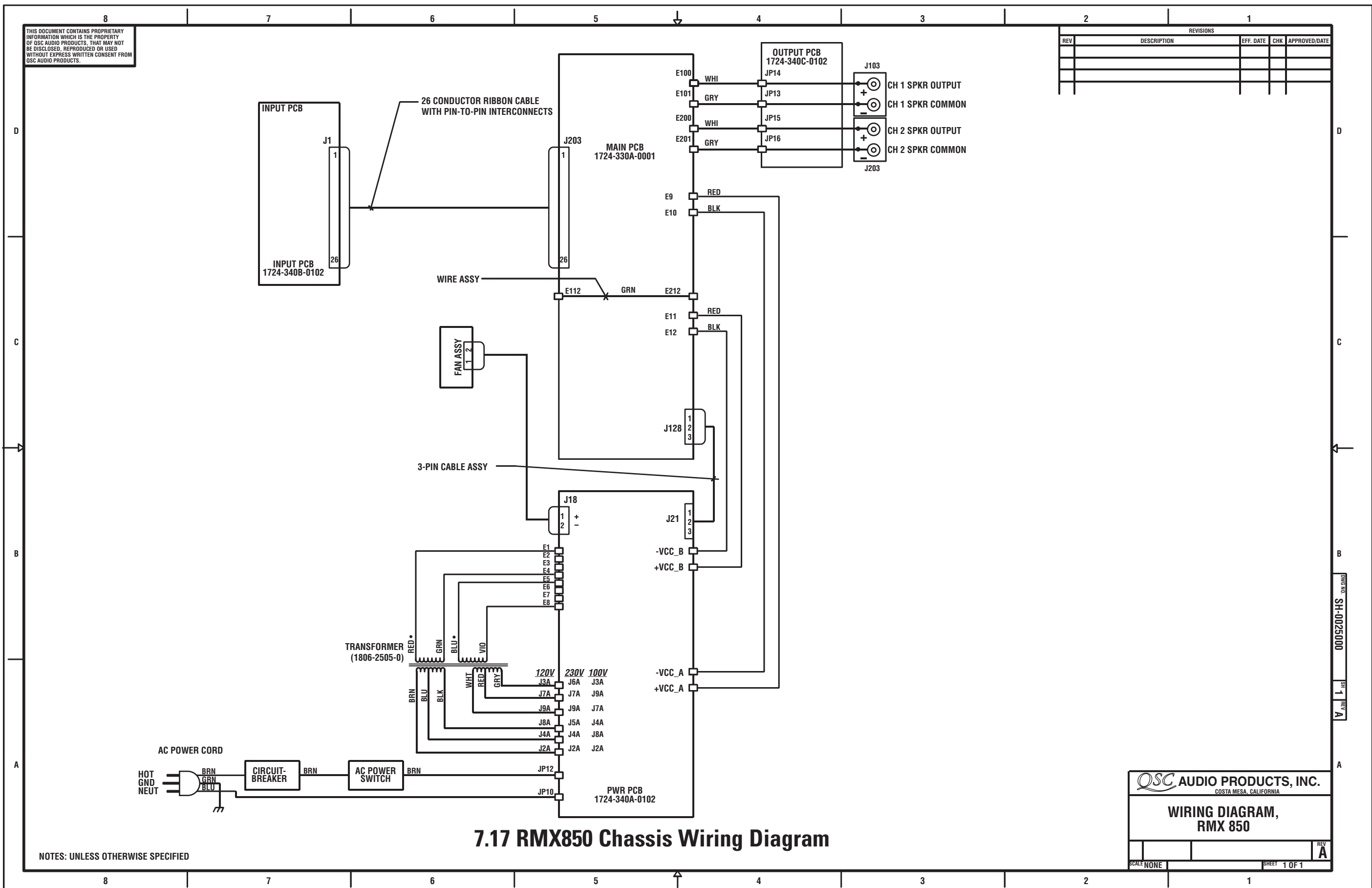

7.17 RMX850 Chassis Wiring Diagram

NOTES: UNLESS OTHERWISE SPECIFIED

**QSC AUDIO PRODUCTS, INC.**  
COSTA MESA, CALIFORNIA

**WIRING DIAGRAM, RMX 850**

SCALE: NONE      SHEET 1 OF 1      REV A

THIS DOCUMENT CONTAINS PROPRIETARY INFORMATION WHICH IS THE PROPERTY OF QSC AUDIO PRODUCTS. THAT MAY NOT BE DISCLOSED, REPRODUCED OR USED WITHOUT EXPRESS WRITTEN CONSENT FROM QSC AUDIO PRODUCTS.

REVISIONS				
REV	DESCRIPTION	EFF. DATE	CHK	APPROVED/DATE

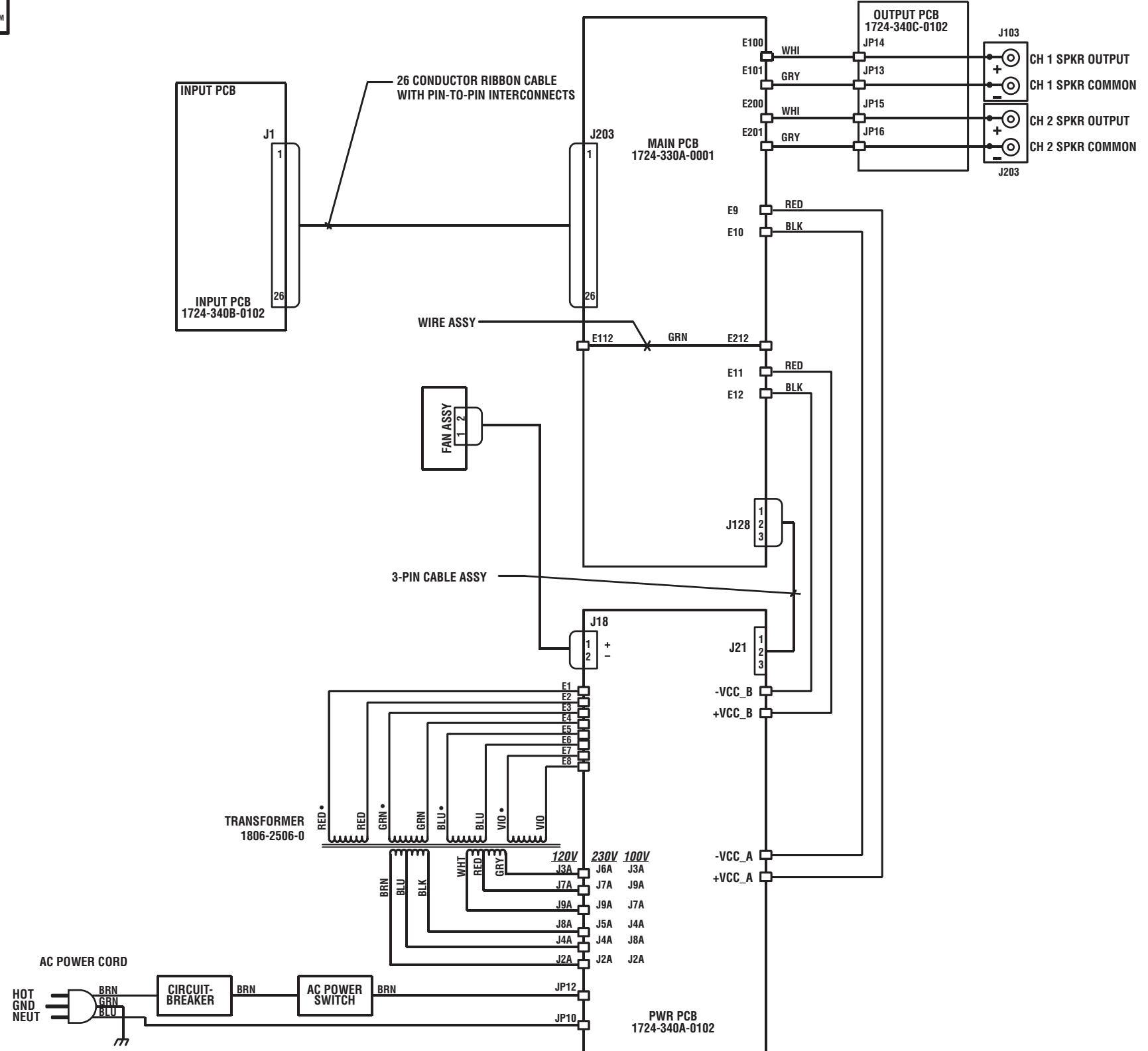

**7.18 RMX1450 Chassis Wiring Diagram**

NOTES: UNLESS OTHERWISE SPECIFIED

**QSC AUDIO PRODUCTS, INC.**  
COSTA MESA, CALIFORNIA

**WIRING DIAGRAM, RMX 1450**

SCALE: NONE      SHEET: 1 OF 1      REV: A

PROJECT: SH-0025000      REV: A

THIS DOCUMENT CONTAINS PROPRIETARY INFORMATION WHICH IS THE PROPERTY OF QSC AUDIO PRODUCTS. THAT MAY NOT BE DISCLOSED, REPRODUCED OR USED WITHOUT EXPRESS WRITTEN CONSENT FROM QSC AUDIO PRODUCTS.

REVISIONS				
REV	DESCRIPTION	EFF. DATE	CHK	APPROVED/DATE
A	PRODUCTION RELEASE PER ECO X MP			

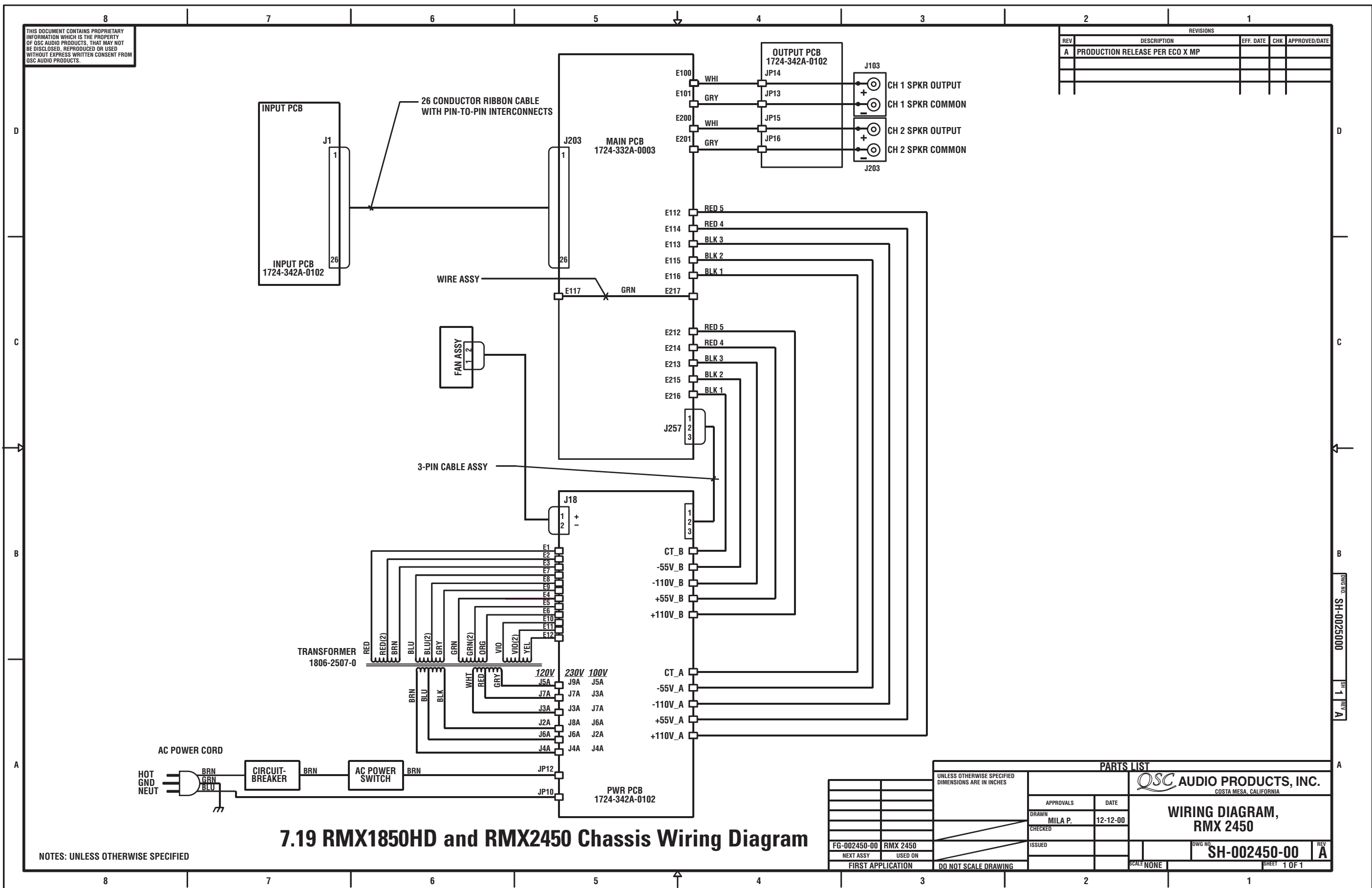

**7.19 RMX1850HD and RMX2450 Chassis Wiring Diagram**

NOTES: UNLESS OTHERWISE SPECIFIED

PARTS LIST			
UNLESS OTHERWISE SPECIFIED DIMENSIONS ARE IN INCHES	APPROVALS	DATE	<b>QSC AUDIO PRODUCTS, INC.</b> COSTA MESA, CALIFORNIA <b>WIRING DIAGRAM, RMX 2450</b>
	DRAWN MILA P.	12-12-00	
	CHECKED		
	ISSUED		
FG-002450-00 RMX 2450			DWG NO. SH-002450-00
NEXT ASSY USED ON			REV A
FIRST APPLICATION			SCALE: NONE SHEET 1 OF 1







“QSC” and the QSC logo are registered trademarks of QSC Audio Products, LLC 1665 MacArthur Blvd. Costa Mesa, CA 92626  
Phone +1 (714) 957-7150 (800) 772-2834 (USA only) FAX +1 (714) 754-6173  
[www.qscaudio.com](http://www.qscaudio.com)