



TS431/431A/431B

Adjustable Precision Shunt Regulator

TO-92

SOT-89

SOT-23

SOP-8



Sink Current Capability up to 100mA

General Description

The TS431/431A/431B integrated circuits are three-terminal programmable shunt regulator diodes. These monolithic IC voltage references operate as a low temperature coefficient zener which is programmable from Vref to 36 volts with two external resistors. These devices exhibit a wide operating current range of 1.0 to 100mA with a typical dynamic impedance of 0.22Ω. The characteristics of these references make them excellent replacements for zener diodes in many applications such as digital voltmeters, power supplies, and op amp circuitry. The 2.5volt reference makes it convenient to obtain a stable reference from 5.0volt logic supplies, and since The TS431/431A/431B operates as a shunt regulator, it can be used as either a positive or negative stage reference.

This series is offered in 3-pin TO-92, SOT-89, SOT-23 and SOP-8 package.

Features

- ◇ Precision Reference Voltage
 - TS431 2.495V±2%
 - TS431A 2.495V±1%
 - TS431B 2.495V±0.5%
- ◇ Equivalent Full Range Temp. Coefficient: 50ppm/°C
- ◇ Programmable Output Voltage up to 36V
- ◇ Fast Turn-On Response
- ◇ Sink Current Capability of 1.0 to 100 mA
- ◇ Low Dynamic Output Impedance: 0.22Ω
- ◇ Low Output Noise

Standard Application

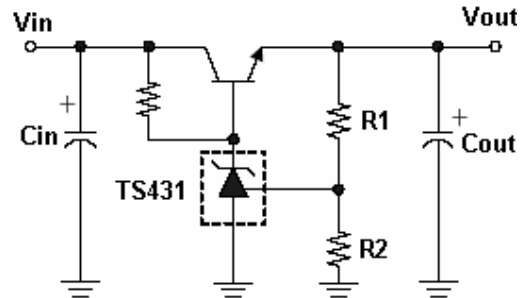

$$V_{out} = V_{ref} * (1 + R1 / R2)$$

Ordering Information

Part No.	Operating Temp. (Ambient)	Package
TS431xCT	-20 ~ +85 °C	TO-92
TS431xCY		SOT-89
TS431xCX		SOT-23
TS431xCS		SOP-8

Note: Where **x** denotes voltage tolerance.

Blank: ±2%

A: ±1%

B: ±0.5%

Block Diagram

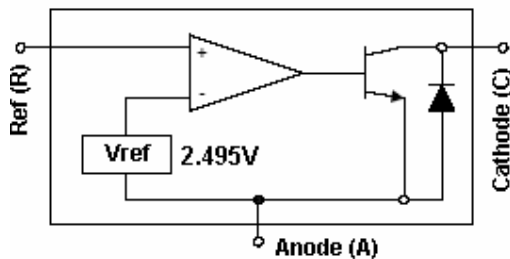

Pin Assignment

Pin No.				Pin Description
TS431/A/BCT	TS431/A/BCY	TS431/A/BCX	TS431/A/BCS	
1	1	1	8	Reference
2	2	3	2,3,6,7	Anode
3	3	2	1	Cathode
			4,5	Non connect



Absolute Maximum Rating							
Cathode Voltage (Note 1)		Vka	37	V			
Continuous Cathode Current Range		Ik	-100 ~ +150	mA			
Reference Input Current Range		Iref	-0.05 ~ +10	mA			
Power Dissipation (Note 2, 3)	TO-92	Pd	0.625	W			
	SOT-89 / SOP-8		0.5				
	SOT-23		0.3				
Operating Junction Temperature Range		Tj	+125	°C			
Storage Temperature Range		T _{STG}	-65 ~ +150	°C			
Note 1: Voltage values are with respect to the anode terminal unless otherwise noted.							
Note 2: Tj Max = 150 °C							
Note 3: Rating apply to ambient temperature at 25 °C							
Recommend Operating Condition							
Cathode Voltage Range		Vka	Ref ~ 36	V			
Cathode Current Range (for regulation)		Ik	1 ~ 100	mA			
Electrical Characteristics							
(Ta=25 °C, unless otherwise specified.)							
Parameter		Symbo	Test Conditions	Min	Typ	Max	Unit
Reference voltage	TS431	Vref	Vka =Vref, Ik=10mA (Figure 1)	2.450	2.495	2.550	V
	TS431A			2.475		2.525	
	TS431B			2.487		2.513	
Deviation of reference input voltage, over temp. (Note 4)		ΔVref	Ta = full range Vka =Vref, Ik=10mA (Figure 1)	--	3	17	mV
Reference Input current		Iref	R1=10KΩ, R2=∞, Ika=10mA (Figure 2)	--	0.7	4.0	uA
Radio of change in Vref to change in cathode Voltage		ΔVref / ΔVka	Ika=10mA, Vka = 10V to Vref, Vka = 36V to 10V (Figure 2)	--	-1.4 - 1.0	-2.7 - 2.0	mV/V
Deviation of reference input current, over temp.		Iref(DEV)	Ta= full range R1=10KΩ, R2=∞, Ika=10mA (Figure 2)	--	0.4	1.2	uA
Minimum operating cathode current		Ika(min)	Vka=Vref (Figure 1)	--	0.4	0.6	mA
Off-state Cathode Current		Ioff	Vref=0V (Figure 3) Vka=36V	--	--	1.0	uA
Dynamic Output Impedance		Zka	f<1KHz, Vka=Vref Ika=1mA to 100mA (Figure 1)	--	0.22	0.5	Ω

Electrical Characteristics (continued) (Ta=25 °C, unless otherwise specified.)

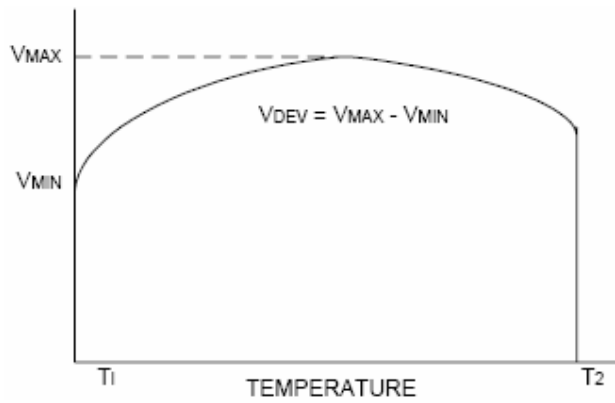

Note 4. Deviation of reference input voltage, VDEV, is defined as the maximum deviation of the reference over the full temperature range.

The average temperature coefficient of the reference input voltage αV_{ref} is defined as:

$$|\alpha V_{ref}| = [V_{DEV} / V_{ref}(25^\circ C)] * 10^6 / T2 - T1 \dots\dots\dots (PPM/^\circ C)$$

Where: T2-T1 = full temperature change.

αV_{ref} can be positive or negative depending on whether the slope is positive or negative.

Example: Maximum Vref=2.496V at 30°C, minimum Vref=2.492V at 0°C, Vref=2.495V at 25°C, $\Delta T=70^\circ C$

$$|\alpha V_{ref}| = [4mV / 2495mV] * 10^6 / 70^\circ C \approx 23ppm/^\circ C$$

Note 5. The dynamic output impedance, Rz, is defined as:

$$|Zka| = \Delta Vka / \Delta Ika$$

When the device is programmed with two external resistors R1 and R2 (see Figure 2). The dynamic output impedance of the overall circuit, is defined as :

$$|Zka| = \Delta v / \Delta i \approx Zka | * (1 + R1 / R2)$$

Test Circuits

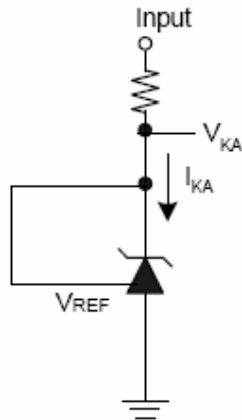
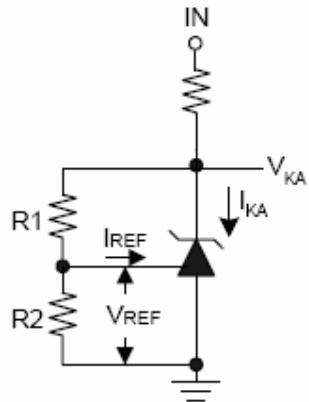

Figure 1. Vka = Vref



$$Vka = Vref(1+R1/R2)+Iref * R1$$

Figure 2. Vka > Vref

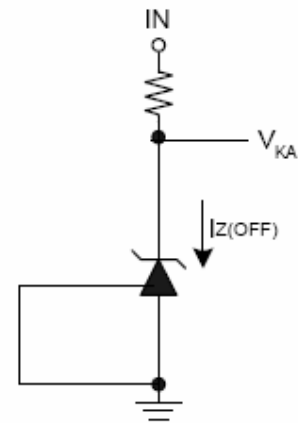
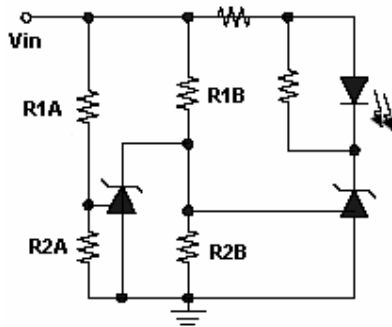

Figure 3. Off-state Current

Application Examples



LED on when $\text{low limit} < V_{in} < \text{high limit}$
 $\text{low limit} = V_{ref} (1 + R1B / R2B)$
 $\text{high limit} = V_{ref} (1 + R1A / R2A)$

Figure 4. Voltage Monitor

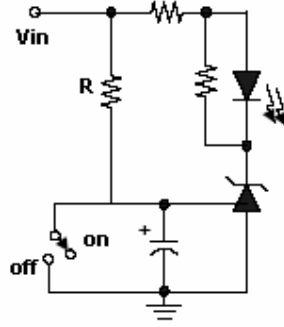

$\text{Delay} = RC \ln (V_{in} / V_{in} - V_{ref})$

Figure 5. Delay Timer

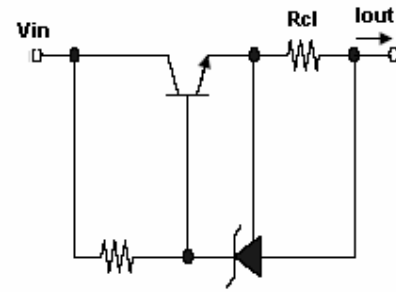

$I_{out} = V_{ref} / R_{cl}$

Figure 6. Current limiter or Current Source

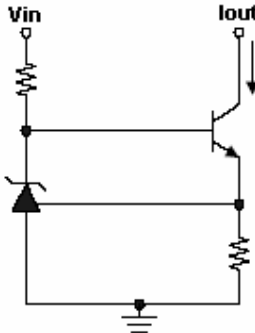

$I_{out} = V_{ref} / R_s$

Figure 7. Constant Current Sink

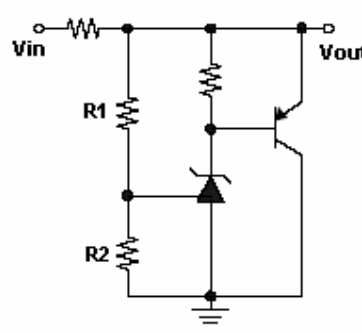

$V_{out} = V_{ref} * (1 + R1 / R2)$

Figure 8. Higher Current Shunt

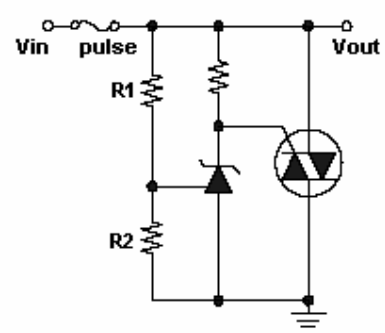

$\text{Limit} = V_{ref} * (1 + R1 / R2)$

Figure 9. Crow Bar

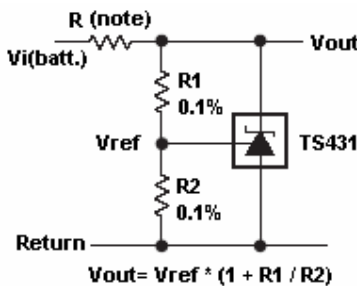

$V_{out} = V_{ref} * (1 + R1 / R2)$

note: R should provide cathode current $> 1\text{mA}$ to the TS431 at minimum $V_{i(\text{batt.})}$

Figure 10. Shunt Regulator

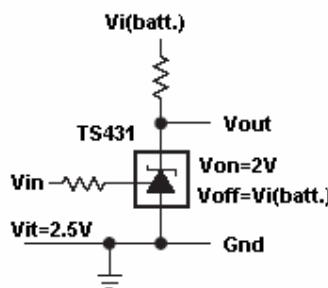
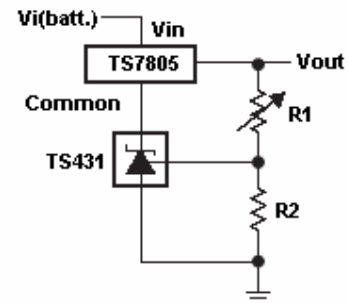

Figure 11. Single Supply Comparator v.s. Temp.-Compensated Threshold



$V_{out} = V_{ref} * (1 + R1 / R2)$
 minimum $V_{out} = V_{ref} + 5V$

Figure 12. Output Control of a Three-Terminal Fixed Regulator

Application Examples

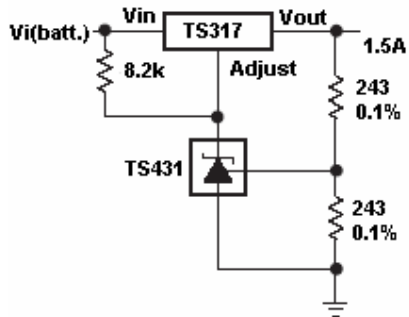

Figure 13. Precision 5V/1.5A regulator

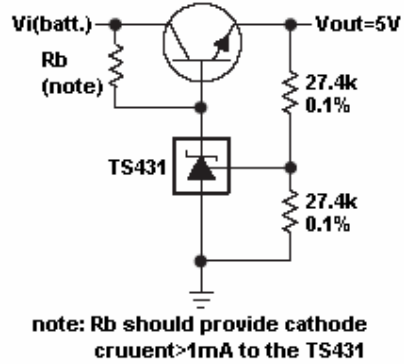

Figure 14. Efficient 5V Precision Regulator

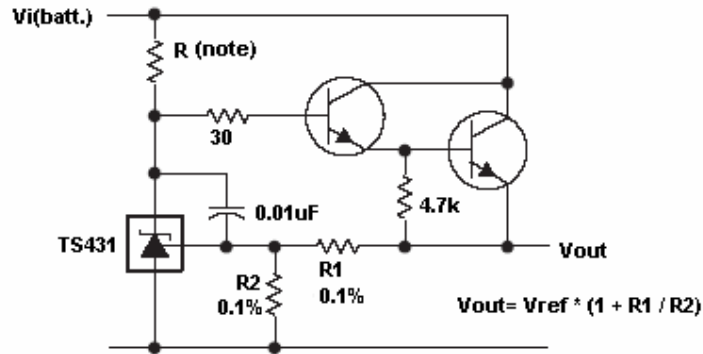
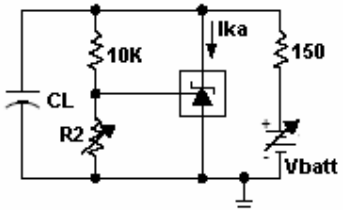
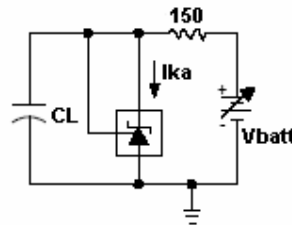
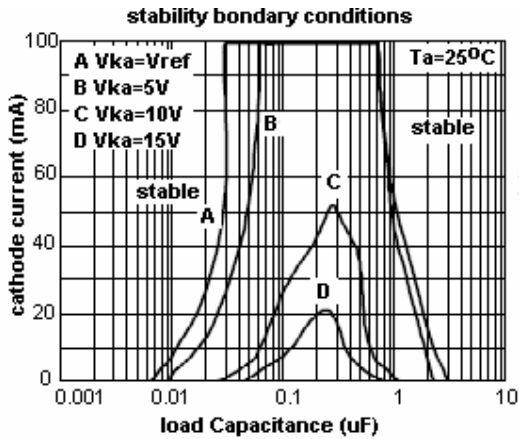
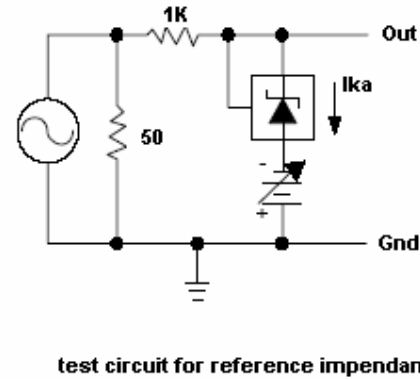
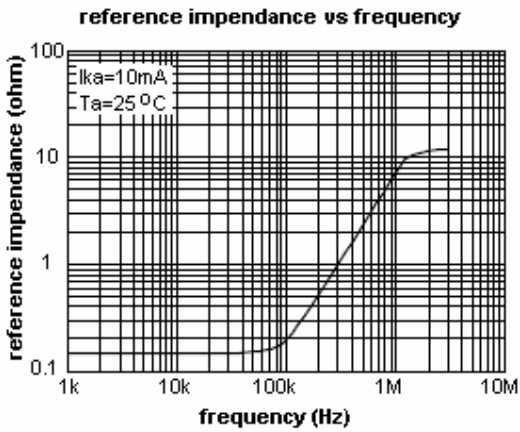
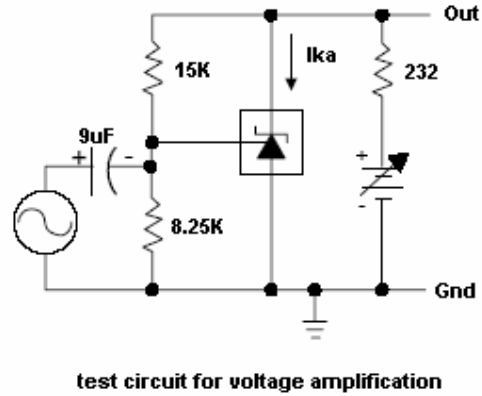
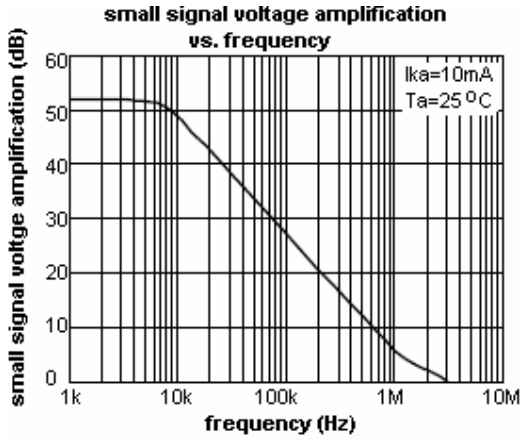

Figure 15. Precision High Current Series Regulator

Typical Performance Characteristics



the area under the curves represent conditions that may cause the device to oscillate. for curves B, C and D, R2 and V+ were adjusted to establish the initial Vka and Ika conditions with CL=0. Vbatt and CL were then adjusted to determine the ranges of stability.

TO-92 Mechanical Drawing

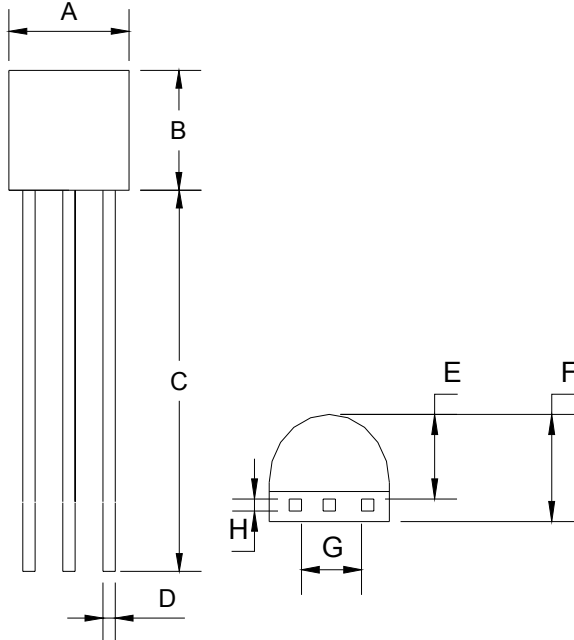

TO-92 DIMENSION				
DIM	MILLIMETERS		INCHES	
	MIN	MAX	MIN	MAX
A	4.30	4.70	0.169	0.185
B	4.30	4.70	0.169	0.185
C	14.30(typ)		0.563(typ)	
D	0.43	0.49	0.017	0.019
E	2.19	2.81	0.086	0.111
F	3.30	3.70	0.130	0.146
G	2.42	2.66	0.095	0.105
H	0.37	0.43	0.015	0.017

SOT-89 Mechanical Drawing

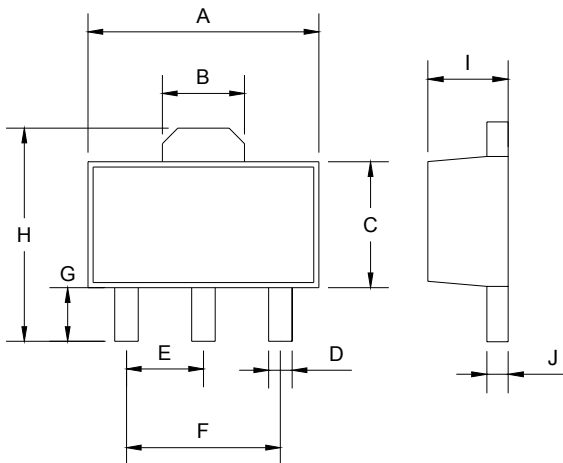

SOT-89 DIMENSION				
DIM	MILLIMETERS		INCHES	
	MIN	MAX	MIN	MAX
A	4.40	4.60	0.173	0.181
B	1.50	1.7	0.059	0.070
C	2.30	2.60	0.090	0.102
D	0.40	0.52	0.016	0.020
E	1.50	1.50	0.059	0.059
F	3.00	3.00	0.118	0.118
G	0.89	1.20	0.035	0.047
H	4.05	4.25	0.159	0.167
I	1.4	1.6	0.055	0.068
J	0.35	0.44	0.014	0.017

SOT-23 Mechanical Drawing

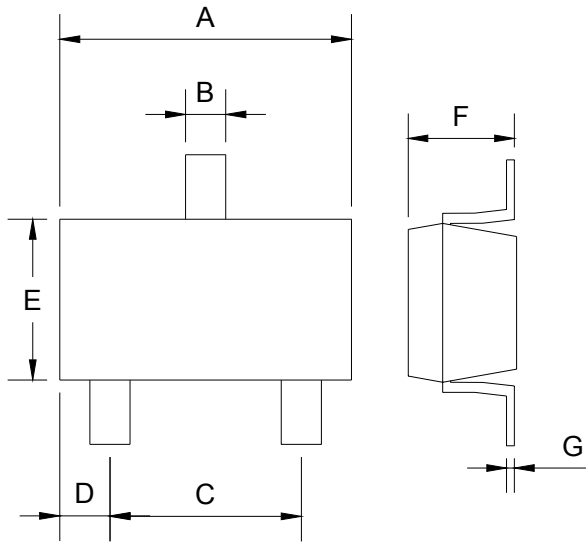

SOT-23 DIMENSION				
DIM	MILLIMETERS		INCHES	
	MIN	MAX	MIN	MAX
A	2.88	2.91	0.113	0.115
B	0.39	0.42	0.015	0.017
C	1.78	2.03	0.070	0.080
D	0.51	0.61	0.020	0.024
E	1.59	1.66	0.063	0.065
F	1.04	1.08	0.041	0.043
G	0.07	0.09	0.003	0.004

SOP-8 Mechanical Drawing

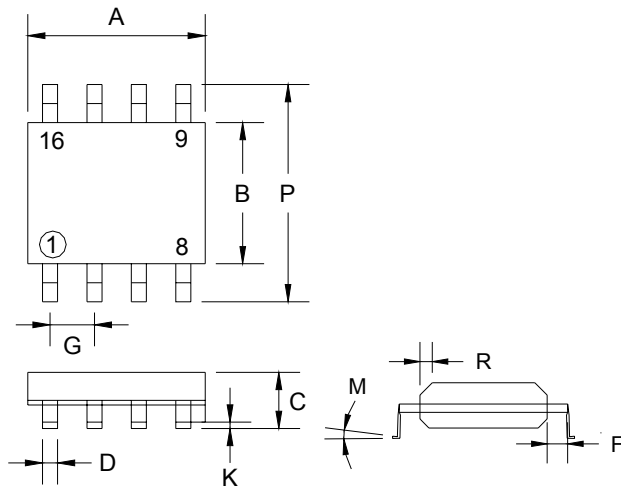

SOP-8 DIMENSION				
DIM	MILLIMETERS		INCHES	
	MIN	MAX	MIN	MAX
A	4.80	5.00	0.189	0.196
B	3.80	4.00	0.150	0.157
C	1.35	1.75	0.054	0.068
D	0.35	0.49	0.014	0.019
F	0.40	1.25	0.016	0.049
G	1.27 (typ)		0.05 (typ)	
K	0.10	0.25	0.004	0.009
M	0°	7°	0°	7°
P	5.80	6.20	0.229	0.244
R	0.25	0.50	0.010	0.019