

6 Digit Frequency Counter



Introduction [construction-1](#) [Construction-2](#) [Construction-3](#)

[Download this project in PDF](#)

Note

This " 6 Digit Frequency Counter " circuit and PCB was designed by Laurier Gendron. It is being made available to hobbyists for personal development only. It cannot be used for commercial purposes of any kind without previous written permission. (10 Feb.2001)

Introduction

Based on the application of the three digit decoder driver chip MC14553 published in the Motorola data manual I undertook the task of designing a 6-digit frequency meter and the results were excellent , simple enough and at a cost of well under \$ 50.00 Canadian.

Since the Frequency counter may require as much as 250ma of current when all digits are illuminated it was designed as a bench instrument complete with a regulated power supply as described later. The transformer used was retrieved from an ancient digital alarm clock . Although a clocking signal could have been derived from the AC supply line , a digital clock oscillator was incorporated into the design to accommodate a battery pack supply instead of an AC supply source as an alternative. .

Following the design application of the Digital Capacitance Meter , the digital display read out section needed to be expanded by adding a second set of three digits for a total of six digits to accomplish my goal of being able to count up to 1MHz without adding many stages of frequency division .

Once this accomplished I decided to increase the capability by adding one dividing stage to obtain a reading up to 10 MHz minus one count (9.99999MHz) and this was accomplished by adding only on IC and one switching stage, but with the basic CMOS IC's it tends to bog down at about 4mHz . This problem was later solved by a hobbyist who used the Phillips HCFxxxx Cmos and kindly suggested the change and the much improved results . [See modified part list](#) . .

You can make a search and download application data sheets for all the IC's used in this project from [ON Semiconductors](#)

The circuit

In addition to the six digits counter circuit for display , the measurement of a frequency can be achieved with only four additional CMOS IC's ,MC or CD4521, two MC14093 (Motorola) , one MC or CD4017 . The six digits counter is made of two CMOS IC's MC14553 and two MC or CD14543 , six common Cathode digital displays and a few other parts . A complete [list](#) of parts is provided .

Logic Circuit Description

As a reference you may wish to open up a [new window](#) to view the circuit while reading the description.(The window size is adjustable)

- The logic circuit is designed to accomplish the following ;
 - a) Condition the input stage to accept a sine, square, pulse or triangle signal.
 - b) Amplify a weak signal voltage to a level required for good processing.

- c) Attenuate any high level signal to a pre-determined level so as not to overload the permissible logic input voltage level .
- d) Shape most frequency signals to be acceptable by the counter section for stable processing .
- e) Provide for a timing sequence interval to enable the counter to accumulate a total count that accurately reflects the frequency being measured.

The input is fed to Q1 base through R26 and C15, the amplified signal from the collector of Q1 is decoupled by C6 and connected to pin 8-9 of IC3 . This circuit gain is set to enable a linear amplification from 1Hz to beyond 5 MHz into a MC14093 . On its own , the amplified signal level is not sufficient to trigger the MC14093 and a pull-up resistor is used to raise the voltage reference level sufficiently to trigger the MC14093 . This set-up is very stable and immune to noise that long leads can cause or from other sources and also insure that the counter will auto zero when not signal is present .

The output of IC-3 is taken from pin 3 (x1) and its one output is all that is require for a maximum count of 999,999 hertz which in this case can be connected directly to IC-2 gate D pins 12/13.

Important Notes :

- Ensure the polarity C6 and C15 is as shown otherwise you will not be able to obtain a proper signal .
- The amplifier circuit works best with a MC14093 (Motorola) for IC-3 for a low 300 millivolts input as it has a lower treshhold voltage (4.4V typical) than a (Generic brand) CD4093 (6.2V typical) .
- A CD 4093 can be used for C3 but the sensitivity will be degraded . (Remember all ICs are not created equal) and the count will be limited to 1MHz .

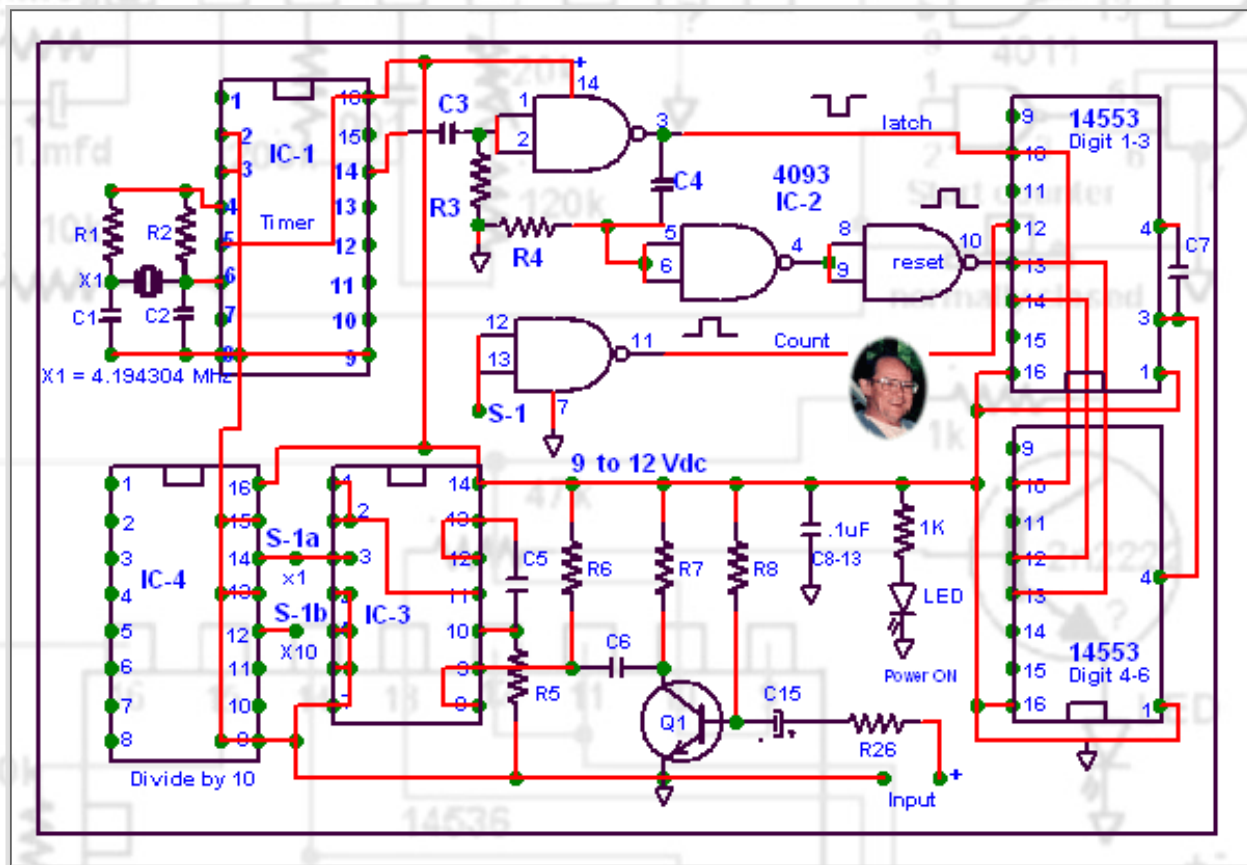

The output of IC-3 from pin 3 is sent to IC-4 pin 14 . C-4 is a CMOS 4017 Decade Counter and is used as a frequency divider , it is configured to divide any frequency by 10 .The maximum operating frequency of IC-4 (CMO4017) is 12 MHz . The divided frequency is taken from pin 12 (x10) and connected via S1a to gate D pins 12/13 of IC-2 . Switch S1 is used to select the output of either IC-3 pin 3 for a maximum count of 999,999 Hz or the output of IC-4 pin 12 for a count of up to 10 MHz minus one which in this case would be displayed as 999,999 kHz .

The selected output (x1) is fed to the input of gate D of IC-2 as mentioned earlier , IC-2 is used to shape all the input signals required by the three digit counters CMOS MC14553 described below .

In order to be able to provide timing pulses to the counter an oscillator is required , IC-1 CMOS 4521 with its appropriate crystal (see parts list - xtal) delivers a one (1) pulse per second taken from pin 14 and is delivered to pin 1 & 2 of gate A .

As we can see IC-2 and IC-3 are used with the combination of C3,C4,C5,R3,R4 ,R5 to condition and invert the pulses where required to the counter as it requires exact timing and pulses shape for the stable operation of the counter.

Option

Perhaps all you need is a 1Hz to 1MHz counter ! While still using the same Layout and PCB all you need to do is the following simple modifications :

- 1... Omit IC- 4 (4017) and connect IC3 (MC14093) pin 3 (S1a -x1) directly to pin 13 of IC2 .
- 2... Change S1 from a DPDT to a SPST for power ON only .
- 3... For the lower range application , better sensitivity and lower frequency can be obtained by using values shown for the logic input circuit to be used for 1Hz to 1mHz counter as shown below .

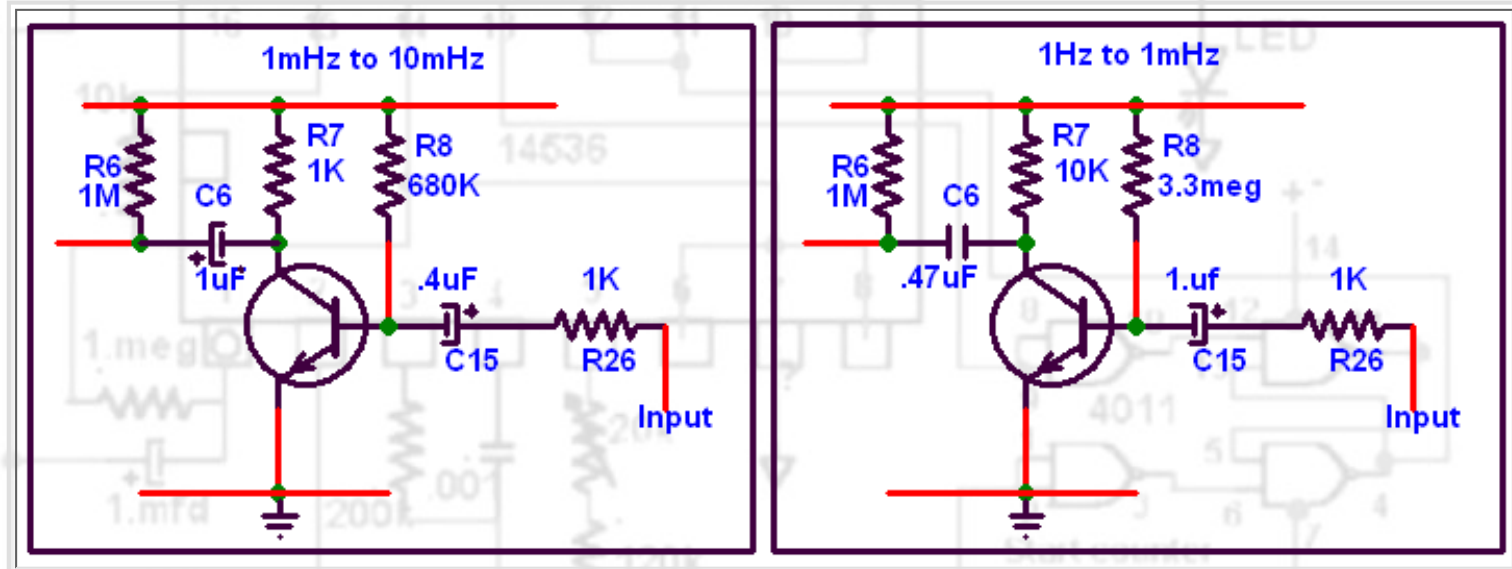

Test Oscillator

I include below a small oscillator circuit that can be used to test your high frequency range , any crystal up to 50 MHz can be used , also very handy as crystal checker which could be incorporated in your project with a means to plug in your crystal for direct frequency reading with a simple connecting switch to the input .

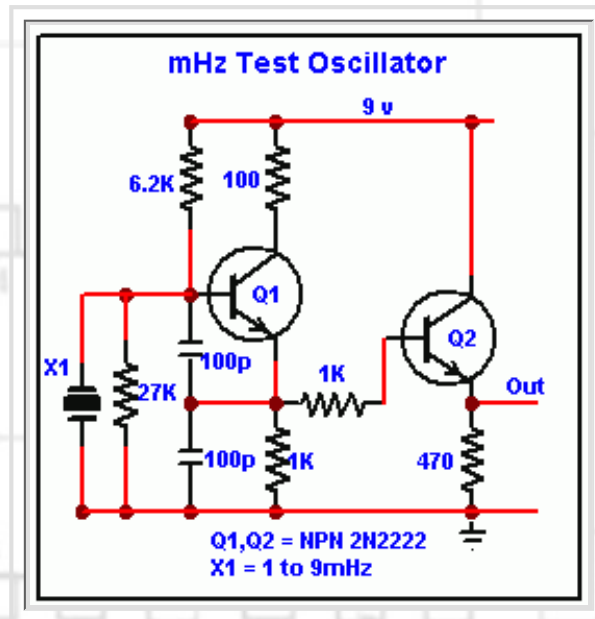

The Counter Display

As a reference you may wish to open up a [new window](#) to view the circuit while reading the description.(The window size is adjustable)

● We need to know how the counter display operates in order to make use of it, the heart of the counter is the MC14553 which is a three-digit BCD counter and with the use of the MC14543 a BCD-to-seven segment decoder / driver will decode and activate the proper digit segments to display a maximum display count of 999.

To do this the MC14553 needs three input signals, a positive (high) pulse to the Latch input (pin #10) to enable storage of pulses to be stored into the latch and a Reset (pin # 13) pulse (high) to reset the counter . The total count desired is controlled by the Latch action which sets the time we require to insert the amount of pulses to the Counter (pin #12) to be displayed.

When the latch is high the count starts and when the Latch is low (zero) the count is stopped and the total of pulses accumulated in the latch are displayed then a positive pulse is required to the Reset to clear the Latch , the speed of this process is controlled by an internal 100 kHz oscillator which is determined by the .001 capacitor C7 connected between pin # 3 and pin # 4 of IC-6 .

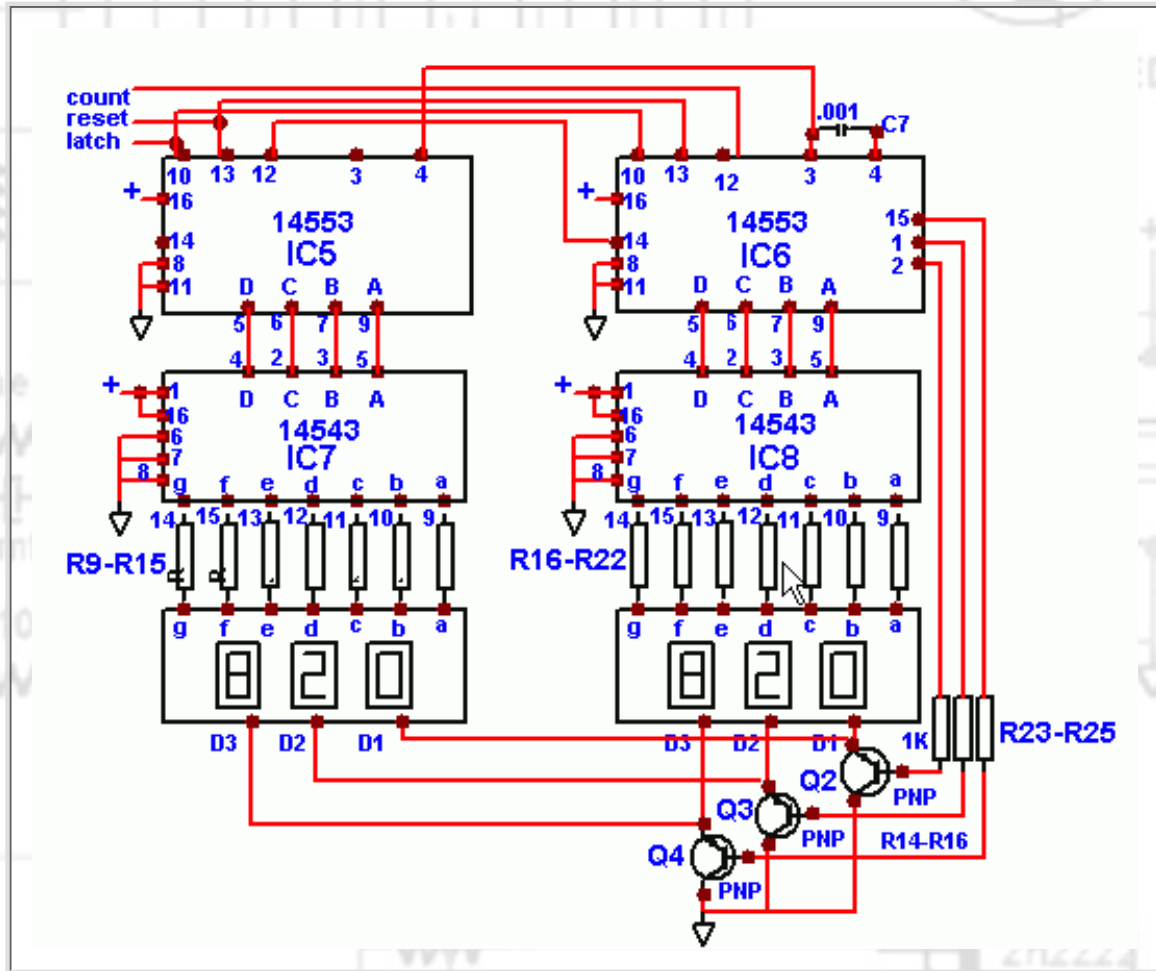

To display six (6) digit we simply add an exact duplicate of the three digit circuit and connect the overflow from pin 14 of IC-6 to pin 12 of IC-5 as well as carry the oscillator signal from pin 3 of IC-6 to pin 4 of IC-5 and duplicate the inputs of the " Count, Reset, Latch " as well.

Notice that only one set of driving transistors of three is still used but they are now connected to the second set of digit as well **BUT** the segment connections of each three digit must be kept separate and connected to its dedicated digit driver IC-7 and IC-8 as shown.

Introduction [construction-1](#) [Construction-2](#) [Construction-3](#)

[HOME](#)

6 Digit Frequency Counter

[Introduction](#)
[construction-1](#)
[Construction-2](#)
[Construction-3](#)

Part List___ The values listed are for a 1Hz to 10mHz counter. For a 1Hz to 1mHz counter the logic input circuit values must be changed . see Logic input options

| Circuit Parts list | |
|---|---|
| R1,R3= 10K R2 = 3.3 meg R5 =27K R6 =1M R4 , R7 =1K R8 =250K R9 to R22 = 180.0 (see text) R23 ,R24, R25 ,R26 = 1K | C1 = 82 pF C2 = 22 pF C3,C4,C7 = .001 uF C5 =.005 uF C6 = .47uF C8 to C13= 0.1 uF (IC By-Pass) C14 , C15 = 1.uF Tantalum Q1 = NPN 2N2222 Q2 - Q4 = PNP 2N3906 or similar X1 = Crystal Freq. 4.194304 MHz |
| IC1 = CD4521 24 stage frequency divider IC2 ,IC3 = (for 1mHz) CD or MC4093 , Quad " NAND " Schmitt trigger IC2, IC3 = (For 12mHz counter) HEF14093 (Do not substitute) IC4 = (For 12mHz) HEF4017 Decade counter/divider ,(do not substitute) IC5,IC6 = MC14553 (Motorola) 3-digit BCD counter IC7,IC8 = MC 4543 or CD4543 Digit driver 6 each LED displays , Common cathode (see text) S1 = Miniature Toggle switch DPDT Center OFF (see text -graphic) Jack = 2 each , input ,banana type | |

Construction

● *This project may be not suitable for the beginners as a certain amount of experience is required to achieve a good operating system , nevertheless the following construction suggestions should help everyone in preventing most problems but do not expect to get any tuition from the designer.*

- **Unless you never make mistakes use sockets for all the IC's.**
- **Keep all leads especially capacitor leads as short as physically possible.**

- **Best operating voltage is a regulated 9 volts DC supply .**
- **Use two 14 pins IC socket for R9 to R22 for quick adjustments . No need to mess up the PC .**
- **If an external power supply is used AC or DC install a regulator as well as a large filtering capacitor (1000 uF) for stability.**
- **The transistors used can be any general purpose PNP small signal transistors similar to the one listed but pins layout is to be taken in consideration to fit the PCB if used .**
- **The switch S1 is a miniature DP3P with Center OFF . As it is used to apply power to the circuit as well as signal range selection -it must be rated at 120v/3A . See illustrated application with power supply section .**
- **The following will produce noise ; bad capacitors , poor wiring, cold solder , bad connections , noisy supply lines , dirty switch contacts .**

LED Displays

● The circuit was designed to use Common Cathode LED displays which I already had in my junk box . Any size and colour can be used as long as you can get the right colour filter for their use.

Important Note : For common cathode Pins 6 of the two 14543 ICs (IC-7 and IC-8) must be connected to the negative bus by bridging with a bit of solder to pins 7 and 8 of each IC.

Using common anode display

The design can easily be modified for the use of Common Anode LED displays as follows ; (please refer to the [Circuit layout](#))

- 1 - Still using PNP transistors , reverse their polarity so that the collector is now connected to digits 1 to 6 , the base connections remain the same as connected to the 1K resistors and the emitter will now be connected to the positive bus by doing the changes described in para 2.
- 2 - Remove Jumper 1 (J1) and relocate and solder C13 in its place , install a jumper J2 at C13 former position . The transistors emitter are now connected to the positive instead of the negative bus .
- 3 - Install jumpers J3a and J3b from pin 6 of the 14543 IC's (IC-7 and IC-8) to the positive bus as shown .

R9 to R22 are the segments current limiting resistors connected in series from the segment drivers IC-7 and; 8 . A maximum current of 10 ma per segment is recommended for long operating life of the LED displays , a 180 to 200 ohm resistor per segment should be used and can be increased in value as long as the brightness is acceptable thus saving on the current supply source .

To ease the burden of connecting that many resistors I used two 14 pins Dip sockets as shown in the PC layout section and installed two 7 x 181 ohm isolated resistance Dip (called SIP ,see parts list) This leaves you the option for easy adjustment of the brightness

by substitution if required later depending on the LED displays that you use.

Display

● Shown below is a description of multiplexing the six LED digit displays . You will notice that two sets of three displays segments are interconnected and that the six digit common anodes or cathodes are connected in two set of three digits as shown to be controlled by the three digit select transistors .

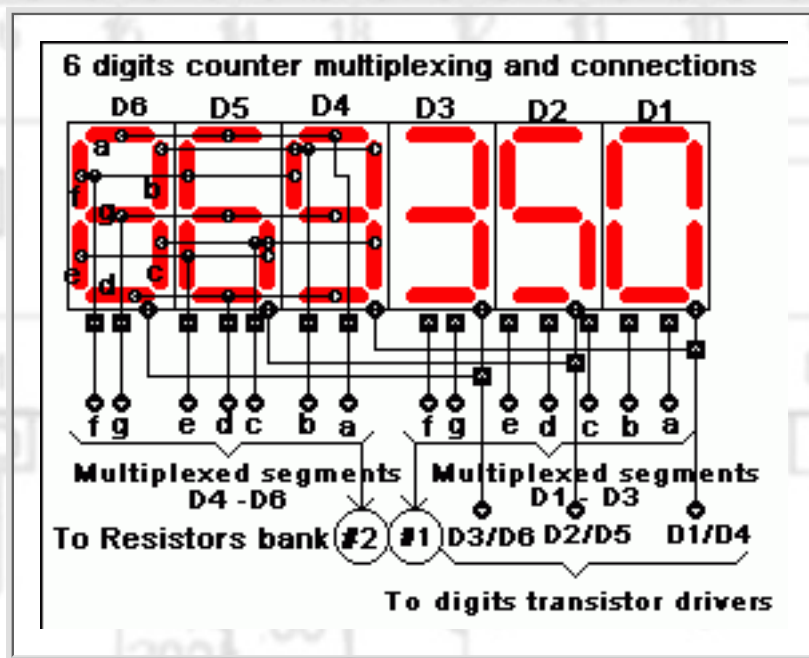

Example of single (with jumpers in red) or double layer PCB for six digits , size .56" common anode , standard pin layout .

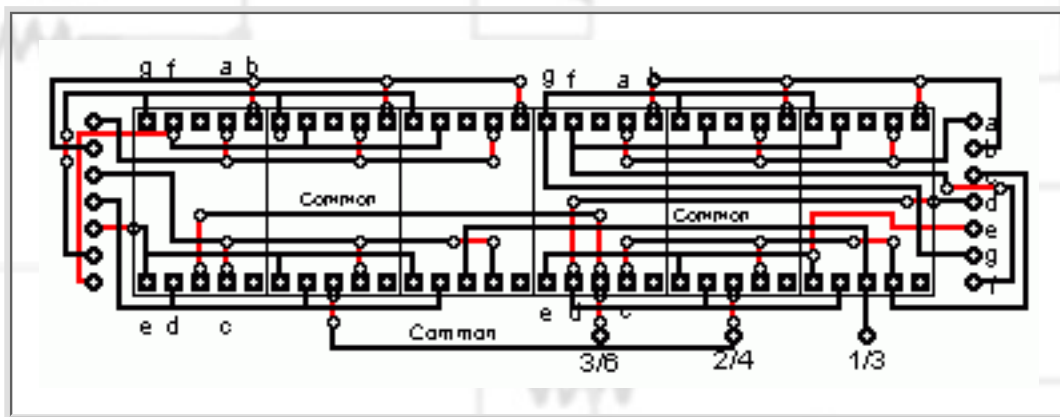

Because of the pins arrangement of some digit display it is sometime difficult to do a proper job of interconnecting , for that reason you might be able to locate already multiplexed modules (Sticks) of three or four digits that you can use . If three are hard to find four digit modules are readily available for a slightly higher price and can be used by omitting connection to the first and last digit of each module when set end to end therefore using only the six center digits . From this point it is a simple task of interconnecting the common pins as required .

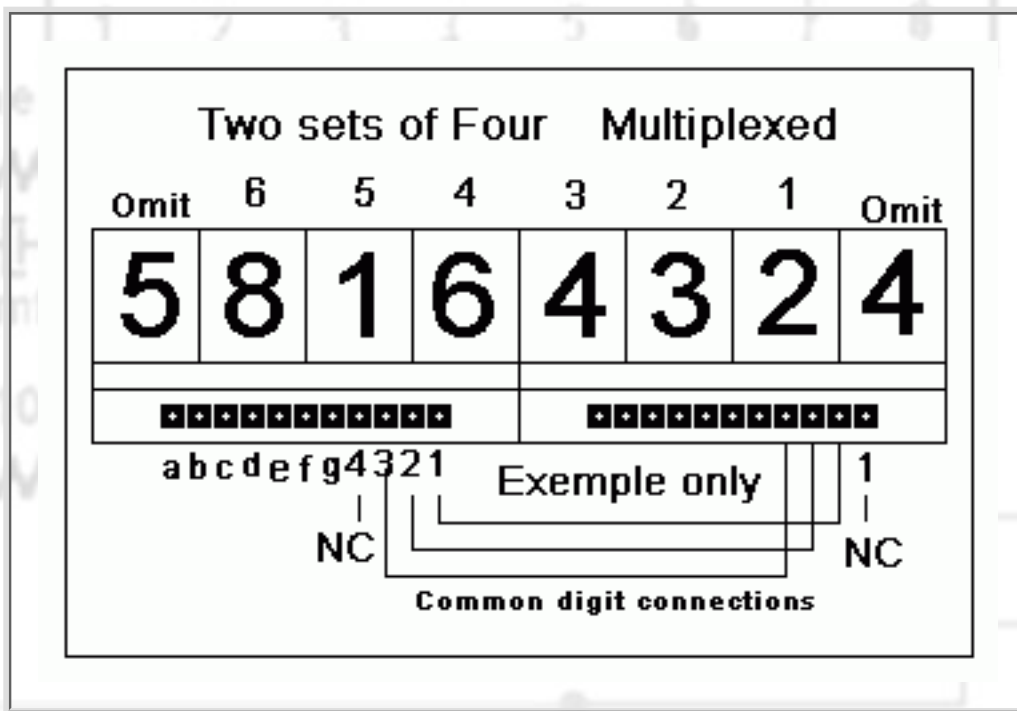

[Introduction](#)
 [construction-1](#)
 [Construction-2](#)
 [Construction-3](#)

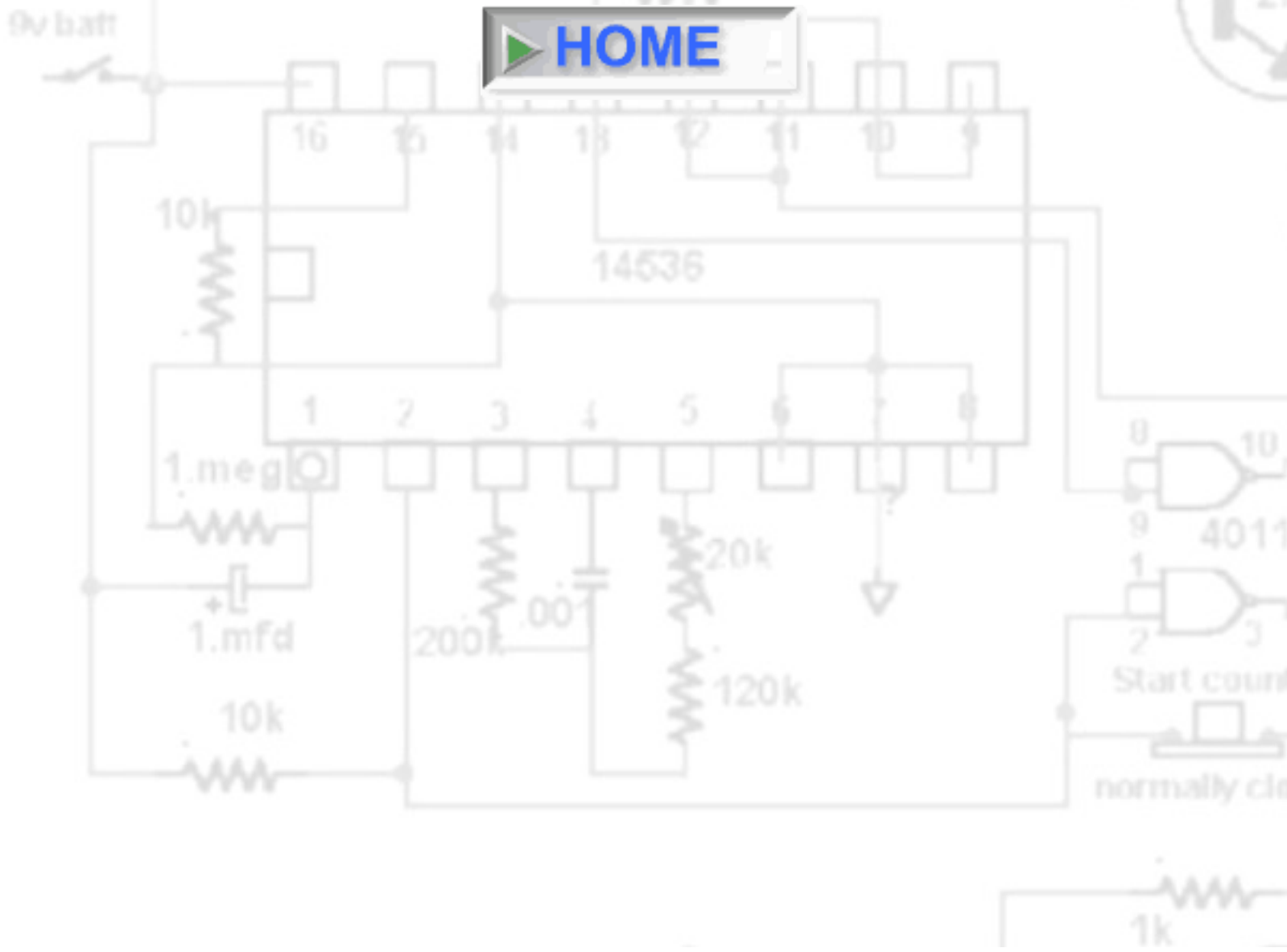

[Introduction](#) [construction-1](#) [Construction-2](#) [Construction-3](#)

PCB Layout

Below is the updated (Sept-9-07) layout for the six digit frequency counter . The layout reflects the designed circuit for common cathode displays with details of parts and jumpers as indicated for modifications as described previously for using common anode displays . An optional regulated 9 VDC power supply input layout as been added if an external supply is to be used . The input is fully rectified to accept external 12V AC or DC supply at the bridge input.

The PCB has been designed into two separate PC boards that can be easily connected with jumpers or short wires . This to allow for a flexible installation at will in a small enclosure . On the other hand a single board can be made that would require a larger surface area and larger enclosure .

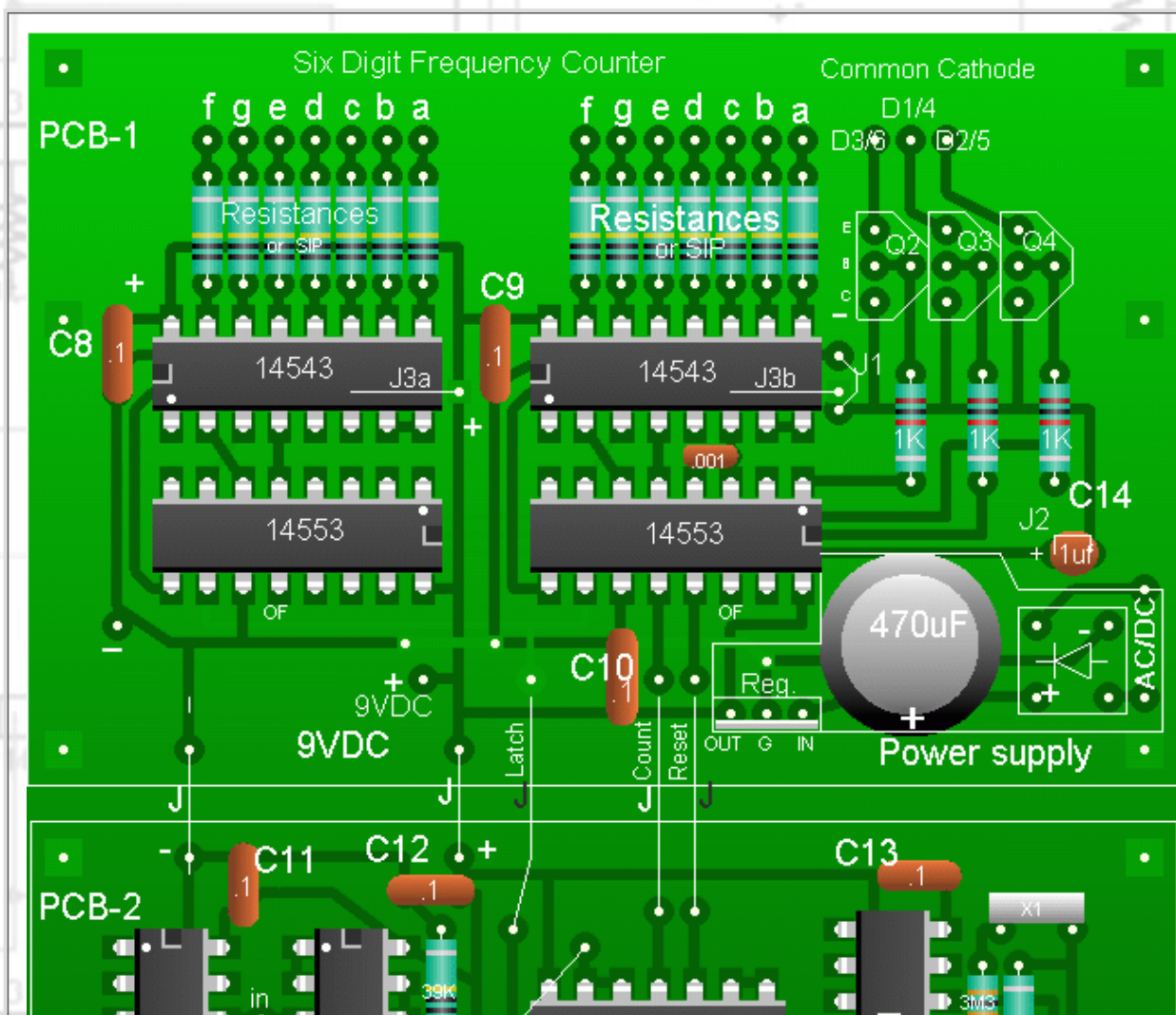

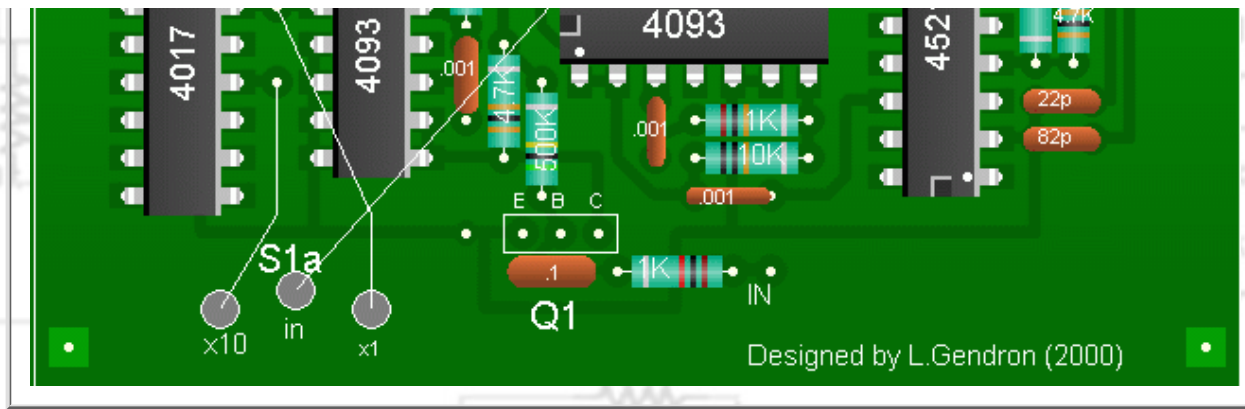

The upper part is the digital display circuitry and the lower part is the input and signal conditioning .

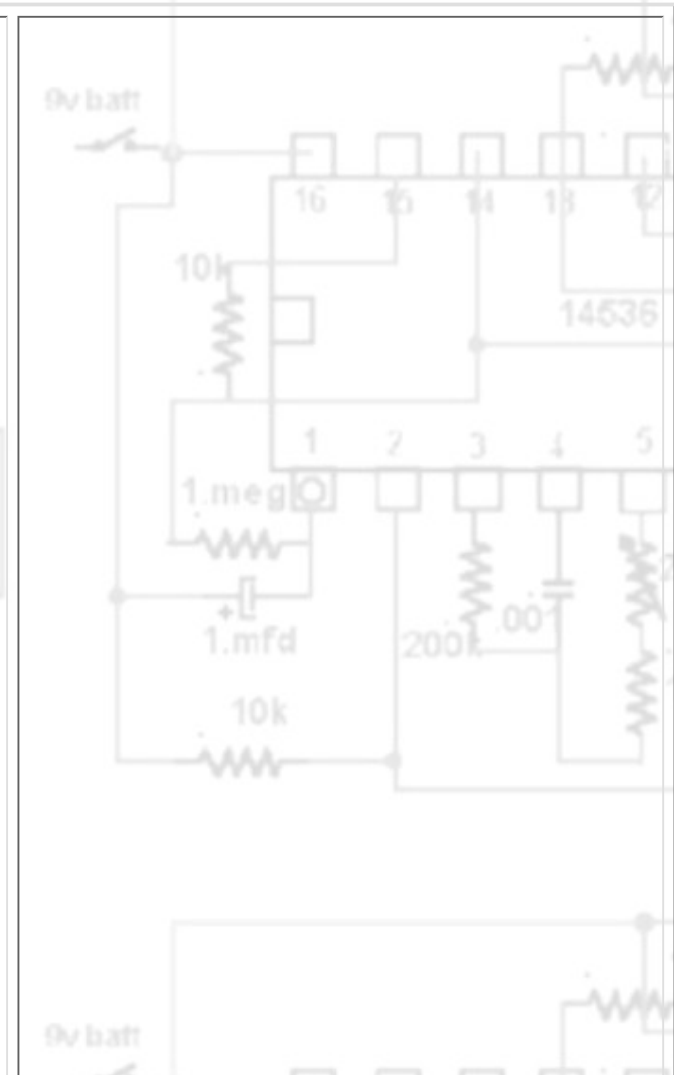
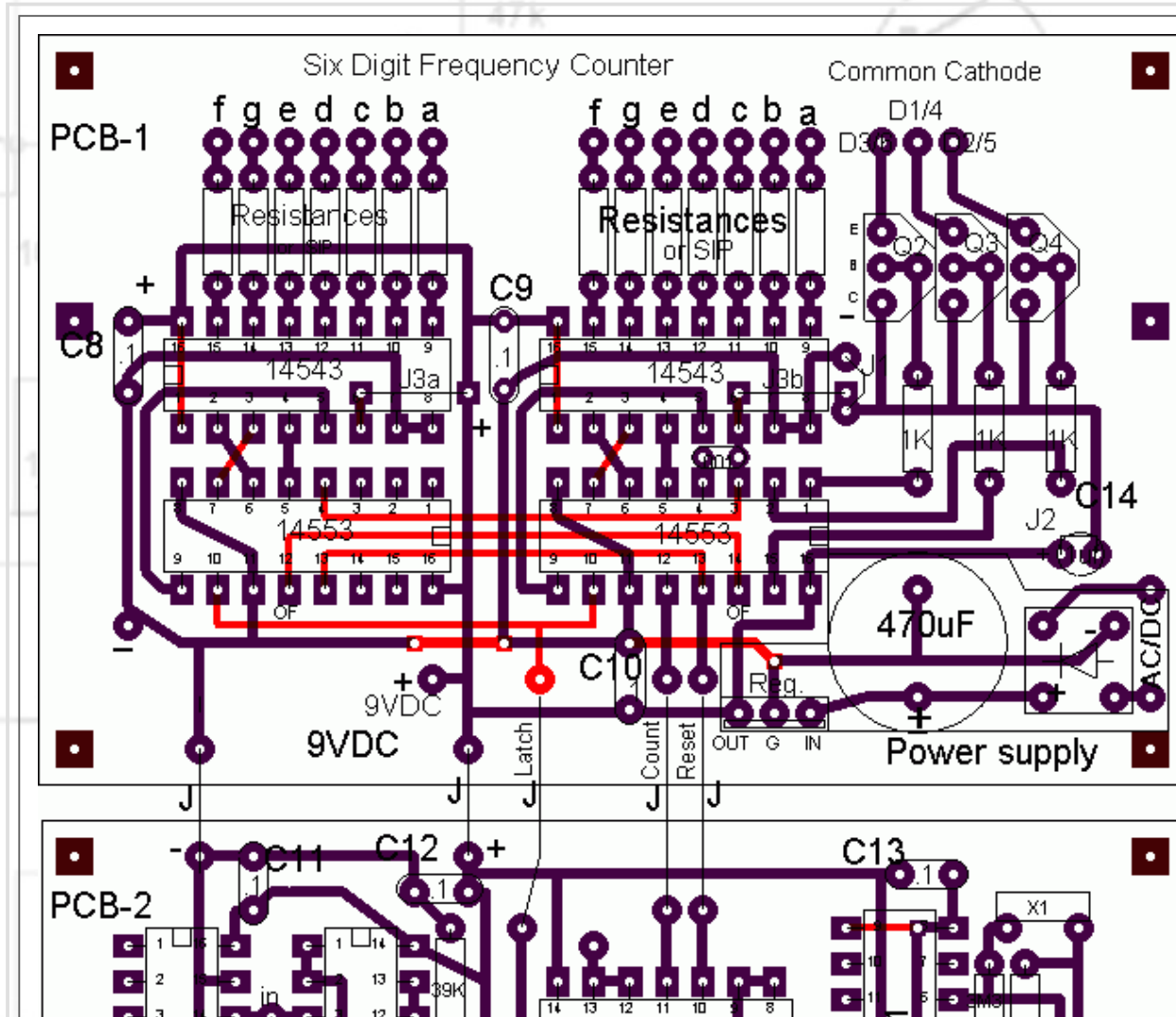

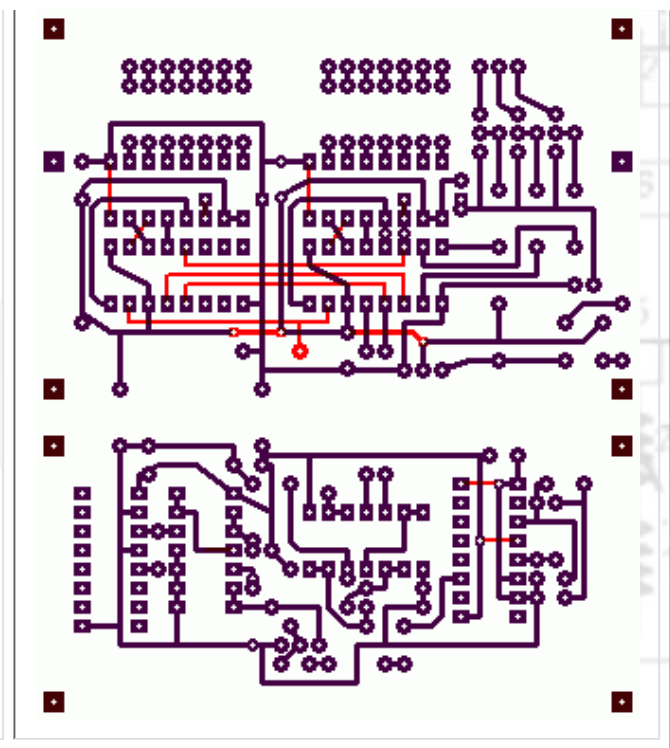
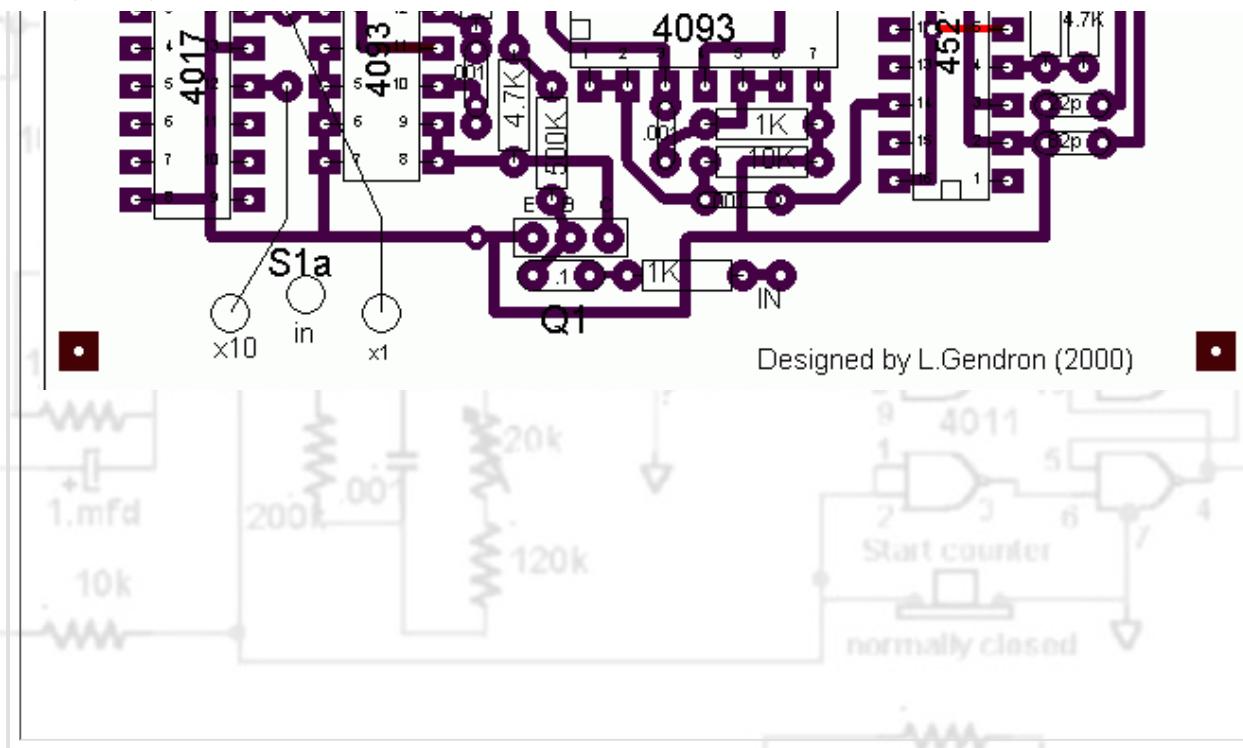

• For the experienced hobbyists point to point wiring is quite possible using No 24 and smaller gauge wire , for a single layer board it is essential that all jumpers shown in red be installed before parts and sockets are soldered into place . For jumpers under the socket I use bared wrapping wire inserted in the wholes leaving about 1/4 " of wire protruding on the solder side then fit the sockets into place then soldered all points.

Care must be taken to locate the transistors polarity for common cathode or common anode operation as explained previously . Take note that C14 is a polarized capacitor and oriented to suit the supply polarity if modified . (ref ; C14 and jumpers J1, J2 ,J3a&b)

The design will accept 14 pins Dip sockets in lieu of the 14 current limiting resistors allowing for the installation of SIP isolated resistors ICs or individual resistors with leads cut and shaped to fit the sockets for easy modification if required .

[Introduction](#) [construction-1](#) [Construction-2](#) [Construction-3](#)

[HOME](#)

6 Digit Frequency Counter

[Introduction](#)
[construction-1](#)
[Construction-2](#)
[Construction-3](#)

Power Supply .

- Because of the low current requirement of most my designs, I usually prefer 9 volts as a convenient voltage supply source and for that reason the frequency counter has also been peaked for that voltage .

Below is the schematic for the power supply used as bench instrument and the parts list required . For stability and precision it is important that the power source be regulated and I have used a 9 volts regulator for a 12 volts power transformer source . The system will work well with a higher voltage supply with the following considerations ;

- The supply voltage must be at least 2 volts higher than the regulator voltage when under full load .
- The current limiting resistors value of R9 to R22 must be increased to limit the segments LED current within the 10 mA range .
- A battery pack can be used but again a regulator should be used so that the system does not suffer degradation due to battery voltage drop . A battery voltage monitor as described in the Digital Capacitance Meter project can used to monitor the battery voltage drop and set to about 1.5 volts above the regulator voltage as an indicator of low battery voltage .
- As an option a wall transformer module can be used . Most wall transformer units are NOT well filtered and care must be taken to identify the voltage polarity of the output connection plug . Whether you use an AC or DC wall unit it is strongly recommended that the portion for the power supply circuit after the transformer , that is from the rectifier bridge and after be used to insure of the right voltage polarity and filtering .

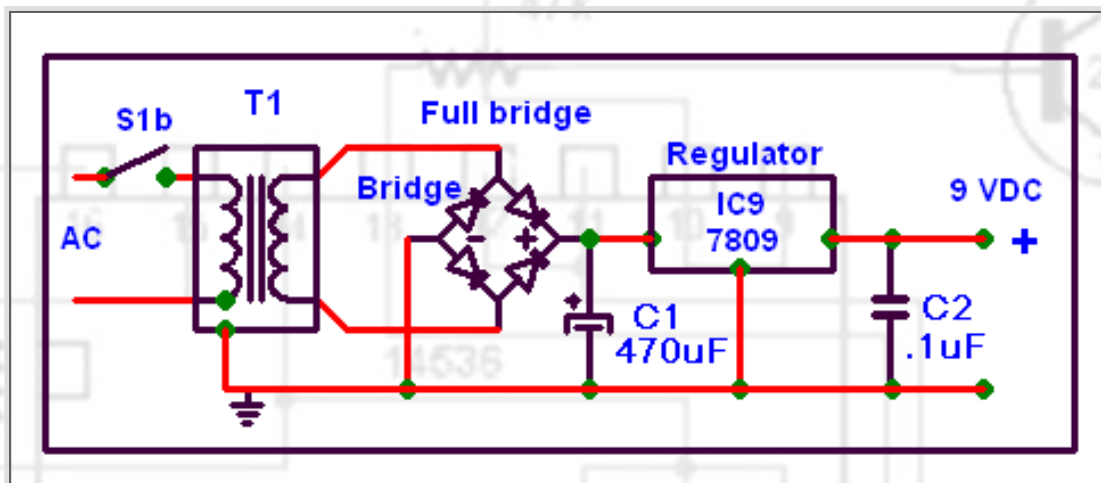

Power Supply Parts List

Power supply parts list

Transformer = secondary 12 V or 15 VAC @ 250MA
 Rectifier bridge 50V/1A
 C1 = 470uF/25V
 C2 = 0.1 uF /16V
 Regulator = 7809 (9V) or 7812 (12V) TO220 /1.5 A
 Optional , D1 - D4 = Rectifier diodes 1N4002
 Heatsink for regulator
 Line cord , enclosure , insulating grommet

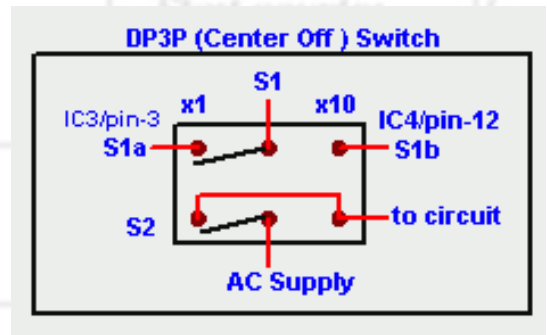

Suggestions

- Select an enclosure large enough to accommodate the circuit and the transformer . I had a spare plastic box the size of which was perfect measuring 5"W x 3"H x 6"L . I obtained the transformer from an old digital alarm clock from Sally Ann , the older the better as they all have a small 18 to 24 volts center tap transformer at about 300 mA .

A box with a plastic face panel is best as it is easy to cut a window to accommodate the six digit read-out covered with a thin red plastic as a filter as seen on my finished project , only the switch and two input plugs remain to be installed as shown . I used dry lettering transfers for the text covered with a light sprayed coat of clear lacker to protect the lettering from erasure .

Other than the switch ON/OFF with range selection there is no calibration required . A first check can be made by using a low voltage transformer with the primary connected to the AC line and measuring the 60Hz output on the low range of the Frequency Counter.

- I almost forgot to mention the and LED is used as a power on indicator , as shown on the schematic a 1K resistor is used in series and connected from the positive bus to ground . (not included on the parts list)



An RPM Meter

- From the basic Frequency Counter project presented , George Vasiliou of Greece has developed a precise RPM counter using a magnetic sensor to detect teeth on a wheel and a formula to calculate and calibrate for any size wheel/RPM . For any additional information George can be reached at "basiliou@freemail.ge "

To view the RPM project download the two following PDF's :[PDF-1](#)[PDF-2](#)

And please do not use the output from the wall AC outlet to test your meter .

[Introduction](#) [construction-1](#) [Construction-2](#) [Construction-3](#)

